

## WAIN Connector

\*The certification icons shown on the cover only represent the certifications covered by the entire catalog.  
For the certifications of each product, please refer to the technical characteristics of the product in the catalog.

**WAIN** is not only **manufacturing**, but also **creating**!

Any questions and ideas related to industrial connectors,  
we welcome to discuss with you.

## **WAIN Heavy duty connector**

Heavy-duty connector is designed for modular production pre-wiring and satisfying severe environmental conditions, which is mainly applied in rail transit, industrial automation and equipment manufacturing fields.

Compared with traditional wiring methods, use of heavy-duty connector can reduce site wiring operation after equipment or vehicle leaves the workshop, enhance production efficiency and reduce quality risk of site wiring.

Flexible production is core reflection of Industrial 4.0 modular design, production and application of all functional modules of equipment can lay solid foundation for flexible production. With deep development of industrial automation, equipment has witnessed more renovation. For example, a large amount of equipment has adopted module design whose functions have been constantly increased according to application demand.

Use of heavy-duty connectors including pneumatic modules, large current modules, electromagnetic shielding modules and D-Sub modules has not only achieved accessible and rapid connection among module equipment, but also has guaranteed transmission of signal and power supply. As for manufacturers of machinery equipment, they can not only obtain safe and reliable connection, but also save installation time and reduce comprehensive production costs. As for end users, they can easily install operation equipment without instructions of any professional personnel, and maintenance also becomes easier. It can not only increase effectiveness and practicality of machinery equipment, but also reduce installation time and reduced equipment repair time.

WAIN is a comprehensive professional enterprise with integration of R&D, manufacture and sales of heavy-duty connectors. The company has modernized work places including injection molding workshop, hardware workshop, casting workshop, electroplating workshop, assembly and mould workshop. In addition, the company has product R&D and product performance testing laboratory and several technical patents. We are dedicated to providing high-quality product for industrial connection system. WAIN connector product has thousands of portfolios and can satisfy electric and signal connection requirements of different fields and different situations.



## Contents

### Rectangular connector -Inserts

	Rated voltage	Rated current	Number of contacts	Wire Connection	Page
HA Series-the slim inserts	230/400V 250V	10A 16A	3, 4, 10, 16, 32	Crimp / Screw Spring	P01-01 ~ P01-07
HE Series-compact inserts	500V	16A	6, 10, 16, 24, 32, 48	Crimp / Screw/ Spring	P02-01 ~ P02-10
HVE Series-high voltage inserts	830V 400/690V	16A 16A	3, 6, 10, 12, 20, 16, 32	Screw Crimp	P03-01 ~ P03-12
HVES Series-high voltage inserts	830V	16A	3, 6, 10, 12, 20	Spring	P04-01 ~ P04-08
HEE Series-high density inserts	500V *690V,1000V	16A	10, 18, 32, 46, 40, 64, 92	Crimp	P05-01 ~ P05-12
HEEE Series-high density inserts	400V	16A	32, 72	Crimp	P05E-01 ~ P05E-04
HD&HDD Series -ultra-high density inserts	-120V/~50V 250V *400V, 500V	10A 10A	8 7-216	Crimp	P06-01 ~ P06-25
HSB Series-high heavy- currentinserts	400/690V	35A	6, 12	Screw	P07-01 ~ P07-07
HK Series-combination inserts	160-830V	10A-100A	4,4+2,4+4,4+8,6+6,6+12, 6+36,8,8+24,12+2,12+0,	Crimp Screw	P08-01 ~ P08-29
HE AV Series -extendible inserts HD AV Series -extendible inserts	500V 250V	16A 10A	6, 10, 16, 24 40, 64	Screw Screw	P09-01 ~ P09-07 P09-08 ~ P09-14
HM Series -flexible and combined inserts	50-5000V Fiber Optic / Pneumatic	5A-200A	1-42	Crimp / Screw Spring	P10-01 ~ P10-71
HQ Series-compact inserts	230-690V	10A, 16A, 40A	2-17	Crimp / Screw	P11-01 ~ P11-20
HC Series -high heavy-current inserts	1150-4000V	200A-1000A	1-4	Crimp Screw	P12-01 ~ P12-28
HCM Series -small sized solder insert	50V	5A	15, 18, 21	Crimp Solder	P12H-01 ~ P12H-05.1

### Rectangular connector-Crimp contacts

Type	Page
5A, 10A, 16A, 40A, 70A, 100A, 200A, 250A, 300A, 350A, 650A Crimp	P13-01~P13-07

### Rectangular connector-Accessories

Type	Page
PCB-adapter	P14-02~P14-11
Rail bracket	P14-12~P14-13
Ground terminal/Docking frame	P14-14~P14-16
Code pin	P14-17~P14-18
Cable clamp	P14-19
D-Sub adapter	P14-20

### Rectangular connector-Hoods/Housings

Size	Type	Page
3A	Hoods/Housings (Plastic, Metal, EMC, Corrosion resistance, H version Pressure tight)	P15-06 ~ P15-16.1
10A	Hoods/Housings(Plastic, Metal)	P15-17 ~ P15-18.1
16A	Metal Hoods/Housings	P15-19 ~ P15-20
32A	Metal Hoods/Housings	P15-21 ~ P15-24
6B	Hoods/Housings (Plastic, Metal, Corrosion resistance, EMC, W version, H version, C version Pressure tight, WV/HV)	P15-25 ~ P15-38.2
10B	Hoods/Housings (Plastic, Metal, Corrosion resistance, EMC, W version, H version, C version Pressure tight, WV/HV)	P15-39 ~ P15-69
16B	Hoods/Housings (Plastic, Metal, Corrosion resistance, EMC, W version, H version, C version Pressure tight, WV/HV)	P15-70 ~ P15-107.1
24B	Hoods/Housings (Plastic, Metal, Corrosion resistance, EMC, W version, H version, C version Pressure tight, WV/HV)	P15-108 ~ P15-150
32B	Hoods/Housings (Metal, WV/HV)	P15-151 ~ P15-159
48B	Hoods/Housings (Metal, WV/HV)	P15-160 ~ P15-162
HC	Hoods/Housings (Plastic, Metal)	P15-163 ~ P15-168
Thickned seal part	(H series BK housing)	P15-169 ~ P15-170

### PCB Connector

Type	Rated voltage	Rated current	Number of contacts	Terminal	Page
	1.5V	6A	48	Crimp, Solder	P15F-01 ~ P15F-06

\*By adjusting the layout of contacts, they could be applied up to 690V or 1000V.  
By adjusting the layout of contacts, they could be applied up to 400V or 500V.

To users: Part of the data pictures in this product manual may be updated. Please refer to the latest data provided by the technical department of our company while selecting the model. For the details, please call 400-882-5885, confirm with the sales personnel of our company or inquire via [info@wainconnector.com](mailto:info@wainconnector.com).

## Contents

### Rail transportation industry EC series

Type	Rated voltage	Rated current	Number of contacts	Terminal	Page
★	2000V	650A	3	crimp terminal	P15E-02 ~ P15E-08

### High temperature series

Type	Rated voltage	Rated current	Number of contacts	Terminal	Page
★	16V	500A	6,10,16,24+PE	screw clamp connection	P15H-01 ~ P15H-08

### Circular connector

	Rated voltage	Rated current	Number of contacts	Terminal	Page
Technical characteristics					P16-02 ~ P16-10
M8	30V,60V	4A	3,4,5	screw clamp connection, solder,dip solder, moulded	P17-01 ~ P17-22
M12-A	60V, 125V, 250V	2A, 4A, 8A	3,4,5,8,12	screw clamp connection, solder,dip solder, moulded,single wires	P18-01 ~ P18-41
M12-B	125V, 250V	4A, 8A	2,3,4,5	screw clamp connection, solder,dip solder, moulded,single wires	P18B-01 ~ P18B-28
M12-D	250V	4A	4	screw clamp connection, solder,dip solder, moulded,single wires	P19-01 ~ P19-16
M12-S	630V	16A, 12A	3, 4	crimp terminal	P19S-01 ~ P19S-16
M12-L ★	63V	16A	5(4+PE)	screw clamp connection, solder,dip solder, moulded,single wires	P19L-01 ~ P19L-10
M12-X	250V	4A	8	crimp terminal,single wires	P19X-01 ~ P19X-08
IO-LINK Sensor junction box ★	-	-	-	-	P19K-01 ~ P19K-06
M8/M12 Distributor M8/M12 Sensor junction box	60/250V 10~30V DC	4A 2A, 9A	4,5 4,5	- pluggable M23	P20-01 ~ P20-05
7/8	300V	8A, 9A, 10A, 12A	3(2+PE),4(3+PE),5(4+PE)	screw clamp connection,	P21-01 ~ P21-08
M15 ★	63V	5A	12	crimp terminal	P21Q-01 ~ P21Q-08
M17	32V, 60V, 630V	3.6A, 7A, 14A	7,12,17	crimp terminal	P21S-01 ~ P21S-11
HR23(M23)	25V~/60V-	7A, 15A	6,9,12,17,19	crimp terminal, (PCB)solder terminal screw clamp connection	P22-01 ~ P22-14
MR23	25V~/60V-	7A	12,17	crimp terminal	P23-01 ~ P23-07
M23	250V, 630V	9A, 30A	6,8	crimp terminal	P24-01~ P24-17
M40	250V	20A, 60A	4/4	crimp terminal	P25-01~ P25-05
Q38	250V	13A, 30A	12+19, 32 (28+4), 48	Quick connect card slot	P25Q-01~ P25Q-06
Power electrical connector	220V, 250V	1A, 13A, 20A, 25A, 40A	4,5,6,10,26,RJ45&3	crimp terminal, solder terminal	P26-01~ P26-08
Customized product-HW	1000V	800A	1	crimp terminal	P27-01~ P27-04
Customized product-MI	400/30V	6/1A	6+6(5+PE)	crimp terminal	P27-05~ P27-06

### Personalized product

	Rated voltage	Rated current	Number of contacts	Terminal	Page
HCC Series-single row inserts	500V	30A	10	Screw terminal	P28-01 ~ P28-02
HV Series-single row inserts	400V	20A	8	Screw terminal	P29-01 ~ P29-04
The State Grid Anti-Open Connector	500V/250V	40A, 10A	24+8 (anti-open circuit) +1 (grounding) 8+8 (anti-open circuit)+40 6+PE	crimp terminal, (PCB)solder terminal screw clamp connection	P29-05 ~ P29-08.8.1
D-Sub-044 Series		3A	44	crimp terminal	P29-09 ~ P29-12
Charging socket / Test Tool (TL-DZ)	500V/12V	150A, 2A	8/2	crimp terminal	P29-13 ~ P29-18
IO / WP Series	100V (IO)	0.5A(IO)	18(IO)		P29-19 ~ P29-22
wiring harness					P30-01 ~ P30-14
Optical fiber					P31-01 ~ P31-04

### Tools/Cable gland

	Page
Tools/Cable gland	P32-01 ~ P32-27
List of part no.	P33-01 ~ P33-33

## Certification

### System certificates



ISO 14001 Certification



ISO 9001 EN(TUV)Certification



ISO 9001 中文 (TUV)Certification



IRIS Certification

### Product certificates



VDE Certification



UL Certification



CE Certification



CQC Certification



EAC Certification

**Introduction to IRIS:** IRIS, standing for International Railway Industry Standard, is an initiative led by the Union of the European Railway Industries (UNIFE). It is mainly used to ensure the high quality of the whole railway industry and make the manufacturers of railway equipment meet the requirements of global railways for high-quality railway parts and increase their competitiveness in the world. IRIS aims to develop and implement a universal system to evaluate the quality management systems of railway industry. IRIS adds railway specific requirements into ISO 9001; in short, IRIS is the extension of ISO 9001 for railway industry.

**EUROMAP** WAIN is one of the recommended suppliers of EUROMAP, the Europe's Association for plastics and rubber machinery manufacturers.

#### EUROMAP recommendations:

The inserts and the relevant enclosures meet the EUROMAP Recommendations (European Committee of machinery manufacturers for the plastic and rubber industry) EUROMAP 12, 13, 14.1, 14.2, 16, 27.1, 28, 29, 62, 67, 67.1, 70, 73, 74, 78

For more information, please visit WAIN's homepage: [www.wainconnector.com](http://www.wainconnector.com)

## WAIN "WU" single module connector series

The innovative products of WAIN in 2016 combine dozens of modules (large current, signal current, optical fiber, gas, Ethernet and so on) into an independent unit with EMC performance and a protection level of IP65.

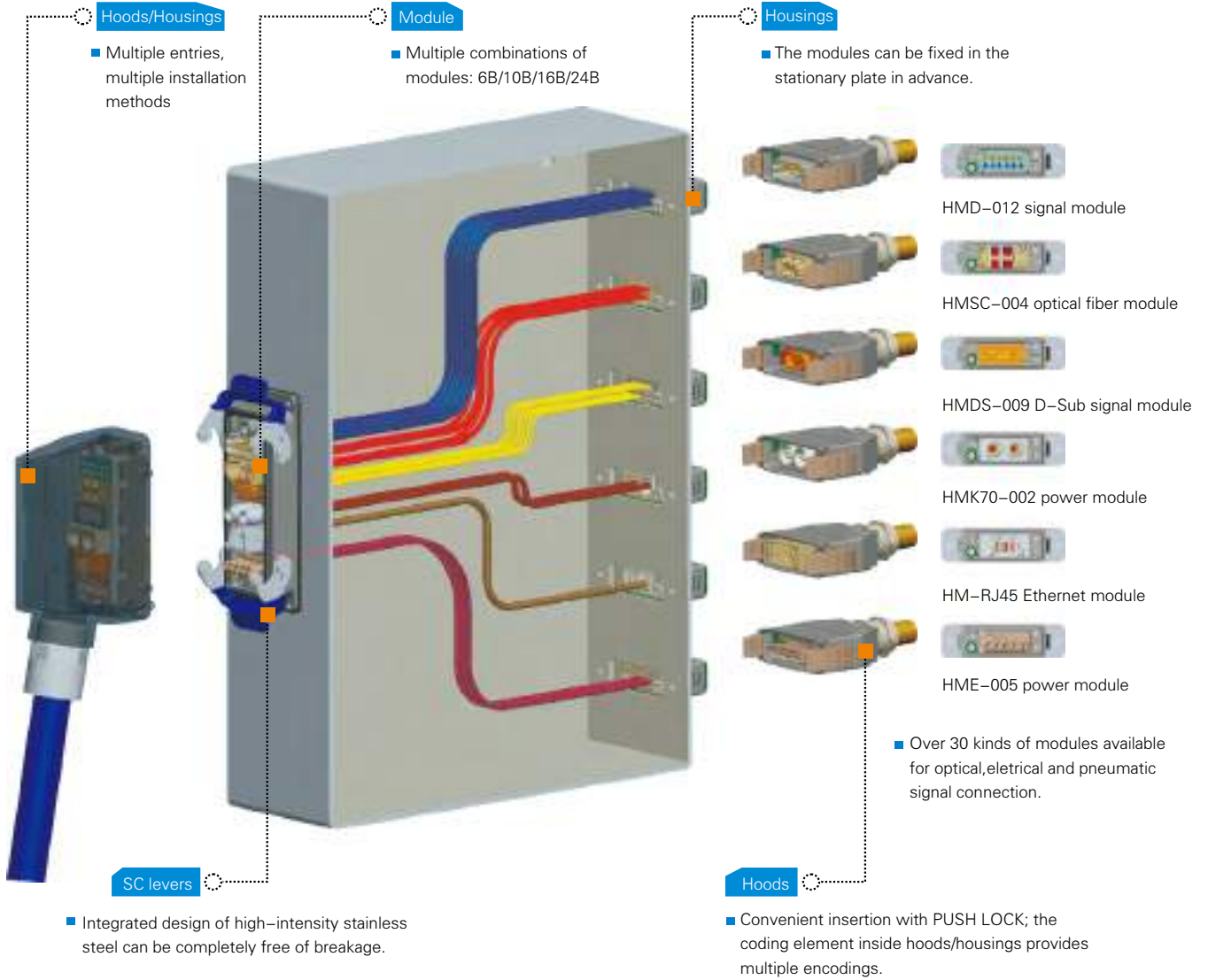

WAIN provides solutions for various branching integration demands!

### Characteristics

- smaller width, more compact, space-saving;
- convenient locks save time during assembly;
- encoder inside hoods/housings provides multiple encodings;
- modules can be fixed in the stationary plate in advance;
- With grounding function;
- Grounding screw is in vertical direction, which does not interfere with the face plate so that operation space is large;
- It is matched with multiple single module slugs;
- EMC function;

For more information about the hoods, housings and modules of "WU" Series, please refer to HM Series.



## WAIN joins the EPLAN Data Portal

We are glad to inform you that WAIN products are now available in the EPLAN Data Portal. There are more than 3500 components online for your reference. In this way, customers can select WAIN products more quickly and conveniently so as to save the time of design and production, furthermore, improve efficiency.



- WAIN has more than **26578**<sup>[1]</sup> products, which are applicable in most of the industrial application scenarios!
- Wain offers also customization service for industrial connectors!

[1] Data sourced from WAIN-ERP System, statistics time: 2023.07.01.



## WAIN new hoods/housings (IP67)

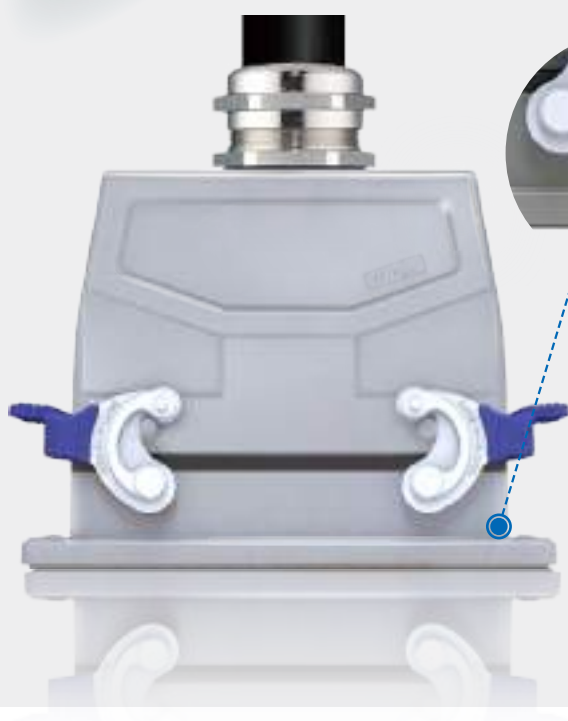

### ■ Glue-free bottom base

Hidden base pad, better corrosion resistance!

### Characteristics

- New appearance by independent development.
- Degree of protection IP67.
- The hidden glue-free bottom base provides better corrosion resistance.
- Compatible with the old-designed hoods/housings.

## WAIN metal docking frame

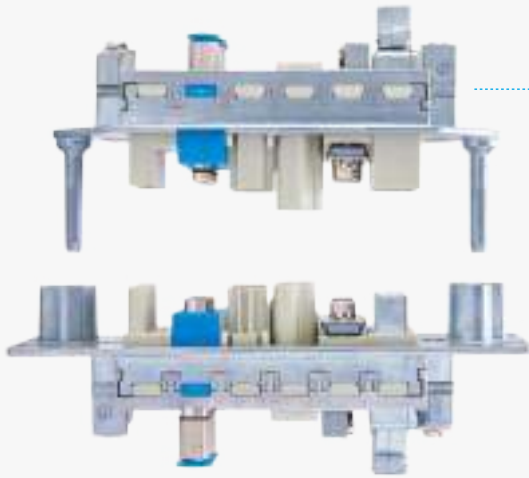

Direct installation without hood and housing

### Characteristics

- Easy assembly and disassembly with hanging type half-threaded screws.
- Putting guiding pins into conical holes to realize guiding.
- Using the floating washers to increase gaps, it helps to increase guiding function.
- Guiding through crown spring improves the safety performance greatly.
- Direct installation and no need to match with hoods/housings.

## WAIN metal pneumatic module



### Characteristics

- Easy assembly and disassembly of contacts and modules by using contact removal tools.
- Quick connection and disconnection of the air tube.
- Metal pneumatic contact increases strength and service life of the module.

## WAIN MR23 circular connector

- Efficient mounting and removal of contacts through Push-Pull mounting technology



### Characteristics

- Crimp connection stabilizes the signal transmission in vibration environment.
- Push-Pull mounting technology realizes efficient mounting and removal without any tool.
- Reverse coding is also available.

## WAIN extra large plastic hood



- Largest wire diameter of  $\Phi 47\text{mm}$



### Characteristics

- The hood is designed as a separate structure, easy assembly and disassembly with screws
- Enlarged space inside the hood makes it convenient to connect and install large cables
- Mating hood and housing with locking levers, the connector will not easily fall apart
- Excellent electrical insulating property (Insulating resistance  $> 10^{10} \Omega$ )
- High performance material suits the harsh environment
- Light weight, high mechanical properties and economical
- Widely used in various applications, compatible with regular inserts, frames, etc.

## WAIN 32 pin anti-open circuit connector



Assembly and welding of two-stage welding pins  
The stress relief structure of PCB electrical connection can release the stress, so as to protect PCB from damage.



### Characteristics

- The stress relief structure of PCB electrical connection can release the stress, so as to protect PCB from damage.
- Assembly and welding of two-stage welding pins: one or more pins and PCB at male end welded with female plug at the same time; better protection of welding points; more effective and reliable operation of the system; easy installation and maintainance.

## WAIN modular type plastic hoods/housings



- Snap-in type, easy to operate.

- Compared with metal frame, there is one more module space.



### Characteristics

- The hoods and housings are connected by special latch design, which prevents from falling off.
- High performance materials are adapted to harsh environment.
- Light weight, high mechanical strength and low costs.

## WAIN 7/8 Circular connector

- Screw terminal, Easy assembly on site.



### Characteristics

- Original anti-loosing joint to avoid accidental loosening, with superior performance in shock resistance and vibration load.
- 7/8 flange seat with fixed cable wiring design, greatly improving cable life and connection stability.
- Screw terminal, easy to maintain and operate! Easy assembly on site.
- Patented design with sleeve pin to improve mechanical life.
- Superior waterproof, dustproof and explosion-proof performance, with protection grade up to IP67.
- The connector is made of high temperature resistant material, with the maximum temperature of 125 °C, and the fire rating of UL94V0

## WAIN enlarge metal hood

- Internal space up to 63mm wide  
Large cable, easier wiring and installation!

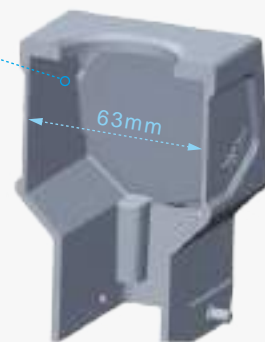

### Characteristics

- The internal space of the conventional 24B high structure hood is only 34mm, and the internal space of this extra large shell can reach 63mm.
- Increase the internal space to ensure that the cable with large cable outer diameter can also be wired.
- It is made of aluminum alloy metal with high strength and long service life!
- It can be compatible with conventional insert, frame and other usage, and has a wide range of uses.
- Wiring methods: side entry/top entry.

## WAIN new and upgraded modules



The max is up to 2.5mm<sup>2</sup> terminal connection

Open cover up and down.  
Simple insertion in the corresponding insert hole position when installing.  
Easy operation.

Limiting stopper buckle, design of the cover against falling off.

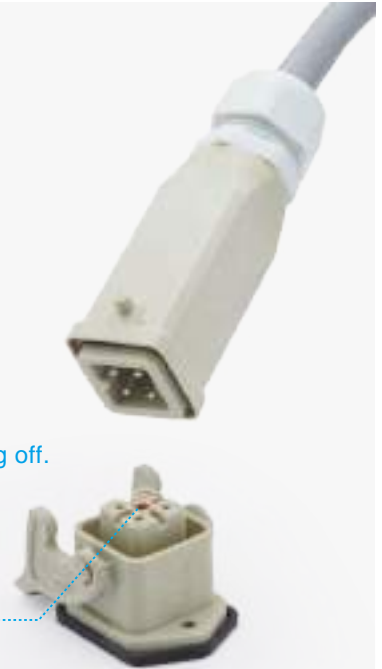

Function of coding pin.

### Characteristics

- There is a cover barrier between the insert and shell, which ensures sufficient creepage distance and reliable electrical performance.
- The top outlet avoids folding the wire to 90° then upwards, as by side outlet. The operation is convenient by wiring.
- The protective cover has a reliable structure. The cover will not fall off when pushed up and down.
- It has the function of coding pin, including 4 encoding modes.

## WAIN M12 circular connector, L-coded



Accommodates up to 14AWG wire,  
with options for crimp or screw terminals

### Characteristics

- Installable series and moulded cable series
- Thread locking M12X1
- Shielding ring and ring spring shielding connection
- Cable length 1.5m and 5m
- Other cable length upon request, minimum order quantity 200 pieces
- Cable material can be customized according to requirements
- Degree of protection IP67/ IP68
- Transparent case for PCB with LED

## WAIN M12 circular connector,X-coded



### Characteristics

- High data transmission speed, up to 10Gbps.
- Full metal shell, effectively anti-electromagnetic interference.
- Cold-pressed contacts, effectively anti-vibration and highly data transmission stabilizing.
- Fixition of contacts into inserts by side press, easy assembly and maintainance without tools.

## WAIN 1440 shell

The neutral salt spray test  
is up to **1440** hours  
(C5H grade)



### 1440 Shell

- Adopting the special treatment process.
- The neutral salt spray test is up to 1440 hours (C5H grade).
- Applicable to all the aluminum alloy shell.
- Applicable in the environment with high anti-corrosion requirements.

## WAIN independently developed "TL-DZ Contact retention test tool"

The indicator



**WAIN TL-DZ Contact retention test tool** is a kind of tool for detecting contact retention, using the LED indicator function to visualise the test results. The tool is compact and simple to operate, chrome-plated and fine in appearance. It has a mechanical life of over 100,000 times, a variety of free replaceable heads and is compatible with various contact detection, whose detection strength is customizable!

\*Please refer to P31-05~P31-06 for selection and operation.

① Female head:

used for the detection of 16A female contact (optional)

② Female head:

used for the detection of 10A female contact (standard)

③ Female head:

used for the detection of 5A female contact (standard)

④ male head:

used for the detection of 5A/10A/16A male contact detection (standard)

## WAIN M15 circular connector

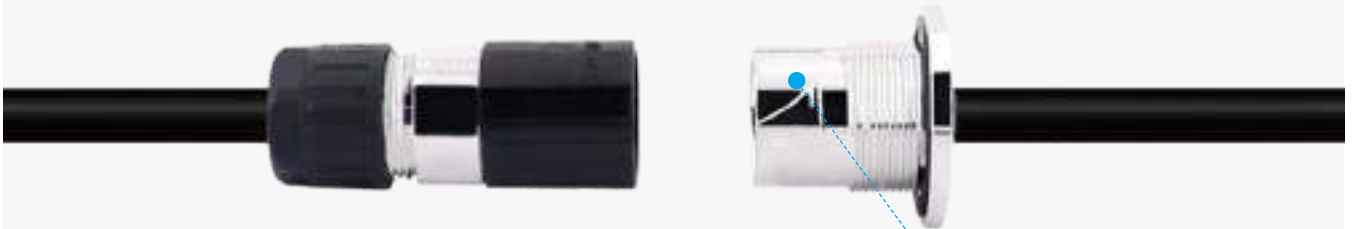

● Direct Plug Quick-Connect

### Characteristics

- Features a quick-connect structure for straightforward and convenient installation.
- Full metal shell, effectively anti-electromagnetic interference.
- Cold-pressed contacts, effectively anti-vibration and highly data transmission stabilizing.
- Fixition of contacts into inserts by side press, easy assembly and maintainance without tools.







# WAIN IO-Link Field Bus I/O

- Supports bidirectional communication between multi-point intelligent sensors or actuators and control terminals



## ■ Characteristics



**Easy installation and wiring to reduce costs and increase efficiency**



**Quick Maintenance**  
Reduce maintenance time and downtime costs

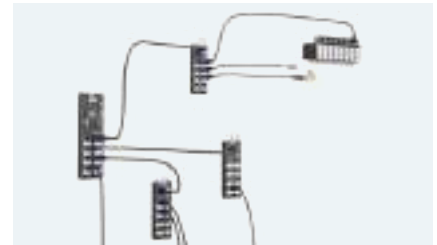

**Add more points via IO-Link hub**



**Plastic & Metal versions**  
IP67 protection degree



**Metal version is suitable for special environments**  
Anti-welding slag, anti-oil and anti-corrosion



**It can be used in industrial automation, robotics, logistics, medical equipment**

## WAIN metal docking frame with Single module



### Characteristics

- Easy assembly and disassembly with hanging type half-threaded screws.
- Putting guiding pins into conical holes to realize guiding.
- Using the floating washers to increase gaps, it helps to increase guiding function.
- Guiding through crown spring improves the safety performance greatly.
- Direct installation and no need to match with hoods/housings.

## WAIN HM-RJ45-M/F module

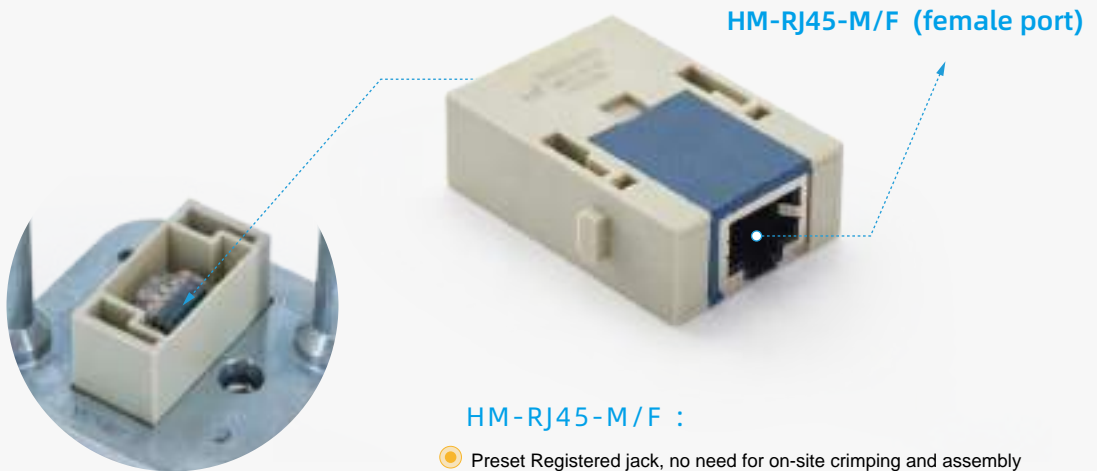

HM-RJ45-M/F (male port)

HM-RJ45-M/F (female port)

### HM-RJ45-M/F :

- Preset Registered jack, no need for on-site crimping and assembly
- The male module does not require additional adapter assembly
- Suitable for WAIN standard framework or single module framework
- Transmission features: Category 6 /Class E up to 500 MHz

Note: For single module metal frame, please refer to P10-06.1, and for HM-RJ45-M/F module, please refer to P10-49.1

# WAIN quick-in wiring technology series

**80%**

- Reduced about 80% time compared with traditional wiring.

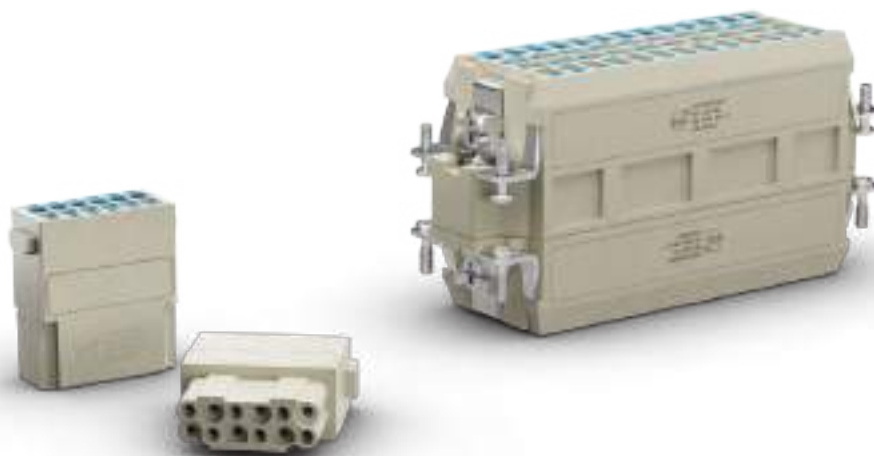

## ■ Characteristics

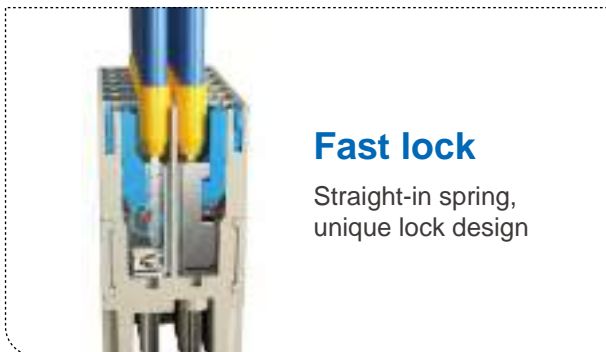

# WAIN New Spring Version Quick-in Insert



- Integrated jumping ports
- Integrated jumping ports
- Mating cycle of terminal jumper  $\geq 500$  times

## ■ Characteristics

● **Insert directly for quick-in wiring**  
Wire with the ferrule hard wire tin-soaked wire

● **Varieties of jumpers**  
Free combination

● **Vibration-proof**  
Interference point design

● **Application in hot runner injection Molding machine and other industries**

● **With test port**  
The test port diameter is 1.95mm, while the test lead has a diameter of 2.00mm.  
The slightly smaller test port reduces shaking of the test lead and increase the test stability.

# WAIN underwater connector technology



● High reliability **wet mating** underwater at **7000m**.



## ■ Characteristics



High compression resistance and corrosion resistance.  
Adoption of high-strength titanium alloy.

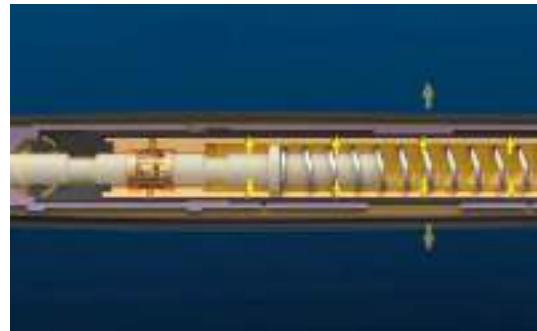

Double layer oil sealing.  
Automatic flushing and purification when mating.  
Pressure balance under deep sea.



Male and female mating self-locking function.  
Self-locking completed when unplugged.



Safe and reliable connection.

# WAIN high voltage connection system of new energy vehicle

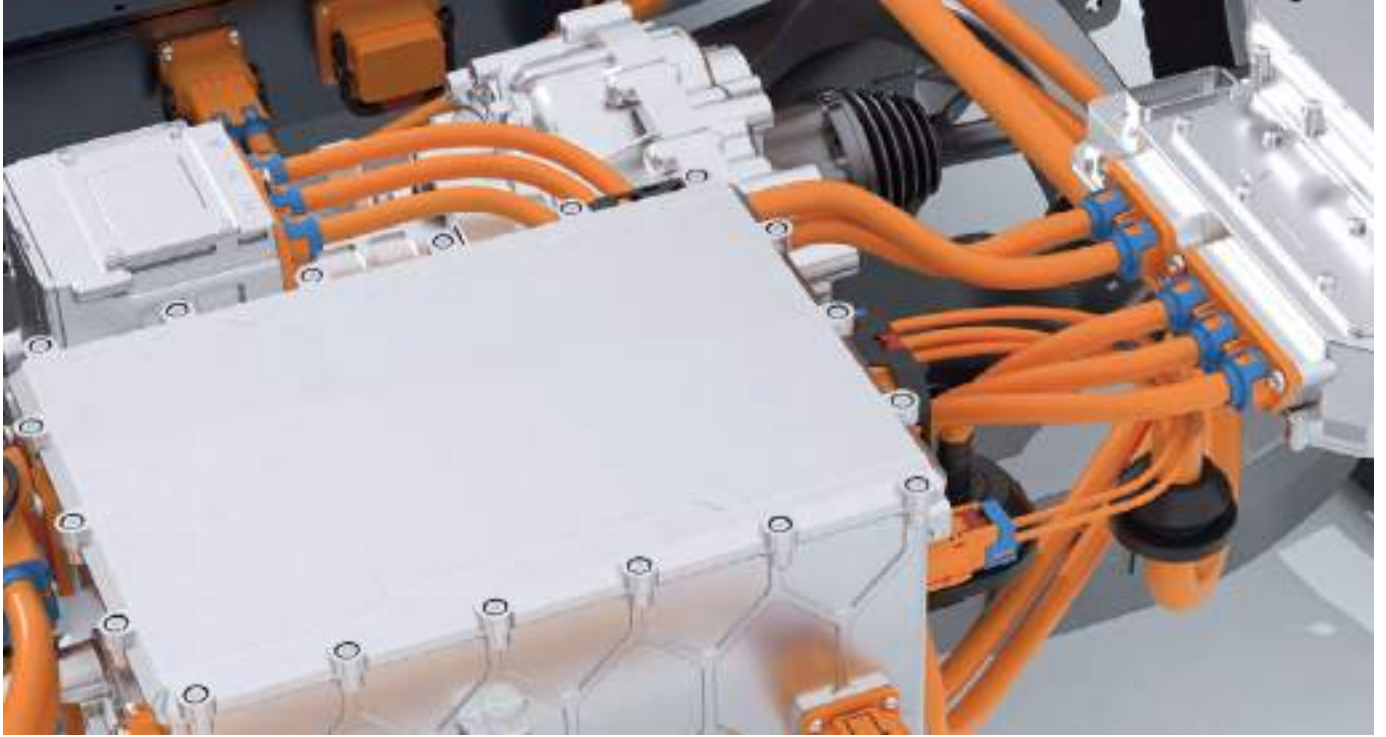

## High voltage interconnection diagram of EV

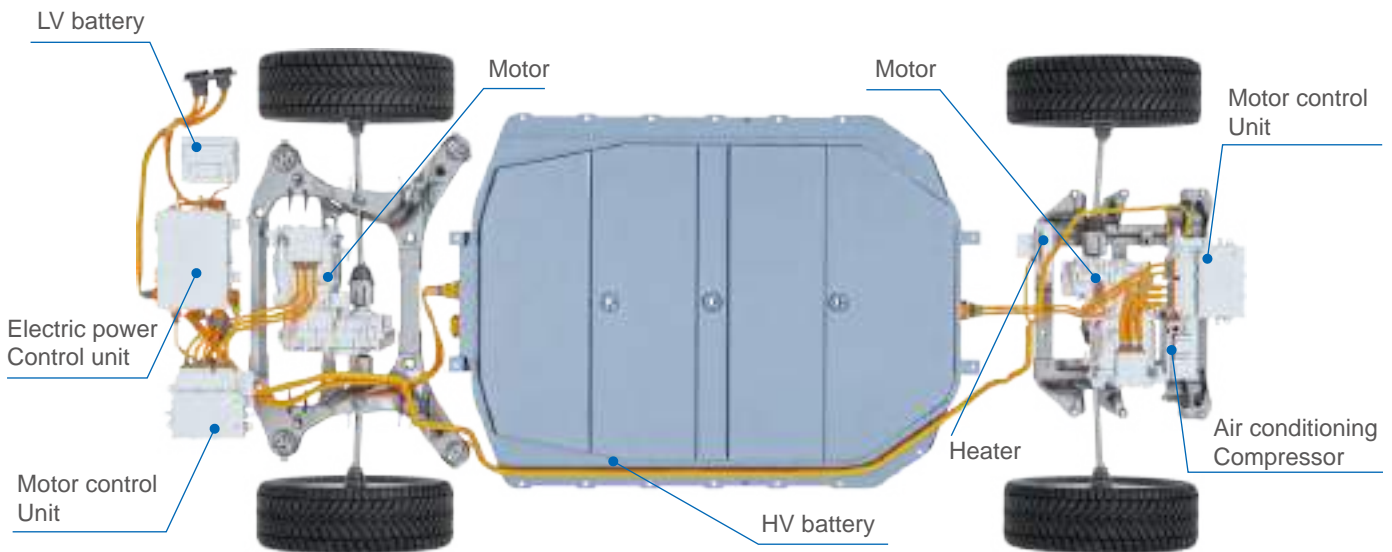

# WAIN high current connector

- Quick mating    Dafe and reliable    Patented design

Quick nut reversing device

Color coded for 3-phase identification



Rapid fastening



Contraction gap  
Prevent connector damage



Double crown spring to  
Increase contact surface



Super load-bearing tensile strength



Electric shock proof

## WAIN m12 junction box

- Compact structure, elegant appearance, convenient wiring, strong scalability.



Prefabricated cables, on-site wiring.  
Meeting the needs of different customers.



Led power and signal indicators give real-time feedback of product status.



Forming 90° angle to each other.  
Adapted to straight, bent and other connectors.



Compatible with a variety of small distributors.



## WAIN PCB connector

- Connecting PCB for signal transmission

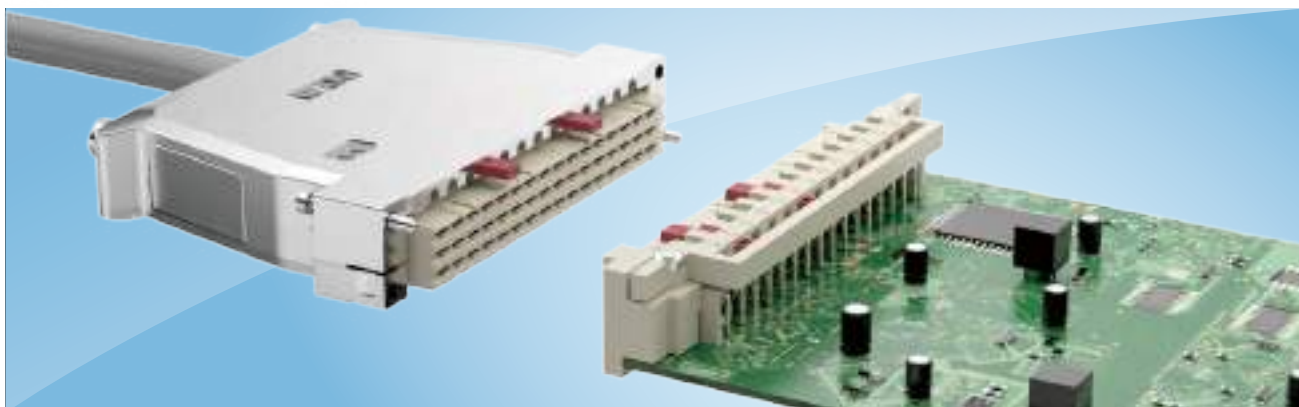

### ■ Characteristics



Full metal shell, rugged and durable

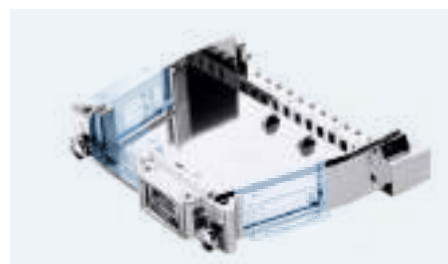

4 optional cable outlet methods



Reversible cable clamp, flexible and convenient



Supports coding fool-proof mechanism

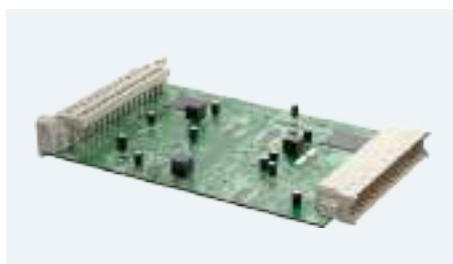

PCB welded used for signal transmission



Perfect for rail transit applications

## WAIN PCB connector

- Perfect for electric control cabinet of construction. Machinery applications and so on.



### Wire to board connector

For signal transmission



### Pcb mount relay socket

For relay pcb mounting



### Intuitive double row spring contact

Double contact surface

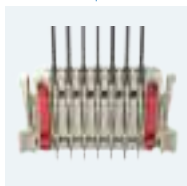

### Pin coded fool-proof



### Color coded fool-proof

Engineered for rapid connectivity between circuits



### Integrated rubber shock absorber

Preventing pcb board from crushing



### Easy to install

Reliable soldered installation

## WAIN terminal block type connector

WAIN terminal block type that extends into the cabinet can be applied to not only wiring installation in the control cabinet in the industrial industry, but also to guide rail connection. The connector is convenient for on-site operation, repair and maintenance. The wiring process is simplified by prefabricated cables, which is fast and effective.



### ■ Characteristics



#### Installation outside the cabinet

Wiring in the cabinet is convenient for on-site operation, repair and maintenance.

Non-PE side terminal first into the bulkhead mounted housing.

#### Installation inside the cabinet

Prefabricated cables, fast and effective wiring



#### Easy connection outside the cabinet

#### Extensive application

Matched with locking elements, the connector can be directly applied to the guide rail.

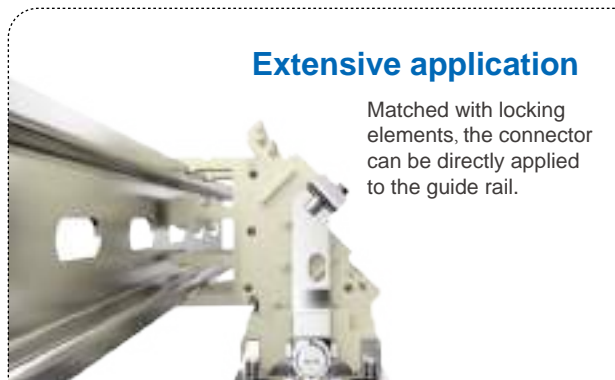

# WAIN PCB connector

- High density insert 108 pins

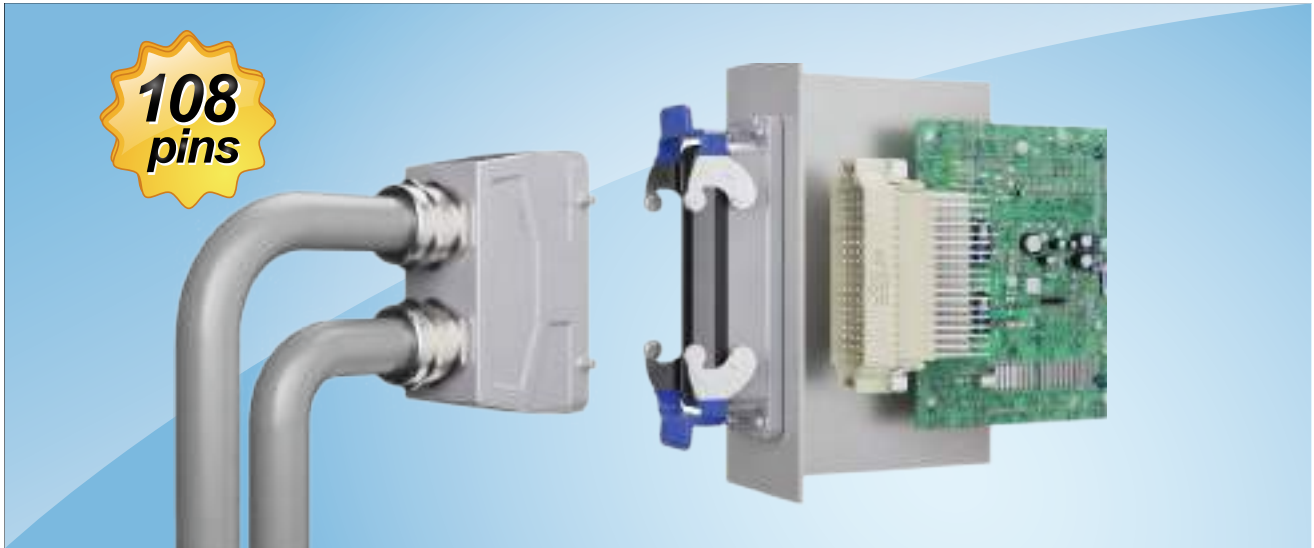

### 90° angle wire-to-board connector

Used with different PCB layout, either 90° or 180°



### Advance method

Reverse insert assembly  
 Assembly and disassembly outside the cabinet  
 Convenient installation and maintenance



### Pcb overall soldering wiring;

High assembly efficiency

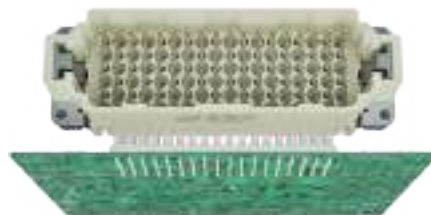

### 108 pins with fixing plate

Quick and easy insertion

## WAIN CCAB rail bracket

- Convenient assembly and flexible position change



### Technical information

Applicable rail specification (DIN BN60715: 35\*7.5 or 35\*15)

Minimum supporting force on supporting rail  $\geq 450\text{N}$

Material: PC

Flame retardant rating: V0 (according to UL94)

Operating temperature range:  $-40^{\circ}\text{C}\sim 125^{\circ}\text{C}$

Application: Inserts and modular frames of all compatible with B size shells.



**Suitable for modular frames and inserts with different specifications**



**Adjustable construction**  
**Compatible with 6B 10B 16B 24B.**



**Secure and reliable insert locking mechanism, easy disassembly.**

**Cables can be locked with cable clamps.**

**Snap-in docking mechanism, easy handling.**



**Compatible with horizontal and vertical rails, ideal for flexible field installation.**

**The protection cover protects the cables against dust deposits and unnecessary contact.**

**Easy Identification Tag.**

## WAIN LED display connector

- Providing signal and power connection

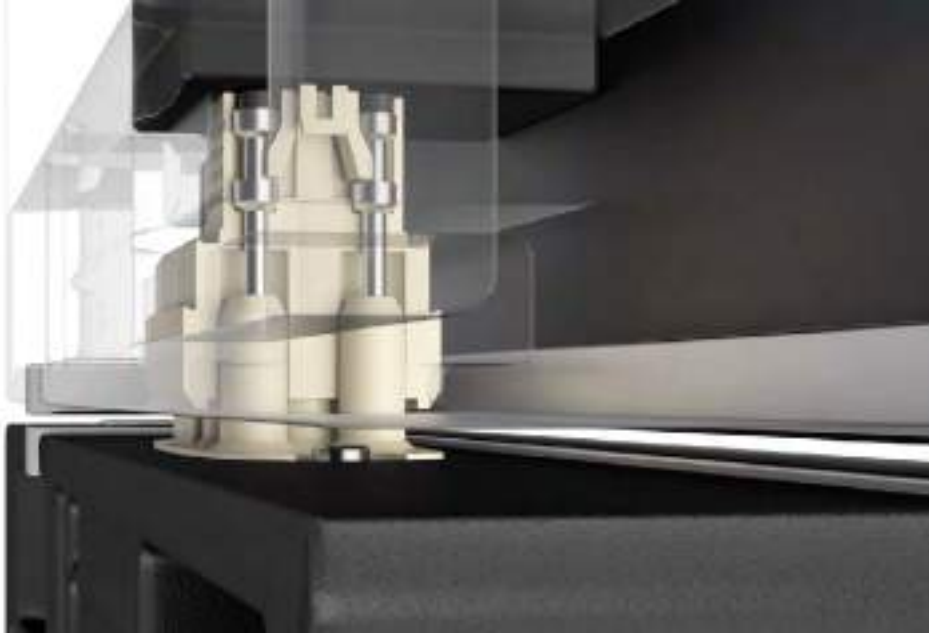

### ■ Characteristics



**With signal and power transmission**



**The screws are pre-hung and do not fall off**



**High mating and good reliability**

Suitable for standard metal shielded RJ45 crystal head



**Easy assembly and disassembly, good stability**

Metal shielding module



**Mating fast and safe**

Fool-proofing mating chamfering guide



**Floating docking**

## WAIN 24 contacts shielding module

- Small space, big satisfaction.



### Technical information

HMSB-024-MC/FC(Signal Module)

Number of contacts: 24+Shielding

Rated current: 4A

Rated voltage: 32V

### Characteristics



**Single module  
Metal EMC shielding**



**EMC electromagnetic  
shielding**



**Single module  
24 signal contacts**



**Flexible match with other  
modules**



**Innovative foolproof design**

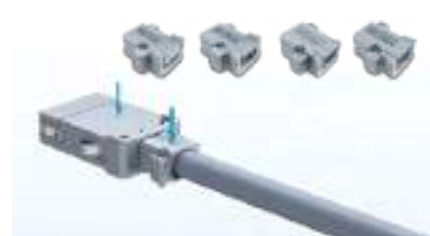

**A wide range of cable  
clamping capacity,  
a variety of wire gauge  
available.**

# WAIN coaxial module

- Designed for RF communication equipment

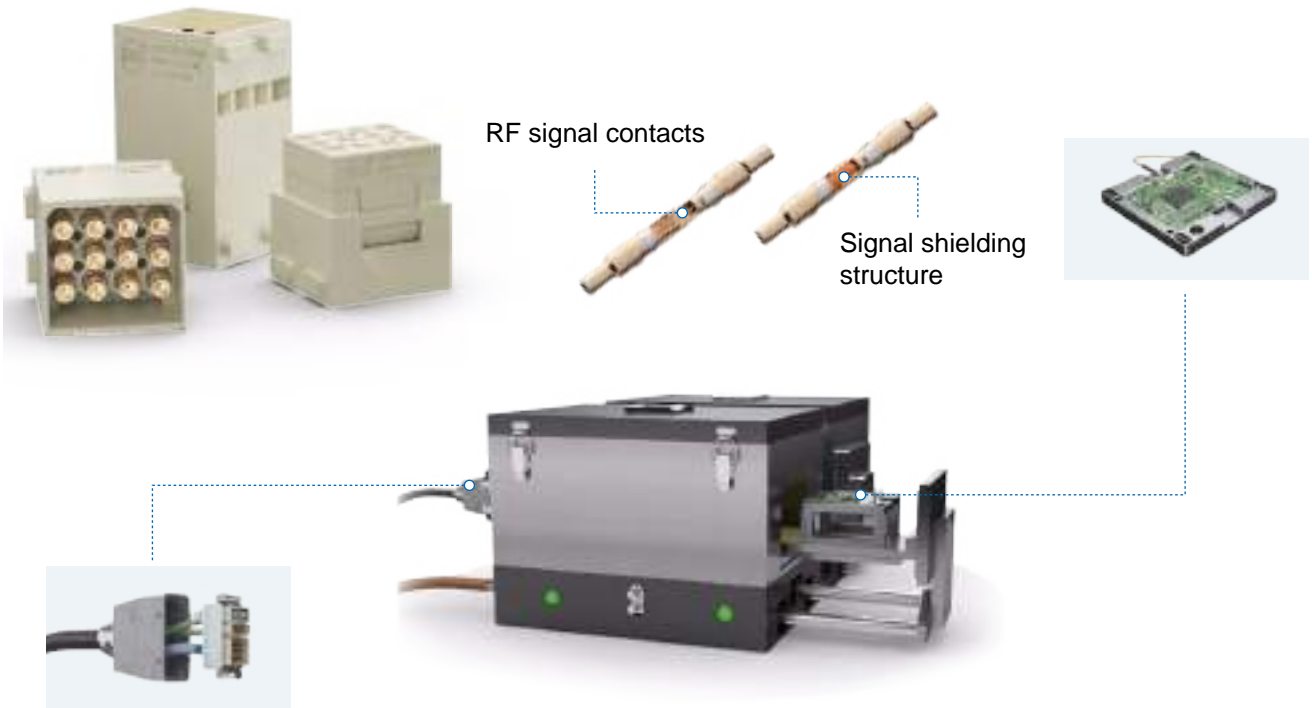

## Characteristics



For RF signal transmission



Easy assembly by pushing contacts direct from insert bottom



Foolproof design



One module supports up to 12 channels



Quick and easy disassembly with contact removal tools



Flexible combination with other modules



# WAIN modular connector

- Connecting unlimited possibilities.

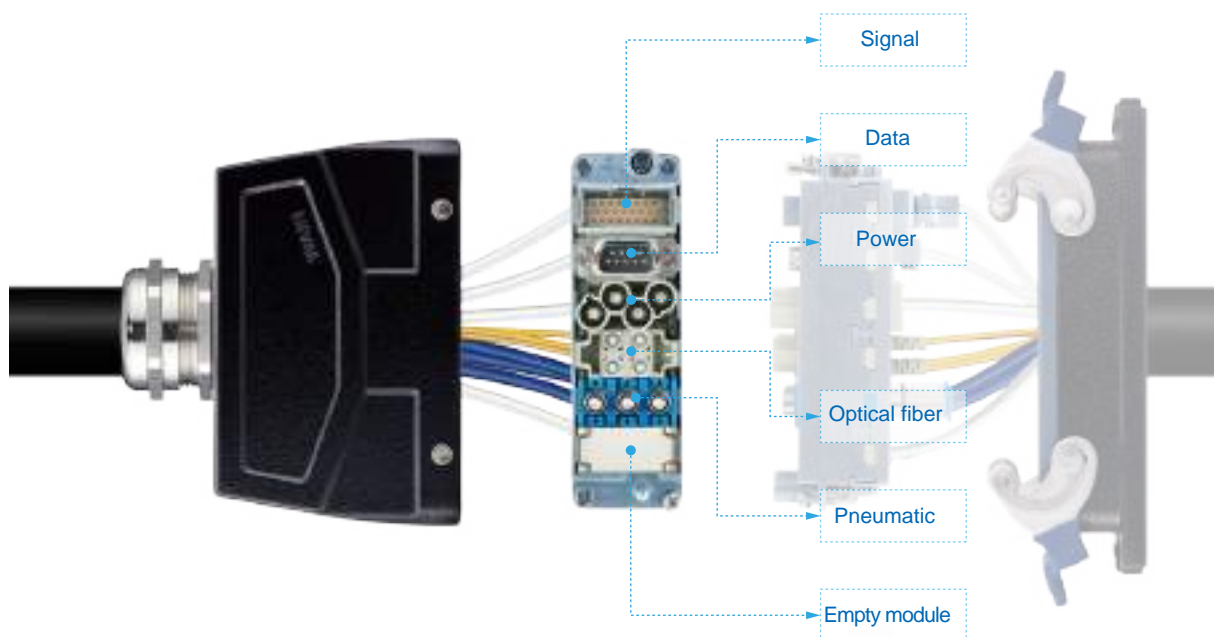

## Five advantages of wain module system

- Perfect integration of power, signal, optical fiber, and fluid connection.
- The pre-assembled cable harness is rapid, professional, reliable and timesaving.
- The standard size fulfills multi-transmission and saves space.
- Various module combination within one connector saves costs.
- Reserving dummy modules, to change in constant.



## Flexibly / High versatility



# WAIN hot mating connector with emergency disconnection function

- Protection for the data center with fuse function



## ■ Characteristics

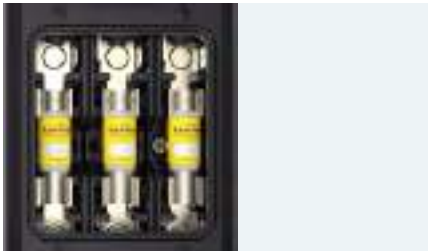

**Pre-installed fuse**



**Protection of circuits and equipment**

Instantaneous disconnection of the circuit in the situation of current overload



**Transparent shell design**

Easy observation and replacement of components



**Fuse function**

Withstanding emergency disconnection



**IP protection design**

Protection for circuits and equipments



**Data center**

Additional security protection

# WAIN data & communication modular connector

- A diverse product portfolio of communication modular connectors



## Various interfaces



**X-Code**  
Safe and reliable 10Gbps high-speed data transmission



**D-Sub**  
Transmission of analog, digital and series data



**Fiber optic module**  
For high-speed optical fiber transmission



**CAT6A**  
Bandwidth up to 500MHz, less crosstalk.



**Coaxial module**  
RF signal transmission



**Communication modules**  
Flexible combination into modular connectors

## WAIN circular connector

- Extensive range of circular connector products



Wide selection of product series, abundant variations of product structure.



Our connector portfolio includes: A Code, B Code.....

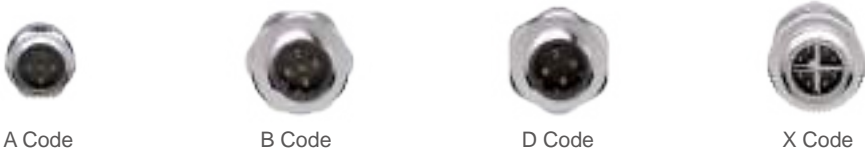

Various pins configurations available



## WAIN MI mini connector

- Small connector for power and signal in one



With the top+side wall open design. ←  
Cable can be easily perforated, convenient to install and disassemble.

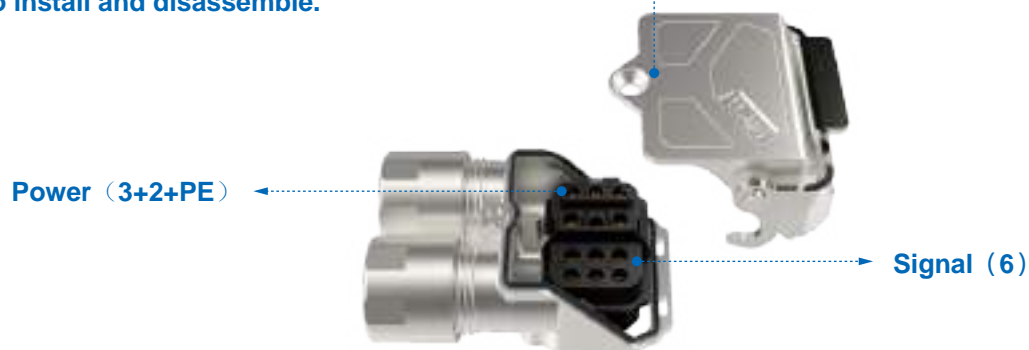

### Characteristics

- Adopt button structure to realize rapid installation and disassembly.
- Crimping structure, with the advantages of efficient crimping, earthquake resistance and convenient maintenance.
- Shell is 360 ° overall shielded, and the power and signal areas are isolated separately.
- Double cable outlet, the max diameter of cable outlet can reach  $\Phi 7.5$ .
- With the top+side wall open design. Cable can be easily perforated, convenient to install and disassemble, and greatly shorten the assembly time.

## WAIN Multi-pin Connectors For Vehicle

- Support power and signal at the same time



### Characteristics:



High-precision stamped contact for efficient crimping



Easy contact assembling without removing the housing



Support power and signal at the same time



With membrane wire seals that meet the requirements for IP67



Widely used in various fields such as vehicles construction machinery and automation equipment



Solid and reliable fast-locking technology

Note: For details, please refer to Q38 series P25Q-01~ P25Q-06

# Product applications

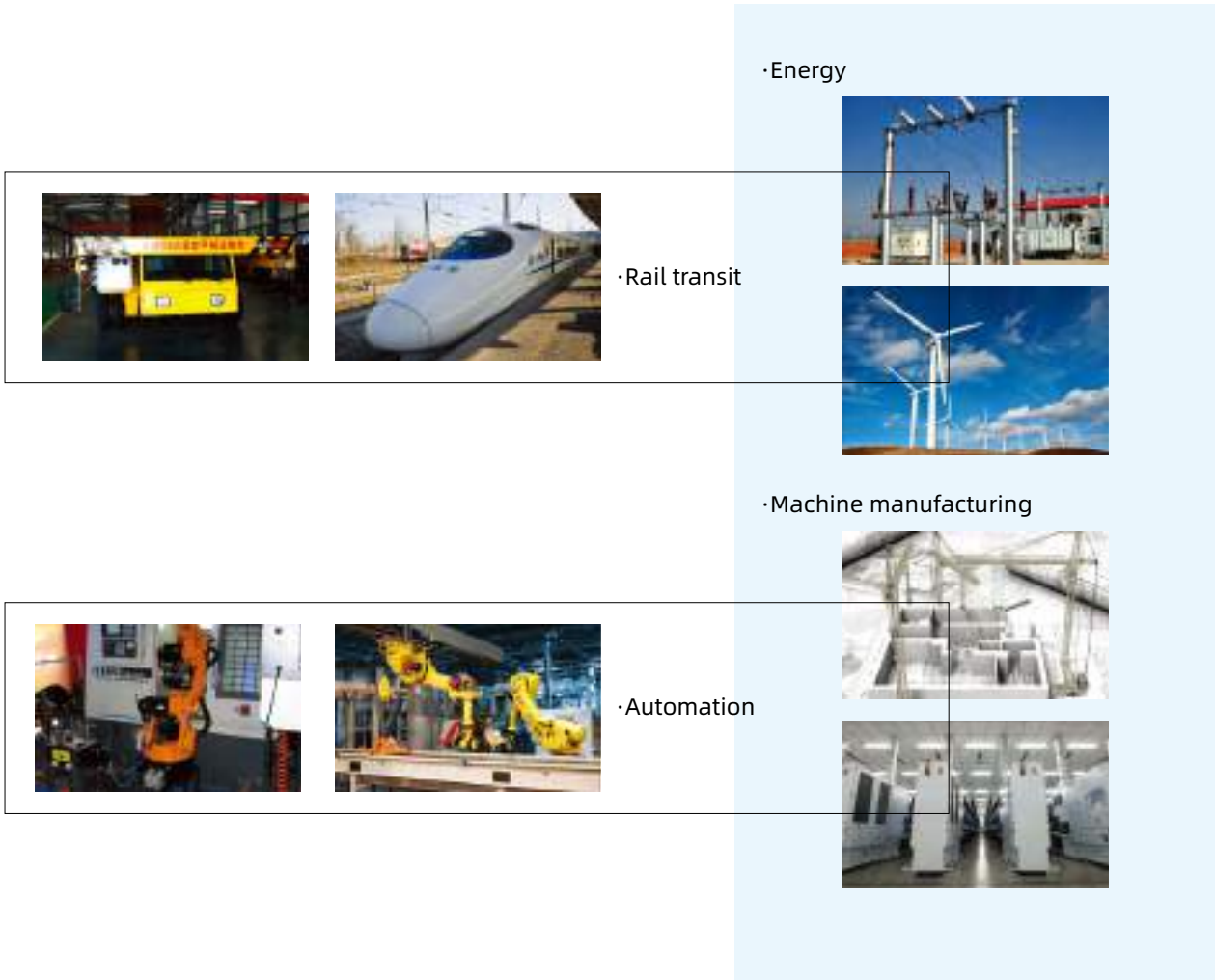



- Convenient maintenance
- Rapid surefooted installation
- Degree of protection IP68

» WAIN provides stable and reliable electrical connection for variable pitch blades and slip rings.



■ Turbine parts



■ Turbine parts



■ Pitch system



## 】】 Connectors in wind power generation

Wind power generation is the most mature way of power generation, which is qualified for large-scale development and has commercial development prospect., and it has been developed in the recent years. Reliable operation and convenient maintenance and replacement of functional module system are significant for the wind power station.

WAIN Connector provides reliable electrical connection solutions for wind power generation. The HC, HE, RJ45, HR23 series, as well as other series can satisfy various connection of weak and strong current in different applications of wind power.

### 】】 HK Combination Connectors

- Combination of power and signal area in one connector
- Up to 200A current connection
- Match with various kinds of hoods and housings
- An ideal connector for large current connection in narrow space

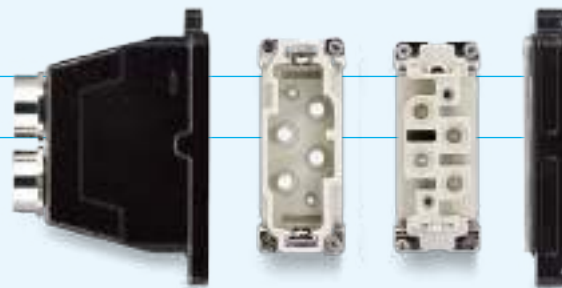

## ” Connectors in Electric power industry

Reliability, safety, economic efficiency, energy efficiency and environment–friendliness are important indicators of power grid operation. Therefore, new–type intelligent power grid taking physical power grid as foundation and integrating advanced sensor measurement technology, communication technology, information technology, computer technology and control technology is an important way to reach these indicators.

The various model of WAIN Connector also facilitates the safety, reliable operation and intelligent transformation of power grid.

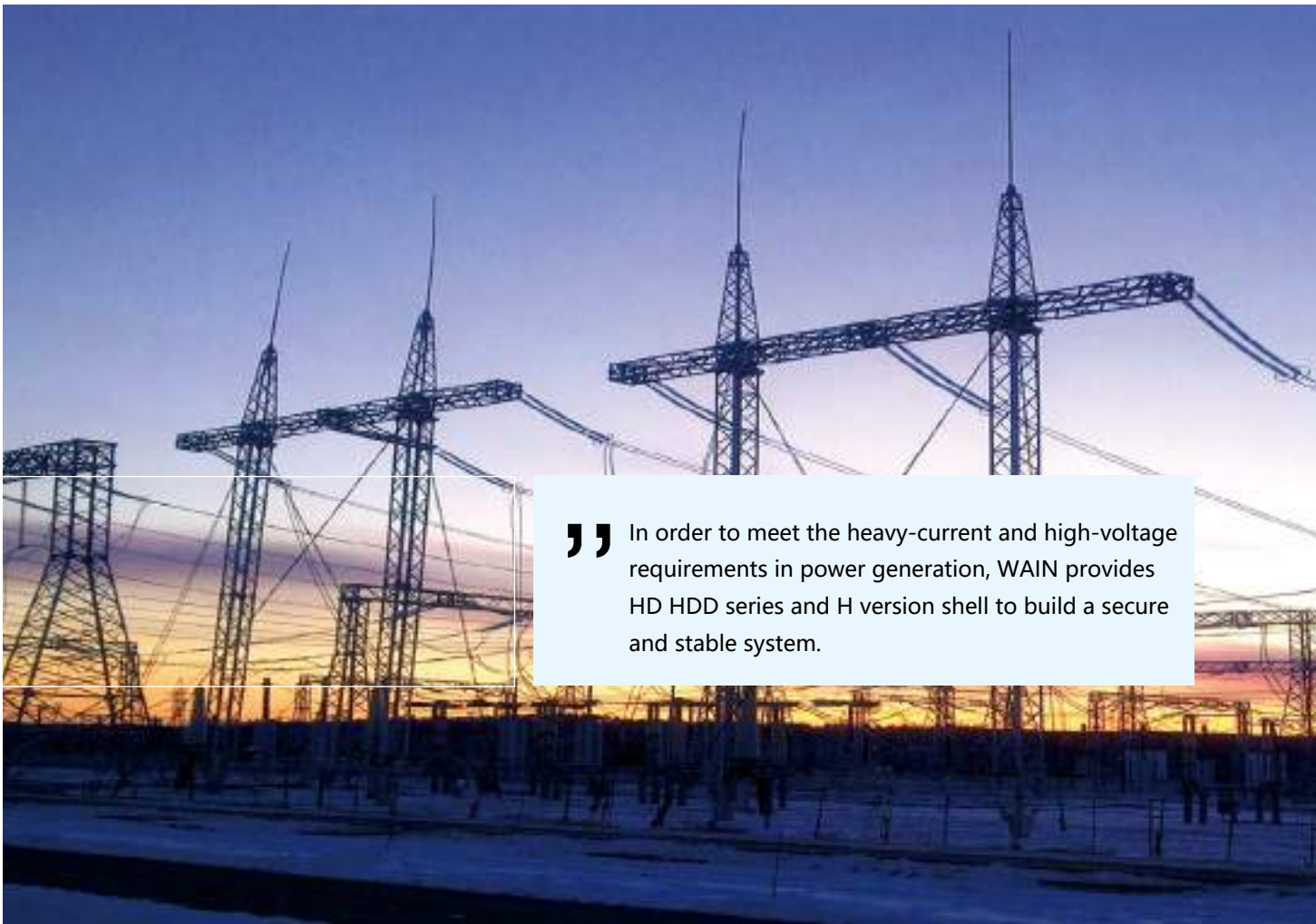

” In order to meet the heavy-current and high-voltage requirements in power generation, WAIN provides HD HDD series and H version shell to build a secure and stable system.



**»» HD HDD High-Density Inserts**

- Safe and reliable, convenient maintenance
- High density of crimping contacts, up to 216 contacts, compact structure
- Match with various kinds of hoods and housings



■ Vacuum circuit breaker



■ High-tension switch cabinet



■ Box-type substation

### » Connectors in Rail transit

Due to further specialization of labor and requirements for convenient maintenance, the modular design of components in the railway traffic technology is being attached with more and more attention. WAIN Connector provides a complete solution for different electrical connections among all kinds of components, ensuring the safe and reliable coordinated operation of each component in various environments.



### » HM Series Inserts: Flexible Combination

- Modular structure with high flexibility.
- Compact structure saves space.
- Connectors can be assembled according to special requirement.





■ Jumper wire



■ Coupling end



■ Coupling end



■ Hauling system

Product applications | **Automatization**



” WAIN uses single connector to achieve power and signal transmission so that robot wiring is more reasonable and engineering application can be carried out with high efficiency.



## » Use the least space to realize the automation

In the development of modern automation technology, flexibility is a very important indicator, including flexibility and convenience of installation, use, production and commissioning.

WAIN' s HE, HEE, HK, HM and other series, along with hoods and housings with various degrees of protection, cable outlets and locking levers, can satisfy the requirements for space and electrical connection.



## » HM Combined suite

- Modular structure
- Universality, reducing inventory
- Realize the power and signal transmission in the least space
- Meet electrical or signal connecting requirements in different fields and for different purposes



■ Outer join



■ Control system



■ Outer join

## Product applications | Machinery

### » Connector in machinery

In machinery manufacturing field, due to the diversified equipment and space requirements, light, gas and other media are also needed to be transmitted in some cases, besides weak current and strong current.

WAIN Connector provides integral solutions for this; it not only has many electrical connectors, but also has connectors for other media (such as pneumatic connector). It can satisfy different applications of various kinds of equipment, and simultaneously connect electrical circuit and gas circuit in a connector if necessary.

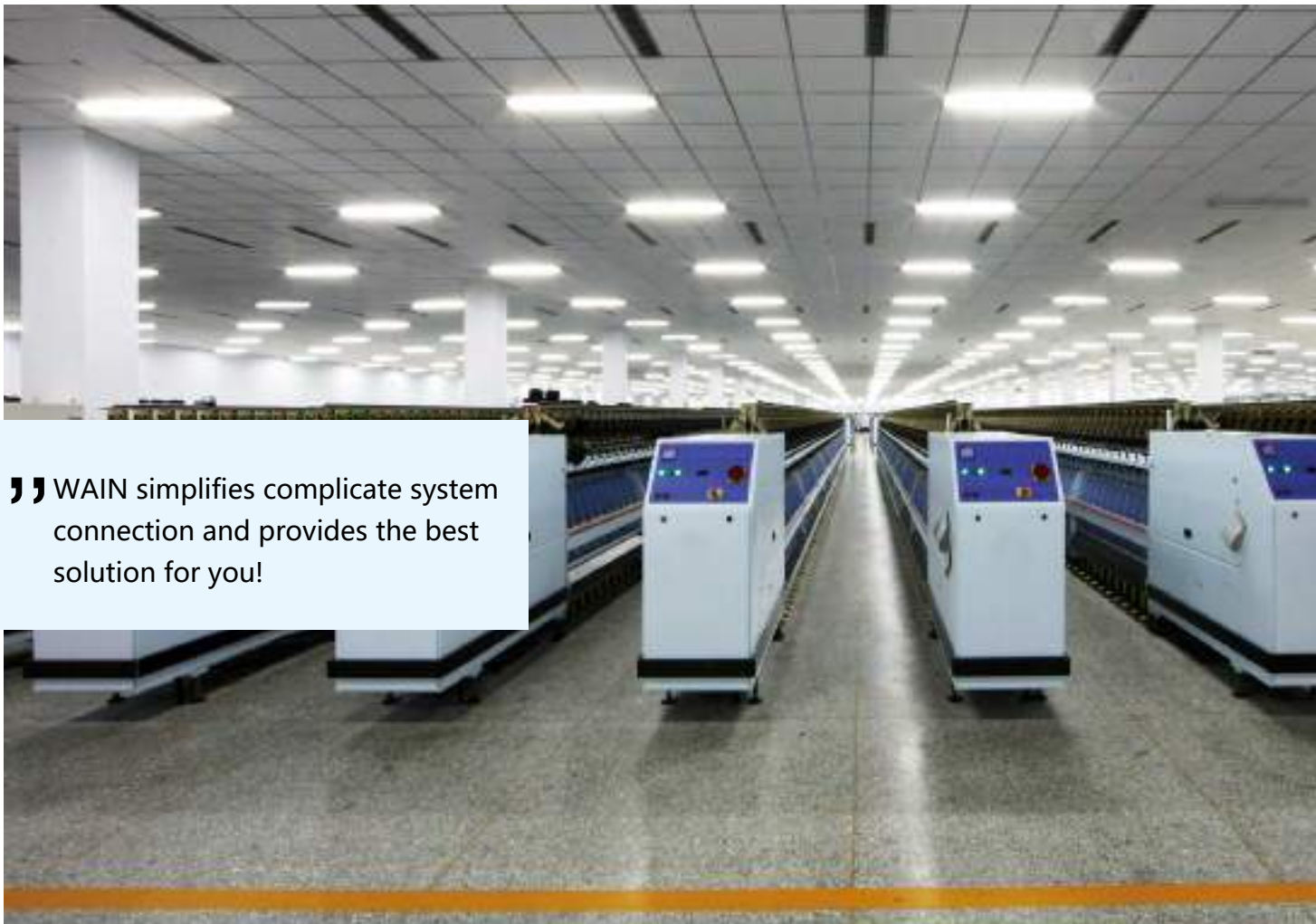

» WAIN simplifies complicate system connection and provides the best solution for you!





» HQ compact connectors

- Convenient maintenance
- Compact design
- Match pressure tight or EMC hoods/housings



### » Connector in engineering machinery

The future demands for diversification, high rise, beautiful appearance, energy conservation and environmental protection in construction industry will absolutely promote the development of engineering machinery.

WAIN Connector, boasting of dozens of series, thousand of models, strong current connection up to 650A and shells with IP65/IP68 protection grade, provides reliable electrical connection for the high-end and intelligent development of construction machinery.

\*The hoods/housings developed by WAIN for harsh environment reach a salt-spray protection of 500 hours. Compared with similar product around the world, it has more excellent protection capability.

\*Airtightness of fluororubber has formed standard adapter of WAIN product. Therefore, it can satisfy protection requirement under chemistry and chemical engineering environment.



» In the harsh environment, WAIN offers high protection grade connection scheme for the stability of the engineering machinery .



### HEE High density connectors

- High density of crimping contacts , up to 92 pins
- Polarised insert
- Contacts available with either hard silver plated or hard gold plated surface
- Various degrees of protection and cable entries for the hoods
- Airtightness of fluororubber
- Locking levers made of stainless steel



■ Engineering machinery



■ Engineering machinery



■ Engineering machinery

## Explain for Designation

### Hood

W24B-TE-4B-M25

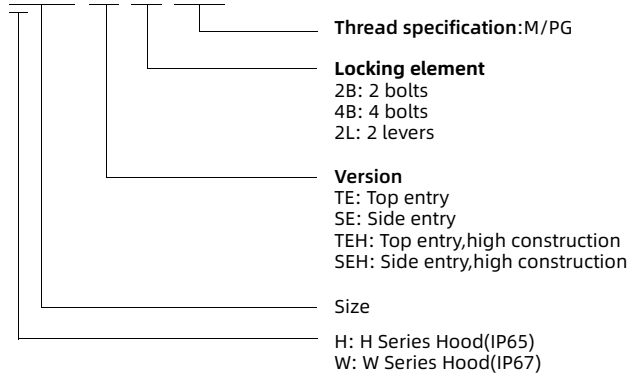

### Housing

W24B-BK-4B-CV

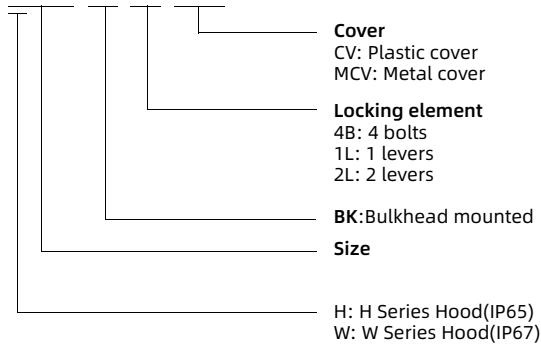

H24B-SF-1L-CV-M25

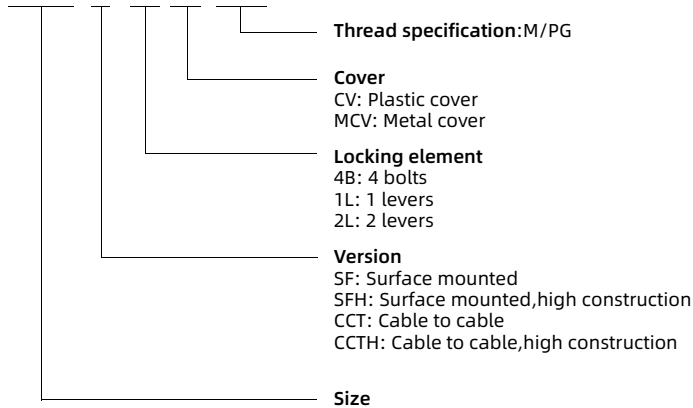

### Insert

HE-024-M

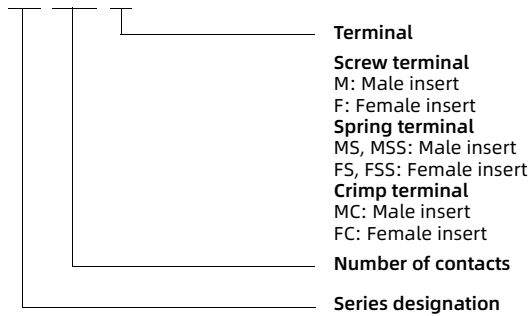

## Parts of the heavy duty connector

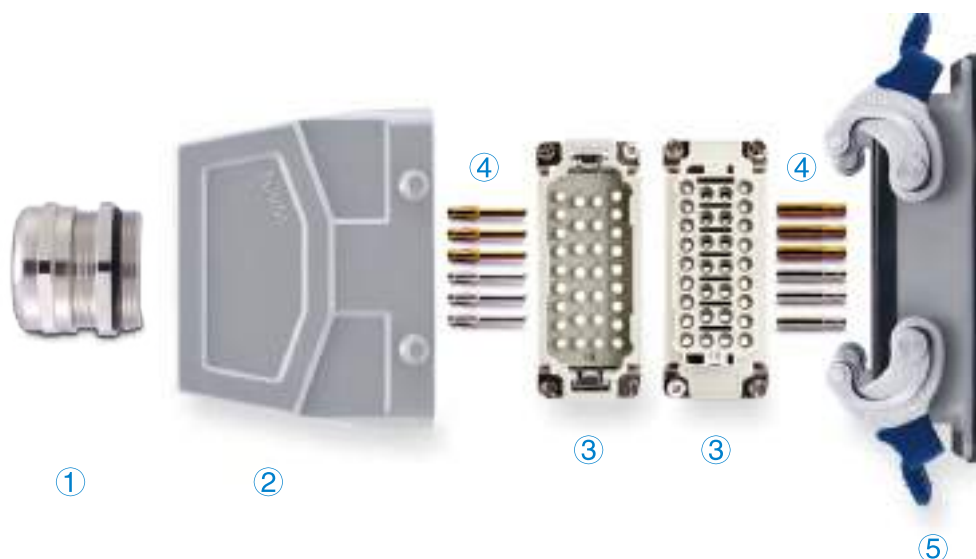









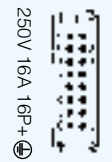

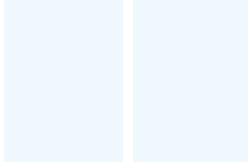

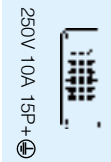

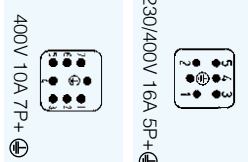

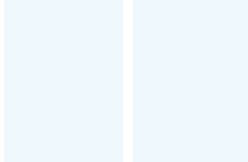
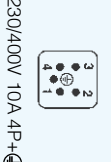
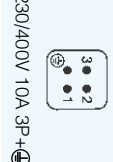
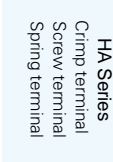

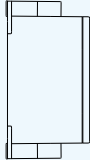
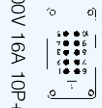
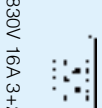
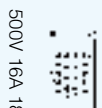
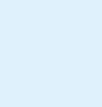

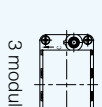

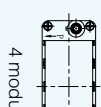
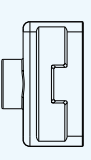

- ① **Cable gland**  
Nylon or brass nickel plated  
Universal cable glands  
Cable gland with normal or multiple seal  
Other Cable gland
- ② **Hoods**  
Low or high construction  
Top or side cable ent  
2 bolts or 4 bolts or 2 locking levers
- ③ **Male insert or Female insert**  
Screw terminal  
Crimp terminal  
Cage-clamp terminal  
Spring terminal
- ④ **Crimp contacts (only for crimp connection insert)**  
Golden plated or silver plated  
Rated current: 5A, 10A, 16A, 40A, 70A, 100A, 200A,300A, 350A, 650A, 1000A
- ⑤ **Housings**  
Bulkhead mounting or surface mounting or cable to cable  
Low or high construction  
1 or 2 locking levers or 4 bolts  
With or without thermoplastic/metal covers

Except standard hoods/housings, special hoods/housings with high protection level(IP68 ) and EMC screening are also available for clients.

\* For customized requirement, please contact us.

Product overview

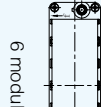
Hoods	Inserts		Housings
32A	16A	10A	
suitable for 2 Inserts of size 16 A	 <p>250V 16A 16P+ ⊕</p>	 <p>250V 16A 10P+ ⊕</p>	 <p>230/400V 10A 4P+ ⊕</p>
	 <p>250V 16A 16P+ ⊕</p>	 <p>250V 10A 15P+ ⊕</p>	 <p>230/400V 10A 4P+ ⊕</p>
			 <p>400V 40A 2P+ ⊕</p>
			 <p>230/400V 16A 5P+ ⊕</p>
			 <p>400V 10A 7P+ ⊕</p>
 <p>230/400V 10A 3P+ ⊕</p>	 <p>250V 10A 7P+ ⊕</p>	 <p>Axial screw terminal Crimp terminal</p>	

Hoods	Inserts							Housings
6B	HE Series Crimp terminal Screw terminal Spring terminal	HVE/HVES Series Screw terminal Spring terminal	HEE Series Crimp terminal	HD/HDD Series Crimp terminal	HSB Series Screw terminal	HK Series Screw terminal	HM Series Crimp terminal Screw terminal Spring terminal	
10B	 500V 16A 10P+ ⊕	 830V 16A 3+2P+ ⊕	 500V 16A 18P+ ⊕	 250V 10A 24P+ ⊕	 400/250V 70/16A 4/4P+ ⊕	 690/250V 70/16A 4/4P+ ⊕	 3 modules	
16B	 500V 16A 16P+ ⊕	 830V 16A 6+2P+ ⊕	 500V 16A 32P+ ⊕	 250V 10A 40P+ ⊕	 400/690V 35A 12P+ ⊕	 830/400V 80/16A 4/0P+ ⊕ 830/400V 80/16A 4/2P+ ⊕	 4 modules	
24B	 500V 16A 24P+ ⊕	 830V 16A 10+2P+ ⊕	 500V 16A 46P+ ⊕	 250V 10A 72P+ ⊕	 690/160V 40/10A 6/36P+ ⊕	 830/400V 80/16A 4/8P+ ⊕	 6 modules	
32B	suitable for 2 inserts of size 16 B							
48B	suitable for 2 inserts of size 24 B							

## Size of the Cable Entry

The adoption of metric threads considerably simplifies the understanding and specification of the size of cable entry as the product type description contains the thread dimension.

The following Cross Reference table shows the correlation between the PG versions and the new metric types.

Please notice that the maximum cable diameter may be reduced by the new metric cable glands.

PG	Cross reference	M
PG11	→	M20
PG13.5		
PG16	→	M25
PG21	→	M32
PG29	→	M40
PG36	→	M50
PG42	→	M63
PG48	→	M63

Below is shown the cable range of metric glands:

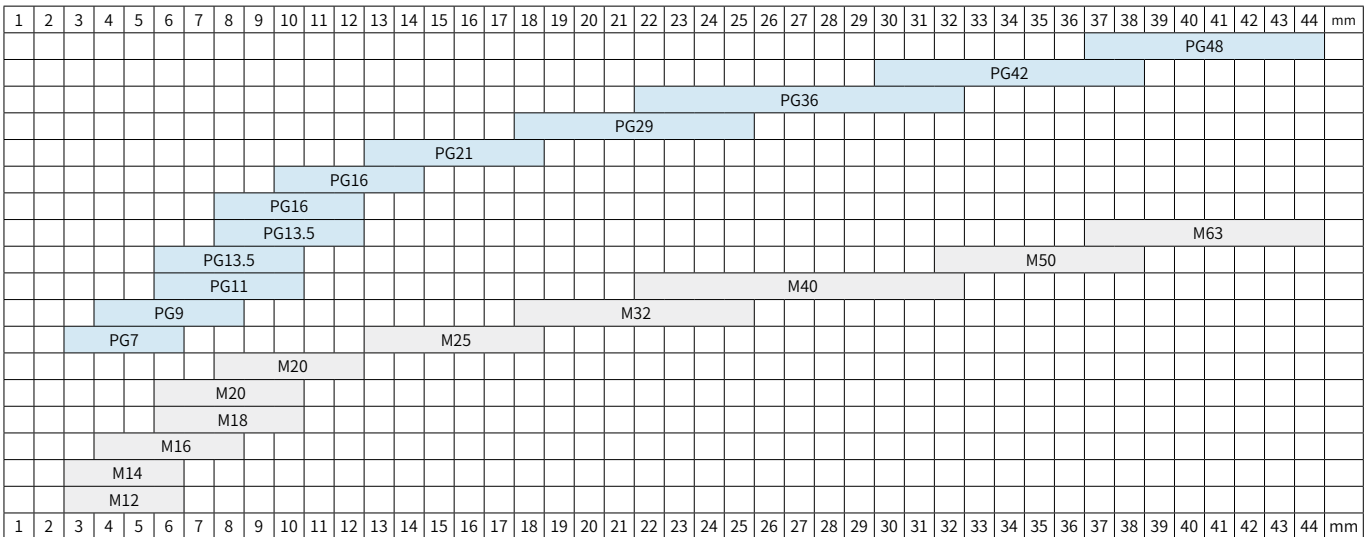

## Cable

The diagram shows different cable-diameters, being dependent on wire gauges and number of conductors. All data are averages for commercial cables.

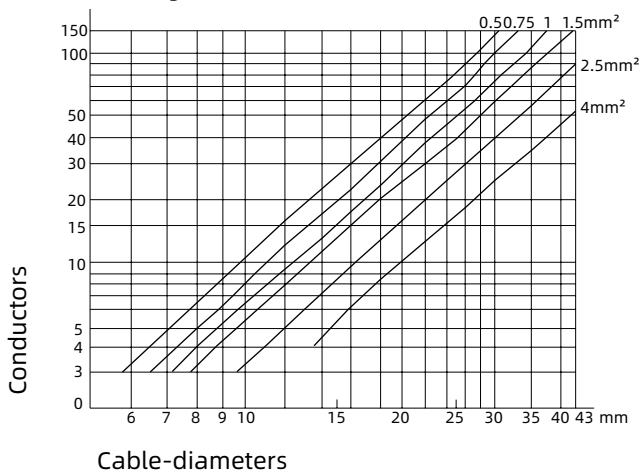



## Degree of Protection of Hoods/Housings







The connector's hood, housing, sealing and locking lever protect the inner components from external influences such as mechanical shocks, foreign bodies, humidity, dust, water or other fluids such as cleansing and cooling agents, oils, etc. The degree of protection the housing offers is explained in the IEC 60 529, DIN EN 60 529, standards that categorize enclosures according to foreign body and water protection.

The following table shows the different degrees of protection.

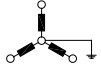
Code letters international protection		First index figure Foreign bodies protection		Second Index Figure Water protection	
IP		6		8	
Index figure	Degree of protection	Index figure	Degree of protection	Index figure	Degree of protection
0	No protection: No protection against accidental contact, no protection against solid foreign bodies.	0	No protection against water.		
1	Protection against large foreign bodies: protection against contact with any large area by hand and against large solid foreign bodies with $\varnothing > 50\text{mm}$ .	1	Drip-proof: Protection against vertical water drips.		
2	Protection against medium sized foreign bodies: protection against contact with the fingers, protection against solid foreign bodies with $\varnothing > 12\text{mm}$ .	2	Drip-proof: Protection against water drips (Up to a 15° angle)		
3	Protection against small solid foreign bodies: protection against tools, wires or similar objects $\varnothing > 2.5\text{mm}$ , protection against small foreign solid bodies with $\varnothing > 2.5\text{mm}$ .	3	Spray-proof: Protection against diagonal water drips (Up to 60° angle)		
4	Protection against grain-shaped foreign bodies: As 3 however, $\varnothing > 1\text{mm}$ .	4	Splash-proof: Protection against splashed water from all directions.		
5	Protection against injurious deposits of dust: Full protection against contact, protection against interior injurious dust deposits.	5	Hose-proof: Protection against water (out of a nozzle) from all directions.		
6	Protection against ingress dust: Total protection against contact, protection against penetration dust.	6	Protection against flooding: Protection against temporary flooding.		
		7	Protection against immersion: Protection against temporary immersion.		
		8	Water-tight: Protection against temporary Pressure.		
		9	Protected against water from high-pressure / steam jet cleaners		

## Electrical engineering data

### Rated impulse voltages (Table B2 of DIN EN 60 664-1)

Nominal voltage of the supply system (= rated insulation voltage of equipment)					Preferred values for the rated impulse voltage kV (1.2/50 us)			
					Overvoltage category			
					I	II	III	IV
Voltage line to earth derived from the nominal voltage of the supply system to the a.c. voltage (r.m.s. value) d.c. voltage	AC voltage (r.m.s. value) 	AC voltage   	AC voltage (r.m.s. value) d.c. voltage) 	AC voltage (r.m.s. value) d.c. voltage) 	Special protection levels	Level for electrical equipment (household and others)	Level for distribution supply systems	Input level
v	v	v	v	v				
100	66/115	66	66	-	0.5	0.8	1.5	2.5
150	120/208; 127/220;	115; 120; 127	110; 120;	220-110; 240-120	0.8	1.5	2.5	4
300	220/380; 230/400; 240/415; 260/440; 277/480;	220; 230; 240; 260; 277	220	440-220	1.5	2.5	4	6
600	347/600; 380/660; 400/690; 415/720; 480/830	347; 380; 400; 415; 440; 480; 500; 577; 600	480;	960-480	2.5	4	6	8
1000		660; 690; 720; 830; 1000	1000	-	4	6	8	12

#### Over-voltage category

The following categories in line with the standard IEC 60664-1

The overvoltage category is dependent on the mains voltage and the location at which the equipment is installed. It describes the maximum overvoltage resistance of a device in the event of a power supply system fault, e. g. in the event of a lightning strike. According to the relevant standards, there are 4 overvoltage categories.

Category I is equipment for connection to circuits in which measures are taken to limit transient overvoltages to an appropriately low level.

Note: Examples are protected electronic circuits

Category II is energy-consuming equipment to be supplied from the fixed installation.

Note: Examples of such equipment are appliances, portable tools and other household equipment with similar loads.

Category III is equipment in fixed installations and for cases where the reliability and the availability of the equipment is subject to special requirements.

Note: Examples of such equipment are switches in the fixed installation and equipment for industrial use with permanent connection to the fixed installation. WAN industrial connectors belong to the over-voltage type

Category IV is for use at the origin of the installation.

Note: Examples of such equipment are electricity meters and primary overcurrent protection equipment.

## Electrical engineering data

### Pollution degree

The following categories in line with the standard IEC 60664-1

The dimensioning of operating equipment is dependent on environmental conditions. Any pollution or contamination may give rise to conductivity that, in combination with moisture, may affect the insulating properties of the surface on which it is deposited. The pollution degree influences the design of components in terms of the creepage distance. The pollution degree is defined for exposed, unprotected insulation on the basis of environmental conditions

### Pollution degree I

No pollution or only dry, non-conductive pollution occurs. The pollution has no influence, such as computer and measuring instrument rooms, for example.

### Pollution degree II

Only non-conductive pollution occurs except that occasionally a temporary conductivity caused by condensation is to be expected, such as residential, sales, laboratories, precision engineering workshops, for example.

### Pollution degree III

Conductive pollution occurs or dry nonconductive pollution occurs which becomes conductive due to condensation which is to be expected, such as unheated storage premises, workshops or boiler rooms, also for the electric components of assembly or mounting equipment and machine tools, for example. **WAIN heavy duty connectors are designed as standard for the Pollution Degree.**

### Pollution degree IV

The pollution generates persistent conductivity caused by conductive dust or by rain or snow, such as in the environment of outdoor.

### Special ruling for connectors

Subject to compliance with certain preconditions, the standard for connectors permits a lower pollution degree than that which applies to the installation as a whole. This means that in a pollution degree 3 environment, connectors may be used which are electrically rated for pollution degree 2.

Extract from DN EN 61 984, Para 6.19.2.3.

For a connector with a degree of protection IP54 or higher according to EC 60529, the insulating parts inside the enclosure may be dimensioned for a lower pollution degree, This also applies to mated connectors where enclosure is ensured by the connector housing and which may only be disengaged for test and maintenance purposes.

The conditions fulfill:

- a connector which is protected to at least IP54 acc. to IEC 60 529
- a connector which is installed in a housing and which as described in the standard is disconnected for testing and maintenance purposes only.
- a connector which is installed in a housing and which when disconnected is protected by a cap or cover to at least IP54.
- a connector located inside a switching cabinet to at least IP54.

Note: These conditions do not extend to connectors which when disconnected remain exposed to the industrial atmosphere for an indefinite period.

Typical applications in which to choose pollution degree 2 connectors:

- A connector serving a drive motor which is disconnected only for the purpose of replacing a defective motor, even when the plant or system otherwise calls for pollution degree 3.
- Connectors located inside a switching cabinet to IP54, In such cases, it is even possible to dispense with the IP54 housings of the connectors themselves,
- Connectors serving a machine of modular design which are disconnected for transport purposes only and enable rapid erection and reliable commissioning. In this case, protective covers or adequate packing must be provided to ensure that the connectors are not affected by pollution/contamination.

## Terminations technology

### Screw terminal

#### Advantages

- Wide scope of applicable wire specification;
- No special tool needed;
- Protection plate of wire is available;
- A single hole can be connected to several wires at the same time if necessary;
- Insert has contact pins itself, easy to reduce inventory.

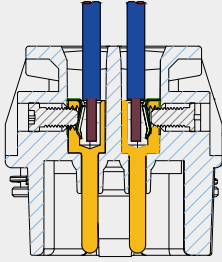

Screw terminal is accord to VDE 0609/EN 60 999. Test dimensions and tightening torques are shown in the list following.

Dimensions and tightening torque of screw terminals.

Wire gauge (mm <sup>2</sup> )	1.5	2.5	4	6	10	16
Screw thread	M3	M3	M3.5	M4	M4	M6
Test moment of torque (Nm)	0.5	0.5	0.8	1.2	1.2	1.2*
min. pull-out for stranded wire(N)	40	50	60	80	90	100

\*For fixed screws without heads

For fixed screws without heads

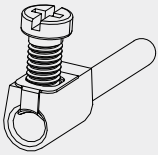

The ferrules is not necessary to use for:  
HSB series, HVE series, HK-006/12, HK-006/6

Terminals without wire protection

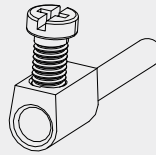

The insulation is to be removed and use the wire ferrules:  
HK-004/0, HK-004/2, HK-004/8

#### Screw terminal

Inserts	Wire protection		min. wire gauge		max. wire gauge		Stripping length mm
	Yes	No	mm <sup>2</sup>	AWG	mm <sup>2</sup>	AWG	
HA-003/HA-004		✓	0.75	18	1.5	16	4.5
HA-010/HA-016/HA-032	✓		0.75	18	2.5	14	7.5
HE Series, HVE Series	✓		0.75	18	2.5	14	7.5
HSB Series	✓		1.5	16	6	10	11.5
HK-006/6, HK-006/12(signal contacts)	✓		0.2	24	2.5	14	7.5
HK-004/2, HK-004/8(signal contacts)		✓	0.5	20	2.5	14	7.5
HK-004/0, HK-004/2, HK-004/8(power contacts)		×	1.5	16	16	6	14
HD AV Series, HE AV Series	✓		0.2	24	2.5	14	8..11

## Terminations technology

### Screw terminal

#### Recommendation of tightening torque and screwdriver types for inserts connecting with screws

Screw type	Screws classification	Inserts	tightening torque recommendation(Nm)	tightening torque recomma (Lbft)	screwdriver types recommendation
M3	screw terminal	HA-003/HA-004、HQ-005/HQ-007/HQ-012 (PE)	0.25	0.20	cross screwdr PH0
	screw terminal	HD AV, HE AV, HK-006/6(signal pin), HK-006/12 (signal pin)	0.50	0.40	slot type screwdriver 0.5x3.0
	screw terminal	HA-010/HA-016/HA-032, HVE, HE, HME-005, HWK-006/6(signal pin)	0.50	0.40	slot type screwdriver 0.6x3.5 or cross screwdriver PH1
	Screws fixed on the 3A Hoods/Housings	HA-002/HA-003/HA-004、HD-007/HD-008、HQ-001/HQ-002/HQV-002/HQ-003/HQ-005/HQ-007/HQ-012/HQ-021	0.50	0.40	cross screwdriver PH1or cross screwdriver PH2
	Screws fixed on the H10A/H16A/H32A Hoods/Housings, HB Hoods/Housings	HA-010/HA-016/HA-032、HE、HVE、HEE、HEEE、HD-015 HD-025/HD-050/HD-040/HD-064/HD-080/HD-128、HDD、HSB、HK、HWK、HKH、HE AV、HD AV、HSC	0.50	0.40	slot type screwdriver 0.6x3.5 or cross screwdriver PH1 or cross screwdriver PH2
	Coding Pin	CODE-M3、M3CODE-M3、GBUSH-M3、GPIN-M3、MGBUSH-M3、MGPIN-M3	0.50	0.40	slot type screwdriver 1x6.0
M3.5	Ground terminal	HA-010/HA-016/HA-032、HD-015/HD-025	0.80	0.60	slot type screwdriver 0.6x3.5 or cross screwdriver PH1
M4	screw terminal	HSB-006/HSB-012/HSC-006	1.20	0.90	slot type screwdriver 0.6x3.5 or cross screwdriver PH1
	Ground terminal	HE、HVE、HD-040/HD-064/HD-080/HD-128、HDD、HE AV、HD AV、HK-008/24、HWK-006、HK-006/6、HK-006/12、HK-008/0、HSB-006/HSB-012、HK-009/9/18、HK-032/55、HK-009/12/25	1.20	0.90	slot type screwdriver 0.8x4.5 or cross screwdriver PH2
M5	screw terminal	HWK-006/6(power pin)	2.00	1.40	slot type screwdriver 0.8x4.5
	Ground terminal	HK-012/2、HKH-012/0、HK-004/0、HK-004/2、HK-004/8、HK-006/36	2.00	1.40	slot type screwdriver 0.8x4.5 or cross screwdriver PH2
M6	screw terminal	HK-004/0(power pin), HK-004/2 (power pin), HK-004/8(power pin)	the corresponding technical data please see chapter 8		slot type screwdriver 0.8x4.5
slot type screwdriver according to ISO 2380 cross screwdriver according to ISO 8764					

Increasing the tightening torque does not improve considerably the contact resistances. The torque moments were determined when optimum mechanical, thermal and electrical circumstances were given. If the recommended figures are considerably exceeded the wire or the termination can be damaged.

## Terminations technology

### Crimp connection

#### Advantages

Applicable to vibration situation;  
Density of the contact pin is high;  
Nearly cold welding guarantees corrosion resistance;  
Able to achieve pre-assembly of wiring harness;  
The same insert can be used for different coated pins according to actual demand.

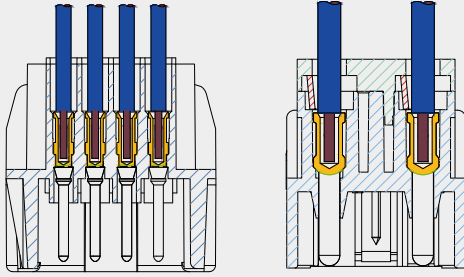

A perfect crimping can realize air tight state, and has the effect of cold welding. To achieve high-quality crimping requires the coordination of crimping parts and crimping tools, the crimped wires must match the correct specifications of crimping pieces. As long as these basic requirements are met, the user can ensure a connection with low contact resistance and high corrosion resistance.

The requirements for crimping connectors shall be in accordance with DIN EN60 352-2 as following table.

#### Tensile strength:

The tensile strength of the contact wire at the terminal can be used to judge the crimping quality of the conductor. The relationship between tensile strength and cross section area of conductor is defined under DIN EN60 352-2.

Using the Wain crimping tool can ensure the required tensile strength in the correct application process.

#### Crimping tools

The crimping tool (hand or automatic) is designed to make the connecting parts of contact or wire deform uniformly under the pressure of pliers, to ensure the uniform extension of material.

#### Overview inserts with crimp terminal

Wire gauge		Internal diameter Ø (mm)	Stripping length l (mm)		
(mm <sup>2</sup> )	AWG		HD HDD R15 Modular (10A)	HE HA HvE (16A)	HC (40A)
0.14 ... 0.37	26 ... 22	0.9	8	-	-
0.5	20	1.15	8	7.5	-
0.75	18	1.3	8	7.5	-
1	18	1.45	8	7.5	-
1.5	16	1.75	8	7.5	9
2.5	14	2.25	6	7.5	9
4	12	2.85	-	7.5	9.6
6	10	3.5	-	-	9.6
10	8	4.6	-	-	15

	Conductor cross-section	Ø	Stripping length
100 A Modul	10 mm <sup>2</sup>	4.3 mm	19.0 mm
	16 mm <sup>2</sup>	5.5 mm	19.0 mm
	25 mm <sup>2</sup>	7.0 mm	19.0 mm
	35 mm <sup>2</sup>	8.2 mm	16.0 mm
HC Modular 350	35 mm <sup>2</sup>	8.2 mm	26.0 mm
	50 mm <sup>2</sup>	10.0 mm	28.0 mm
	70 mm <sup>2</sup>	11.5 mm	28.0 mm
	95 mm <sup>2</sup>	13.5 mm	30.0 mm
HC Modular 650	120 mm <sup>2</sup>	15.5 mm	24.0 mm
	240 mm <sup>2</sup>	22.5 mm	50.0 mm
for fine stranded wires according to IEC 60 228 class 5			

#### Tensile strength of crimped connections (Table 1: DIN EN 60 352-2)

Conductor cross-section		Tensile strength
mm <sup>2</sup>	AWG	N
0.05	30	6
0.08	28	11
0.12	26	15
0.14		18
0.22	24	28
0.25		32
0.32	22	40
0.5	20	60
0.75		85
0.82	18	90
1.0		108
1.3	16	135
1.5		150
2.1	14	200
2.5		230
3.3	12	275
4.0		310
5.3	10	355
6.0		360
8.4	8	370
10.0		380

#### The selection of contact surface plated

Below is a table derived from actual experiences

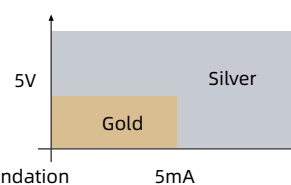

Notes: The tools for crimp terminal may influence the product quality and stability. Please select the tools recognized by our company.

## Terminations technology

### Axial screw terminal

#### Advantages

- Scope of applicable wire specification is wide;
- Special tool will not be used;
- Little space required;
- Simple operation;

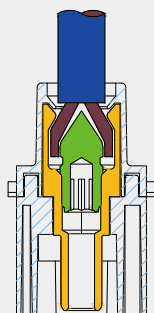

#### Technical notes for Axial screw terminal:

The wire gauge (sectional area) mentioned in the catalogue refers to the geometric wire gauge (sectional area) of the cable.

#### Background:

According to DIN VDE 0295 for cables and insulated wires, the sectional area of cables is measured according to the conductance ( $\Omega / \text{km}$ ) and the maximum diameter of wire. The minimum diameter of wire is not specified. For example (rated sectional area  $95\text{mm}^2 \rightarrow$  actual geometric sectional area  $89\text{mm}^2$ )

#### Suggestions:

If there is a big difference between the geometric cross-sectional area and the rated cross-sectional area of the cable, additional detection should be carried out when axial screw terminal is used.

#### Stress relief:

For safe operation, there should be enough distance between the cable and the pressure contact to ensure that the contact is not affected by radial stress. Specific stress relief designs can be found in DIN VDE 0100-520:2003-6 (refer to the table below).

#### Axial screw crimping instruction

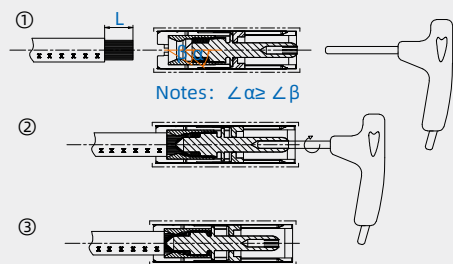

- ① .Strip insulation from the wire, the length as per the form and insert the wire into the contact until insulation layer is flush with the wiring access of the contact. Do not twist the strands of the wire.
- ② .Hold the wire in position and tighten the wire from the mating side by a twist driver (SW-2x40), the tightening torque reference the form.
- ③ .Complete wiring .

Outer cable diameter (mm)	Maximum fixing distance (mm)	
	horizontal	vertical
$D \leq 9$	250	400
$9 < D < 15$	300	400
$15 < D < 20$	350	450
$20 < D < 40$	400	550

#### Cable:

The axial screw terminal technology was developed based on DIN EN 60 228 class 5 cables (cable assembly according to DIN EN 60 228). Different cable assemblies need to be tested independently.

#### Assembly remarks:

Before assembly, the user must ensure that the axial taper thread completely opens the contact chamber downward. After the cable insulation is stripped, do not twist the strands, and the longest stripping length should not exceed the recommended dimension. Insert the cable completely into the connector and make direct contact with the bottom of the copper strand. Maintain the cable in this position when using the recommended tightening torque.

#### Maintenance of axial screw terminal:

After initial assembly, only use the recommended tightening torque once again to avoid damaging the individual wire strands.

Wire gauge (mm <sup>2</sup> )	Stranded wires DIN EN 60 228 class 2	Fine stranded wires DIN EN 60 228 class 5	Super fine stranded wires DIN EN 60 228 class 6			
0.5	7 x 0.30	16 x 0.20	28 x 0.15	64 x 0.10	131 x 0.07	265 x 0.05
0.75	7 x 0.37	24 x 0.20	42 x 0.15	96 x 0.10	195 x 0.07	384 x 0.05
1	7 x 0.43	32 x 0.20	56 x 0.15	128 x 0.10	260 x 0.07	512 x 0.05
1.5	7 x 0.52	30 x 0.25	84 x 0.15	192 x 0.10	392 x 0.07	768 x 0.05
2.5	7 x 0.67	50 x 0.25	140 x 0.15	320 x 0.10	651 x 0.07	1280
4	7 x 0.85	56 x 0.30	224 x 0.15	512 x 0.10	1040 x 0.07	
6	7 x 1.05	84 x 0.30	192 x 0.20	768 x 0.10	1560 x 0.07	
10	7 x 1.35	80 x 0.40	320 x 0.20	1280 x 0.10	2600 x 0.07	
16	7 x 1.70	128 x 0.40	512 x 0.20	2048 x 0.10		
25	7 x 2.13	200 x 0.40	800 x 0.20	3200 x 0.10		
35	7 x 2.52	280 x 0.40	1120 x 0.20			
50	19 x 1.83	400 x 0.30	705 x 0.30			
70	19 x 2.17	356 x 0.50	990 x 0.30			
95	19 x 2.52	485 x 0.50	1340 x 0.30			
120	37 x 2.03	614 x 0.50	1690 x 0.30			
150	37 x 2.27	765 x 0.50	2123 x 0.30			
185	37 x 2.52	944 x 0.50	1470 x 0.40			
240	61 x 2.24	1225 x 0.50	1905 x 0.40			

## Terminations technology

## Overview inserts with axial screw terminal

Insert	Wire gauge	Stripping length	Tightening torque	Max. cable insulation diameter	Size hexagon recess	Insert dimension for cable indication (ISK)
	(mm <sup>2</sup> )					
HK-006/12	2.5-8	2.5 mm <sup>2</sup> : 8+1 4 mm <sup>2</sup> : 8+1 6 mm <sup>2</sup> : 8+1 8 mm <sup>2</sup> : 8+1	2.5 mm <sup>2</sup> : 1.5 4 mm <sup>2</sup> : 1.5 6 mm <sup>2</sup> : 2 8 mm <sup>2</sup> : 2	6.2	2	4.7
	6-10	6 mm <sup>2</sup> : 8+1 8 mm <sup>2</sup> : 8+1 10 mm <sup>2</sup> : 8+1	6 mm <sup>2</sup> : 2 8 mm <sup>2</sup> : 2 10 mm <sup>2</sup> : 2	6.2	2	4.7
HK-006/6	16 - 35	13+/-1	16 mm <sup>2</sup> : 6 25 mm <sup>2</sup> : 7 35 mm <sup>2</sup> : 8	11.4	4	4.9
HK-008/0	10 - 25	13+/-1	10 mm <sup>2</sup> : 6 16 mm <sup>2</sup> : 6 25 mm <sup>2</sup> : 8	11.4	4	4.75
HQV-002 HQ-002/0 High Voltage	2.5-10 2.5-10	8+1 PE: 2 mm	1.8	7.3	2	5.6
200 A module without PE 200 A module with PE	25-40	25 mm <sup>2</sup> : 16 40 mm <sup>2</sup> : 16	25 mm <sup>2</sup> : 8 40 mm <sup>2</sup> : 8	12 16	5	3
200 A module without PE 200 A module with PE	40-70	40 mm <sup>2</sup> : 16 70 mm <sup>2</sup> : 16	40 mm <sup>2</sup> : 9 70 mm <sup>2</sup> : 10	12 16	5	3
100 A module	10-25	13+/-1	10 mm <sup>2</sup> : 6 16 mm <sup>2</sup> : 6 25 mm <sup>2</sup> : 7	11.4	4	4.9
	16-35	13+/-1	16 mm <sup>2</sup> : 6 25 mm <sup>2</sup> : 7 35 mm <sup>2</sup> : 8	11.4	4	4.9
70 A module	6-16	6 mm <sup>2</sup> : 8+1 8 mm <sup>2</sup> : 8+1 10 mm <sup>2</sup> : 8+1	6 mm <sup>2</sup> : 2 10 mm <sup>2</sup> : 3 16 mm <sup>2</sup> : 4	8.9	2.5	7.4
	14-22	12.5+1	14 mm <sup>2</sup> : 4 16 mm <sup>2</sup> : 4 22 mm <sup>2</sup> : 5	10	2.5	5.9
40 A module	2.5-8	2.5 mm <sup>2</sup> : 5+1 4 mm <sup>2</sup> : 5+1 6 mm <sup>2</sup> : 8+1 8 mm <sup>2</sup> : 11+1	2.5 mm <sup>2</sup> : 1.5 4 mm <sup>2</sup> : 1.5 6 mm <sup>2</sup> : 2 8 mm <sup>2</sup> : 2	4 4 6 8.2	2	4.7
	6-10	6 mm <sup>2</sup> : 8+1 10 mm <sup>2</sup> : 11+1	6 mm <sup>2</sup> : 2 10 mm <sup>2</sup> : 2	6 10.5	2	4.7
Module with axial screw terminal	2.5-8 6-10	2.5 mm <sup>2</sup> : 5+1 4 mm <sup>2</sup> : 5+1 6 mm <sup>2</sup> : 8+1 10 mm <sup>2</sup> : 11+1	2.5 mm <sup>2</sup> : 1.5 4 mm <sup>2</sup> : 1.5 6 mm <sup>2</sup> : 2 10 mm <sup>2</sup> : 2	4 4 6 8.2	2	5.2
HK-003/0 straight	35-70	22	35 mm <sup>2</sup> : 8 50 mm <sup>2</sup> : 9 70 mm <sup>2</sup> : 10	15	5	8.2
HK-003/0 angled	35-70	22	35 mm <sup>2</sup> : 8 50 mm <sup>2</sup> : 9 70 mm <sup>2</sup> : 10	15	5	9
HK-003/2 straight	35-70	22	35 mm <sup>2</sup> : 8 50 mm <sup>2</sup> : 9 70 mm <sup>2</sup> : 10	15 PE: 10	5	8.2 PE: 7.2
HK-003/2 angled	35-70	22	35 mm <sup>2</sup> : 8 50 mm <sup>2</sup> : 9 70 mm <sup>2</sup> : 10	15 PE: 10	5	9.0
HC Modular 650	70-120	23+2	70 mm <sup>2</sup> : 12 95 mm <sup>2</sup> : 14 120 mm <sup>2</sup> : 16	26.5	8	28
	150-185	23+2	150 mm <sup>2</sup> : 17 185 mm <sup>2</sup> : 18	26.5	8	28



## Terminations technology

### Spring terminal

#### Advantages

No special tool needed;  
Applicable to vibration situation;  
Insert has contact pins itself, easy to reduce inventory.

#### Spring terminal

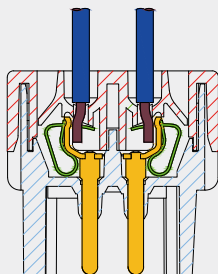

#### Double spring connection

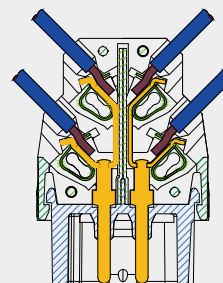

#### Spring terminal-connection step

Screwdriver width: 3.0 x 0.5 mm ①

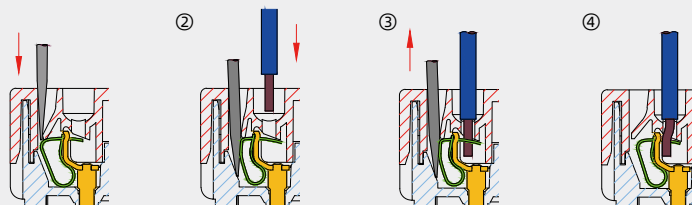

Inserts	max. wire gauge		Stripping length
	(mm <sup>2</sup> )	AWG	l (mm)
HE Spring terminal, HVE Spring terminal	0.14 ... 2.5	26 ... 14	7 ... 9
HE Double spring connection	0.14 ... 2.5	26 ... 14	9 ... 11
HK-004/4	0.14 ... 2.5	26 ... 14	7 ... 9
HME-005-MS/FS	0.14 ... 2.5	26 ... 14	7 ... 9

### Wrap terminal

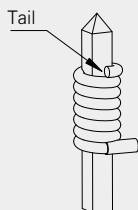

The characteristic of wrap terminal:

Solderless wrap connection technology, is to use a special tool-winding device, exerts a pulling force to the single unit solid bare wire, make it according to the prescribed number of turns in a tightly ling edges

at the terminal, so that the wire and the terminal form firm joints technology, so as to achieve a reliable electrical connection. It is different from screw connection, welding, crimping, piercing connection way.

Advantage:

Wrap connection has more advantage than solder connection, see the following ;

- ① Higher reliability, longer working life;
- ② The junction is durable, anti-fatigue, corrosion resistance;
- ③ Production quality is stable, neat appearance, easier operation, and eliminate the virtual welding problems of the solder connection;
- ④ Achieve high density mounting and product miniaturization.
- ⑤ Reduce manufacture costs and improve work efficiency.

## Terminations technology

### Spring terminal

#### HE push spring insert

##### Characteristics of the product:

The product can be connected and disassembled in limited space without special tool. Installation and disassembly can't be disturbed by tools, operation is convenient; Furthermore, during connection and disassembly, the hole can be opened through pushing the corresponding lever. To make it more efficient, all the holes can be opened with a slotted screwdriver simultaneously. The tool is not contacted to the conductor while operating, therefore it avoids electric shock.

#### Assembly instructions

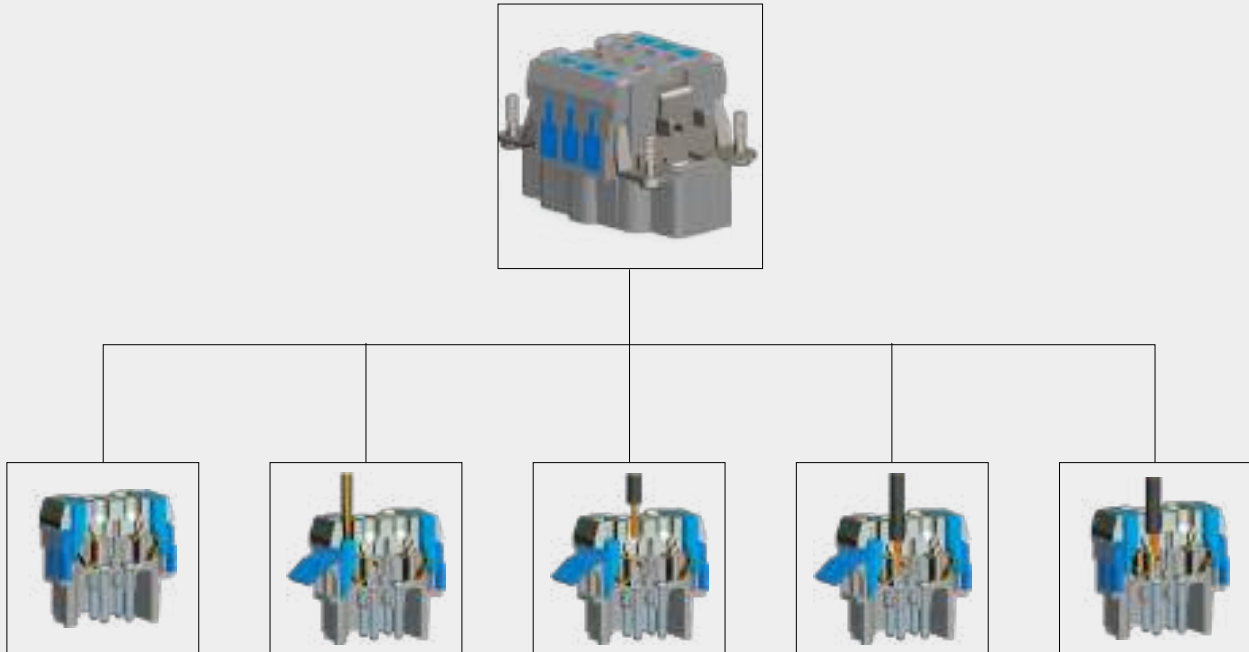

step 1: Strip the insulate layer by 9-11mm;

step 2: Using slotted screwdriver of spec. 0.5\*3 to insert into groove of rectangle pushing lever, and push to the bottom, to let the driving lever tilt out. At this moment the spring stabilizes at opening condition.

step 3: Insert striped wire/cable into the round hole.

step 4: Reset the driving lever until hearing the "bang", which indicates the pushing lever automatically reset and the spring shut, the wire/cable and contact are connected securely.

step 5: Installation is completed.

### Tools

HE B Spring open machine<sup>1)</sup>



Description	Designation	Order NO.
for all HE B spring inserts	SOM01	198 001 003 0008

1) It can open all the shrapnel windows of insert at one time; suitable for using in mass assembly, greatly improving the efficiency of the connection.

## Hoods/Housings

### Screw tightening torque

Recommended tightening torque for bulkhead mounted housings

Series	Number of screws	Size of screws	Recommended Tightening torque (Nm)	Remarks
H3A	2	M 3	0.8 ... 1.0	Gasket
H10A / 16A	4	M 3	0.8 ... 1.0	Gasket
H32A	4	M 4	0.8 ... 1.0	Gasket
H6B / H10B / H16B / H24B	4	M 4	0.8 ... 1.0	Gasket
H32B	4	M 5	min. 2.5	Gasket
H48B	4	M 6	min. 3.0	O-ring
HP3A	2	M 4	min. 1.0	O-ring
HP6B / HP10B / HP16B / HP24B	4	M 6	min. 3.0	O-ring
HP6B/H / HP10B/H / HP16B/H / HP24B/H	4	M 6	min. 3.0	O-ring

To offer safe protection the surface condition for mounting panel should be according to DIN 4766:

Waviness  $\leq 0.2$  mm on 200 mm distance

Roughness  $R_a \leq 16$   $\mu\text{m}$

# HA SERIES

Compact standard connector



# HA SERIES The slim inserts

## Technical characteristics

Specifications	DIN EN 60 664 DIN EN 61 984
Approvals	
Inserts	
Number of contacts	3,4,10,16,32(2X16)+PE
Electrical data acc. to EN 61 984	
HA-002/HA-003/HA-004	
-Rated current	10A
-Rated voltage conductor-ground	230V
-Rated voltage conductor-conductor	400V
-Rated impulse voltage	4kV
-Pollution degree	3
-or	10A 250V 4kV 3
HA-010/HA-016	
-Rated current	16A
-Rated voltage	250V
-Rated impulse voltage	4kV
-Pollution degree	3
-Pollution degree 2 also	16A 250V/400V 4kV 2
Rated voltage acc. to UL	600V
Insulation resistance	$\geq 10^{10}\Omega$
Material	polycarbonate
Limiting temperatures	-40°C ...+125°C
Flammability acc. to UL 94	V0
Mechanical working life (mating cycles)	$\geq 500$
Contacts	
Material	copper alloy
Surface	hard-gold plated hard-silver plated
Contact resistance	$\leq 1m\Omega$
Screw terminal	
-Wire gauge	0.75-1.5mm <sup>2</sup> (HA-003/004) 0.75-2.5mm <sup>2</sup> (HA-010/016) 0.75-2.5mm <sup>2</sup> (HA-003-M/F-V2)
- AWG	18-16 (HA-003/004) 18-14 (HA-010/016)
- Tightening/Test torque	0.25Nm (HA-003/004) or 0.5Nm (HA-010/016)
Crimp terminal	
-Wire gauge	0.14-4.0mm <sup>2</sup>
-AWG	26-12
Spring terminal	
-Wire gauge	0.14-2.5mm <sup>2</sup> (Not suitable for connecting terminal)
-AWG	26-14
Spring terminal(Quick-in)	
-Wire gauge	0.5-2.5mm <sup>2</sup>
-AWG	20-14
-Stripping length	10±0.5mm
-Contact resistance	$\leq 3m\Omega$

## Current carrying capacity

The current carrying is limited by maximum temperature of materials for inserts and contacts including terminals

Control and test procedures according to DIN EN 60512-5

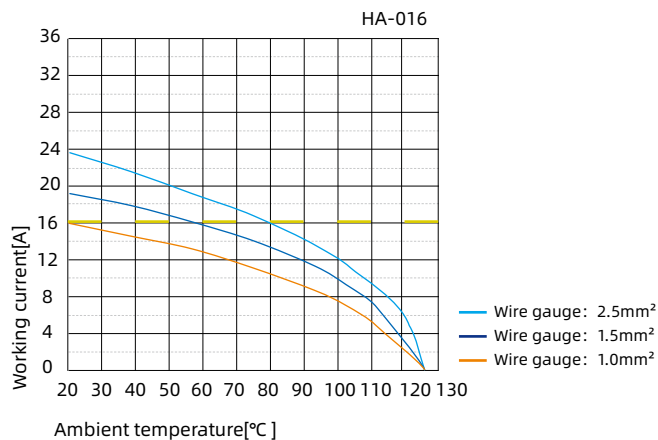
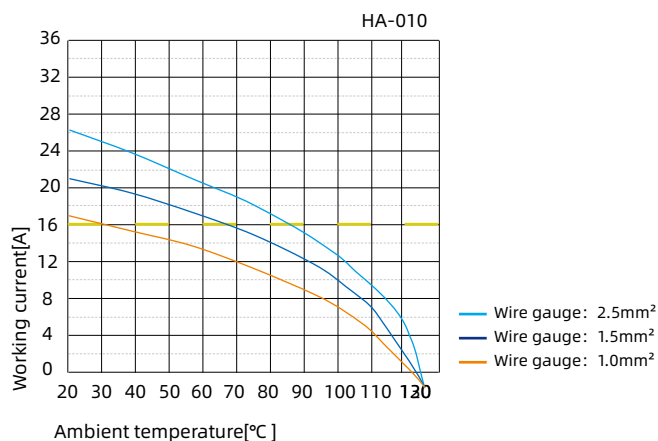
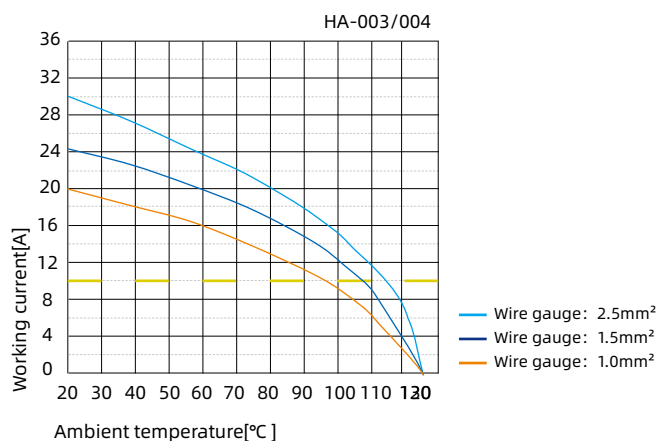

HA-003/004 The slim inserts

230/400V 10A 3/4+ ⊕



Inserts

Hoods/Housings: size 3A, please find the details on page 15-06-15-16.1.

Screw terminal



Insert	Designation	Order No.
Male	HA-003-M	121 003 011 0001
Female	HA-003-F	121 003 021 0001

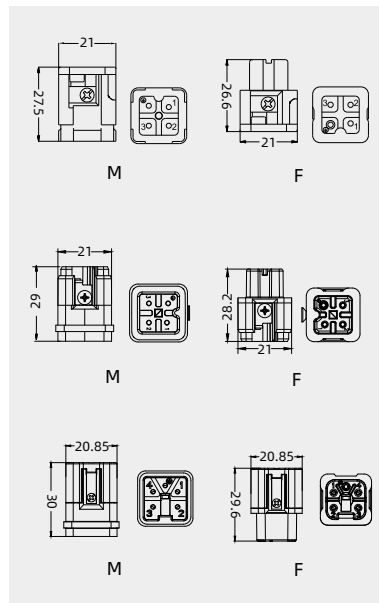

Male	HA-003-M-V2	121 003 011 0505
Female	HA-003-F-V2	121 003 021 0505

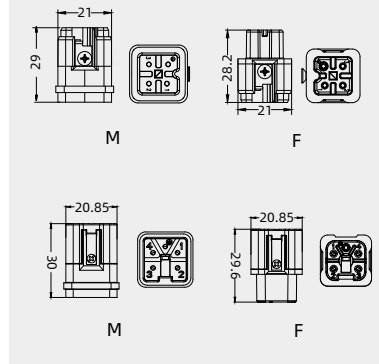

Male	HA-004-M-V2	121 004 011 0002
Female	HA-004-F-V2	121 004 021 0002

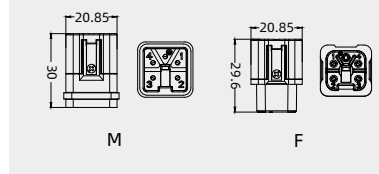

Coding element



Description	Designation	Order No.
coding, pokayoke	CODE-Q3	198 002 005 0034

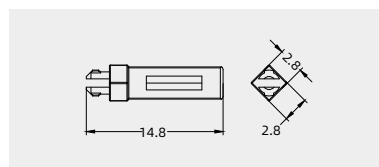

Suitable for HA-003-M/F-V2

Spring terminal, See P00-14 for the structural characteristics of spring.



Insert	Designation	Order No.
Male	HA-002-MS	121 002 012 0001
Female	HA-002-FS	121 002 022 0001

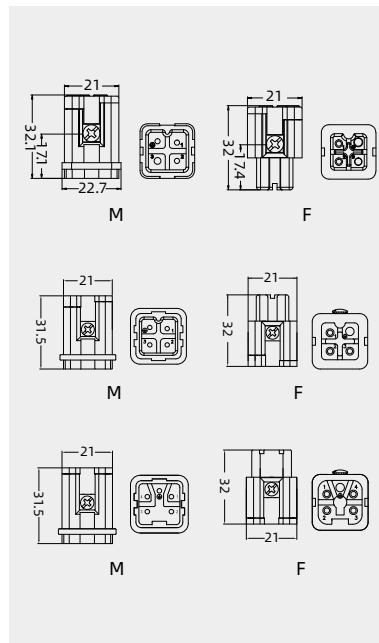

Male	HA-003-MS	121 003 012 0001
Female	HA-003-FS	121 003 022 0001

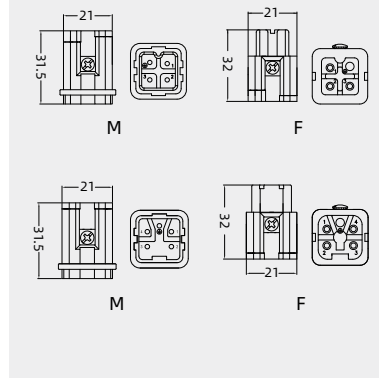

Male	HA-004-MS	121 004 012 0001
Female	HA-004-FS	121 004 022 0001

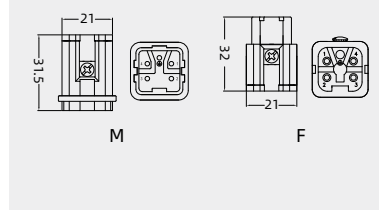

# HA-003/004 Quick-in module

230/400V 10A 3/4+ ⊕

## Inserts

Hoods/Housings: size 3A, please find the details on page 15-06-15-16.1.

### Spring terminal(Quick-in)



Insert	Designation	Order No.
Male	HA-003-MQ	121 003 001 0001
Female	HA-003-FQ	121 003 002 0001
Male	HA-004-MQ	121 004 001 0001
Female	HA-004-FQ	121 004 002 0001

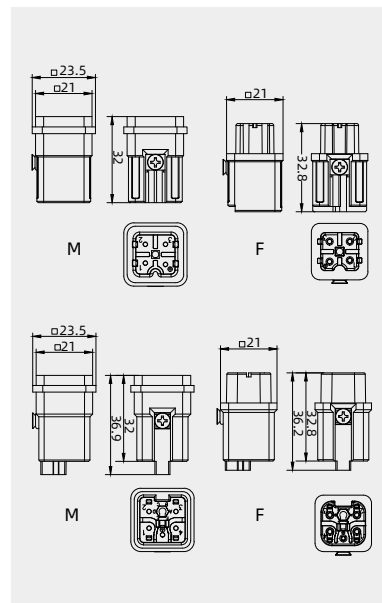

### Coding element



Description	Designation	Order No.
coding、pokayoke	CODE-Q3	198 002 005 0034

Suitable for HA-003-MQ/FQ

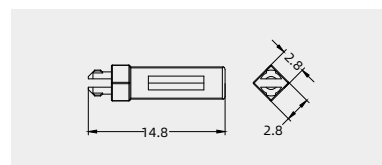

### Coding element



Description	Designation	Order No.
coding、pokayoke	CODE-Q5	198 002 005 0036

Suitable for HA-004-MQ/FQ

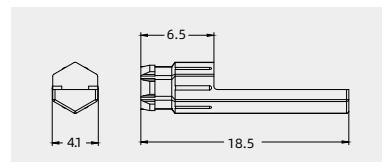

## HA-004-M-V2/HA-004-F-V2 Features

Step 1: wire from the top, lock the side screw

Step 2: close the cover

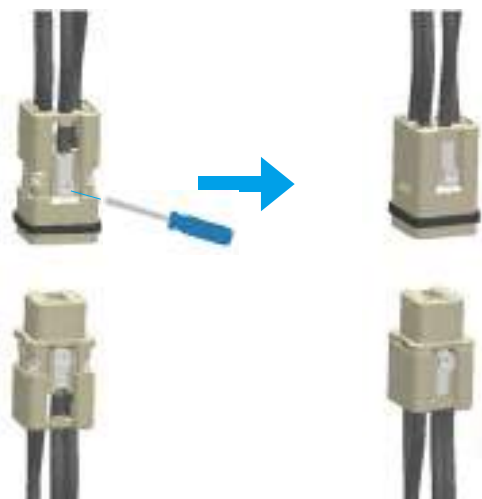

The feature of structure:

- ① .Cover was added;
- ② .Top entry, side screw locking
- ③ .Low insert height

The innovation:

- ① .The insert is separated from the shell by the cover. That ensures enough creepage distance and reliable electrical property;
- ② .When it is side entry, the cable have to be bent to an angle of 90 degree and go upward, the top entry could avoid the bend of cable and have convenient assembly
- ③ .Compact structure saves space.

# HA-010 The slim inserts

250V 16A 10+



## Inserts

Hoods/Housings: size 10A, please find the details on page 15-17~15-18.1.

### Screw terminal



Insert	Designation	Order No.
Male	HA-010-M	121 010 011 0001
Female	HA-010-F	121 010 021 0001
Male	HA-010-M/B <sup>1)</sup>	121 010 011 0503
Female	HA-010-F/B <sup>1)</sup>	121 010 021 0503

1) /B stands for wiring with cable protecting(details see page 00-09)

### Crimp terminal

Order crimp contacts separately



Insert	Designation	Order No.
Male	HA-010-MC	121 010 010 0001
Female	HA-010-FC	121 010 020 0001

Spring terminal, See P00-14 for the structural characteristics of spring.



Insert	Designation	Order No.
Male	HA-010-MS	121 010 012 0001
Female	HA-010-FS	121 010 022 0001

## Crimp contacts

### Crimp contacts 16A

Contact resistance ≤ 1mΩ silver plated



gold plated



More crimp contacts 16A see P13-04.

### Tools

Crimping tool



Contact removal tool



Male	Order No.	Female	Order No.
CESM-0.37	101 019 110 0301	CESF-0.37	101 019 120 0301
CESM-0.50	101 019 110 0401	CESF-0.50	101 019 120 0401
CESM-0.75	101 019 110 0601	CESF-0.75	101 019 120 0601
CESM-1.0	101 019 110 0801	CESF-1.0	101 019 120 0801
CESM-1.5	101 019 110 0901	CESF-1.5	101 019 120 0901
CESM-2.5	101 019 110 1001	CESF-2.5	101 019 120 1001
CESM-3.0	101 019 110 1101	CESF-3.0	101 019 120 1101
CESM-4.0	101 019 110 1201	CESF-4.0	101 019 120 1201
CEGM-0.37	101 019 210 0301	CEGF-0.37	101 019 220 0301
CEGM-0.50	101 019 210 0401	CEGF-0.50	101 019 220 0401
CEGM-0.75	101 019 210 0601	CEGF-0.75	101 019 220 0601
CEGM-1.0	101 019 210 0801	CEGF-1.0	101 019 220 0801
CEGM-1.5	101 019 210 0901	CEGF-1.5	101 019 220 0901
CEGM-2.5	101 019 210 1001	CEGF-2.5	101 019 220 1001
CEGM-3.0	101 019 210 1101	CEGF-3.0	101 019 220 1101
CEGM-4.0	101 019 210 1201	CEGF-4.0	101 019 220 1201

Wire gauge	Designation	Order No.
0.14-4mm <sup>2</sup>	TL02G	198 001 001 0011

Wire gauge: 0.14-0.37mm<sup>2</sup> please select TL02 Crimping tool.

Application	Designation	Order No.
for crimp contacts 16A	TL01	198 001 000 0002

More tools detail please find the page 32-03~32-06.

Notes: The tools for crimp terminal may influence the product quality and stability. Please select the tools recognized by our company.

1) Distance for contact max. 24 mm

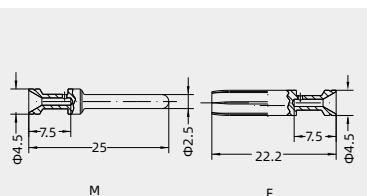
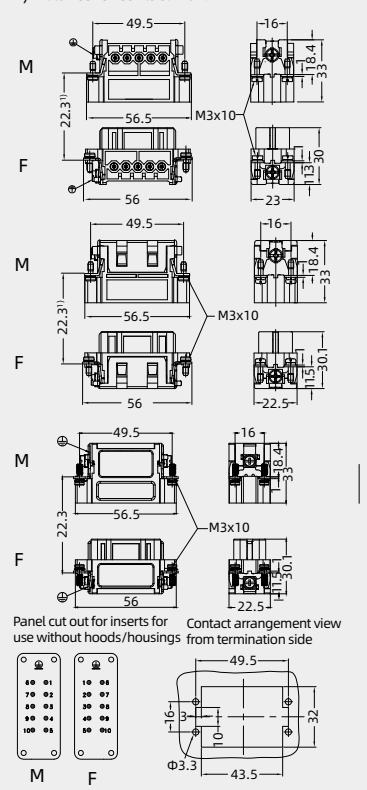

Identification	Wire gauge	Stripping length	
no groove	0.14-0.37 mm <sup>2</sup>	AWG 26-22	7.5mm
no groove	0.5 mm <sup>2</sup>	AWG 20	7.5mm
1 groove	0.75 mm <sup>2</sup>	AWG 18	7.5mm
1 groove	1 mm <sup>2</sup>	AWG 18	7.5mm
2 grooves	1.5 mm <sup>2</sup>	AWG 16	7.5mm
3 grooves	2.5 mm <sup>2</sup>	AWG 14	7.5mm
wide groove	3 mm <sup>2</sup>	AWG 12	7.5mm
no groove	4 mm <sup>2</sup>	AWG 12	7.5mm

When the wire gauge is less than 0.75mm<sup>2</sup>, it's better to use the auxiliary pin assembly tool TL15.



# HA-016 The slim inserts

250V 16A 16+



## Inserts

Hoods/Housings: size 16A, please find the details on page 15-19~15-20.

### Screw terminal



Insert	Designation	Order No.
Male	HA-016-M	121 016 011 0001
Female	HA-016-F	121 016 021 0001
Male	HA-016-M/B <sup>1)</sup>	121 016 011 0505
Female	HA-016-F/B <sup>1)</sup>	121 016 021 0505

1) /B stands for wiring with cable protecting(details see page 00-09)

### Crimp terminal

Order crimp contacts separately



Insert	Designation	Order No.
Male	HA-016-MC	121 016 010 0001
Female	HA-016-FC	121 016 020 0001

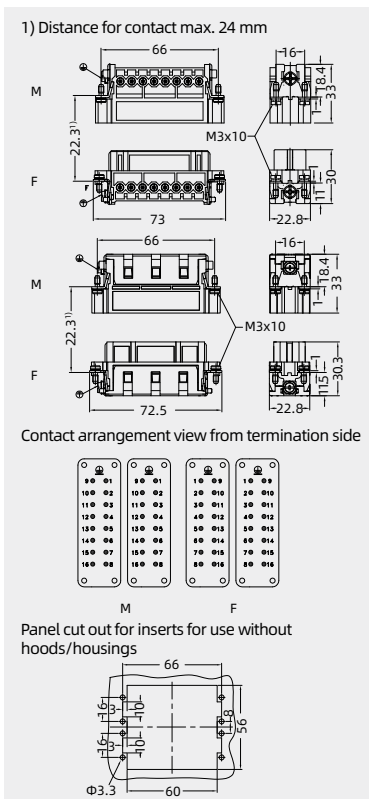

## Crimp contacts

### Crimp contacts 16A

Contact resistance ≤ 1mΩ  
silver plated



gold plated



More crimp contacts 16A see P13-04.

### Tools

Crimping tool



Contact removal tool



Male	Order No.	Female	Order No.
CESM-0.37	101 019 110 0301	CESF-0.37	101 019 120 0301
CESM-0.50	101 019 110 0401	CESF-0.50	101 019 120 0401
CESM-0.75	101 019 110 0601	CESF-0.75	101 019 120 0601
CESM-1.0	101 019 110 0801	CESF-1.0	101 019 120 0801
CESM-1.5	101 019 110 0901	CESF-1.5	101 019 120 0901
CESM-2.5	101 019 110 1001	CESF-2.5	101 019 120 1001
CESM-3.0	101 019 110 1101	CESF-3.0	101 019 120 1101
CESM-4.0	101 019 110 1201	CESF-4.0	101 019 120 1201
CEGM-0.37	101 019 210 0301	CEGF-0.37	101 019 220 0301
CEGM-0.50	101 019 210 0401	CEGF-0.50	101 019 220 0401
CEGM-0.75	101 019 210 0601	CEGF-0.75	101 019 220 0601
CEGM-1.0	101 019 210 0801	CEGF-1.0	101 019 220 0801
CEGM-1.5	101 019 210 0901	CEGF-1.5	101 019 220 0901
CEGM-2.5	101 019 210 1001	CEGF-2.5	101 019 220 1001
CEGM-3.0	101 019 210 1101	CEGF-3.0	101 019 220 1101
CEGM-4.0	101 019 210 1201	CEGF-4.0	101 019 220 1201

Wire gauge	Designation	Order No.
0.14-4mm <sup>2</sup>	TL02G	198 001 001 0011

Wire gauge: 0.14-0.37mm<sup>2</sup> please select TL02 Crimping tool.

Application	Designation	Order No.
for crimp contacts 16A	TL01	198 001 000 0002

More tools detail please find the page 32-03~32-06.

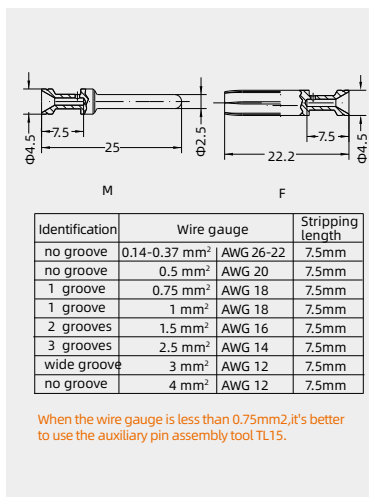

Notes: The tools for crimp terminal may influence the product quality and stability. Please select the tools recognized by our company.

HA-032 The slim inserts

250V 16A 32+



Inserts

Hoods/Housings: size 32A, please find the details on page 15-21~15-24.

Screw terminal



Insert	Designation	Order No.
Male	HA-016-M	121 016 011 0001
	HA-016-M(17-32)	121 016 011 0002
Female	HA-016-F	121 016 021 0001
	HA-016-F(17-32)	121 016 021 0002
Male	HA-016-M/B <sup>1)</sup>	121 016 011 0505
	HA-016-M/B(17-32) <sup>1)</sup>	121 016 011 0504
Female	HA-016-F/B <sup>1)</sup>	121 016 021 0505
	HA-016-F/B(17-32) <sup>1)</sup>	121 016 021 0504

1). /B stands for wiring with cable protecting (details see page 00-09)

Crimp terminal

Order crimp contacts separately



Insert	Designation	Order No.
Male	HA-016-MC	121 016 010 0001
	HA-016-MC(17-32)	121 016 010 0002
Female	HA-016-FC	121 016 020 0001
	HA-016-FC(17-32)	121 016 020 0002

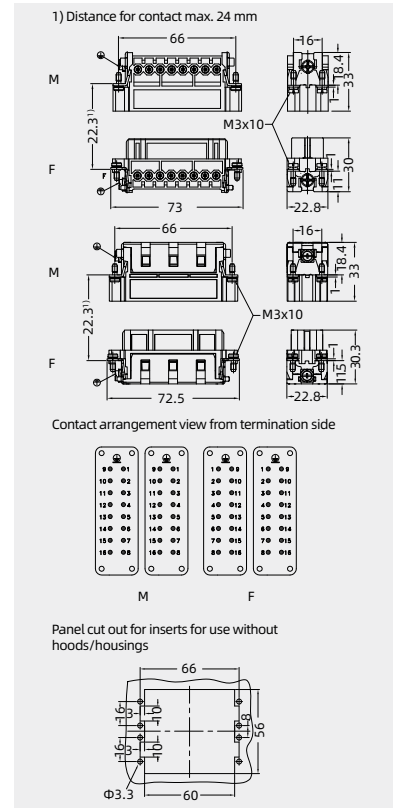

Crimp contacts

Crimp contacts 16A

Contact resistance ≤ 1mΩ silver plated



gold plated



Male	Order No.	Female	Order No.
CESM-0.37	101 019 110 0301	CESF-0.37	101 019 120 0301
CESM-0.50	101 019 110 0401	CESF-0.50	101 019 120 0401
CESM-0.75	101 019 110 0601	CESF-0.75	101 019 120 0601
CESM-1.0	101 019 110 0801	CESF-1.0	101 019 120 0801
CESM-1.5	101 019 110 0901	CESF-1.5	101 019 120 0901
CESM-2.5	101 019 110 1001	CESF-2.5	101 019 120 1001
CESM-3.0	101 019 110 1101	CESF-3.0	101 019 120 1101
CESM-4.0	101 019 110 1201	CESF-4.0	101 019 120 1201
CEGM-0.37	101 019 210 0301	CEGF-0.37	101 019 220 0301
CEGM-0.50	101 019 210 0401	CEGF-0.50	101 019 220 0401
CEGM-0.75	101 019 210 0601	CEGF-0.75	101 019 220 0601
CEGM-1.0	101 019 210 0801	CEGF-1.0	101 019 220 0801
CEGM-1.5	101 019 210 0901	CEGF-1.5	101 019 220 0901
CEGM-2.5	101 019 210 1001	CEGF-2.5	101 019 220 1001
CEGM-3.0	101 019 210 1101	CEGF-3.0	101 019 220 1101
CEGM-4.0	101 019 210 1201	CEGF-4.0	101 019 220 1201

More crimp contacts 16A see P13-04.

Tools

Crimping tool



Contact removal tool



Wire gauge	Designation	Order No.
0.14-4mm <sup>2</sup>	TL02G	198 001 001 0011
Wire gauge: 0.14-0.37mm <sup>2</sup> please select TL02 Crimping tool.		
Application	Designation	Order No.
for crimp contacts 16A	TL01	198 001 000 0002

More tools detail please find the page 32-03~32-06.

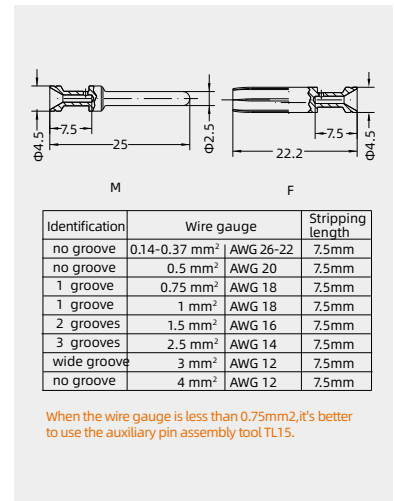

Notes: The tools for crimp terminal may influence the product quality and stability. Please select the tools recognized by our company.

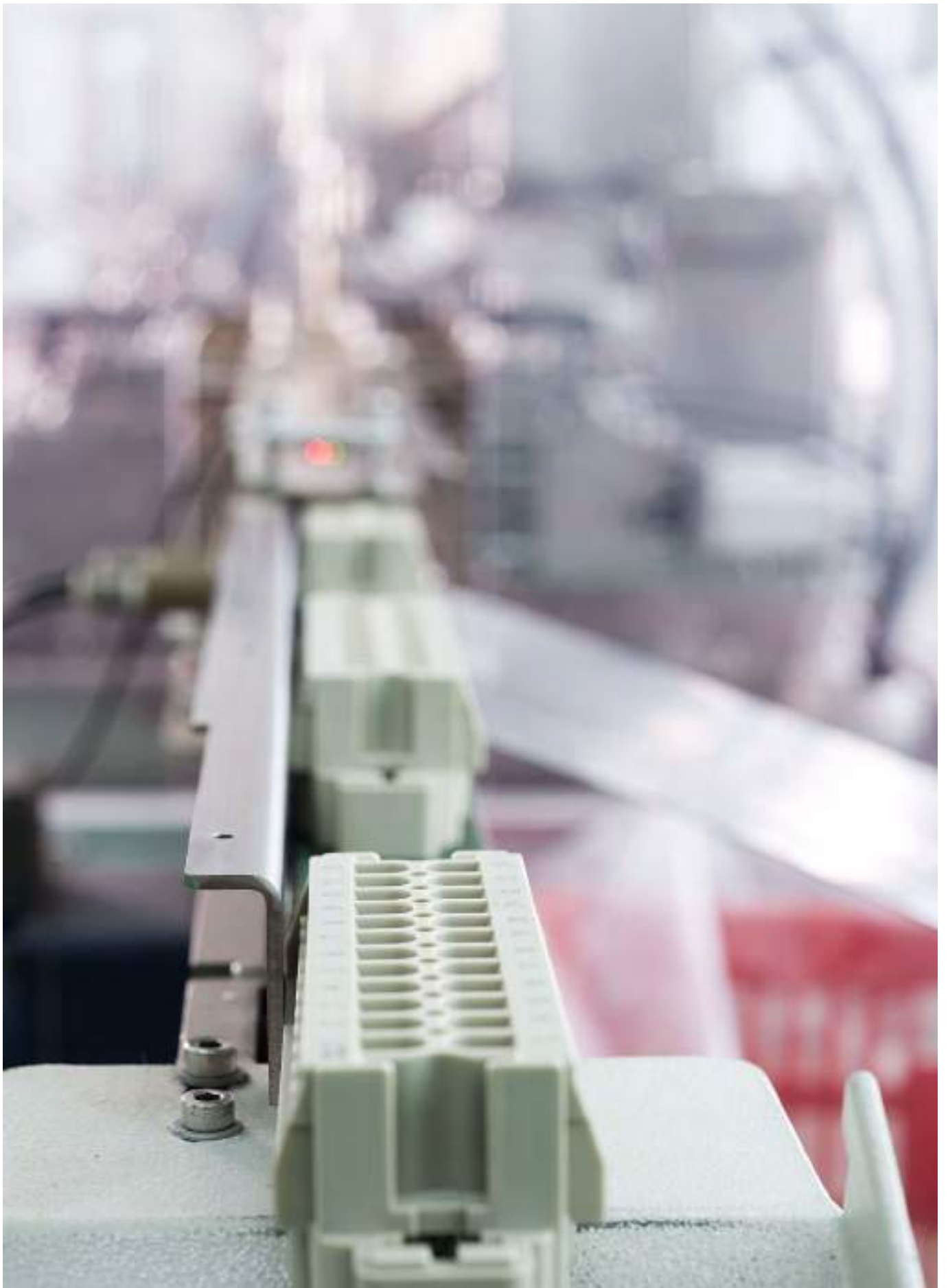



## HE SERIES

Standard products

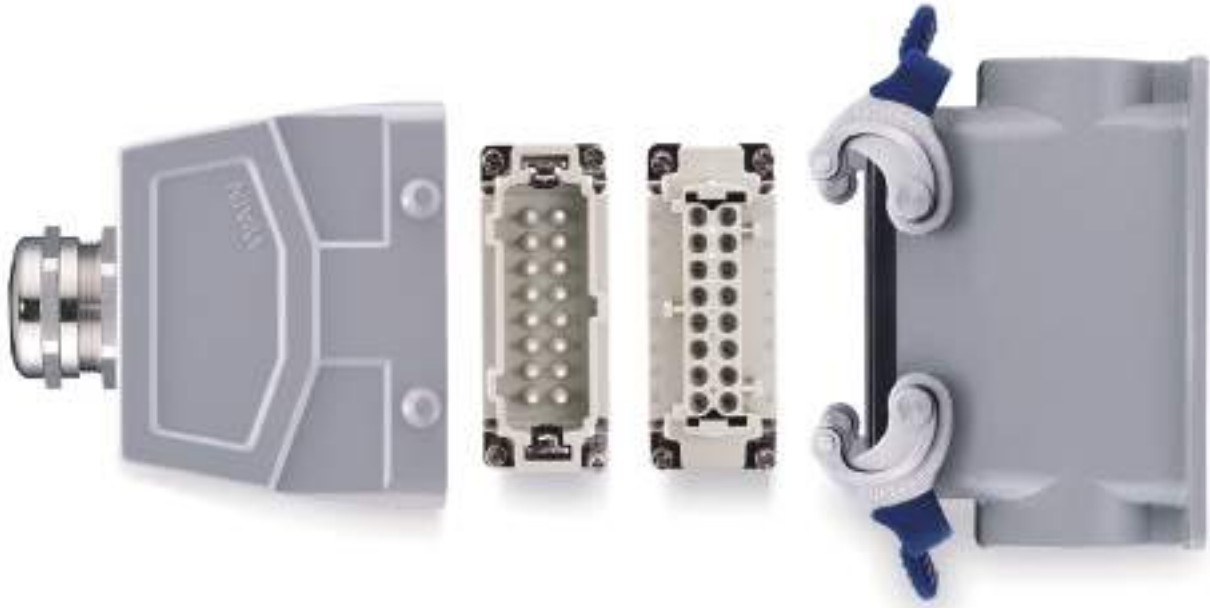

# HE SERIES Standard inserts

## Technical characteristics

Specifications	DIN EN 60 664 DIN EN 61 984
Approvals	
Inserts	
Electrical data acc. to EN 61 984	
-Rated current	16A
-Rated voltage	500V
-Rated impulse voltage	6kV
-Pollution degree	3
-Pollution degree 2 also	16A 400/690V 6kV 2
Rated voltage acc. to UL	600V
Insulation resistance	$\geq 10^{10}\Omega$
Material	polycarbonate
Limiting temperatures	-40°C ... +125°C
Flammability acc. to UL 94	V0
Mechanical working life(mating cycles)	$\geq 500$
Contacts	
Material	copper alloy
Surface	hard-gold plated hard-silver plated
Contact resistance	$\leq 1m\Omega$
Screw terminal	
-Wire gauge	0.75-2.5mm <sup>2</sup>
-AWG	18-14
-Tightening/Test torque	0.5Nm
-Stripping length	7.0mm
Crimp terminal	
-Wire gauge	0.14-4.0mm <sup>2</sup>
-AWG	26-12
-Stripping length	7.5mm
Spring terminal	
-Wire gauge	0.14-2.5mm <sup>2</sup>
-AWG	26-14
-Stripping length	7-9mm
Spring terminal(Quick-in)	
-Wire gauge	0.5-2.5mm <sup>2</sup>
-AWG	20-14
-Stripping length	9-10mm
-Contact resistance	$\leq 3m\Omega$

## Current carrying capacity

The current carrying is limited by maximum temperature of materials for inserts and contacts including terminals

Control and test procedures according to DIN EN 60512-5

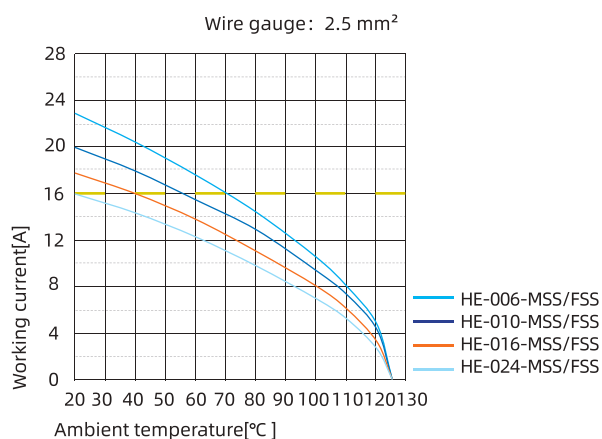
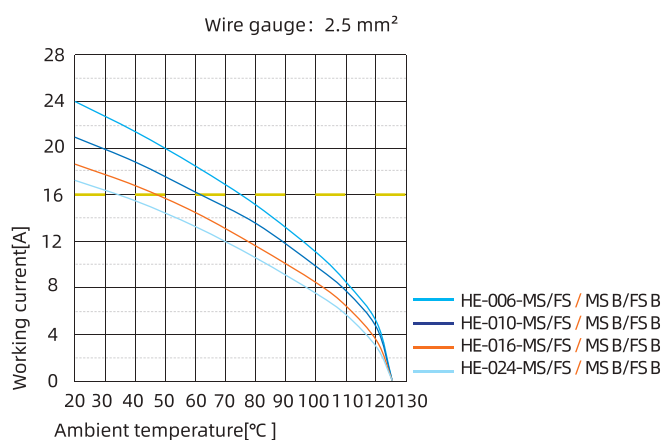
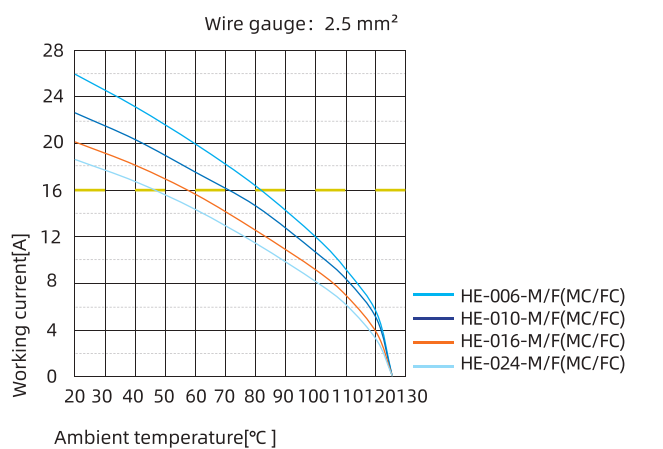

HE-006 Standard inserts

500V 16A 6+



Inserts

Hoods/Housings: size 6B, please find the details on page 15-25~15-38.2.

Screw terminal



Insert	Designation	Order No.
Male	HE-006-M	122 006 011 0001
Female	HE-006-F	122 006 021 0001

Crimp terminal

Order crimp contacts separately



Insert	Designation	Order No.
Male	HE-006-MC <sup>1)</sup>	122 006 010 0001
Female	HE-006-FC <sup>1)</sup>	122 006 020 0001

1).can match PCB adapter,see page 14-04-14-05.

Male	HE-006-MC/N <sup>2)</sup>	122 006 010 0101
Female	HE-006-FC/N <sup>2)</sup>	122 006 020 0101

2).for crimp contacts 16A-Enhanced III ,see page 13-04.

Spring terminal, See P00-14 for the structural characteristics of spring.



Insert	Designation	Order No.
Male	HE-006-MS	122 006 012 0001
Female	HE-006-FS	122 006 022 0001

Male	HE-006-MS B	122 006 012 0101
Female	HE-006-FS B	122 006 022 0101

Double spring connection(Two terminal per contact)  
Only suitable for high structure shells

Male	HE-006-MSS	122 006 012 0201
Female	HE-006-FSS	122 006 022 0201

1) Distance for contact max. 21 mm

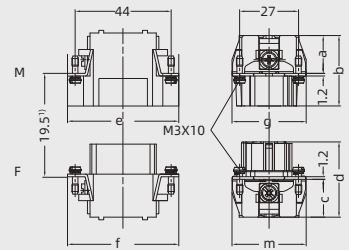

	a	b	e	g	c	d	f	m
M/F	16	32.4	51	34	16.8	34.5	50.5	34
MC/FC	18	33	51	34	18	35	50.5	34
MC/N / FC/N	18.3	34	51	34	19	36	51	34
MS/FS	18	33.3	51	34	18.2	35.4	50.5	34
MSS/FSS	34.5	49.5	50	34	33.4	50	50	34
MS B / FS B	19.5	34.7	51	34	19	36.5	51	34

Contact arrangement view from termination side

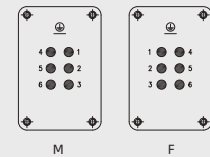

Panel cut out for inserts for use without hoods/housings

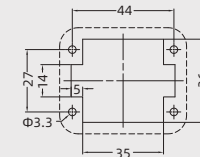

Crimp contacts

Crimp contacts 16A

Contact resistance ≤ 1mΩ  
silver plated



gold plated



More crimp contacts 16A see P13-04.

Tools

Crimping tool



Contact removal tool



Male	Order No.	Female	Order No.
CESM-0.37	101 019 110 0301	CESF-0.37	101 019 120 0301
CESM-0.50	101 019 110 0401	CESF-0.50	101 019 120 0401
CESM-0.75	101 019 110 0601	CESF-0.75	101 019 120 0601
CESM-1.0	101 019 110 0801	CESF-1.0	101 019 120 0801
CESM-1.5	101 019 110 0901	CESF-1.5	101 019 120 0901
CESM-2.5	101 019 110 1001	CESF-2.5	101 019 120 1001
CESM-3.0	101 019 110 1101	CESF-3.0	101 019 120 1101
CESM-4.0	101 019 110 1201	CESF-4.0	101 019 120 1201

CEGM-0.37	101 019 210 0301	CEGF-0.37	101 019 220 0301
CEGM-0.50	101 019 210 0401	CEGF-0.50	101 019 220 0401
CEGM-0.75	101 019 210 0601	CEGF-0.75	101 019 220 0601
CEGM-1.0	101 019 210 0801	CEGF-1.0	101 019 220 0801
CEGM-1.5	101 019 210 0901	CEGF-1.5	101 019 220 0901
CEGM-2.5	101 019 210 1001	CEGF-2.5	101 019 220 1001
CEGM-3.0	101 019 210 1101	CEGF-3.0	101 019 220 1101
CEGM-4.0	101 019 210 1201	CEGF-4.0	101 019 220 1201

Wire gauge	Designation	Order No.
0.14-4mm <sup>2</sup>	TL02G	198 001 001 0011

Wire gauge: 0.14-0.37mm<sup>2</sup> please select TL02 Crimping tool.

Application	Designation	Order No.
for crimp contacts 16A	TL01	198 001 000 0002

More tools detail please find the page 32-03-32-06.

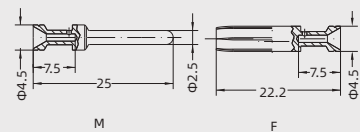

Identification	Wire gauge	Stripping length
no groove	0.14-0.37 mm <sup>2</sup>	AWG 26-22
no groove	0.5 mm <sup>2</sup>	AWG 20
1 groove	0.75 mm <sup>2</sup>	AWG 18
1 groove	1 mm <sup>2</sup>	AWG 18
2 grooves	1.5 mm <sup>2</sup>	AWG 16
3 grooves	2.5 mm <sup>2</sup>	AWG 14
wide groove	3 mm <sup>2</sup>	AWG 12
no groove	4 mm <sup>2</sup>	AWG 12

When the wire gauge is less than 0.75mm<sup>2</sup>, it's better to use the auxiliary pin assembly tool TL15.

Notes: The tools for crimp terminal may influence the product quality and stability. Please select the tools recognized by our company.

HE-006 Quick-in module

500V 16A 6+ 

Inserts



Hoods/Housings: size 6B, please find the details on page 15-25~15-38.2.

Spring terminal(Quick-in)

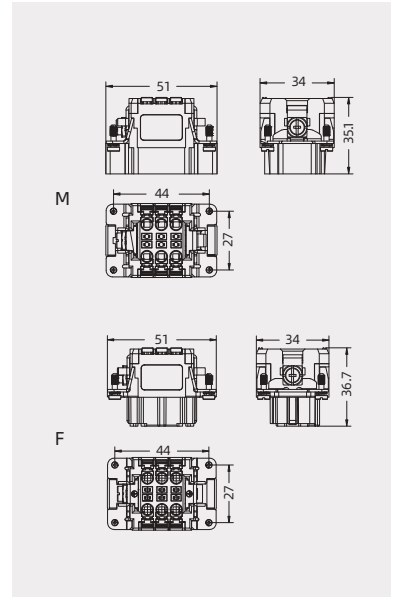
Insert	Designation	Order No.
Male	HE-006-MQ P	122 000 099 0500
Female	HE-006-FQ P	122 000 099 0501



Bridging module

Description	Designation	Order No.
	HEB/P-2T1	198 002 007 0029
	HEB/P-1T3	198 002 007 0028
	HEB/P-1T2	198 002 007 0027

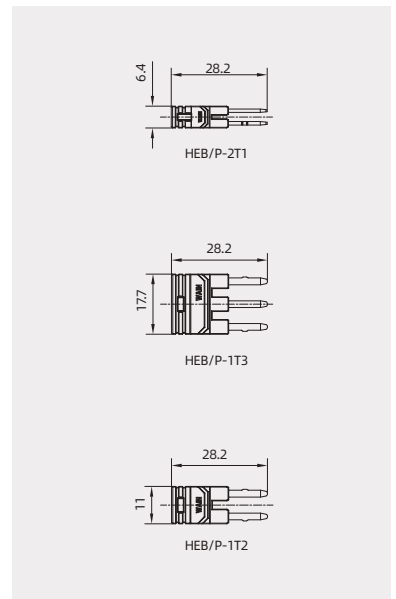

Bridging module



Description	Designation	Order No.
	HEB/P-1T4	198 002 007 0033

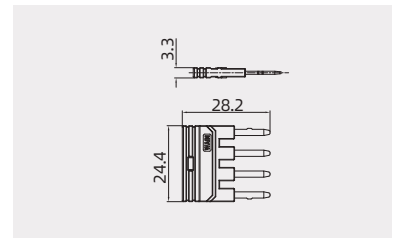



HE-010 Standard inserts

500V 16A 10+



Inserts

Hoods/Housings: size 10B, please find the details on page 15-39~15-69.

Screw terminal



Insert	Designation	Order No.
Male	HE-010-M	122 010 011 0001
Female	HE-010-F	122 010 021 0001

Crimp terminal

Order crimp contacts separately



Insert	Designation	Order No.
Male	HE-010-MC <sup>1)</sup>	122 010 010 0001
Female	HE-010-FC <sup>1)</sup>	122 010 020 0001

<sup>1)</sup>can match PCB adapter,see page 14-04~14-05.

Spring terminal, See P00-14 for the structural characteristics of spring.



Insert	Designation	Order No.
Male	HE-010-MS	122 010 012 0001
Female	HE-010-FS	122 010 022 0001
Male	HE-010-MS B	122 010 012 0101
Female	HE-010-FS B	122 010 022 0101
Double spring connection(Two terminal per contact) Only suitable for high structure shells		
Male	HE-010-MSS	122 010 012 0201
Female	HE-010-FSS	122 010 022 0201

1) Distance for contact max. 21 mm

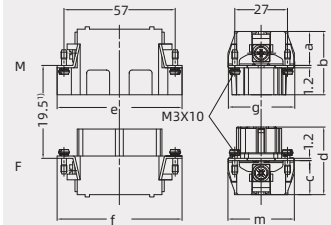

	a	b	e	g	c	d	f	m
M/F	16.5	32	64.5	34	16.8	34.2	64	34
MC/FC	18	33	64	34	17.5	35.2	64	34
MS/FS	18.5	33.5	64	34	18.5	35.6	64	34
MSS/FSS	34	49	64	34	33.5	49.5	63	34
MS B / FS B	19	34.5	64	34	18.6	36	64	34

Contact arrangement view from termination side

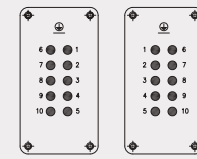

Panel cut out for inserts for use without hoods/housings

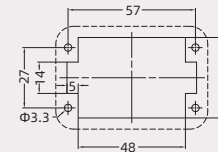

Crimp contacts

Crimp contacts 16A

Contact resistance ≤ 1mΩ  
silver plated



gold plated



Male	Order No.	Female	Order No.
CESM-0.37	101 019 110 0301	CESF-0.37	101 019 120 0301
CESM-0.50	101 019 110 0401	CESF-0.50	101 019 120 0401
CESM-0.75	101 019 110 0601	CESF-0.75	101 019 120 0601
CESM-1.0	101 019 110 0801	CESF-1.0	101 019 120 0801
CESM-1.5	101 019 110 0901	CESF-1.5	101 019 120 0901
CESM-2.5	101 019 110 1001	CESF-2.5	101 019 120 1001
CESM-3.0	101 019 110 1101	CESF-3.0	101 019 120 1101
CESM-4.0	101 019 110 1201	CESF-4.0	101 019 120 1201
CEGM-0.37	101 019 210 0301	CEGF-0.37	101 019 220 0301
CEGM-0.50	101 019 210 0401	CEGF-0.50	101 019 220 0401
CEGM-0.75	101 019 210 0601	CEGF-0.75	101 019 220 0601
CEGM-1.0	101 019 210 0801	CEGF-1.0	101 019 220 0801
CEGM-1.5	101 019 210 0901	CEGF-1.5	101 019 220 0901
CEGM-2.5	101 019 210 1001	CEGF-2.5	101 019 220 1001
CEGM-3.0	101 019 210 1101	CEGF-3.0	101 019 220 1101
CEGM-4.0	101 019 210 1201	CEGF-4.0	101 019 220 1201

More crimp contacts 16A see P13-04.

Tools

Crimping tool



Wire gauge	Designation	Order No.
0.14-4mm <sup>2</sup>	TL02G	198 001 001 0011

Wire gauge: 0.14-0.37mm<sup>2</sup> please select TL02 Crimping tool.

Contact removal tool



Application	Designation	Order No.
for crimp contacts 16A	TL01	198 001 000 0002

More tools detail please find the page 32-03-32-06.

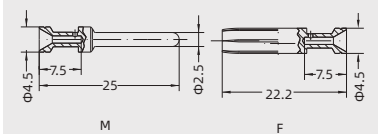

Identification	Wire gauge	Stripping length	
no groove	0.14-0.37 mm <sup>2</sup>	AWG 26-22	7.5mm
no groove	0.5 mm <sup>2</sup>	AWG 20	7.5mm
1 groove	0.75 mm <sup>2</sup>	AWG 18	7.5mm
1 groove	1 mm <sup>2</sup>	AWG 18	7.5mm
2 grooves	1.5 mm <sup>2</sup>	AWG 16	7.5mm
3 grooves	2.5 mm <sup>2</sup>	AWG 14	7.5mm
wide groove	3 mm <sup>2</sup>	AWG 12	7.5mm
no groove	4 mm <sup>2</sup>	AWG 12	7.5mm

When the wire gauge is less than 0.75mm<sup>2</sup>, it's better to use the auxiliary pin assembly tool TL15.

Notes: The tools for crimp terminal may influence the product quality and stability. Please select the tools recognized by our company.

HE-010 Quick-in module

500V 16A 10+ 

Inserts



Hoods/Housings: size 10B , please find the details on page 15-39~15-69.

Spring terminal(Quick-in)

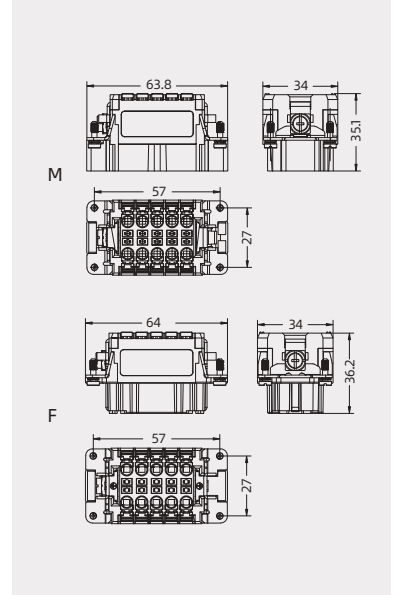
Insert	Designation	Order No.
Male	HE-010-MQ P	122 000 099 0502
Female	HE-010-FQ P	122 000 099 0503



Bridging module

Description	Designation	Order No.
	HEB/P-2T1	198 002 007 0029
	HEB/P-1T3	198 002 007 0028
	HEB/P-1T2	198 002 007 0027

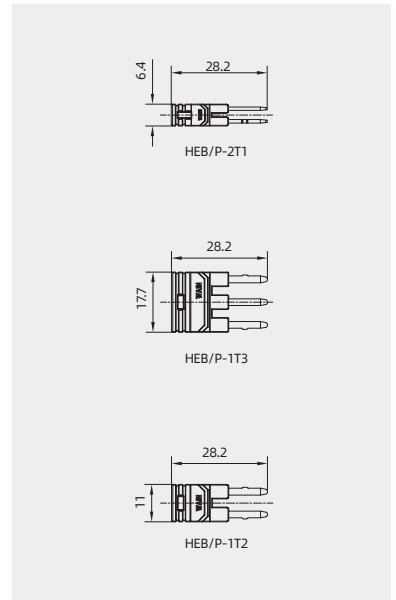

Bridging module



Description	Designation	Order No.
	HEB/P-1T4	198 002 007 0033

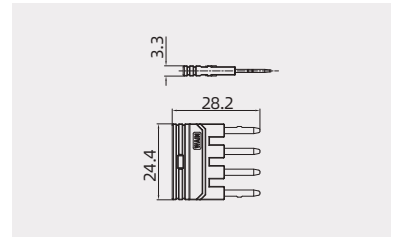

HE-016 Standard inserts

500V 16A 16+



Inserts

Hoods/Housings: size 16B, please find the details on page 15-70~15-107.1.

Screw terminal



Insert	Designation	Order No.
Male	HE-016-M	122 016 011 0001
Female	HE-016-F	122 016 021 0001

Crimp terminal

Order crimp contacts separately



Insert	Designation	Order No.
Male	HE-016-MC <sup>1)</sup>	122 016 010 0001
Female	HE-016-FC <sup>1)</sup>	122 016 020 0001

<sup>1)</sup>can match PCB adapter,see page 14-04~14-05.

Spring terminal, See P00-14 for the structural characteristics of spring.



Insert	Designation	Order No.
Male	HE-016-MS	122 016 012 0001
Female	HE-016-FS	122 016 022 0001

Male	HE-016-MS B	122 016 012 0101
Female	HE-016-FS B	122 016 022 0101

Double spring connection(Two terminal per contact)  
Only suitable for high structure shells

Male	HE-016-MSS	122 016 012 0201
Female	HE-016-FSS	122 016 022 0201

1) Distance for contact max. 21 mm

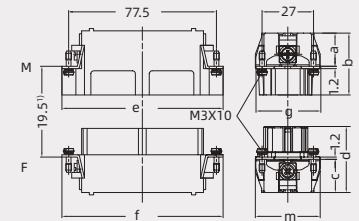

	a	b	e	g	c	d	f	m
M/F	17	32.5	84.2	34	17	34.5	84.2	33.5
MC/FC	18	33.5	84.5	34	18	35	84.5	34
MS/FS	18	33.7	84.5	34	18.2	35.5	84.5	34
MSS/FSS	34.3	49	84.5	34	32.2	49	84.5	34
MS B / FS B	19.6	34.7	84.3	34	18.6	36	84.5	34

Contact arrangement view from termination side

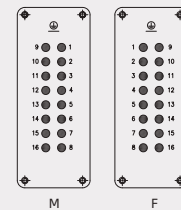

Panel cut out for inserts for use without hoods/housings

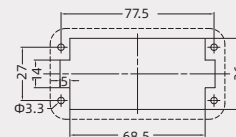

Crimp contacts

Crimp contacts 16A

Contact resistance ≤ 1mΩ  
silver plated



gold plated



More crimp contacts 16A see P13-04.

Tools

Crimping tool



Contact removal tool



Male	Order No.	Female	Order No.
CESM-0.37	101 019 110 0301	CESF-0.37	101 019 120 0301
CESM-0.50	101 019 110 0401	CESF-0.50	101 019 120 0401
CESM-0.75	101 019 110 0601	CESF-0.75	101 019 120 0601
CESM-1.0	101 019 110 0801	CESF-1.0	101 019 120 0801
CESM-1.5	101 019 110 0901	CESF-1.5	101 019 120 0901
CESM-2.5	101 019 110 1001	CESF-2.5	101 019 120 1001
CESM-3.0	101 019 110 1101	CESF-3.0	101 019 120 1101
CESM-4.0	101 019 110 1201	CESF-4.0	101 019 120 1201

CEGM-0.37	101 019 210 0301	CEGF-0.37	101 019 220 0301
CEGM-0.50	101 019 210 0401	CEGF-0.50	101 019 220 0401
CEGM-0.75	101 019 210 0601	CEGF-0.75	101 019 220 0601
CEGM-1.0	101 019 210 0801	CEGF-1.0	101 019 220 0801
CEGM-1.5	101 019 210 0901	CEGF-1.5	101 019 220 0901
CEGM-2.5	101 019 210 1001	CEGF-2.5	101 019 220 1001
CEGM-3.0	101 019 210 1101	CEGF-3.0	101 019 220 1101
CEGM-4.0	101 019 210 1201	CEGF-4.0	101 019 220 1201

Wire gauge	Designation	Order No.
0.14-4mm <sup>2</sup>	TL02G	198 001 001 0011

Wire gauge: 0.14-0.37mm<sup>2</sup> please select TL02 Crimping tool.

Application	Designation	Order No.
for crimp contacts 16A	TL01	198 001 000 0002

More tools detail please find the page 32-03-32-06.

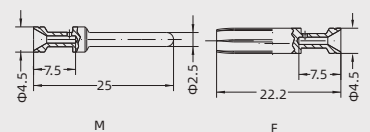

Identification	Wire gauge	Stripping length
no groove	0.14-0.37 mm <sup>2</sup>	AWG 26-22
no groove	0.5 mm <sup>2</sup>	AWG 20
1 groove	0.75 mm <sup>2</sup>	AWG 18
1 groove	1 mm <sup>2</sup>	AWG 18
2 grooves	1.5 mm <sup>2</sup>	AWG 16
3 grooves	2.5 mm <sup>2</sup>	AWG 14
wide groove	3 mm <sup>2</sup>	AWG 12
no groove	4 mm <sup>2</sup>	AWG 12

When the wire gauge is less than 0.75mm<sup>2</sup>, it's better to use the auxiliary pin assembly tool TL15.

Notes: The tools for crimp terminal may influence the product quality and stability. Please select the tools recognized by our company.

HE-016 Quick-in module

500V 16A 16+ 

Inserts

Hoods/Housings: size 16B, please find the details on page 15-70~15-1071.

Spring terminal(Quick-in)



Insert	Designation	Order No.
Male	HE-016-MQ P	122 000 099 0504
Female	HE-016-FQ P	122 000 099 0505

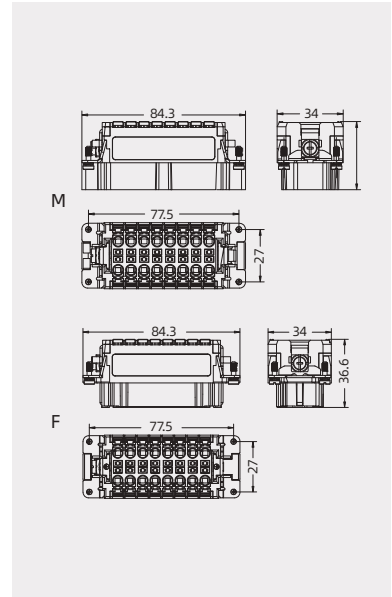

Bridging module



Description	Designation	Order No.
	HEB/P-2T1	198 002 007 0029
	HEB/P-1T3	198 002 007 0028
	HEB/P-1T2	198 002 007 0027

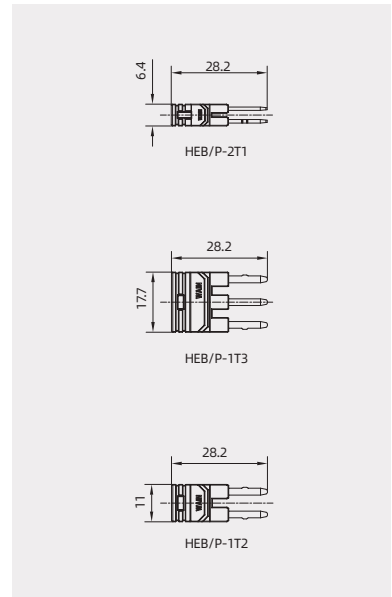

Bridging module



Description	Designation	Order No.
	HEB/P-1T4	198 002 007 0033

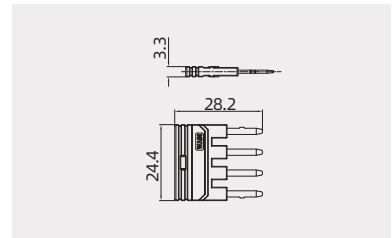

HE-024 Standard inserts

500V 16A 24+



Inserts

Hoods/Housings: size 24B, please find the details on page 15-108~15-150.

Screw terminal



Insert	Designation	Order No.
Male	HE-024-M	122 024 011 0001
Female	HE-024-F	122 024 021 0001

Crimp terminal

Order crimp contacts separately



Insert	Designation	Order No.
Male	HE-024-MC <sup>1)</sup>	122 024 010 0001
Female	HE-024-FC <sup>1)</sup>	122 024 020 0001

<sup>1)</sup>can match PCB adapter,see page 14-04~14-05.

Spring terminal, See P00-14 for the structural characteristics of spring.



Insert	Designation	Order No.
Male	HE-024-MS	122 024 012 0001
Female	HE-024-FS	122 024 022 0001

Male	HE-024-MS B	122 024 012 0101
Female	HE-024-FS B	122 024 022 0101

Double spring connection(Two terminal per contact)  
Only suitable for high structure shells

Male	HE-024-MSS	122 024 012 0201
Female	HE-024-FSS	122 024 022 0201

1) Distance for contact max. 21 mm

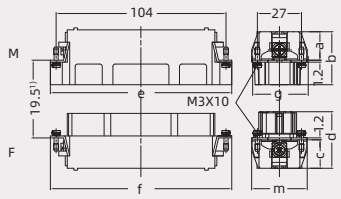

	a	b	e	g	c	d	f	m
M/F	17	32.5	111	33.5	17	34.5	111	33.5
MC/FC	18.3	33.5	111	34	18.3	35.5	111	34
MS/FS	18.5	33.6	111	34	18.5	35.6	111	34
MSS/FSS	34	49	110	34	32	49	110	34
MS B / FS B	19.6	34.7	111	34	19	36.2	111	34

Contact arrangement view from termination side

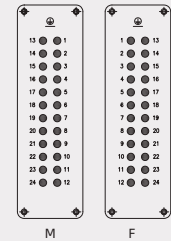

Panel cut out for inserts for use without hoods/housings

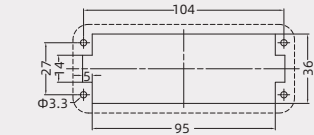

Crimp contacts

Crimp contacts 16A

Contact resistance ≤ 1mΩ  
silver plated



gold plated



More crimp contacts 16A see P13-04.

Tools

Crimping tool

Contact removal tool



Male	Order No.	Female	Order No.
CESM-0.37	101 019 110 0301	CESF-0.37	101 019 120 0301
CESM-0.50	101 019 110 0401	CESF-0.50	101 019 120 0401
CESM-0.75	101 019 110 0601	CESF-0.75	101 019 120 0601
CESM-1.0	101 019 110 0801	CESF-1.0	101 019 120 0801
CESM-1.5	101 019 110 0901	CESF-1.5	101 019 120 0901
CESM-2.5	101 019 110 1001	CESF-2.5	101 019 120 1001
CESM-3.0	101 019 110 1101	CESF-3.0	101 019 120 1101
CESM-4.0	101 019 110 1201	CESF-4.0	101 019 120 1201

CEGM-0.37	101 019 210 0301	CEGF-0.37	101 019 220 0301
CEGM-0.50	101 019 210 0401	CEGF-0.50	101 019 220 0401
CEGM-0.75	101 019 210 0601	CEGF-0.75	101 019 220 0601
CEGM-1.0	101 019 210 0801	CEGF-1.0	101 019 220 0801
CEGM-1.5	101 019 210 0901	CEGF-1.5	101 019 220 0901
CEGM-2.5	101 019 210 1001	CEGF-2.5	101 019 220 1001
CEGM-3.0	101 019 210 1101	CEGF-3.0	101 019 220 1101
CEGM-4.0	101 019 210 1201	CEGF-4.0	101 019 220 1201

Wire gauge	Designation	Order No.
0.14-4mm <sup>2</sup>	TL02G	198 001 001 0011

Wire gauge: 0.14-0.37mm<sup>2</sup> please select TL02 Crimping tool.

Application	Designation	Order No.
for crimp contacts 16A	TL01	198 001 000 0002

More tools detail please find the page 32-03-32-06.

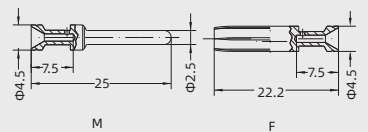

Identification	Wire gauge	Stripping length	
no groove	0.14-0.37 mm <sup>2</sup>	AWG 26-22	7.5mm
no groove	0.5 mm <sup>2</sup>	AWG 20	7.5mm
1 groove	0.75 mm <sup>2</sup>	AWG 18	7.5mm
1 groove	1 mm <sup>2</sup>	AWG 18	7.5mm
2 grooves	1.5 mm <sup>2</sup>	AWG 16	7.5mm
3 grooves	2.5 mm <sup>2</sup>	AWG 14	7.5mm
wide groove	3 mm <sup>2</sup>	AWG 12	7.5mm
no groove	4 mm <sup>2</sup>	AWG 12	7.5mm

When the wire gauge is less than 0.75mm<sup>2</sup>, it's better to use the auxiliary pin assembly tool TL15.

Notes: The tools for crimp terminal may influence the product quality and stability. Please select the tools recognized by our company.

HE-024 Quick-in module

500V 16A 24+ 

Inserts

Hoods/Housings: size 24B, please find the details on page 15-108~15-150.

Spring terminal(Quick-in)

Insert	Designation	Order No.
Male	HE-024-MQ P	122 024 010 0003
Female	HE-024-FQ P	122 024 020 0003

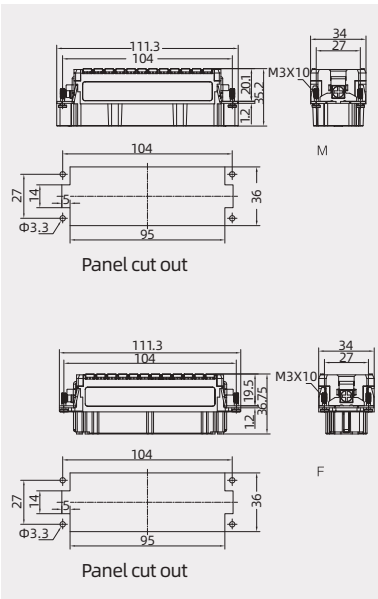

Bridging module

Description	Designation	Order No.
	HEB/P-2T1	198 002 007 0029
	HEB/P-1T3	198 002 007 0028
	HEB/P-1T2	198 002 007 0027

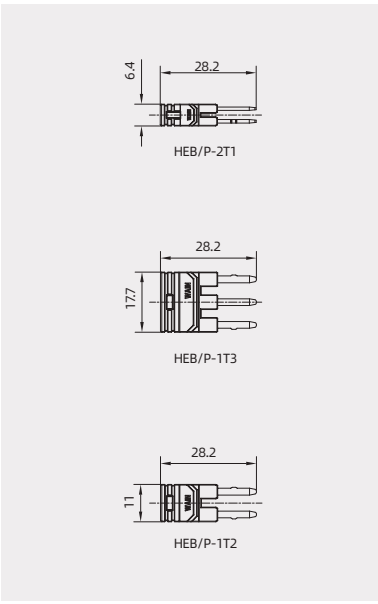

Bridging module 

Description	Designation	Order No.
	HEB/P-1T4	198 002 007 0033

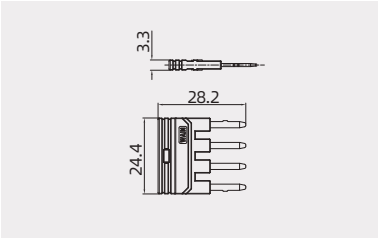

HE-032 Standard inserts

500V 16A 32+



Inserts

Hoods/Housings: size 32B, please find the details on page 15-151~15-159.

Screw terminal



Insert	Designation	Order No.
Male	HE-016-M	122 016 011 0001
	HE-016-M(17-32)	122 016 011 0002
Female	HE-016-F	122 016 021 0001
	HE-016-F(17-32)	122 016 021 0002

Crimp terminal

Order crimp contacts separately



Insert	Designation	Order No.
Male	HE-016-MC	122 016 010 0001
	HE-016-MC(17-32) <sup>1)</sup>	122 016 010 0002
Female	HE-016-FC	122 016 020 0001
	HE-016-FC(17-32) <sup>1)</sup>	122 016 020 0002

<sup>1)</sup>can match PCB adapter,see page 14-04-14-05.

Spring terminal, See P00-14 for the structural characteristics of spring.



Insert	Designation	Order No.
Male	HE-016-MS	122 016 012 0001
	HE-016-MS(17-32)	122 016 012 0002
Female	HE-016-FS	122 016 022 0001
	HE-016-FS(17-32)	122 016 022 0002
Male	HE-016-MS B	122 016 012 0101
	HE-016-MS B(17-32)	122 016 012 0102
Female	HE-016-FS B	122 016 022 0101
	HE-016-FS B(17-32)	122 016 022 0102
Double spring connection(Two terminal per contact) Only suitable for high structure shells		
Male	HE-016-MSS	122 016 012 0201
	HE-016-MSS(17-32)	122 016 012 0202
Female	HE-016-FSS	122 016 022 0201
	HE-016-FSS(17-32)	122 016 022 0202

1) Distance for contact max. 21 mm

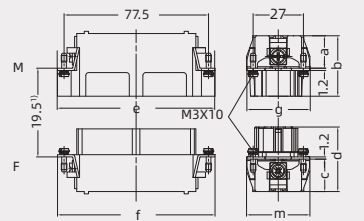

M/F	a	b	e	g	c	d	f	m
MC/FC	18	33.5	84.5	34	18	35	84.5	34
MS/FS	18	33.7	84.5	34	18.2	35.5	84.5	34
MSS/FSS	34.3	49	84.5	34	32.2	49	84.5	34
MS B / FS B	19.6	34.7	84.3	34	18.6	36	84.5	34

Contact arrangement view from termination side

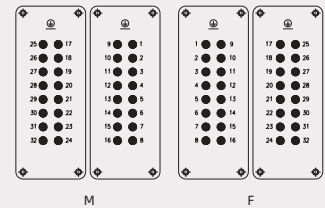

Panel cut out for inserts for use without hoods/housings

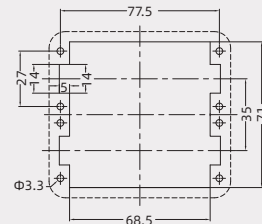

Crimp contacts

Crimp contacts 16A

Contact resistance ≤ 1mΩ  
silver plated



Male	Order No.	Female	Order No.
CESM-0.37	101 019 110 0301	CESF-0.37	101 019 120 0301
CESM-0.50	101 019 110 0401	CESF-0.50	101 019 120 0401
CESM-0.75	101 019 110 0601	CESF-0.75	101 019 120 0601
CESM-1.0	101 019 110 0801	CESF-1.0	101 019 120 0801
CESM-1.5	101 019 110 0901	CESF-1.5	101 019 120 0901
CESM-2.5	101 019 110 1001	CESF-2.5	101 019 120 1001
CESM-3.0	101 019 110 1101	CESF-3.0	101 019 120 1101
CESM-4.0	101 019 110 1201	CESF-4.0	101 019 120 1201

gold plated



CEGM-0.37	101 019 210 0301	CEGF-0.37	101 019 220 0301
CEGM-0.50	101 019 210 0401	CEGF-0.50	101 019 220 0401
CEGM-0.75	101 019 210 0601	CEGF-0.75	101 019 220 0601
CEGM-1.0	101 019 210 0801	CEGF-1.0	101 019 220 0801
CEGM-1.5	101 019 210 0901	CEGF-1.5	101 019 220 0901
CEGM-2.5	101 019 210 1001	CEGF-2.5	101 019 220 1001
CEGM-3.0	101 019 210 1101	CEGF-3.0	101 019 220 1101
CEGM-4.0	101 019 210 1201	CEGF-4.0	101 019 220 1201

More crimp contacts 16A see P13-04.

Tools

Crimping tool



Contact removal tool



Wire gauge	Designation	Order No.
0.14-4mm <sup>2</sup>	TL02G	198 001 001 0011

Wire gauge: 0.14-0.37mm<sup>2</sup> please select TL02 Crimping tool.

Application	Designation	Order No.
for crimp contacts 16A	TL01	198 001 000 0002

More tools detail please find the page 32-03-32-06.

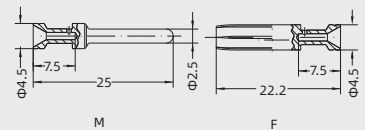

Identification	Wire gauge	Stripping length
no groove	0.14-0.37 mm <sup>2</sup>   AWG 26-22	7.5mm
no groove	0.5 mm <sup>2</sup>   AWG 20	7.5mm
1 groove	0.75 mm <sup>2</sup>   AWG 18	7.5mm
1 groove	1 mm <sup>2</sup>   AWG 18	7.5mm
2 grooves	1.5 mm <sup>2</sup>   AWG 16	7.5mm
3 grooves	2.5 mm <sup>2</sup>   AWG 14	7.5mm
wide groove	3 mm <sup>2</sup>   AWG 12	7.5mm
no groove	4 mm <sup>2</sup>   AWG 12	7.5mm

When the wire gauge is less than 0.75mm<sup>2</sup>, it's better to use the auxiliary pin assembly tool TL15.

Notes: The tools for crimp terminal may influence the product quality and stability. Please select the tools recognized by our company.

HE-048 Standard inserts

500V 16A 48+



Inserts

Hoods/Housings: size 48B, please find the details on page 15-160~15-162.

Screw terminal



Insert	Designation	Order No.
Male	HE-024-M	122 024 011 0001
	HE-024-M(25-48) <sup>1)</sup>	122 024 011 0002
Female	HE-024-F	122 024 021 0001
	HE-024-F(25-48)	122 024 021 0002

Crimp terminal

Order crimp contacts separately



Insert	Designation	Order No.
Male	HE-024-MC	122 024 010 0001
	HE-024-MC(25-48) <sup>1)</sup>	122 024 010 0002
Female	HE-024-FC	122 024 020 0001
	HE-024-FC(25-48) <sup>1)</sup>	122 024 020 0002

<sup>1)</sup>can match PCB adapter,see page 14-04-14-05.

Spring terminal, See P00-14 for the structural characteristics of spring.



Insert	Designation	Order No.
Male	HE-024-MS	122 024 012 0001
	HE-024-MS(25-48)	122 024 012 0002
Female	HE-024-FS	122 024 022 0001
	HE-024-FS(25-48)	122 024 022 0002
Male	HE-024-MS B	122 024 012 0101
	HE-024-MS B(25-48)	122 024 012 0102
Female	HE-024-FS B	122 024 022 0101
	HE-024-FS B(25-48)	122 024 022 0102
Double spring connection(Two terminal per contact) Only suitable for high structure shells		
Male	HE-024-MSS	122 024 012 0201
	HE-024-MSS(25-48)	122 024 012 0202
Female	HE-024-FSS	122 024 022 0201
	HE-024-FSS(25-48)	122 024 022 0202

1) Distance for contact max. 21 mm

M/F	a	b	e	g	c	d	f	m
M/F	17	32.5	111	33.5	17	34.5	111	33.5
MC/FC	18.3	33.5	111	34	18.3	35.5	111	34
MS/FS	18.5	33.6	111	34	18.5	35.6	111	34
MSS/FSS	34	49	110	34	32	49	110	34
MS B / FS B	19.6	34.7	111	34	19	36.2	111	34

Contact arrangement view from termination side

HE

Crimp contacts

Crimp contacts 16A

Contact resistance ≤ 1mΩ  
silver plated



Male	Order No.	Female	Order No.
CESM-0.37	101 019 110 0301	CESF-0.37	101 019 120 0301
CESM-0.50	101 019 110 0401	CESF-0.50	101 019 120 0401
CESM-0.75	101 019 110 0601	CESF-0.75	101 019 120 0601
CESM-1.0	101 019 110 0801	CESF-1.0	101 019 120 0801
CESM-1.5	101 019 110 0901	CESF-1.5	101 019 120 0901
CESM-2.5	101 019 110 1001	CESF-2.5	101 019 120 1001
CESM-3.0	101 019 110 1101	CESF-3.0	101 019 120 1101
CESM-4.0	101 019 110 1201	CESF-4.0	101 019 120 1201

gold plated



Male	Order No.	Female	Order No.
CEGM-0.37	101 019 210 0301	CEGF-0.37	101 019 220 0301
CEGM-0.50	101 019 210 0401	CEGF-0.50	101 019 220 0401
CEGM-0.75	101 019 210 0601	CEGF-0.75	101 019 220 0601
CEGM-1.0	101 019 210 0801	CEGF-1.0	101 019 220 0801
CEGM-1.5	101 019 210 0901	CEGF-1.5	101 019 220 0901
CEGM-2.5	101 019 210 1001	CEGF-2.5	101 019 220 1001
CEGM-3.0	101 019 210 1101	CEGF-3.0	101 019 220 1101
CEGM-4.0	101 019 210 1201	CEGF-4.0	101 019 220 1201

More crimp contacts 16A see P13-04.

Tools

Crimping tool



Wire gauge	Designation	Order No.
0.14-4mm <sup>2</sup>	TL02G	198 001 001 0011

Wire gauge: 0.14-0.37mm<sup>2</sup> please select TL02 Crimping tool.

Contact removal tool



Application	Designation	Order No.
for crimp contacts 16A	TL01	198 001 000 0002

More tools detail please find the page 32-03-32-06.

Identification	Wire gauge	Stripping length
no groove	0.14-0.37 mm <sup>2</sup>	AWG 26-22
no groove	0.5 mm <sup>2</sup>	AWG 20
1 groove	0.75 mm <sup>2</sup>	AWG 18
1 groove	1 mm <sup>2</sup>	AWG 18
2 grooves	1.5 mm <sup>2</sup>	AWG 16
3 grooves	2.5 mm <sup>2</sup>	AWG 14
wide groove	3 mm <sup>2</sup>	AWG 12
no groove	4 mm <sup>2</sup>	AWG 12

When the wire gauge is less than 0.75mm<sup>2</sup>, it's better to use the auxiliary pin assembly tool TL15.

Notes: The tools for crimp terminal may influence the product quality and stability. Please select the tools recognized by our company.



## HE Shrapnel push tool

## Tools

HE B Spring open machine<sup>1)</sup>

Description	Designation	Order NO.
for all HE B spring inserts	SOM01	198 001 003 0008

1) It can open all the shrapnel windows of insert at one time; suitable for using in mass assembly, greatly improving the efficiency of the connection.





## HVE SERIES

High voltage connector

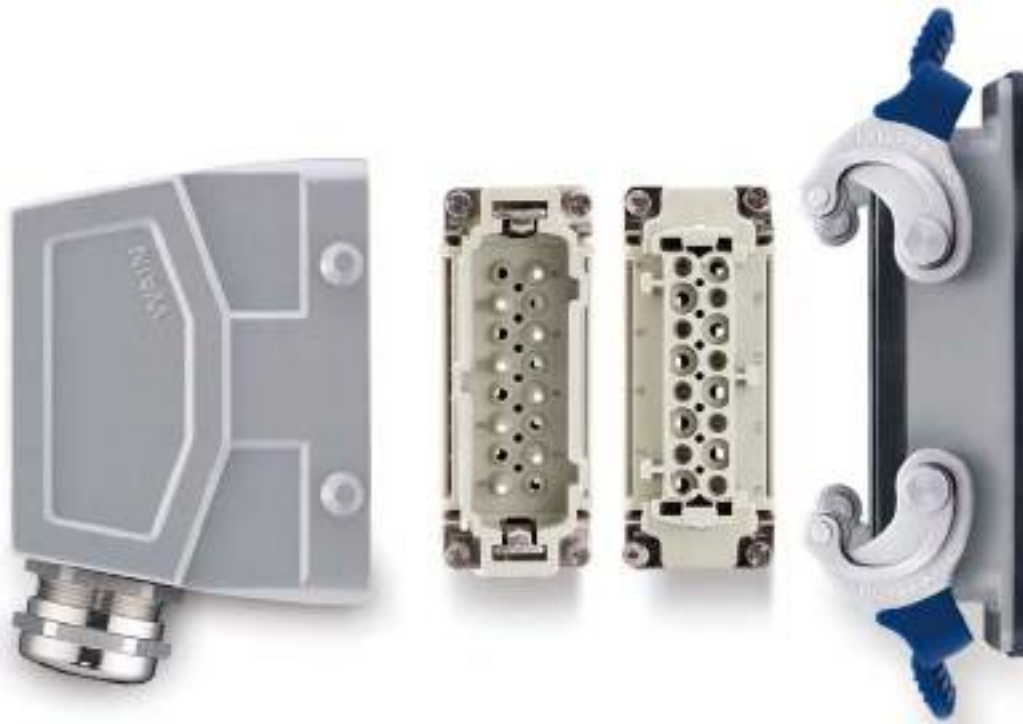

## HVE SERIES High voltage inserts

### Technical characteristics

Specifications	DIN EN 60 664 DIN EN 61 984
Approvals	
Inserts	
Number of contacts	3,6,10,12,20+PE
Electrical data acc. to DIN EN 61 984	
-Rated current	16A
-Rated voltage	830V
-Rated impulse voltage	8kV
-Pollution degree	3
-Pollution degree 2 also	16A 1000V 8kV 2
-or	16A 720/1250V 8kV 2
-Relay contacts	16A 500V 6kV 3
Rated voltage acc. to UL	600V
Relay contacts	250V
Insulation resistance	$\geq 10^{10}\Omega$
Material	polycarbonate
Limiting temperatures	-40°C ...+125°C
Flammability acc. to UL 94	V0
Mechanical working life(mating cycles)	$\geq 500$
Contacts	
Material	copper alloy
Surface	hard-silver plated
Contact resistance	$\leq 1m\Omega$
Screw terminal	
-Wire gauge	1.0-2.5mm <sup>2</sup>
-AWG	18-14
-Tightening/test torque	0.5Nm
-Stripping length	7.0mm
Crimp terminal	
-Wire gauge	0.14-4.0mm <sup>2</sup>
-AWG	26-12
-Stripping length	7.5mm

For a fully equipped crimp connector the following contacts are required:

Type	Contacts total	Operating contacts	Relay contacts
HVE-003	5	3	2
HVE-006	8	6	2
HVE-010	12	10	2
HVE-012	16	12	4
HVE-020	24	20	4

### Current carrying capacity

The current carrying is limited by maximum temperature of materials for inserts and contacts including terminals

Control and test procedures according to DIN EN 60512-5

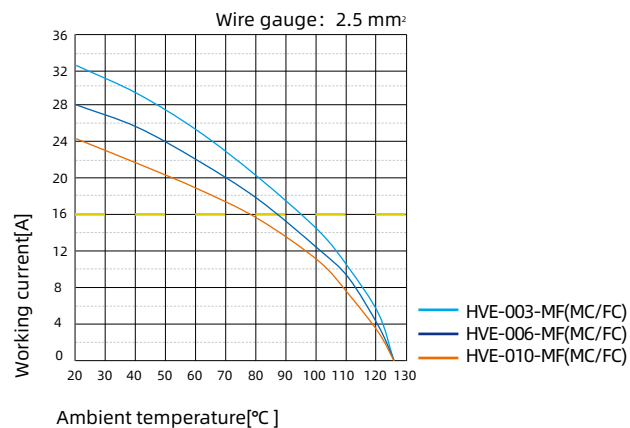
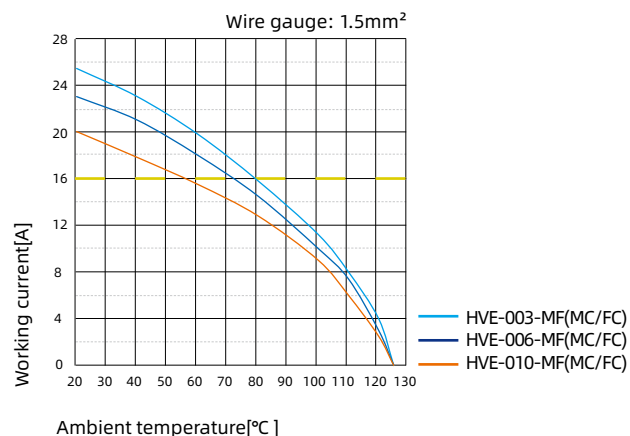

## HVE-003 High voltage inserts

830V 16A 3+2+ ⊕



### Inserts

Hoods/Housings: Screw terminal size **10B Plastic** or **WV10B/HV10B**, please find the details on page 15-39, 15-60~15-69.

Crimp terminal size **10B**, please find the details on page 15-39~15-69.

#### Screw terminal



Insert	Designation	Order No.
Male	HVE-003-M	124 003 011 0001
Female	HVE-003-F	124 003 021 0001

#### Crimp terminal

Order crimp contacts separately



Insert	Designation	Order No.
Male	HVE-003-MC	124 003 010 0001
Female	HVE-003-FC	124 003 020 0001

1) Distance for contact max. 21 mm

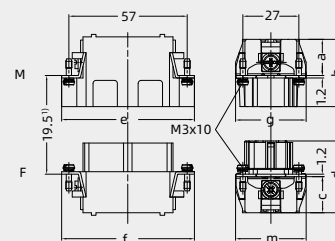

	a	b	e	g	c	d	f	m
M/F	16.5	32	64.5	34	16.8	34.2	64	34
MC/FC	18	33	64	34	17.5	35.2	64	34

Contact arrangement view from termination side

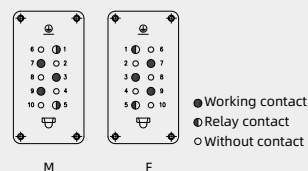

Panel cut out for inserts for use without hoods/housings

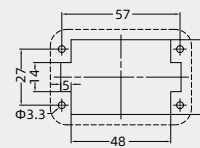

## Crimp contacts

### Crimp contacts 16A

16A Operating contacts  
Contact resistance ≤ 1mΩ  
silver plated



Relay contacts<sup>2)</sup>  
silver plated



Male	Order No.	Female	Order No.
CESM-0.37	101 019 110 0301	CESF-0.37	101 019 120 0301
CESM-0.50	101 019 110 0401	CESF-0.50	101 019 120 0401
CESM-0.75	101 019 110 0601	CESF-0.75	101 019 120 0601
CESM-1.0	101 019 110 0801	CESF-1.0	101 019 120 0801
CESM-1.5	101 019 110 0901	CESF-1.5	101 019 120 0901
CESM-2.5	101 019 110 1001	CESF-2.5	101 019 120 1001
CESM-3.0	101 019 110 1101	CESF-3.0	101 019 120 1101
CESM-4.0	101 019 110 1201	CESF-4.0	101 019 120 1201

Wire gauge	Designation	Order No.
1	CESM-1.0R	101 019 110 0808
1.5	CESM-1.5R	101 019 110 0908
2.5	CESM-2.5R	101 019 110 1008

More crimp contacts 16A see P13-04.

#### Tools

Crimping tool



Contact removal tool



Wire gauge	Designation	Order No.
0.14-4mm <sup>2</sup>	TL02G	198 001 001 0011

Wire gauge: 0.14-0.37mm<sup>2</sup> please select TL02 Crimping tool.

Application	Designation	Order No.
for crimp contacts 16A	TL01	198 001 000 0002

More tools detail please find the page 32-03~32-06.

Notes: The tools for crimp terminal may influence the product quality and stability. Please select the tools recognized by our company.

2) Delay pin is relatively short, delay contact, protect circuit to avoid electric arc.

HVE-006 Standard inserts

830V 16A 6+2+⊕



Hoods/Housings: Screw terminal size 16B Plastic or WV16B/HV16B, please find the details on page 15-70, 15-68~96-107.1  
Crimp terminal size 16B, please find the details on page 15-70~15-107.

Inserts

Screw terminal



Insert	Designation	Order No.
Male	HVE-006-M	124 006 011 0001
Female	HVE-006-F	124 006 021 0001

Crimp terminal

Order crimp contacts separately



Insert	Designation	Order No.
Male	HVE-006-MC	124 006 010 0001
Female	HVE-006-FC	124 006 020 0001

1) Distance for contact max. 21 mm

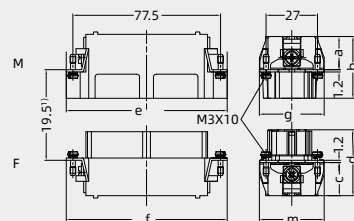

	a	b	e	g	c	d	f	m
M/F	18	32.5	84.5	34	18	34.5	84.5	34
MC/FC	18	33.5	84.5	34	18	35	84.5	34

Contact arrangement view from termination side

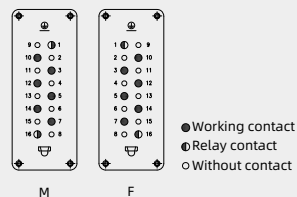

Panel cut out for inserts for use without hoods/housings

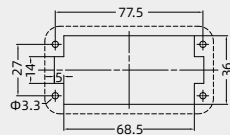

Crimp contacts

Crimp contacts 16A

16A Operating contacts  
Contact resistance ≤ 1mΩ  
silver plated



Relay contacts<sup>2)</sup>  
silver plated



More crimp contacts 16A see P13-04.

Tools

Crimping tool



Contact removal tool



Male	Order No.	Female	Order No.
CESM-0.37	101 019 110 0301	CESF-0.37	101 019 120 0301
CESM-0.50	101 019 110 0401	CESF-0.50	101 019 120 0401
CESM-0.75	101 019 110 0601	CESF-0.75	101 019 120 0601
CESM-1.0	101 019 110 0801	CESF-1.0	101 019 120 0801
CESM-1.5	101 019 110 0901	CESF-1.5	101 019 120 0901
CESM-2.5	101 019 110 1001	CESF-2.5	101 019 120 1001
CESM-3.0	101 019 110 1101	CESF-3.0	101 019 120 1101
CESM-4.0	101 019 110 1201	CESF-4.0	101 019 120 1201

Wire gauge	Designation	Order No.
1	CESM-1.0R	101 019 110 0808
1.5	CESM-1.5R	101 019 110 0908
2.5	CESM-2.5R	101 019 110 1008

Wire gauge	Designation	Order No.
0.14-4mm <sup>2</sup>	TL02G	198 001 001 0011

Application	Designation	Order No.
Wire gauge: 0.14-0.37mm <sup>2</sup> please select TL02 Crimping tool.		
for crimp contacts 16A	TL01	198 001 000 0002

More tools detail please find the page 32-03~32-06.

Notes: The tools for crimp terminal may influence the product quality and stability. Please select the tools recognized by our company.  
2) Delay pin is relatively short, delay contact, protect circuit to avoid electric arc.

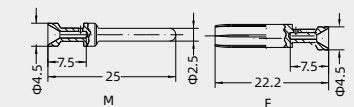

Identification	Wire gauge	Stripping length
no groove	0.14-0.37 mm <sup>2</sup> AWG 26-22	7.5mm
no groove	0.5 mm <sup>2</sup> AWG 20	7.5mm
1 groove	0.75 mm <sup>2</sup> AWG 18	7.5mm
1 groove	1 mm <sup>2</sup> AWG 18	7.5mm
2 grooves	1.5 mm <sup>2</sup> AWG 16	7.5mm
3 grooves	2.5 mm <sup>2</sup> AWG 14	7.5mm
wide groove	3 mm <sup>2</sup> AWG 12	7.5mm
no groove	4 mm <sup>2</sup> AWG 12	7.5mm

When the wire gauge is less than 0.75mm<sup>2</sup>, it's better to use the auxiliary pin assembly tool TL15.

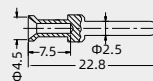

## HVE-010 High voltage inserts

830V 16A 10+2+



Hoods/Housings: Screw terminal size **24B Plastic** or **WV24B/HV24B**, please find the details on page 15-108, 15-136~15-150.  
Crimp terminal size **24B**, please find the details on page 15-108~15-150.

### Inserts

#### Screw terminal



Insert	Designation	Order No.
Male	HVE-010-M	124 010 011 0001
Female	HVE-010-F	124 010 021 0001

#### Crimp terminal

Order crimp contacts separately



Insert	Designation	Order No.
Male	HVE-010-MC	124 010 010 0001
Female	HVE-010-FC	124 010 020 0001

1) Distance for contact max. 21 mm

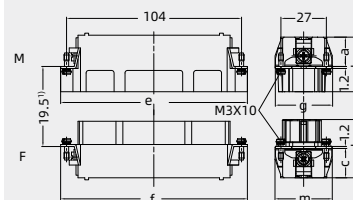

	a	b	e	g	c	d	f	m
M/F	17	32.5	111	33.5	17	34.5	111	33.5
MC/FC	18.3	33.5	111	34	18.3	35.5	111	34

Contact arrangement view from termination side

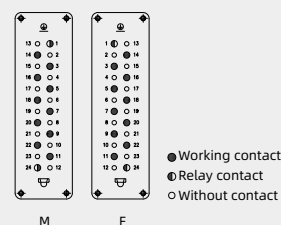

Panel cut out for inserts for use without hoods/housings

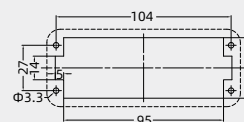

### Crimp contacts

#### Crimp contacts 16A

16A Operating contacts  
Contact resistance ≤ 1mΩ  
silver plated



Relay contacts<sup>2)</sup>  
silver plated



More crimp contacts 16A see P13-04.

#### Tools

Crimping tool



Contact removal tool



Male	Order No.	Female	Order No.
CESM-0.37	101 019 110 0301	CESF-0.37	101 019 120 0301
CESM-0.50	101 019 110 0401	CESF-0.50	101 019 120 0401
CESM-0.75	101 019 110 0601	CESF-0.75	101 019 120 0601
CESM-1.0	101 019 110 0801	CESF-1.0	101 019 120 0801
CESM-1.5	101 019 110 0901	CESF-1.5	101 019 120 0901
CESM-2.5	101 019 110 1001	CESF-2.5	101 019 120 1001
CESM-3.0	101 019 110 1101	CESF-3.0	101 019 120 1101
CESM-4.0	101 019 110 1201	CESF-4.0	101 019 120 1201

Wire gauge	Designation	Order No.
1	CESM-1.0R	101 019 110 0808
1.5	CESM-1.5R	101 019 110 0908
2.5	CESM-2.5R	101 019 110 1008

Wire gauge	Designation	Order No.
0.14-4mm <sup>2</sup>	TL02G	198 001 001 0011

Wire gauge: 0.14-0.37mm<sup>2</sup> please select TL02 Crimping tool.

Application	Designation	Order No.
for crimp contacts 16A	TL01	198 001 000 0002

More tools detail please find the page 32-03~32-06.

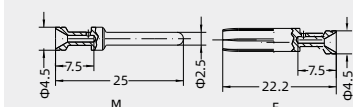

Identification	Wire gauge	Stripping length
no groove	0.14-0.37 mm <sup>2</sup> AWG 26-22	7.5mm
no groove	0.5 mm <sup>2</sup> AWG 20	7.5mm
1 groove	0.75 mm <sup>2</sup> AWG 18	7.5mm
1 groove	1 mm <sup>2</sup> AWG 18	7.5mm
2 grooves	1.5 mm <sup>2</sup> AWG 16	7.5mm
3 grooves	2.5 mm <sup>2</sup> AWG 14	7.5mm
wide groove	3 mm <sup>2</sup> AWG 12	7.5mm
no groove	4 mm <sup>2</sup> AWG 12	7.5mm

When the wire gauge is less than 0.75mm<sup>2</sup>, it's better to use the auxiliary pin assembly tool TL15.

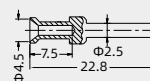

Notes: The tools for crimp terminal may influence the product quality and stability. Please select the tools recognized by our company.

2) Delay pin is relatively short, delay contact, protect circuit to avoid electric arc.



# HVE-012 High voltage inserts

830V 16A 12+4+ ⚡



Hoods/Housings: Screw terminal size **WV32B/HV32B**, please find the details on page 15-156~15-159.  
Crimp terminal size **32B**, please find the details on page 15-151~15-159.

## Inserts

### Screw terminal



Insert	Designation	Order No.
Male	HVE-006-M	124 006 011 0001
	HVE-006-M(7-12)	124 006 011 0002
Female	HVE-006-F	124 006 021 0001
	HVE-006-F(7-12)	124 006 021 0002

### Crimp terminal

Order crimp contacts separately



Insert	Designation	Order No.
Male	HVE-006-MC	124 006 010 0001
	HVE-006-MC(7-12)	124 006 010 0002
Female	HVE-006-FC	124 006 020 0001
	HVE-006-FC(7-12)	124 006 020 0002

1) Distance for contact max. 21 mm

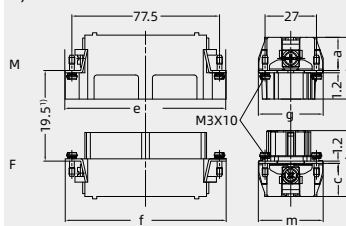

	a	b	e	g	c	d	f	m
M/F	18	32.5	84.5	34	18	34.5	84.5	34
MC/FC	18	33.5	84.5	34	18	35	84.5	34

Contact arrangement view from termination side

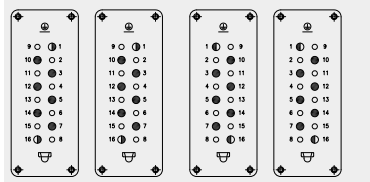

Panel cut out for inserts for use without hoods/housings

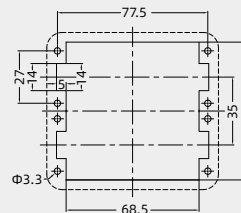

## Crimp contacts

### Crimp contacts 16A

16A Operating contacts  
Contact resistance ≤ 1mΩ  
silver plated



Relay contacts<sup>2)</sup>  
silver plated



Male	Order No.	Female	Order No.
CESM-0.37	101 019 110 0301	CESF-0.37	101 019 120 0301
CESM-0.50	101 019 110 0401	CESF-0.50	101 019 120 0401
CESM-0.75	101 019 110 0601	CESF-0.75	101 019 120 0601
CESM-1.0	101 019 110 0801	CESF-1.0	101 019 120 0801
CESM-1.5	101 019 110 0901	CESF-1.5	101 019 120 0901
CESM-2.5	101 019 110 1001	CESF-2.5	101 019 120 1001
CESM-3.0	101 019 110 1101	CESF-3.0	101 019 120 1101
CESM-4.0	101 019 110 1201	CESF-4.0	101 019 120 1201

Wire gauge	Designation	Order No.
1	CESM-1.0R	101 019 110 0808
1.5	CESM-1.5R	101 019 110 0908
2.5	CESM-2.5R	101 019 110 1008

More crimp contacts 16A see P13-04.

### Tools

Crimping tool



Contact removal tool



Wire gauge	Designation	Order No.
0.14-4mm <sup>2</sup>	TL02G	198 001 001 0011

Wire gauge: 0.14-0.37mm<sup>2</sup> please select TL02 Crimping tool.

Application	Designation	Order No.
for crimp contacts 16A	TL01	198 001 000 0002

More tools detail please find the page 32-03~32-06.

Notes: The tools for crimp terminal may influence the product quality and stability. Please select the tools recognized by our company.  
2) Delay pin is relatively short, delay contact, protect circuit to avoid electric arc.

Identification	Wire gauge	Stripping length	
no groove	0.14-0.37 mm <sup>2</sup>	AWG 26-22	7.5mm
no groove	0.5 mm <sup>2</sup>	AWG 20	7.5mm
1 groove	0.75 mm <sup>2</sup>	AWG 18	7.5mm
1 groove	1 mm <sup>2</sup>	AWG 18	7.5mm
2 grooves	1.5 mm <sup>2</sup>	AWG 16	7.5mm
3 grooves	2.5 mm <sup>2</sup>	AWG 14	7.5mm
wide groove	3 mm <sup>2</sup>	AWG 12	7.5mm
no groove	4 mm <sup>2</sup>	AWG 12	7.5mm

When the wire gauge is less than 0.75mm<sup>2</sup>, it's better to use the auxiliary pin assembly tool TL15.

## HVE-020 High voltage inserts

830V 16A 20+4+ 



### Inserts

Hoods/Housings: Screw terminal size WV48B/HV48B, please find the details on page 15-162.  
Crimp terminal size 48B, please find the details on page 15-160~15-162.

#### Screw terminal



Insert	Designation	Order No.
Male	HVE-010-M	124 010 011 0001
	HVE-010-M(11-20)	124 010 011 0002
Female	HVE-010-F	124 010 021 0001
	HVE-010-F(11-20)	124 010 021 0002

#### Crimp terminal

Order crimp contacts separately



Insert	Designation	Order No.
Male	HVE-010-MC	124 010 010 0001
	HVE-010-MC(11-20)	124 010 010 0002
Female	HVE-010-FC	124 010 020 0001
	HVE-010-FC(11-20)	124 010 020 0002

1) Distance for contact max. 21 mm

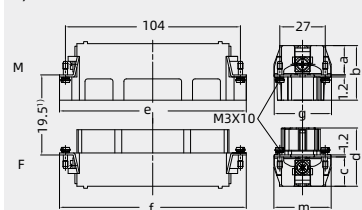

	a	b	e	g	c	d	f	m
M/F	17	32.5	111	33.5	17	34.5	111	33.5
MC/FC	18.3	33.5	111	34	18.3	35.5	111	34

Contact arrangement view from termination side

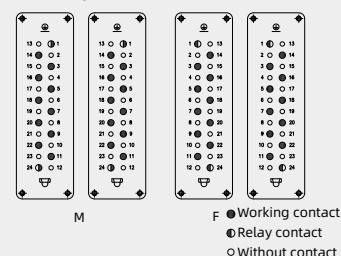

Panel cut out for inserts for use without hoods/housings

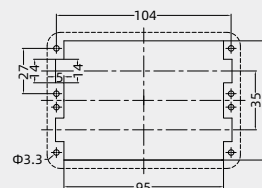

### Crimp contacts

#### Crimp contacts 16A

16A Operating contacts  
Contact resistance ≤ 1mΩ  
silver plated



Relay contacts<sup>2)</sup>  
silver plated



More crimp contacts 16A see P13-04.

#### Tools

##### Crimping tool



##### Contact removal tool



Male	Order No.	Female	Order No.
CESM-0.37	101 019 110 0301	CESF-0.37	101 019 120 0301
CESM-0.50	101 019 110 0401	CESF-0.50	101 019 120 0401
CESM-0.75	101 019 110 0601	CESF-0.75	101 019 120 0601
CESM-1.0	101 019 110 0801	CESF-1.0	101 019 120 0801
CESM-1.5	101 019 110 0901	CESF-1.5	101 019 120 0901
CESM-2.5	101 019 110 1001	CESF-2.5	101 019 120 1001
CESM-3.0	101 019 110 1101	CESF-3.0	101 019 120 1101
CESM-4.0	101 019 110 1201	CESF-4.0	101 019 120 1201

Wire gauge	Designation	Order No.
1	CESM-1.0R	101 019 110 0808
1.5	CESM-1.5R	101 019 110 0908
2.5	CESM-2.5R	101 019 110 1008

Wire gauge	Designation	Order No.
0.14-4mm <sup>2</sup>	TL02G	198 001 001 0011

Application	Designation	Order No.
Wire gauge: 0.14-0.37mm <sup>2</sup> please select TL02 Crimping tool.		
for crimp contacts 16A	TL01	198 001 000 0002

More tools detail please find the page 32-03~32-06.

Notes: The tools for crimp terminal may influence the product quality and stability. Please select the tools recognized by our company.  
2) Delay pin is relatively short, delay contact, protect circuit to avoid electric arc.

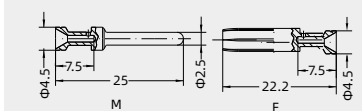

Identification	Wire gauge	Stripping length
no groove	0.14-0.37 mm <sup>2</sup> AWG 26-22	7.5mm
no groove	0.5 mm <sup>2</sup> AWG 20	7.5mm
1 groove	0.75 mm <sup>2</sup> AWG 18	7.5mm
1 groove	1 mm <sup>2</sup> AWG 18	7.5mm
2 grooves	1.5 mm <sup>2</sup> AWG 16	7.5mm
3 grooves	2.5 mm <sup>2</sup> AWG 14	7.5mm
wide groove	3 mm <sup>2</sup> AWG 12	7.5mm
no groove	4 mm <sup>2</sup> AWG 12	7.5mm

When the wire gauge is less than 0.75mm<sup>2</sup>, it's better to use the auxiliary pin assembly tool TL15.

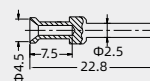

## HVE-016 High voltage inserts

### Technical characteristics

Specifications	DIN EN 60 664 DIN EN 61 984
Approvals	
Inserts	
Number of contacts	16,32+PE + 2 additional contacts for safe high voltage connections
Electrical data acc. to DIN EN 61 984	
-Rated current	16A
-Rated voltage conductor - ground	400V
-Rated voltage conductor - conductor	690V
-Rated impulse voltage	6kV
-Pollution degree	3
-or	16A 500V 6kV 3
Rated voltage acc. to UL	600V
Relay contacts	250V
Insulation resistance	$\geq 10^{10}\Omega$
Material	polycarbonate
Limiting temperatures	-40°C ...+125°C
Flammability acc. to UL 94	V0
Mechanical working life(mating cycles)	$\geq 500$
Contacts	
Material	copper alloy
Surface	hard-silver plated
Contact resistance	$\leq 1m\Omega$
Screw terminal	
-Wire gauge	2.5mm <sup>2</sup>
-AWG	14
-Tightening/test torque	0.5Nm

### Current carrying capacity

The current carrying is limited by maximum temperature of materials for inserts and contacts including terminals  
Control and test procedures according to DIN EN 60512-5

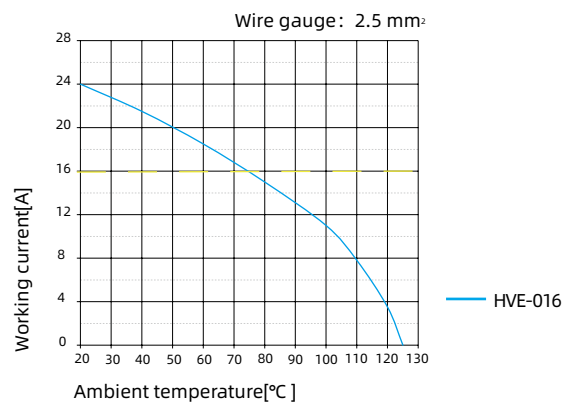
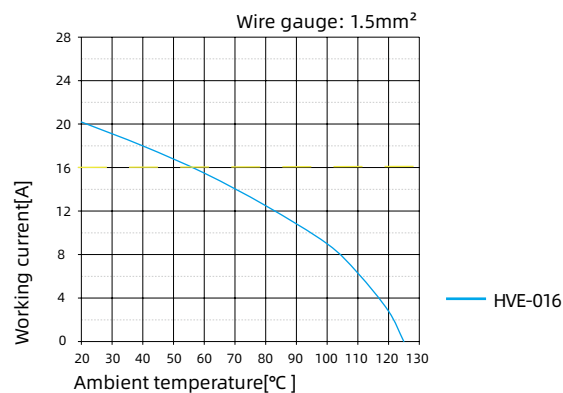

# HVE-016 High voltage inserts

400V/690V 16A 16+2+ 



## Inserts

Hoods/Housings: size **24B Plastic** or **WV24B/HV24B**, please find the details on page 15-108, 15-136~15-150.

Screw terminal



Insert	Designation	Order No.
Male	HVE-016-M	124 016 011 0001
Female	HVE-016-F	124 016 021 0001

1) Distance for contact max. 21 mm

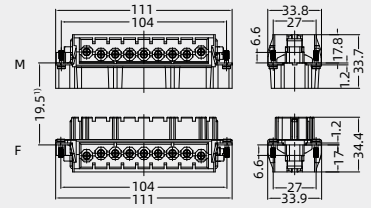

Contact arrangement view from termination side

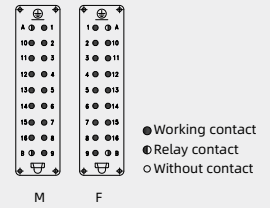

Panel cut out for inserts for use without hoods/housings

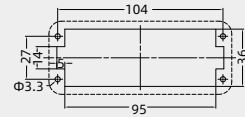

# HVE-032 High voltage inserts

400V/690V 16A 32+4+ 



## Inserts

Hoods/Housings: size **WV48B/HV48B**, please find the details on page 15-162.

### Screw terminal



Insert	Designation	Order No.
Male	HVE-016-M	124 006 011 0001
	HVE-016-M(17-32)	124 016 011 0002
Female	HVE-016-F	124 006 021 0001
	HVE-016-F(17-32)	124 016 021 0002

1) Distance for contact max. 21 mm

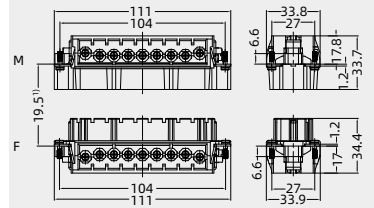

Contact arrangement view from termination side

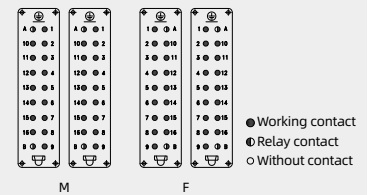

Panel cut out for inserts for use without hoods/housings

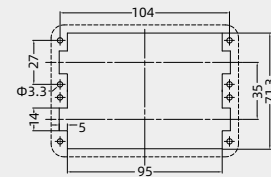

## Difference between applicable housing and standard housing of HVE series

### B standard Hoods/Housings

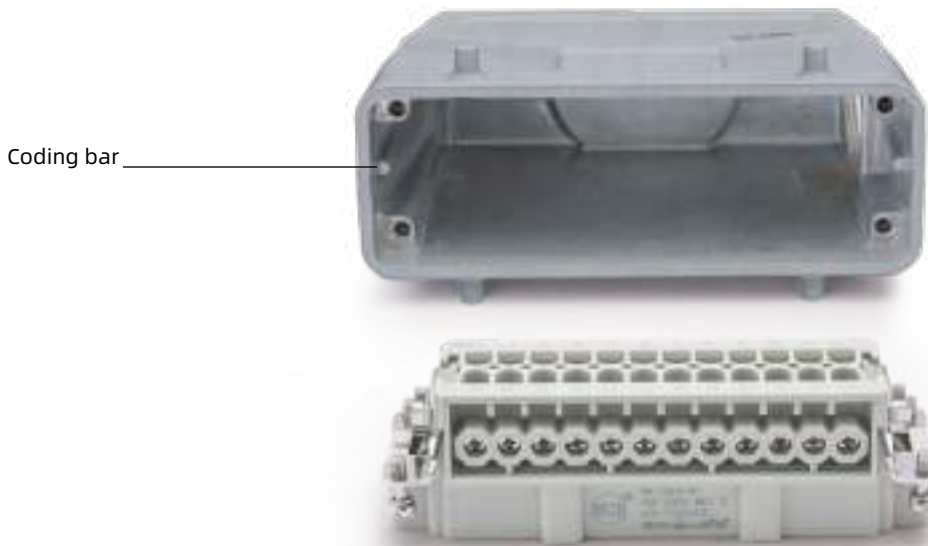

### Special HVE Hoods/Housings

For HVE screw inserts, the screw inserts may be used together the corresponding HVE Hoods/Housings only.





# HVES SERIES

High voltage connector(spring piece connector)





# HVES SERIES High voltage inserts

## Technical characteristics

Specifications	DIN EN 60 664 DIN EN 61 984
Approvals	 ENEC
Inserts	
Number of contacts	3,6,10,12,20+PE
	+ 2 additional contacts for safe high voltage connections
<b>Electrical data acc. to DIN EN 61 984</b>	
-Rated current	16A
-Rated voltage	830V
-Rated impulse voltage	8kV
-Pollution degree	3
-Pollution degree 2 also	16A 1000V 8kV 2
-or	16A 720/1250V 8kV 2
-Relay contacts	16A 500V 6kV 3
Rated voltage acc. to UL	600V
Relay contacts	250V
Insulation resistance	$\geq 10^{10}\Omega$
Material	polycarbonate
Limiting temperatures	-40°C ...+125°C
Flammability acc. to UL 94	V0
Mechanical working life(mating cycles)	$\geq 500$
<b>Contacts</b>	
Material	copper alloy
Surface	hard-silver plated
Contact resistance	$\leq 3m\Omega$
<b>Spring terminal</b>	
-wire gauge	0.14-2.5mm <sup>2</sup>
-AWG	26-14
-Stripping length	7-9mm

## Current carrying capacity

The current carrying is limited by maximum temperature of materials for inserts and contacts including terminals

Control and test procedures according to DIN EN 60512-5

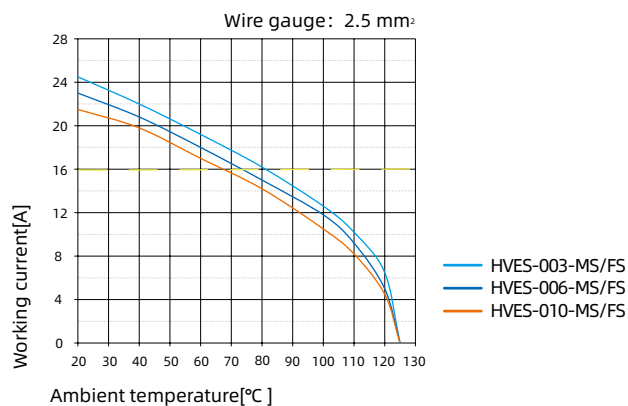
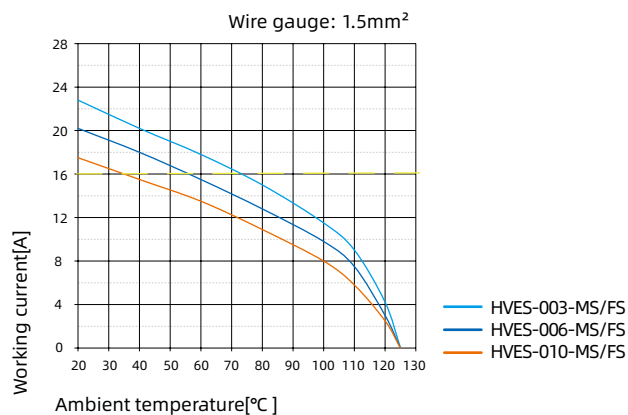

# HVE-003 High voltage inserts

830V 16A 3+2+ 



## Inserts

Hoods/Housings: size 10B, please find the details on page 15-39~15-69.

Spring terminal, See P00-14 for the structural characteristics of spring.



Insert	Designation	Order No.
Male	HVE-003-MS	124 003 012 0001
Female	HVE-003-FS	124 003 022 0001

1) Distance for contact max. 21 mm

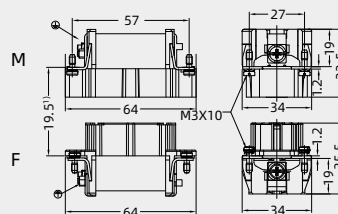

Contact arrangement view from termination side

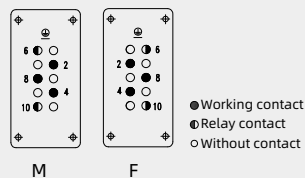

Panel cut out for inserts for use without hoods/housings

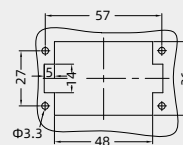

# HVE-006 High voltage inserts

830V 16A 6+2+ 



## Inserts

Hoods/Housings: size 16B, please find the details on page 15-70~15-1071.

Spring terminal, See P00-14 for the structural characteristics of spring.



Insert	Designation	Order No.
Male	HVE-006-MS	124 006 012 0001
Female	HVE-006-FS	124 006 022 0001

1) Distance for contact max. 21 mm

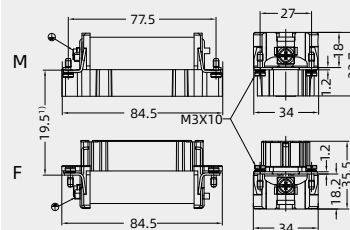

Contact arrangement view from termination side

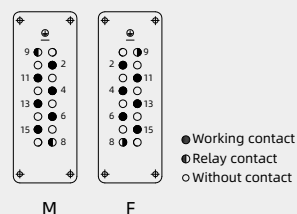

Panel cut out for inserts for use without hoods/housings

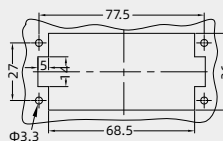



# HVE-012 High voltage inserts

830V 16A 12+4+ 

EH

## Inserts

Hoods/Housings: size 32B, please find the details on page 15-151~15-159.

Spring terminal, See P00-14 for the structural characteristics of spring.



Insert	Designation	Order No.
Male	HVE-006-MS	124 006 012 0001
	HVE-006-MS(7-12)	124 006 012 0002
Female	HVE-006-FS	124 006 022 0001
	HVE-006-FS(7-12)	124 006 022 0002

1) Distance for contact max. 21 mm

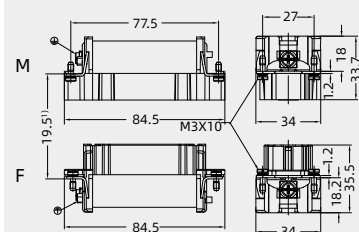

Contact arrangement view from termination side

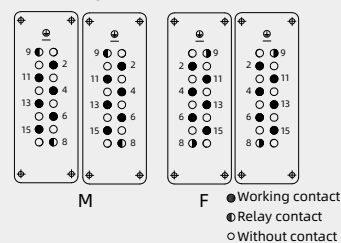

Panel cut out for use without hoods/housings

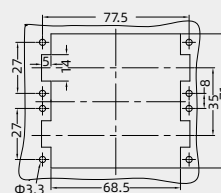

# HVE-020 High voltage inserts

830V 16A 20+4+ 

ERC

## Inserts

Hoods/Housings: size 48B, please find the details on page 15-160~15-162.

Spring terminal, See P00-14 for the structural characteristics of spring.



Insert	Designation	Order No.
Male	HVE-010-MS	124 010 012 0001
	HVE-010-MS(11-20)	124 010 012 0002
Female	HVE-010-FS	124 010 022 0001
	HVE-010-FS(11-20)	124 010 022 0002

1) Distance for contact max. 21 mm

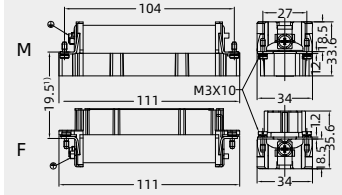

Contact arrangement view from termination side

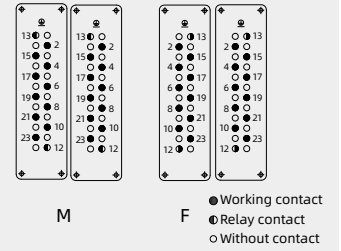

Panel cut out for inserts for use without hoods/housings

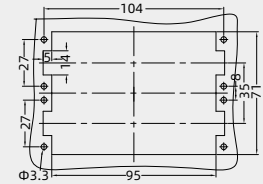



# HEE SERIES

High density connector

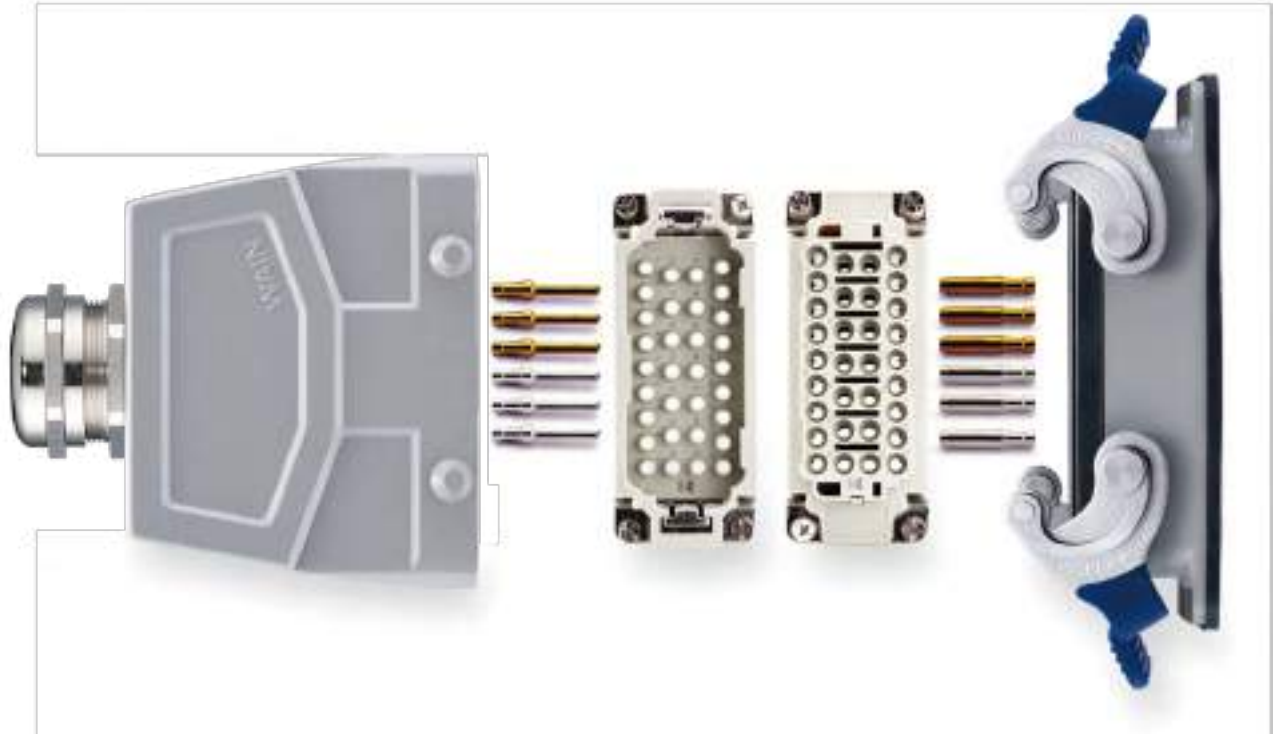



# HEE SERIES High density inserts

## Technical characteristics

Specifications	DIN EN 60 664 DIN EN 61 984
Approvals	
<b>Inserts</b>	
Number of contacts	10,18,32,40,46,64,64(2x32), 92(2x46)+PE
<b>Electrical data acc. to EN 61 984</b>	
-Rated current	16A
-Rated voltage	500V
-Rated impulse voltage	6kV
-Pollution degree	3
-Pollution degree 2 also	16A 830V 8kV 2
Rated voltage acc. to UL/CSA	600V
Insulation resistance	$\geq 10^{10}\Omega$
Material	polycarbonate
Limiting temperatures	-40°C ...+125°C
Flammability acc. to UL 94	V0
Mechanical working life(mating cycles)	$\geq 500$
<b>Contacts</b>	
Material	copper alloy
Surface	hard-gold plated hard-silver plated
<b>Crimp terminal</b>	
-Wire gauge	0.14-4.0mm <sup>2</sup>
-AWG	26-12
-Stripping length	7.5mm
-Contact resistance	$\leq 1m\Omega$
<b>Spring terminal(Quick-in)</b>	
-Wire gauge	0.5-2.5mm <sup>2</sup>
-AWG	20-14
-Stripping length	10 $\pm$ 0.5mm
-Contact resistance	$\leq 3m\Omega$

## Current carrying capacity

The current carrying is limited by maximum temperature of materials for inserts and contacts including terminals

Control and test procedures according to DIN EN 60512-5

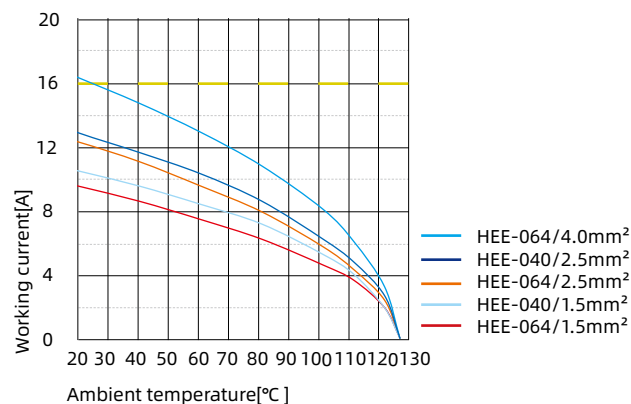
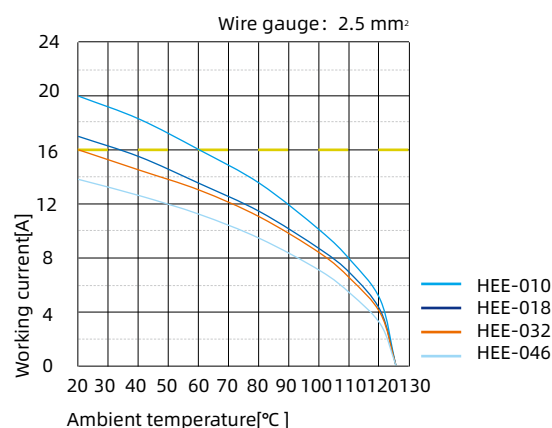
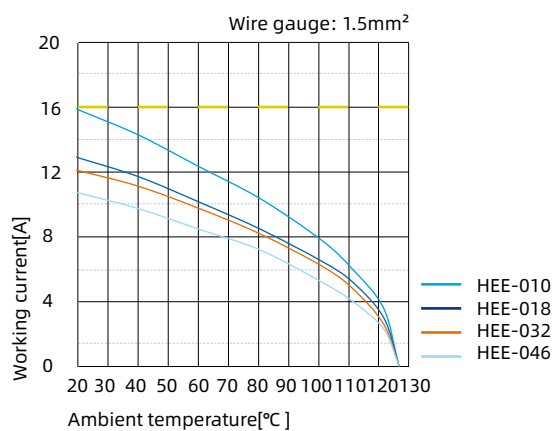

## HEE Modified contact arrangement up to 1000 V

The connector series HEE equipped with all contacts may be used for voltages up to 500 V~ pollution degree 3. A modified contact loading arrangement permits use up to 1000 V~ pollution degree 3 also in pollution degree C. Fully equipped connectors may also be used up to 1000 V~ but in a lower pollution degree. According to DIN EN 61 984 connectors should not be coupled or decoupled under electrical load.

### Contact arrangement view from termination side

690 V Pollution degree 3

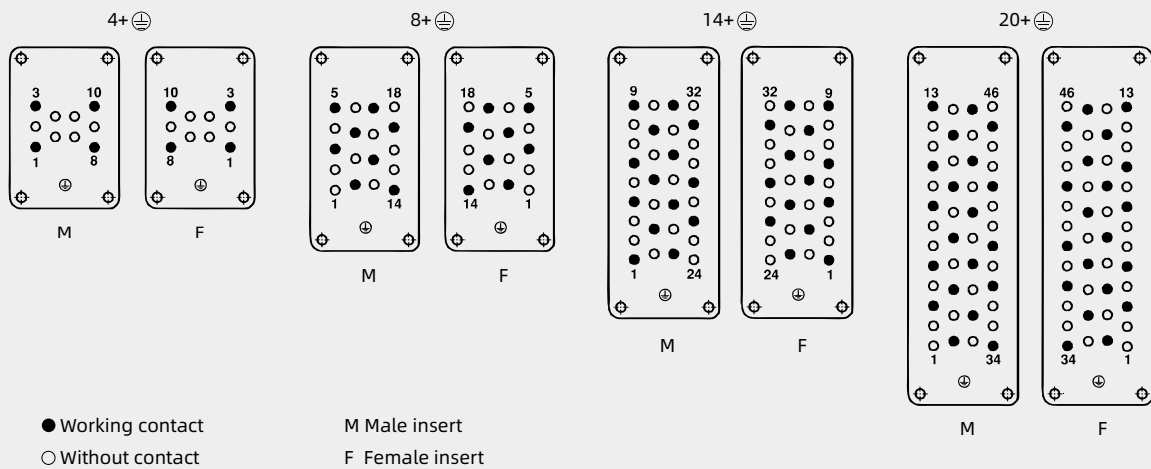

### Contact arrangement view from termination side

1000 V Pollution degree 3

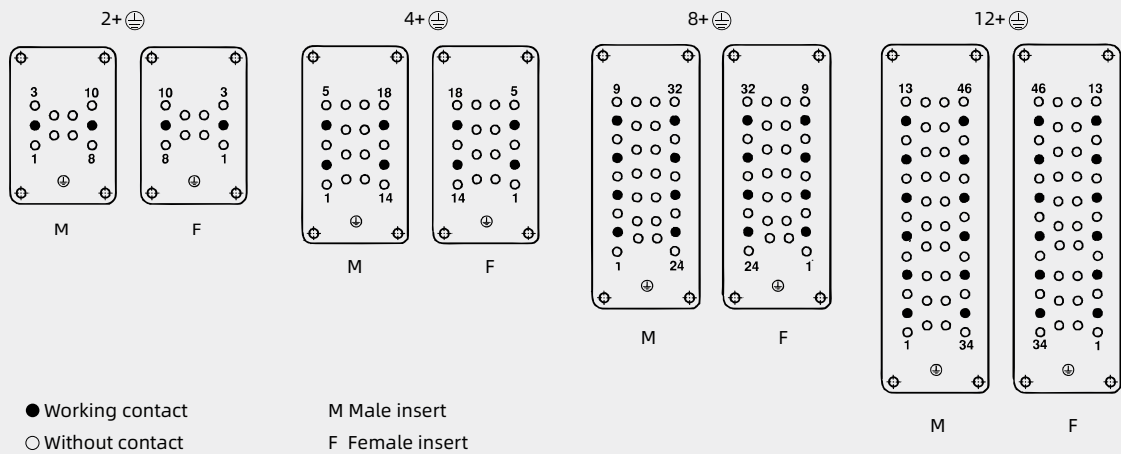

HEE-010 High density inserts

500V 16A 10+



Inserts

Hoods/Housings: size 6B, please find the details on page 15-25~15-38.2.

Crimp terminal

order crimp contacts separately



Insert	Designation	Order No.
Male	HEE-010-MC	123 010 010 0001
Female	HEE-010-FC	123 010 020 0001

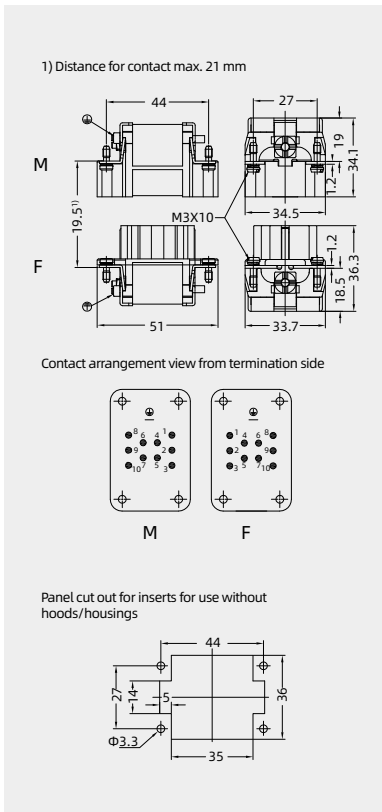

Crimp contacts

Crimp contacts 16A

Contact resistance ≤ 1mΩ silver plated



gold plated



Male	Order No.	Female	Order No.
CESM-0.37	101 019 110 0301	CESF-0.37	101 019 120 0301
CESM-0.50	101 019 110 0401	CESF-0.50	101 019 120 0401
CESM-0.75	101 019 110 0601	CESF-0.75	101 019 120 0601
CESM-1.0	101 019 110 0801	CESF-1.0	101 019 120 0801
CESM-1.5	101 019 110 0901	CESF-1.5	101 019 120 0901
CESM-2.5	101 019 110 1001	CESF-2.5	101 019 120 1001
CESM-3.0	101 019 110 1101	CESF-3.0	101 019 120 1101
CESM-4.0	101 019 110 1201	CESF-4.0	101 019 120 1201
CEGM-0.37	101 019 210 0301	CEGF-0.37	101 019 220 0301
CEGM-0.50	101 019 210 0401	CEGF-0.50	101 019 220 0401
CEGM-0.75	101 019 210 0601	CEGF-0.75	101 019 220 0601
CEGM-1.0	101 019 210 0801	CEGF-1.0	101 019 220 0801
CEGM-1.5	101 019 210 0901	CEGF-1.5	101 019 220 0901
CEGM-2.5	101 019 210 1001	CEGF-2.5	101 019 220 1001
CEGM-3.0	101 019 210 1101	CEGF-3.0	101 019 220 1101
CEGM-4.0	101 019 210 1201	CEGF-4.0	101 019 220 1201

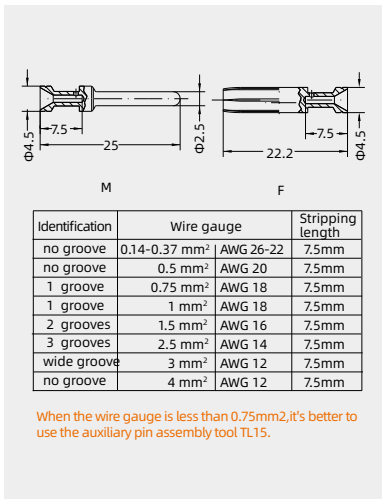

More crimp contacts 16A see P13-04.

Tools

Crimping tool



Contact removal tool



Wire gauge	Designation	Order No.
0.14-4mm <sup>2</sup>	TL02G	198 001 001 0011
Wire gauge: 0.14-0.37mm <sup>2</sup> please select TL02 Crimping tool.		
Application	Designation	Order No.
for crimp contacts 16A	TL01	198 001 000 0002
More tools detail please find the page 32-03-32-06.		

Notes: The tools for crimp terminal may influence the product quality and stability. Please select the tools recognized by our company.

## HEE-018 High density inserts

500V 16A 18+ 

## Inserts

Hoods/Housings: size 10B, detail please find the page15-39~15-69.

## Crimp terminal

order crimp contacts separately



Insert	Designation	Order No.
Male	HEE-018-MC	123 018 010 0001
Female	HEE-018-FC	123 018 020 0001

1) Distance for contact max. 21 mm

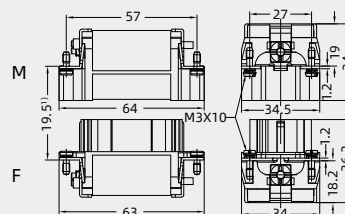

Contact arrangement view from termination side

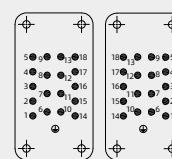

M F

Panel cut out for inserts for use without hoods/housings

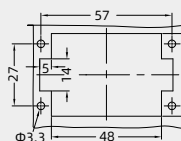

## Crimp contacts

## Crimp contacts 16A

Contact resistance  $\leq 1m\Omega$   
silver plated

gold plated



Male	Order No.	Female	Order No.
CESM-0.37	101 019 110 0301	CESF-0.37	101 019 120 0301
CESM-0.50	101 019 110 0401	CESF-0.50	101 019 120 0401
CESM-0.75	101 019 110 0601	CESF-0.75	101 019 120 0601
CESM-1.0	101 019 110 0801	CESF-1.0	101 019 120 0801
CESM-1.5	101 019 110 0901	CESF-1.5	101 019 120 0901
CESM-2.5	101 019 110 1001	CESF-2.5	101 019 120 1001
CESM-3.0	101 019 110 1101	CESF-3.0	101 019 120 1101
CESM-4.0	101 019 110 1201	CESF-4.0	101 019 120 1201

Male	Order No.	Female	Order No.
CEGM-0.37	101 019 210 0301	CEGF-0.37	101 019 220 0301
CEGM-0.50	101 019 210 0401	CEGF-0.50	101 019 220 0401
CEGM-0.75	101 019 210 0601	CEGF-0.75	101 019 220 0601
CEGM-1.0	101 019 210 0801	CEGF-1.0	101 019 220 0801
CEGM-1.5	101 019 210 0901	CEGF-1.5	101 019 220 0901
CEGM-2.5	101 019 210 1001	CEGF-2.5	101 019 220 1001
CEGM-3.0	101 019 210 1101	CEGF-3.0	101 019 220 1101
CEGM-4.0	101 019 210 1201	CEGF-4.0	101 019 220 1201

More crimp contacts 16A see P13-04.

## Tools

## Crimping tool



## Contact removal tool



Wire gauge	Designation	Order No.
0.14-4mm <sup>2</sup>	TL02G	198 001 001 0011

Wire gauge: 0.14-0.37mm<sup>2</sup> please select TL02 Crimping tool.

Application	Designation	Order No.
for crimp contacts 16A	TL01	198 001 000 0002

More tools detail please find the page32-03~32-06.

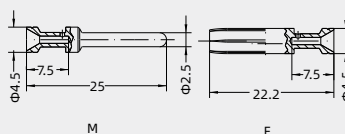

Identification	Wire gauge	Stripping length
no groove	0.14-0.37 mm <sup>2</sup>   AWG 26-22	7.5mm
no groove	0.5 mm <sup>2</sup>   AWG 20	7.5mm
1 groove	0.75 mm <sup>2</sup>   AWG 18	7.5mm
1 groove	1 mm <sup>2</sup>   AWG 18	7.5mm
2 grooves	1.5 mm <sup>2</sup>   AWG 16	7.5mm
3 grooves	2.5 mm <sup>2</sup>   AWG 14	7.5mm
wide groove	3 mm <sup>2</sup>   AWG 12	7.5mm
no groove	4 mm <sup>2</sup>   AWG 12	7.5mm

When the wire gauge is less than 0.75mm<sup>2</sup>, it's better to use the auxiliary pin assembly tool TL15.

Notes: The tools for crimp terminal may influence the product quality and stability. Please select the tools recognized by our company.

## HEE-032 High density inserts

500V 16A 32+ 

## Inserts

Hoods/Housings: size 16B, please find the details on page 15-70~15-1071.

## Crimp terminal

order crimp contacts separately



Insert	Designation	Order No.
Male	HEE-032-MC	123 032 010 0001
Female	HEE-032-FC	123 032 020 0001

1) Distance for contact max. 21 mm

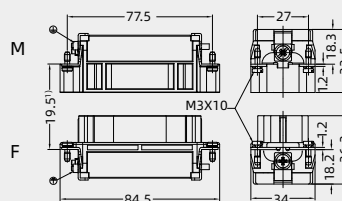

Contact arrangement view from termination side

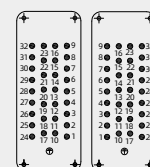

M F

Panel cut out for inserts for use without hoods/housings

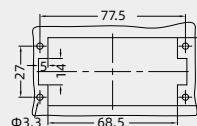

## Crimp contacts

## Crimp contacts 16A

Contact resistance  $\leq 1\text{m}\Omega$   
silver plated

gold plated



More crimp contacts 16A see P13-04.

## Tools

## Crimping tool



## Contact removal tool



Male	Order No.	Female	Order No.
CESM-0.37	101 019 110 0301	CESF-0.37	101 019 120 0301
CESM-0.50	101 019 110 0401	CESF-0.50	101 019 120 0401
CESM-0.75	101 019 110 0601	CESF-0.75	101 019 120 0601
CESM-1.0	101 019 110 0801	CESF-1.0	101 019 120 0801
CESM-1.5	101 019 110 0901	CESF-1.5	101 019 120 0901
CESM-2.5	101 019 110 1001	CESF-2.5	101 019 120 1001
CESM-3.0	101 019 110 1101	CESF-3.0	101 019 120 1101
CESM-4.0	101 019 110 1201	CESF-4.0	101 019 120 1201
CEGM-0.37	101 019 210 0301	CEGF-0.37	101 019 220 0301
CEGM-0.50	101 019 210 0401	CEGF-0.50	101 019 220 0401
CEGM-0.75	101 019 210 0601	CEGF-0.75	101 019 220 0601
CEGM-1.0	101 019 210 0801	CEGF-1.0	101 019 220 0801
CEGM-1.5	101 019 210 0901	CEGF-1.5	101 019 220 0901
CEGM-2.5	101 019 210 1001	CEGF-2.5	101 019 220 1001
CEGM-3.0	101 019 210 1101	CEGF-3.0	101 019 220 1101
CEGM-4.0	101 019 210 1201	CEGF-4.0	101 019 220 1201

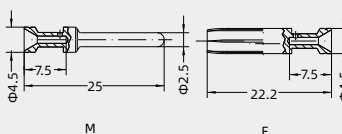

Identification	Wire gauge	Stripping length
no groove	0.14-0.37 mm <sup>2</sup>   AWG 26-22	7.5mm
no groove	0.5 mm <sup>2</sup>   AWG 20	7.5mm
1 groove	0.75 mm <sup>2</sup>   AWG 18	7.5mm
1 groove	1 mm <sup>2</sup>   AWG 18	7.5mm
2 grooves	1.5 mm <sup>2</sup>   AWG 16	7.5mm
3 grooves	2.5 mm <sup>2</sup>   AWG 14	7.5mm
wide groove	3 mm <sup>2</sup>   AWG 12	7.5mm
no groove	4 mm <sup>2</sup>   AWG 12	7.5mm

When the wire gauge is less than 0.75mm<sup>2</sup>, it's better to use the auxiliary pin assembly tool TL15.

Wire gauge	Designation	Order No.
0.14-4mm <sup>2</sup>	TL02G	198 001 001 0011
Wire gauge: 0.14-0.37mm <sup>2</sup> please select TL02 Crimping tool.		
Application	Designation	Order No.
for crimp contacts 16A	TL01	198 001 000 0002

More tools detail please find the page 32-03-32-06.

Notes: The tools for crimp terminal may influence the product quality and stability. Please select the tools recognized by our company.

## HEE-032 Quick-in Module

500V 16A 32+ Inserts 

Hoods/Housings: size 16B, please find the details on page 15-70~15-1071.

Spring terminal (Quick-in)



Insert	Designation	Order No.
Male	HEE-032-MQ	123 032 001 0500
Female	HEE-032-FQ	123 032 002 0500

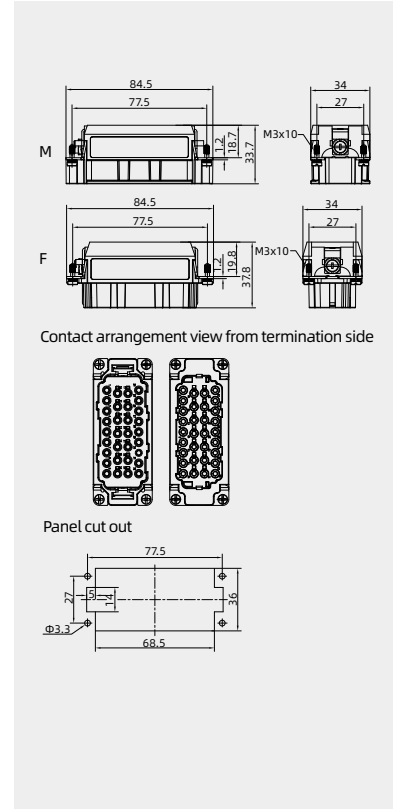

# HEE-046 High density inserts

500V 16A 46+



## Inserts

Hoods/Housings: size 24B, please find the details on page 15-108~15-150.

### Crimp terminal

order crimp contacts separately



Insert	Designation	Order No.
Male	HEE-046-MC	123 046 010 0011
Female	HEE-046-FC	123 046 020 0011
Male	HEE-046-MC/N <sup>2)</sup>	123 046 010 0101
Female	HEE-046-FC/N <sup>2)</sup>	123 046 020 0101

2) for crimp contacts 16A-Enhanced III, see page 13-04.

1) Distance for contact max. 21 mm

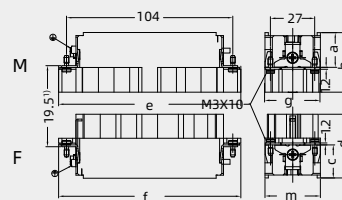

	a	b	e	g	c	d	f	m
M/F	18.5	33.8	110.5	34.4	18.3	36.2	110	34.4
MC/FC	18.3	33.8	110	34.4	18.2	36.2	110	34.4

Contact arrangement view from termination side

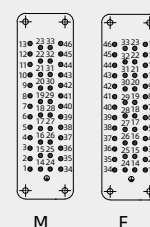

Panel cut out for inserts for use without hoods/housings

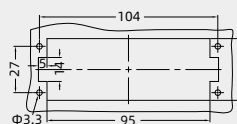

## Crimp contacts

### Crimp contacts 16A

Contact resistance ≤ 1mΩ  
silver plated



gold plated



Male	Order No.	Female	Order No.
CESM-0.37	101 019 110 0301	CESF-0.37	101 019 120 0301
CESM-0.50	101 019 110 0401	CESF-0.50	101 019 120 0401
CESM-0.75	101 019 110 0601	CESF-0.75	101 019 120 0601
CESM-1.0	101 019 110 0801	CESF-1.0	101 019 120 0801
CESM-1.5	101 019 110 0901	CESF-1.5	101 019 120 0901
CESM-2.5	101 019 110 1001	CESF-2.5	101 019 120 1001
CESM-3.0	101 019 110 1101	CESF-3.0	101 019 120 1101
CESM-4.0	101 019 110 1201	CESF-4.0	101 019 120 1201
CEGM-0.37	101 019 210 0301	CEGF-0.37	101 019 220 0301
CEGM-0.50	101 019 210 0401	CEGF-0.50	101 019 220 0401
CEGM-0.75	101 019 210 0601	CEGF-0.75	101 019 220 0601
CEGM-1.0	101 019 210 0801	CEGF-1.0	101 019 220 0801
CEGM-1.5	101 019 210 0901	CEGF-1.5	101 019 220 0901
CEGM-2.5	101 019 210 1001	CEGF-2.5	101 019 220 1001
CEGM-3.0	101 019 210 1101	CEGF-3.0	101 019 220 1101
CEGM-4.0	101 019 210 1201	CEGF-4.0	101 019 220 1201

More crimp contacts 16A see P13-04.

### Tools

Crimping tool



Contact removal tool



Wire gauge	Designation	Order No.
0.14-4mm <sup>2</sup>	TL02G	198 001 001 0011
Wire gauge: 0.14-0.37mm <sup>2</sup> please select TL02 Crimping tool.		
Application	Designation	Order No.
for crimp contacts 16A	TL01	198 001 000 0002

More tools detail please find the page 32-03~32-06.

Identification	Wire gauge	Stripping length
no groove	0.14-0.37 mm <sup>2</sup>   AWG 26-22	7.5mm
no groove	0.5 mm <sup>2</sup>   AWG 20	7.5mm
1 groove	0.75 mm <sup>2</sup>   AWG 18	7.5mm
1 groove	1 mm <sup>2</sup>   AWG 18	7.5mm
2 grooves	1.5 mm <sup>2</sup>   AWG 16	7.5mm
3 grooves	2.5 mm <sup>2</sup>   AWG 14	7.5mm
wide groove	3 mm <sup>2</sup>   AWG 12	7.5mm
no groove	4 mm <sup>2</sup>   AWG 12	7.5mm

When the wire gauge is less than 0.75mm<sup>2</sup>, it's better to use the auxiliary pin assembly tool TL15.

Notes: The tools for crimp terminal may influence the product quality and stability. Please select the tools recognized by our company.

# HEE-046 Quick-in Module

500V 16A 46+ 

## Inserts

Hoods/Housings: size 24B, please find the details on page 15-108~15-150.

### Spring terminal (Quick-in)



Insert	Designation	Order No.
Male	HEE-046-MQ	123 046 001 0001
Female	HEE-046-FQ	123 046 002 0001

1) Distance for contact max. 21 mm

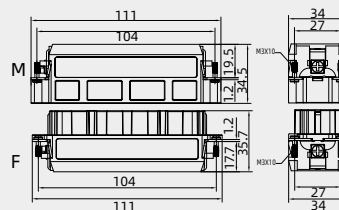

Contact arrangement view from termination side

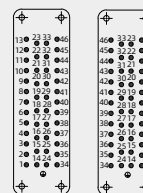

M F

Panel cut out for inserts for use without hoods/housings

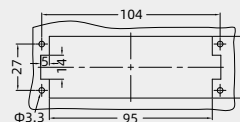

### Coding element



Description	Designation	Order No.
coding, pokayoke	CODE-I	198 002 005 0035

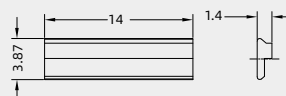



# HEE-032x2 High density inserts

500V 16A 64+



## Inserts

Hoods/Housings: size 32B, please find the details on page 15-151~15-159.

Crimp terminal  
order crimp contacts separately



Insert	Designation	Order No.
Male	HEE-032-MC	123 032 010 0001
	HEE-032-MC(33-64)	123 032 010 0002
Female	HEE-032-FC	123 032 020 0001
	HEE-032-FC(33-64)	123 032 020 0002

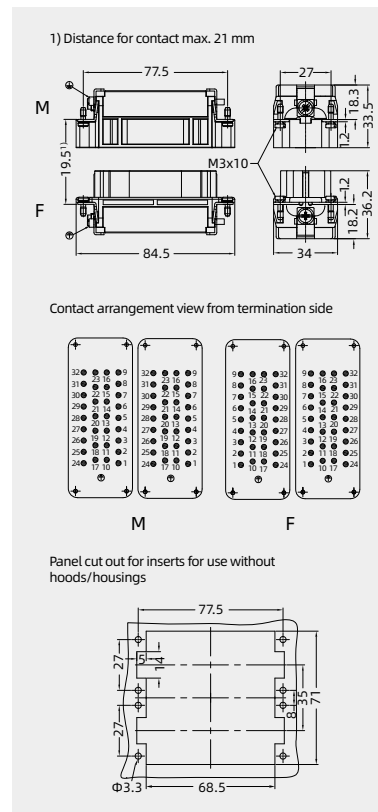

## Crimp contacts

### Crimp contacts 16A

Contact resistance  $\leq 1m\Omega$   
silver plated



gold plated



Male	Order No.	Female	Order No.
CESM-0.37	101 019 110 0301	CESF-0.37	101 019 120 0301
CESM-0.50	101 019 110 0401	CESF-0.50	101 019 120 0401
CESM-0.75	101 019 110 0601	CESF-0.75	101 019 120 0601
CESM-1.0	101 019 110 0801	CESF-1.0	101 019 120 0801
CESM-1.5	101 019 110 0901	CESF-1.5	101 019 120 0901
CESM-2.5	101 019 110 1001	CESF-2.5	101 019 120 1001
CESM-3.0	101 019 110 1101	CESF-3.0	101 019 120 1101
CESM-4.0	101 019 110 1201	CESF-4.0	101 019 120 1201
CEGM-0.37	101 019 210 0301	CEGF-0.37	101 019 220 0301
CEGM-0.50	101 019 210 0401	CEGF-0.50	101 019 220 0401
CEGM-0.75	101 019 210 0601	CEGF-0.75	101 019 220 0601
CEGM-1.0	101 019 210 0801	CEGF-1.0	101 019 220 0801
CEGM-1.5	101 019 210 0901	CEGF-1.5	101 019 220 0901
CEGM-2.5	101 019 210 1001	CEGF-2.5	101 019 220 1001
CEGM-3.0	101 019 210 1101	CEGF-3.0	101 019 220 1101
CEGM-4.0	101 019 210 1201	CEGF-4.0	101 019 220 1201

More crimp contacts 16A see P13-04.

### Tools

Crimping tool



Contact removal tool



Wire gauge	Designation	Order No.
0.14-4mm <sup>2</sup>	TL02G	198 001 001 0011
Wire gauge: 0.14-0.37mm <sup>2</sup> please select TL02 Crimping tool.		
Application	Designation	Order No.
for crimp contacts 16A	TL01	198 001 000 0002
More tools detail please find the page 32-03~32-06.		

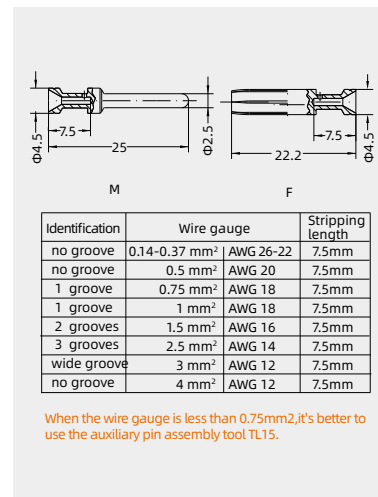

Notes: The tools for crimp terminal may influence the product quality and stability. Please select the tools recognized by our company.

HEE-092 High density inserts

500V 16A 92+ Ⓢ

Inserts

Hoods/Housings: size 48B, please find the details on page 15-160~15-162.

Crimp terminal

order crimp contacts separately



Insert	Designation	Order No.
Male	HEE-046-MC	123 046 010 0011
	HEE-046-MC(47-92)	123 046 010 0012
Female	HEE-046-FC	123 046 020 0011
	HEE-046-FC(47-92)	123 046 020 0012
Male	HEE-046-MC/N <sup>2)</sup>	123 046 010 0101
	HEE-046-MC/N(47-92) <sup>2)</sup>	123 046 010 0102
Female	HEE-046-FC/N <sup>2)</sup>	123 046 020 0101
	HEE-046-FC/N(47-92) <sup>2)</sup>	123 046 020 0102

2).for crimp contacts 16A-Enhanced III ,see page 13-04.

1) Distance for contact max. 21 mm

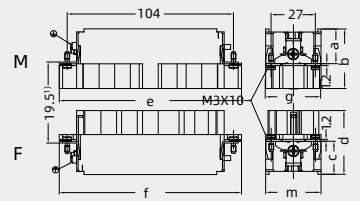

	a	b	e	g	c	d	f	m
M/F	18.5	33.8	110.5	34.4	18.3	36.2	110	34.4
MC/FC	18.3	33.8	110	34.4	18.2	36.2	110	34.4

Contact arrangement view from termination side

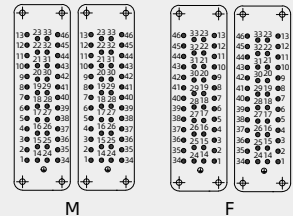

Panel cut out for inserts for use without hoods/housings

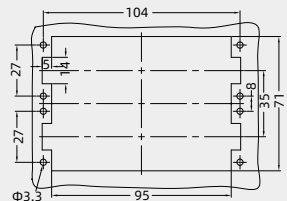

Crimp contacts

Crimp contacts 16A

Contact resistance ≤ 1mΩ silver plated



gold plated



Male	Order No.	Female	Order No.
CESM-0.37	101 019 110 0301	CESF-0.37	101 019 120 0301
CESM-0.50	101 019 110 0401	CESF-0.50	101 019 120 0401
CESM-0.75	101 019 110 0601	CESF-0.75	101 019 120 0601
CESM-1.0	101 019 110 0801	CESF-1.0	101 019 120 0801
CESM-1.5	101 019 110 0901	CESF-1.5	101 019 120 0901
CESM-2.5	101 019 110 1001	CESF-2.5	101 019 120 1001
CESM-3.0	101 019 110 1101	CESF-3.0	101 019 120 1101
CESM-4.0	101 019 110 1201	CESF-4.0	101 019 120 1201
CEGM-0.37	101 019 210 0301	CEGF-0.37	101 019 220 0301
CEGM-0.50	101 019 210 0401	CEGF-0.50	101 019 220 0401
CEGM-0.75	101 019 210 0601	CEGF-0.75	101 019 220 0601
CEGM-1.0	101 019 210 0801	CEGF-1.0	101 019 220 0801
CEGM-1.5	101 019 210 0901	CEGF-1.5	101 019 220 0901
CEGM-2.5	101 019 210 1001	CEGF-2.5	101 019 220 1001
CEGM-3.0	101 019 210 1101	CEGF-3.0	101 019 220 1101
CEGM-4.0	101 019 210 1201	CEGF-4.0	101 019 220 1201

More crimp contacts 16A see P13-04.

Tools

Crimping tool



Contact removal tool



Wire gauge	Designation	Order No.
0.14-4mm <sup>2</sup>	TL02G	198 001 001 0011
Wire gauge: 0.14-0.37mm <sup>2</sup> please select TL02 Crimping tool.		
Application	Designation	Order No.
for crimp contacts 16A	TL01	198 001 000 0002

More tools detail please find the page 32-03-32-06.

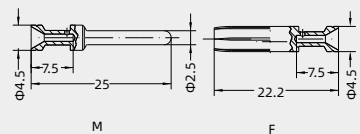

Identification	Wire gauge	Stripping length
no groove	0.14-0.37 mm <sup>2</sup> AWG 26-22	7.5mm
no groove	0.5 mm <sup>2</sup> AWG 20	7.5mm
1 groove	0.75 mm <sup>2</sup> AWG 18	7.5mm
1 groove	1 mm <sup>2</sup> AWG 18	7.5mm
2 grooves	1.5 mm <sup>2</sup> AWG 16	7.5mm
3 grooves	2.5 mm <sup>2</sup> AWG 14	7.5mm
wide groove	3 mm <sup>2</sup> AWG 12	7.5mm
no groove	4 mm <sup>2</sup> AWG 12	7.5mm

When the wire gauge is less than 0.75mm<sup>2</sup>, it's better to use the auxiliary pin assembly tool TL15.

Notes: The tools for crimp terminal may influence the product quality and stability. Please select the tools recognized by our company.

## HEE-040 High density inserts

500V 16A 40+ 

## Inserts

Hoods/Housings: size 16B, please find the details on page 15-70~15-1071.

## Crimp terminal

order crimp contacts separately



Insert	Designation	Order No.
Male	HEE-040-MC	123 040 010 0001
Female	HEE-040-FC	123 040 020 0001

1) Distance for contact max. 21 mm

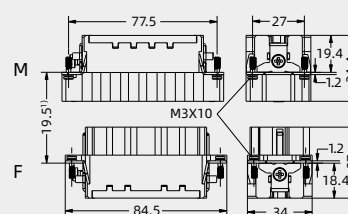

Contact arrangement view from termination side

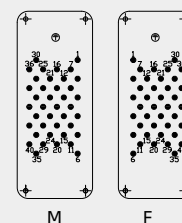

Panel cut out for inserts for use without hoods/housings

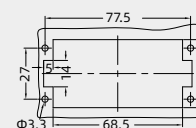

## Crimp contacts

## Crimp contacts 16A

Contact resistance  $\leq 1m\Omega$   
silver plated

gold plated



More crimp contacts 16A see P13-04.

## Tools

Crimping tool



Contact removal tool



Male	Order No.	Female	Order No.
CESM-0.37	101 019 110 0301	CESF-0.37	101 019 120 0301
CESM-0.50	101 019 110 0401	CESF-0.50	101 019 120 0401
CESM-0.75	101 019 110 0601	CESF-0.75	101 019 120 0601
CESM-1.0	101 019 110 0801	CESF-1.0	101 019 120 0801
CESM-1.5	101 019 110 0901	CESF-1.5	101 019 120 0901
CESM-2.5	101 019 110 1001	CESF-2.5	101 019 120 1001
CESM-3.0	101 019 110 1101	CESF-3.0	101 019 120 1101
CESM-4.0	101 019 110 1201	CESF-4.0	101 019 120 1201
CEGM-0.37	101 019 210 0301	CEGF-0.37	101 019 220 0301
CEGM-0.50	101 019 210 0401	CEGF-0.50	101 019 220 0401
CEGM-0.75	101 019 210 0601	CEGF-0.75	101 019 220 0601
CEGM-1.0	101 019 210 0801	CEGF-1.0	101 019 220 0801
CEGM-1.5	101 019 210 0901	CEGF-1.5	101 019 220 0901
CEGM-2.5	101 019 210 1001	CEGF-2.5	101 019 220 1001
CEGM-3.0	101 019 210 1101	CEGF-3.0	101 019 220 1101
CEGM-4.0	101 019 210 1201	CEGF-4.0	101 019 220 1201

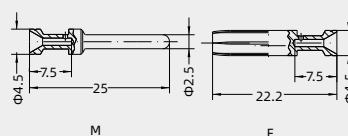

Identification	Wire gauge	Stripping length
no groove	0.14-0.37 mm <sup>2</sup> AWG 26-22	7.5mm
no groove	0.5 mm <sup>2</sup> AWG 20	7.5mm
1 groove	0.75 mm <sup>2</sup> AWG 18	7.5mm
1 groove	1 mm <sup>2</sup> AWG 18	7.5mm
2 grooves	1.5 mm <sup>2</sup> AWG 16	7.5mm
3 grooves	2.5 mm <sup>2</sup> AWG 14	7.5mm
wide groove	3 mm <sup>2</sup> AWG 12	7.5mm
no groove	4 mm <sup>2</sup> AWG 12	7.5mm

When the wire gauge is less than 0.75mm<sup>2</sup>, it's better to use the auxiliary pin assembly tool TL15.

Wire gauge	Designation	Order No.
0.14-4mm <sup>2</sup>	TL02G	198 001 001 0011
Wire gauge: 0.14-0.37mm <sup>2</sup> please select TL02 Crimping tool.		
Application	Designation	Order No.
for crimp contacts 16A	TL01	198 001 000 0002

More tools detail please find the page 32-03~32-06.

Notes: The tools for crimp terminal may influence the product quality and stability. Please select the tools recognized by our company.

# HEE-064 High density inserts

500V 16A 64+ 

## Inserts

Hoods/Housings: size 24B, please find the details on page 15-108~15-150.

### Crimp terminal

order crimp contacts separately



Insert	Designation	Order No.
Male	HEE-064-MC	123 064 010 0001
Female	HEE-064-FC	123 064 020 0001

1) Distance for contact max. 21 mm

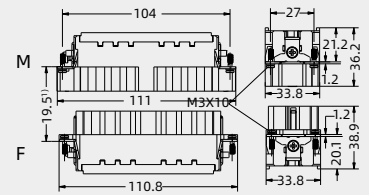

Contact arrangement view from termination side

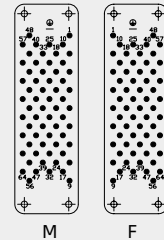

Panel cut out for inserts for use without hoods/housings

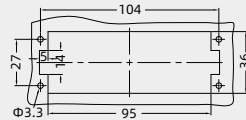

## Crimp contacts

### Crimp contacts 16A

Contact resistance ≤ 1mΩ  
silver plated



gold plated



Male	Order No.	Female	Order No.
CESM-0.37	101 019 110 0301	CESF-0.37	101 019 120 0301
CESM-0.50	101 019 110 0401	CESF-0.50	101 019 120 0401
CESM-0.75	101 019 110 0601	CESF-0.75	101 019 120 0601
CESM-1.0	101 019 110 0801	CESF-1.0	101 019 120 0801
CESM-1.5	101 019 110 0901	CESF-1.5	101 019 120 0901
CESM-2.5	101 019 110 1001	CESF-2.5	101 019 120 1001
CESM-3.0	101 019 110 1101	CESF-3.0	101 019 120 1101
CESM-4.0	101 019 110 1201	CESF-4.0	101 019 120 1201
CEGM-0.37	101 019 210 0301	CEGF-0.37	101 019 220 0301
CEGM-0.50	101 019 210 0401	CEGF-0.50	101 019 220 0401
CEGM-0.75	101 019 210 0601	CEGF-0.75	101 019 220 0601
CEGM-1.0	101 019 210 0801	CEGF-1.0	101 019 220 0801
CEGM-1.5	101 019 210 0901	CEGF-1.5	101 019 220 0901
CEGM-2.5	101 019 210 1001	CEGF-2.5	101 019 220 1001
CEGM-3.0	101 019 210 1101	CEGF-3.0	101 019 220 1101
CEGM-4.0	101 019 210 1201	CEGF-4.0	101 019 220 1201

More crimp contacts 16A see P13-04.

### Tools

Crimping tool



Contact removal tool



Wire gauge	Designation	Order No.
0.14-4mm <sup>2</sup>	TL02G	198 001 001 0011
Wire gauge: 0.14-0.37mm <sup>2</sup> please select TL02 Crimping tool.		
Application	Designation	Order No.
for crimp contacts 16A	TL01	198 001 000 0002
More tools detail please find the page 32-03-32-06.		

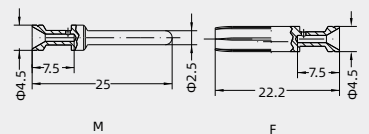

Identification	Wire gauge	Stripping length
no groove	0.14-0.37 mm <sup>2</sup>   AWG 26-22	7.5mm
no groove	0.5 mm <sup>2</sup>   AWG 20	7.5mm
1 groove	0.75 mm <sup>2</sup>   AWG 18	7.5mm
1 groove	1 mm <sup>2</sup>   AWG 18	7.5mm
2 grooves	1.5 mm <sup>2</sup>   AWG 16	7.5mm
3 grooves	2.5 mm <sup>2</sup>   AWG 14	7.5mm
wide groove	3 mm <sup>2</sup>   AWG 12	7.5mm
no groove	4 mm <sup>2</sup>   AWG 12	7.5mm

When the wire gauge is less than 0.75mm<sup>2</sup>, it's better to use the auxiliary pin assembly tool TL15.

Notes: The tools for crimp terminal may influence the product quality and stability. Please select the tools recognized by our company.

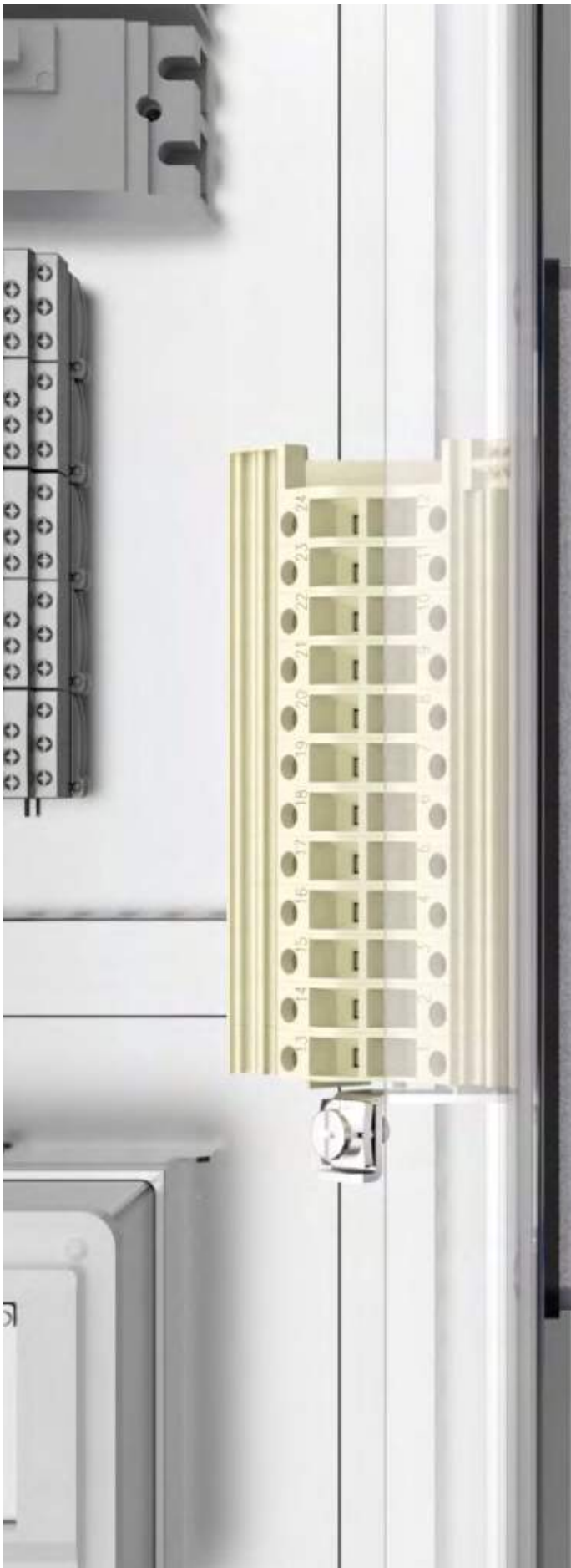

# HEEE SERIES

Ultra high density type insert



## HEEE SERIES ultra high density type insert



### Technical characteristics

Specifications	DIN EN 60 664	DIN EN 61 984
Approvals		
Inserts		
Number of contacts	32+PE,72+PE	
Electrical data acc. to EN 61 984		
-Rated current	16A	
-Rated voltage	400V	
-Rated impulse voltage	6kV	
-Pollution degree	3	
Insulation resistance	$\geq 10^{10}\Omega$	
Material	polycarbonate	
Limiting temperatures	-40°C ...+125°C	
Flammability acc. to UL 94	V0	
Mechanical working life(mating cycles)	$\geq 500$	
Contacts		
Material	copper alloy	
Surface	hard-gold plated hard-silver plated	
Contact resistance	$\leq 1\text{m}\Omega$	
Crimp terminal		
-Wire gauge	0.14-4.0mm <sup>2</sup>	
-AWG	26-12	
-Stripping length	7.5mm	
Tools		
Crimping tool	TL02G(0.5-4mm <sup>2</sup> ) TL02(0.14-0.37mm <sup>2</sup> )	
Contact removal tool	TL01	

# HEEE-032 Ultra high density type insert

400V 16A 32+



## Inserts

Hoods/Housings: size 10B, please find the details on page 15-39~15-69.

### Crimp terminal

order crimp contacts separately



Insert	Designation	Order No.
Male	HEEE-032-MC	136 032 010 0001
Female	HEEE-032-FC	136 032 020 0001

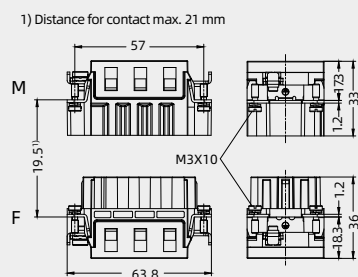

Contact arrangement view from termination side

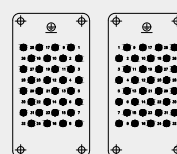

M F

Panel cut out for inserts for use without hoods/housings

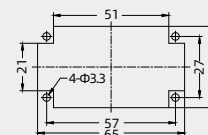

## Crimp contacts

### Crimp contacts 16A

Contact resistance  $\leq 1m\Omega$   
silver plated



gold plated



Male	Order No.	Female	Order No.
CESM-0.37	101 019 110 0301	CESF-0.37	101 019 120 0301
CESM-0.50	101 019 110 0401	CESF-0.50	101 019 120 0401
CESM-0.75	101 019 110 0601	CESF-0.75	101 019 120 0601
CESM-1.0	101 019 110 0801	CESF-1.0	101 019 120 0801
CESM-1.5	101 019 110 0901	CESF-1.5	101 019 120 0901
CESM-2.5	101 019 110 1001	CESF-2.5	101 019 120 1001
CESM-3.0	101 019 110 1101	CESF-3.0	101 019 120 1101
CESM-4.0	101 019 110 1201	CESF-4.0	101 019 120 1201
CEGM-0.37	101 019 210 0301	CEGF-0.37	101 019 220 0301
CEGM-0.50	101 019 210 0401	CEGF-0.50	101 019 220 0401
CEGM-0.75	101 019 210 0601	CEGF-0.75	101 019 220 0601
CEGM-1.0	101 019 210 0801	CEGF-1.0	101 019 220 0801
CEGM-1.5	101 019 210 0901	CEGF-1.5	101 019 220 0901
CEGM-2.5	101 019 210 1001	CEGF-2.5	101 019 220 1001
CEGM-3.0	101 019 210 1101	CEGF-3.0	101 019 220 1101
CEGM-4.0	101 019 210 1201	CEGF-4.0	101 019 220 1201

More crimp contacts 16A see P13-04.

### Tools

Crimping tool



Contact removal tool



Wire gauge	Designation	Order No.
0.14-4mm <sup>2</sup>	TL02G	198 001 001 0011
Wire gauge: 0.14-0.37mm <sup>2</sup> please select TL02 Crimping tool.		
Application	Designation	Order No.
for crimp contacts 16A	TL01	198 001 000 0002
More tools detail please find the page 32-03~32-06.		

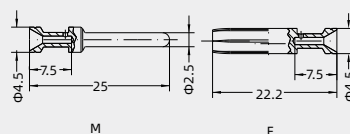

Identification	Wire gauge	Stripping length
no groove	0.14-0.37 mm <sup>2</sup>   AWG 26-22	7.5mm
no groove	0.5 mm <sup>2</sup>   AWG 20	7.5mm
1 groove	0.75 mm <sup>2</sup>   AWG 18	7.5mm
1 groove	1 mm <sup>2</sup>   AWG 18	7.5mm
2 grooves	1.5 mm <sup>2</sup>   AWG 16	7.5mm
3 grooves	2.5 mm <sup>2</sup>   AWG 14	7.5mm
wide groove	3 mm <sup>2</sup>   AWG 12	7.5mm
no groove	4 mm <sup>2</sup>   AWG 12	7.5mm

When the wire gauge is less than 0.75mm<sup>2</sup>, it's better to use the auxiliary pin assembly tool TL15.

Notes: The tools for crimp terminal may influence the product quality and stability. Please select the tools recognized by our company.



# HEEE-072 Ultra high density type insert

400V 16A 72+



## Inserts

Hoods/Housings: size 24B, please find the details on page 15-108~15-150.

**Crimp terminal**  
order crimp contacts separately



Insert	Designation	Order No.
Male	HEEE-072-MC	136 072 010 0001
Female	HEEE-072-FC	136 072 020 0001

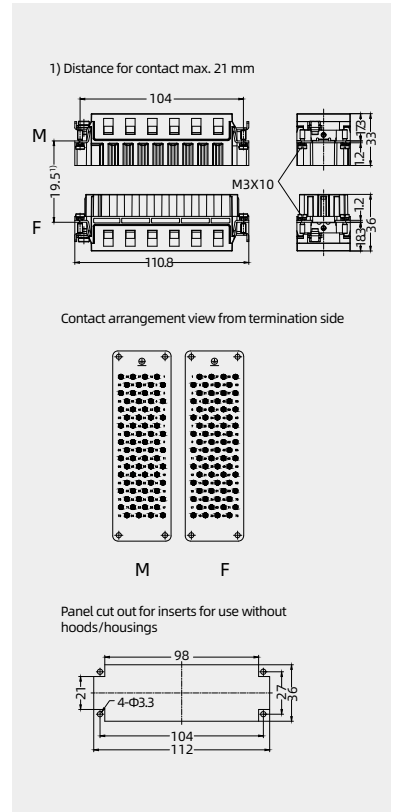

## Crimp contacts

### Crimp contacts 16A

Contact resistance  $\leq 1m\Omega$   
silver plated



gold plated



Male	Order No.	Female	Order No.
CESM-0.37	101 019 110 0301	CESF-0.37	101 019 120 0301
CESM-0.50	101 019 110 0401	CESF-0.50	101 019 120 0401
CESM-0.75	101 019 110 0601	CESF-0.75	101 019 120 0601
CESM-1.0	101 019 110 0801	CESF-1.0	101 019 120 0801
CESM-1.5	101 019 110 0901	CESF-1.5	101 019 120 0901
CESM-2.5	101 019 110 1001	CESF-2.5	101 019 120 1001
CESM-3.0	101 019 110 1101	CESF-3.0	101 019 120 1101
CESM-4.0	101 019 110 1201	CESF-4.0	101 019 120 1201
CEGM-0.37	101 019 210 0301	CEGF-0.37	101 019 220 0301
CEGM-0.50	101 019 210 0401	CEGF-0.50	101 019 220 0401
CEGM-0.75	101 019 210 0601	CEGF-0.75	101 019 220 0601
CEGM-1.0	101 019 210 0801	CEGF-1.0	101 019 220 0801
CEGM-1.5	101 019 210 0901	CEGF-1.5	101 019 220 0901
CEGM-2.5	101 019 210 1001	CEGF-2.5	101 019 220 1001
CEGM-3.0	101 019 210 1101	CEGF-3.0	101 019 220 1101
CEGM-4.0	101 019 210 1201	CEGF-4.0	101 019 220 1201

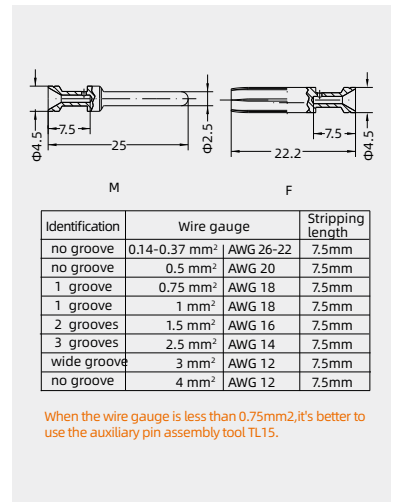

More crimp contacts 16A see P13-04.

### Tools

Crimping tool



Contact removal tool



Wire gauge	Designation	Order No.
0.14-4mm <sup>2</sup>	TL02G	198 001 001 0011
Wire gauge: 0.14-0.37mm <sup>2</sup> please select TL02 Crimping tool.		
Application	Designation	Order No.
for crimp contacts 16A	TL01	198 001 000 0002
More tools detail please find the page 32-03-32-06.		

Notes: The tools for crimp terminal may influence the product quality and stability. Please select the tools recognized by our company.

# HD HDD SERIES

Ultra-high density connector

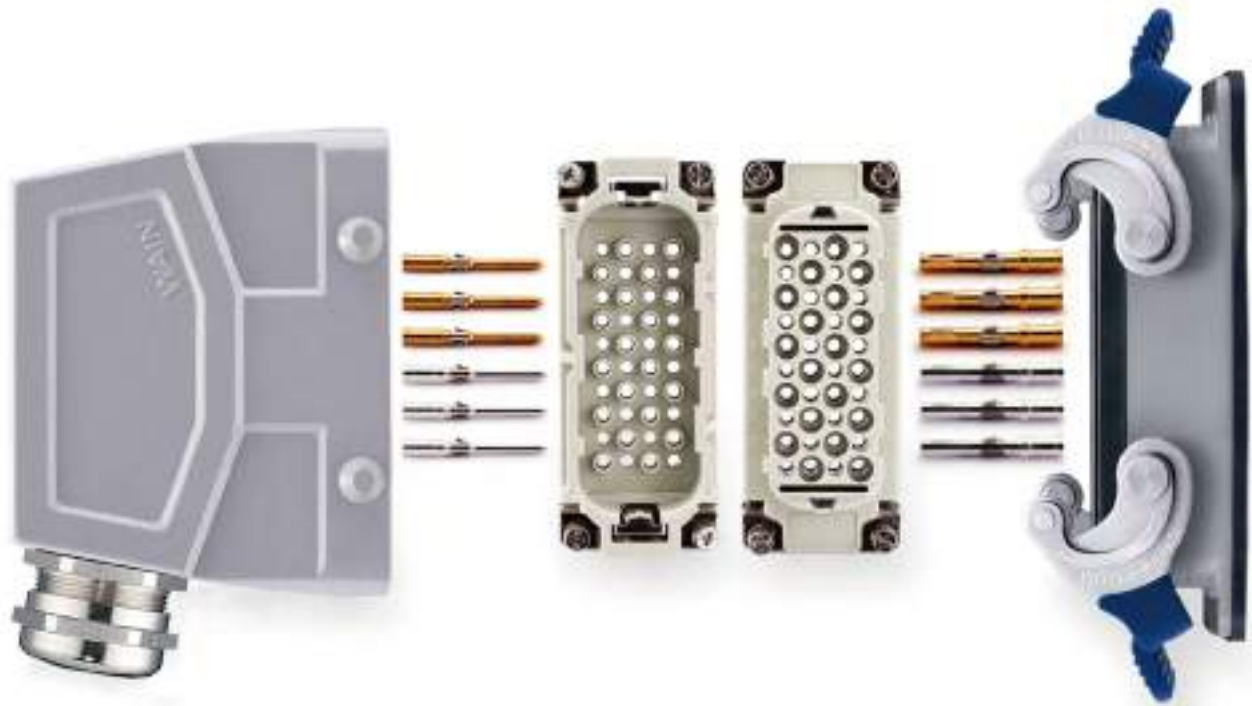

# HD SERIES Ultra-high density inserts

## Technical characteristics

Specifications	DIN EN 60 664 DIN EN 61 984
Approvals	
Inserts	
Number of contacts	7,8,15,25,40,50(25x2),64,80(40x2), 128(64x2)+PE
Electrical data acc. to EN 61 984	
-Rated current	10A
-Rated voltage	250V
-Rated impulse voltage	4kV
-Pollution degree	3
-Pollution degree 2 also	10A 230/400V 4kV 2
-Rated voltage acc. to UL	600V
HD-008 Electrical data	
-Rated current	10A
-Rated voltage	~50V/-120V
-Rated impulse voltage	0.8kV
-Pollution degree	3
-Rated voltage acc. to UL	50V
-Rated voltage(direct voltage)	120V
Insulation resistance	$\geq 10^{10}\Omega$
Material	polycarbonate
Limiting temperatures	-40°C ...+125°C
Flammability acc. to UL 94	V0
Mechanical working life(mating cycles)	$\geq 500$
<b>Contacts</b>	
Material	copper alloy
Surface	hard-gold plated hard-silver plated
Contact resistance	$\leq 3m\Omega$
Crimp terminal	
-Wire gauge	0.14-2.5mm <sup>2</sup>
-AWG	26-14
<b>Stamped contacts</b>	
Material	copper alloy
Surface	hard-silver plated
Contact resistance	$\leq 5m\Omega$
Crimp terminal	
-Wire gauge	0.5-1.5mm <sup>2</sup> /1.5-2.5mm <sup>2</sup>
-AWG	20-16/16-14
-Stripping length	6mm

## Current carrying capacity

The current carrying is limited by maximum temperature of materials for inserts and contacts including terminals

Control and test procedures according to DIN EN 60512-5

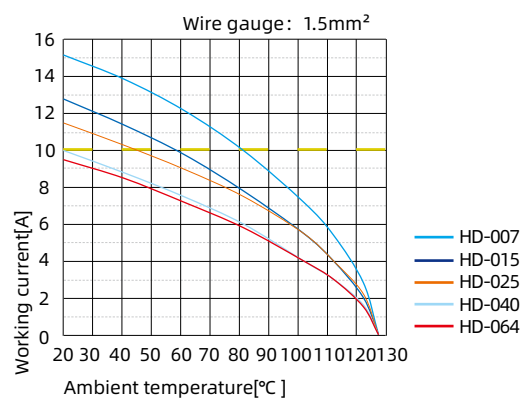
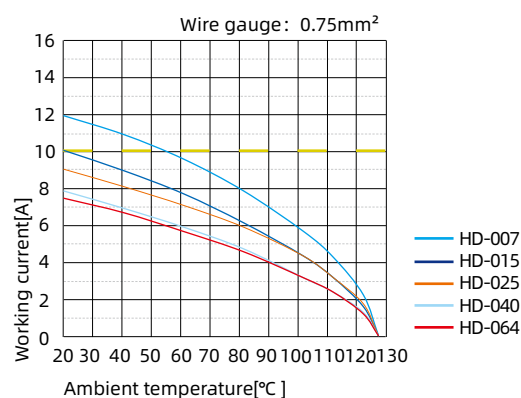

## Stamped contacts:

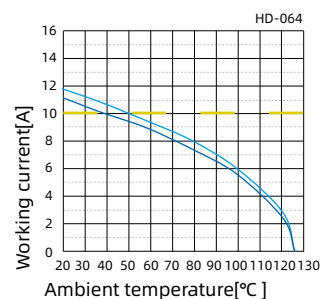
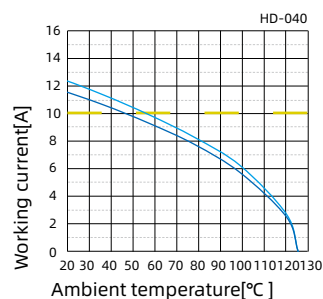

— Wire gauge: 2.5mm<sup>2</sup>  
— Wire gauge: 1.5mm<sup>2</sup>

— Wire gauge: 2.5mm<sup>2</sup>  
— Wire gauge: 1.5mm<sup>2</sup>

## HDD SERIES Ultra-high density inserts

### Technical characteristics

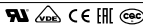
Specifications	DIN EN 60 664 DIN EN 61 984
Approvals	
Inserts	
Number of contacts	24,42,72,108,144(72x2), 216(108x2)+PE
Electrical data acc. to EN 61 984	
-Rated current	10A
-Rated voltage	250V
-Rated impulse voltage	4kV
-Pollution degree	3
-Pollution degree 2 also	10A 230/400V 4kV 2
Rated voltage acc. to UL	600V
Insulation resistance	$\geq 10^{10}\Omega$
Material	polycarbonate
Limiting temperatures	-40°C ...+125°C
Flammability acc. to UL 94	V0
Mechanical working life(mating cycles) $\geq$	500
Contacts	
Material	copper alloy
Surface	hard-gold plated hard-silver plated
Contact resistance	$\leq 3m\Omega$
Crimp terminal	
-Wire gauge	0.14-2.5mm <sup>2</sup>
-AWG	26-14

### Current carrying capacity

The current carrying is limited by maximum temperature of materials for inserts and contacts including terminals

Control and test procedures according to DIN EN 60512-5

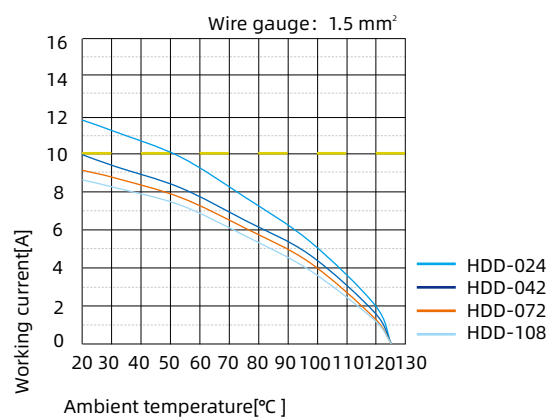
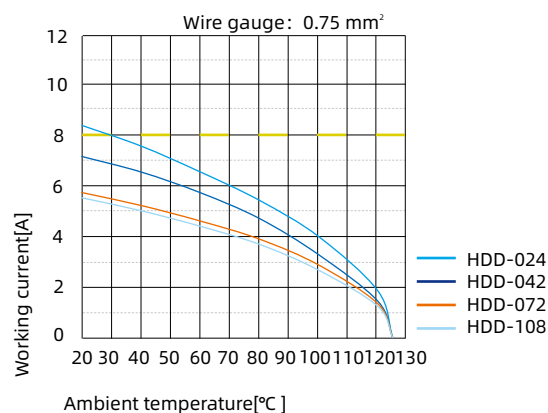

## HD HDD Modified contact arrangement up to 500 V

The connector series HDD and HD equipped with all contacts may be used for voltages up to 250 V, pollution degree 3. A modified contact loading arrangement permits use up to 500 V also in the same pollution degree. According to DIN EN 61 984 connectors should not be coupled or decoupled under electrical load.

### Contact arrangement view from termination side

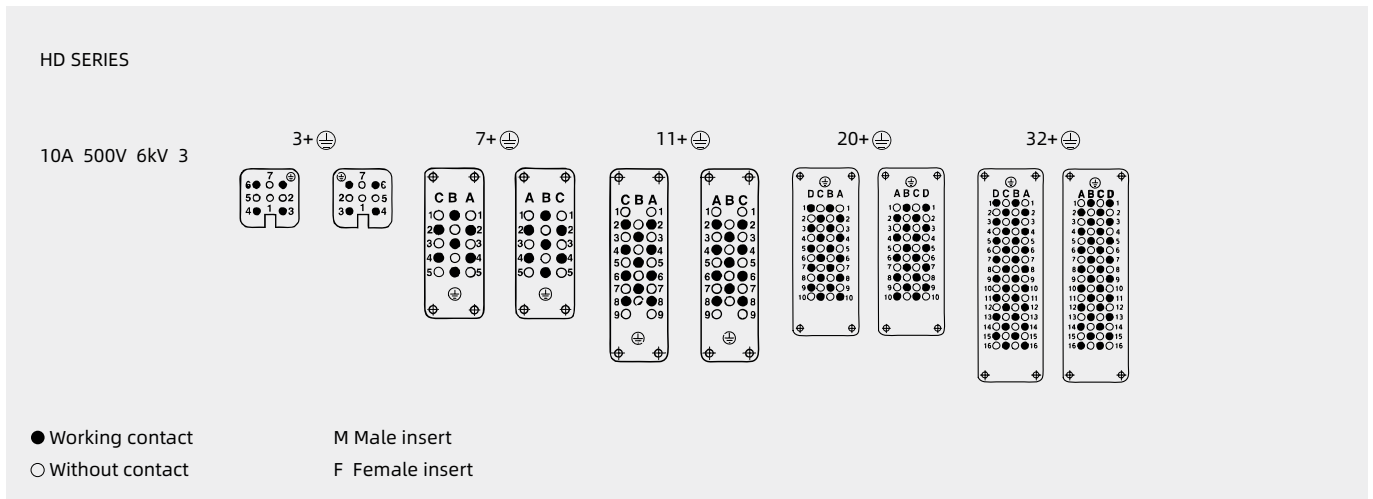

### Contact arrangement view from termination side

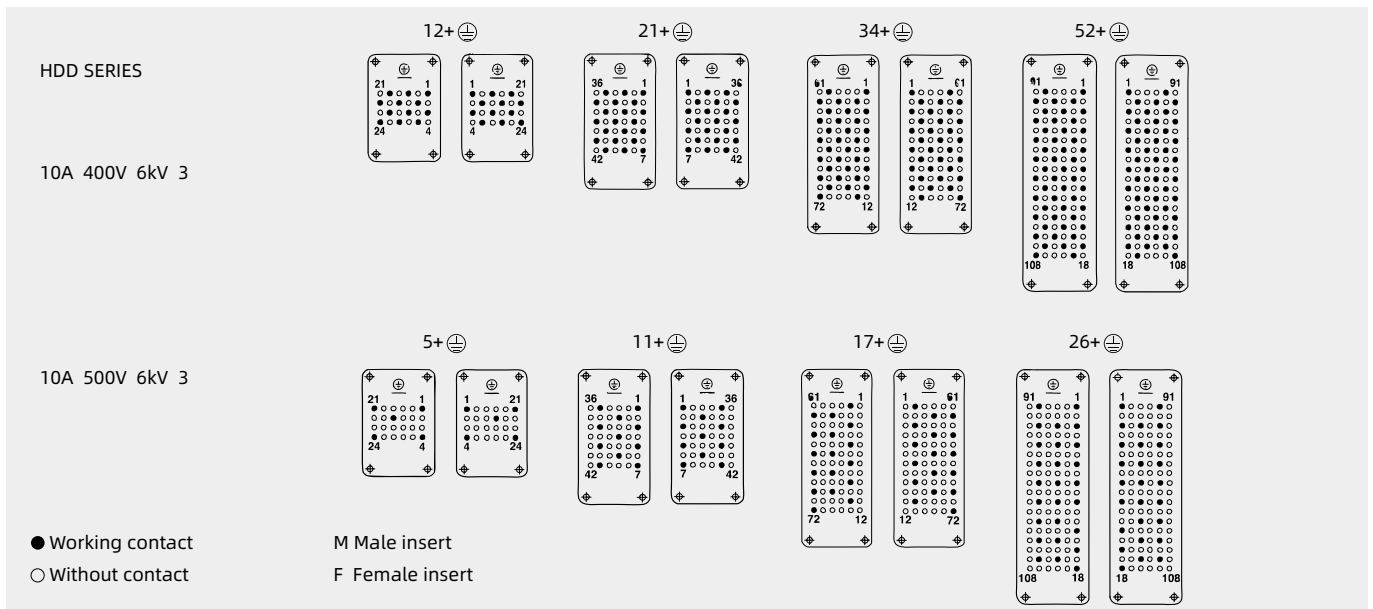

# HD-007 Ultra-high density inserts

250V 10A 7+ 



## Inserts

Hoods/Housings: **size 3A(only for plastic)**, please find the details on page 15-06~15-07.

Crimp terminal

order crimp contacts separately



Insert	Designation	Order No.
Male	HD-007-MC	125 007 010 0001
Female	HD-007-FC	125 007 020 0001

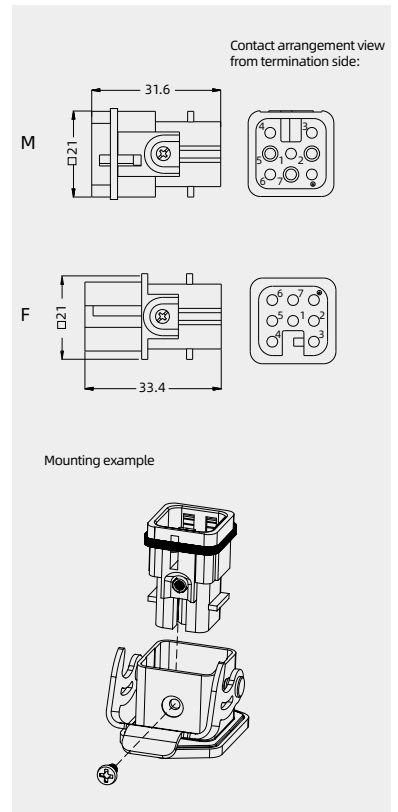

## Crimp contacts

Crimp contacts 10A

Contact resistance  $\leq 3m\Omega$   
silver plated



gold plated



More crimp contacts 10A  
see P13-02,P13-03.

Tools

Crimping tool



Contact removal tool

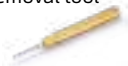

Male	Order No.	Female	Order No.
CDSM-0.25	101 017 110 0101	CDSF-0.25	101 017 120 0101
CDSM-0.37	101 017 110 0301	CDSF-0.37	101 017 120 0301
CDSM-0.50	101 017 110 0401	CDSF-0.50	101 017 120 0401
CDSM-0.75	101 017 110 0601	CDSF-0.75	101 017 120 0601
CDSM-1.0	101 017 110 0801	CDSF-1.0	101 017 120 0801
CDSM-1.5	101 017 110 0901	CDSF-1.5	101 017 120 0901
CDSM-2.5	101 017 110 1001	CDSF-2.5	101 017 120 1001

Male	Order No.	Female	Order No.
CDGM-0.25	101 017 210 0101	CDGF-0.25	101 017 220 0101
CDGM-0.37	101 017 210 0301	CDGF-0.37	101 017 220 0301
CDGM-0.50	101 017 210 0401	CDGF-0.50	101 017 220 0401
CDGM-0.75	101 017 210 0601	CDGF-0.75	101 017 220 0601
CDGM-1.0	101 017 210 0801	CDGF-1.0	101 017 220 0801
CDGM-1.5	101 017 210 0901	CDGF-1.5	101 017 220 0901
CDGM-2.5	101 017 210 1001	CDGF-2.5	101 017 220 1001

Wire gauge	Designation	Order No.
0.14-4mm <sup>2</sup>	TL02G	198 001 001 0011

For the crimping contacts and removing contacts instructions, please find the page 06-23~06-24.

Application	Designation	Order No.
for crimp contacts 10A	TL00	198 001 000 0001

More tools detail please find the page 32-03~32-06.

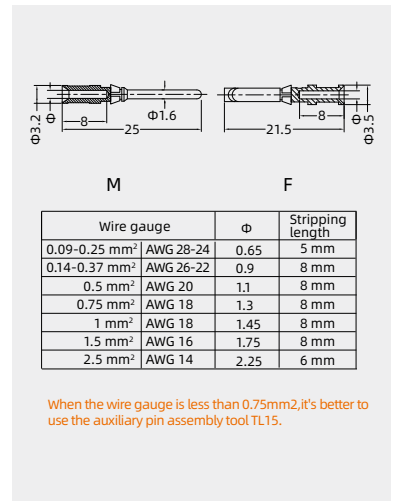

Notes: The tools for crimp terminal may influence the product quality and stability. Please select the tools recognized by our company.

# HD-008 Ultra-high density inserts

-120V/~50V 10A 8



## Inserts

Hoods/Housings: **size 3A**, please find the details on page 15-06~15-16.1.

### Crimp terminal

order crimp contacts separately



Insert	Designation	Order No.
Male	HD-008-MC	125 008 010 0001
Female	HD-008-FC	125 008 020 0001

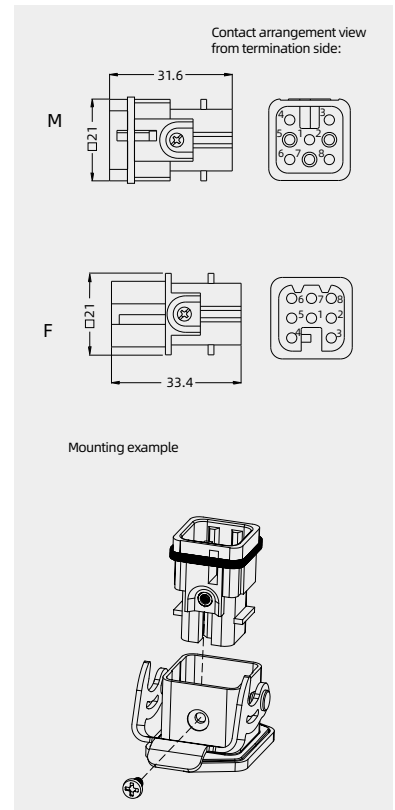

## Crimp contacts

### Crimp contacts 10A

Contact resistance  $\leq 3m\Omega$   
silver plated



gold plated



Male	Order No.	Female	Order No.
CDSM-0.25	101 017 110 0101	CDSF-0.25	101 017 120 0101
CDSM-0.37	101 017 110 0301	CDSF-0.37	101 017 120 0301
CDSM-0.50	101 017 110 0401	CDSF-0.50	101 017 120 0401
CDSM-0.75	101 017 110 0601	CDSF-0.75	101 017 120 0601
CDSM-1.0	101 017 110 0801	CDSF-1.0	101 017 120 0801
CDSM-1.5	101 017 110 0901	CDSF-1.5	101 017 120 0901
CDSM-2.5	101 017 110 1001	CDSF-2.5	101 017 120 1001

More crimp contacts 10A  
see P13-02,P13-03.

### Tools

Crimping tool



Contact removal tool

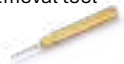

Male	Order No.	Female	Order No.
CDGM-0.25	101 017 210 0101	CDGF-0.25	101 017 220 0101
CDGM-0.37	101 017 210 0301	CDGF-0.37	101 017 220 0301
CDGM-0.50	101 017 210 0401	CDGF-0.50	101 017 220 0401
CDGM-0.75	101 017 210 0601	CDGF-0.75	101 017 220 0601
CDGM-1.0	101 017 210 0801	CDGF-1.0	101 017 220 0801
CDGM-1.5	101 017 210 0901	CDGF-1.5	101 017 220 0901
CDGM-2.5	101 017 210 1001	CDGF-2.5	101 017 220 1001

Wire gauge	Designation	Order No.
0.14-4mm <sup>2</sup>	TL02G	198 001 001 0011

For the crimping contacts and removing contacts instructions, please find the page 06-23~06-24.

Application	Designation	Order No.
for crimp contacts 10A	TL00	198 001 000 0001

More tools detail please find the page 32-03~32-06.

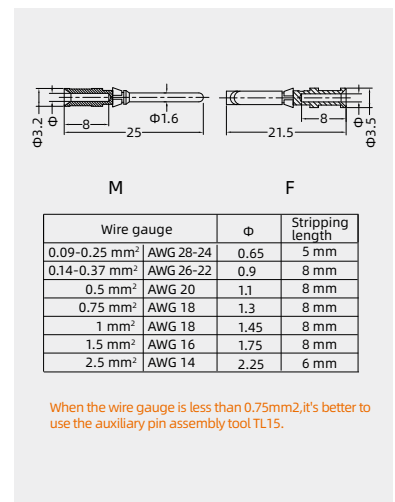

When the wire gauge is less than 0.75mm<sup>2</sup>, it's better to use the auxiliary pin assembly tool TL15.

Notes: The tools for crimp terminal may influence the product quality and stability. Please select the tools recognized by our company.

## HD-008 Quick-in



### Technical specification

Specifications	DIN EN 60 664 DIN EN 61 984
Approvals	
Inserts	
Number of contacts	8
Electrical data acc. to EN 61 984	
-Rated current	10A
-Rated voltage	50/~120V
-Rated impulse voltage	0.8kV
-Pollution degree	3
Insulation resistance	$\geq 10^{10}\Omega$
Material	polycarbonate
Colour	RAL 7032(light grey)
Limiting temperatures	-40°C ...+125°C
Flammability acc. to UL 94	V0
Mechanical working life(mating cycles) $\geq 500$	
Contacts	
Terminal	spring terminal(Quick-in)
Material	copper alloy
Surface	silver plated
Contact resistance	$\leq 3m\Omega$
Crimp terminal	
-Wire gauge	0.5-2.5mm <sup>2</sup>
-AWG	20-14
(For wires with crimped ferrule)	
-Wire gauge	0.14-1.5mm <sup>2</sup>
-AWG	26-16
Stripping length	10±0.5mm



HD-008 Qulck-in

-120V /~50V 10A 8

## Inserts

Hoods/Housings: size 3A, please find the details on page 15-06~15-16.1.

### Spring Terminal(Quick-in)



Insert	Designation	Order No.
Male	HD-008-MQ	125 008 001 0001
Female	HD-008-FQ	125 008 002 0001

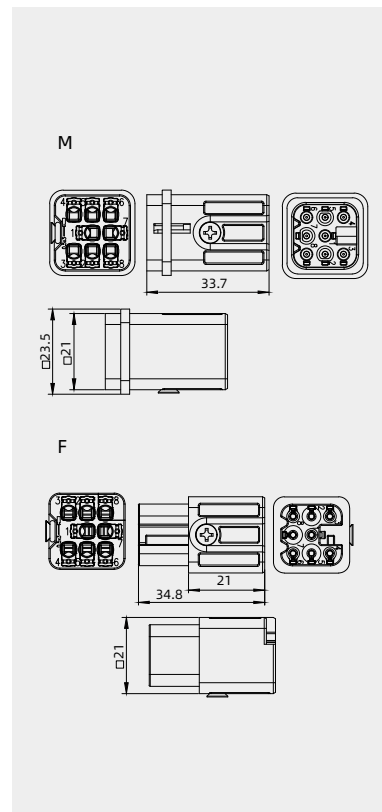

# HD-015 Ultra-high density inserts

250V 10A 15+



## Inserts

Hoods/Housings: size 10A, detail please find the page 15-17~15-18.1.

Crimp terminal  
order crimp contacts separately



Insert	Designation	Order No.
Male	HD-015-MC	125 015 010 0001
Female	HD-015-FC	125 015 020 0001

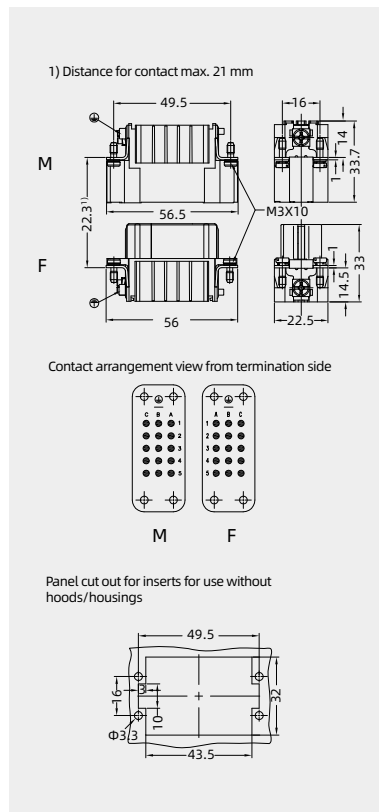

## Crimp contacts

Crimp contacts 10A

Contact resistance  $\leq 3m\Omega$   
silver plated



gold plated



More crimp contacts 10A  
see P13-02,P13-03.

### Tools

Crimping tool



Contact removal tool

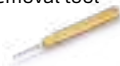

Male	Order No.	Female	Order No.
CDSM-0.25	101 017 110 0101	CDSF-0.25	101 017 120 0101
CDSM-0.37	101 017 110 0301	CDSF-0.37	101 017 120 0301
CDSM-0.50	101 017 110 0401	CDSF-0.50	101 017 120 0401
CDSM-0.75	101 017 110 0601	CDSF-0.75	101 017 120 0601
CDSM-1.0	101 017 110 0801	CDSF-1.0	101 017 120 0801
CDSM-1.5	101 017 110 0901	CDSF-1.5	101 017 120 0901
CDSM-2.5	101 017 110 1001	CDSF-2.5	101 017 120 1001

Male	Order No.	Female	Order No.
CDGM-0.25	101 017 210 0101	CDGF-0.25	101 017 220 0101
CDGM-0.37	101 017 210 0301	CDGF-0.37	101 017 220 0301
CDGM-0.50	101 017 210 0401	CDGF-0.50	101 017 220 0401
CDGM-0.75	101 017 210 0601	CDGF-0.75	101 017 220 0601
CDGM-1.0	101 017 210 0801	CDGF-1.0	101 017 220 0801
CDGM-1.5	101 017 210 0901	CDGF-1.5	101 017 220 0901
CDGM-2.5	101 017 210 1001	CDGF-2.5	101 017 220 1001

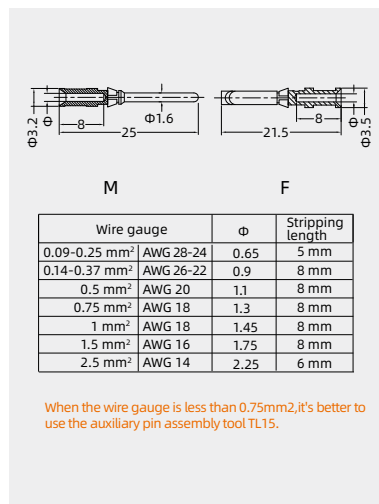

Wire gauge	Designation	Order No.
0.14-4mm <sup>2</sup>	TL02G	198 001 001 0011

For the crimping contacts and removing contacts instructions, please find the page 06-23~06-24.

Application	Designation	Order No.
for crimp contacts 10A	TL00	198 001 000 0001

More tools detail please find the page 32-03~32-06.

Notes: The tools for crimp terminal may influence the product quality and stability. Please select the tools recognized by our company.

# HD-025 Ultra-high density inserts

250V 10A 25+ 



## Inserts

Hoods/Housings: size 16A,detail please find the page15-19~15-20.

Crimp terminal  
order crimp contacts separately



Insert	Designation	Order No.
Male	HD-025-MC	125 025 010 0001
Female	HD-025-FC	125 025 020 0001

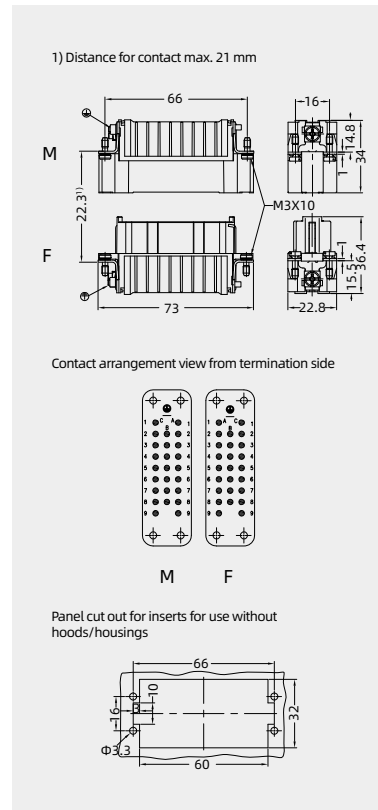

## Crimp contacts

Crimp contacts 10A

Contact resistance  $\leq 3m\Omega$   
silver plated



gold plated



More crimp contacts 10A  
see P13-02,P13-03.

Tools

Crimping tool



Contact removal tool

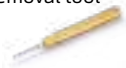

Male	Order No.	Female	Order No.
CDSM-0.25	101 017 110 0101	CDSF-0.25	101 017 120 0101
CDSM-0.37	101 017 110 0301	CDSF-0.37	101 017 120 0301
CDSM-0.50	101 017 110 0401	CDSF-0.50	101 017 120 0401
CDSM-0.75	101 017 110 0601	CDSF-0.75	101 017 120 0601
CDSM-1.0	101 017 110 0801	CDSF-1.0	101 017 120 0801
CDSM-1.5	101 017 110 0901	CDSF-1.5	101 017 120 0901
CDSM-2.5	101 017 110 1001	CDSF-2.5	101 017 120 1001

Male	Order No.	Female	Order No.
CDGM-0.25	101 017 210 0101	CDGF-0.25	101 017 220 0101
CDGM-0.37	101 017 210 0301	CDGF-0.37	101 017 220 0301
CDGM-0.50	101 017 210 0401	CDGF-0.50	101 017 220 0401
CDGM-0.75	101 017 210 0601	CDGF-0.75	101 017 220 0601
CDGM-1.0	101 017 210 0801	CDGF-1.0	101 017 220 0801
CDGM-1.5	101 017 210 0901	CDGF-1.5	101 017 220 0901
CDGM-2.5	101 017 210 1001	CDGF-2.5	101 017 220 1001

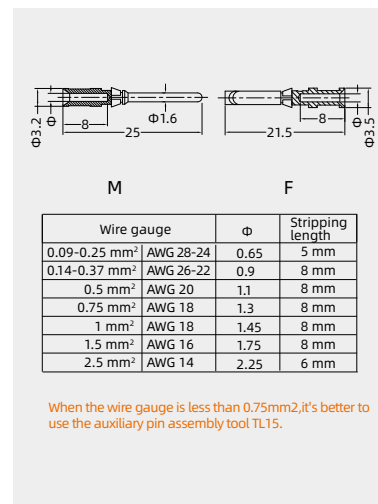

Wire gauge	Designation	Order No.
0.14-4mm <sup>2</sup>	TL02G	198 001 001 0011

For the crimping contacts and removing contacts instructions, please find the page 06-23~06-24.

Application	Designation	Order No.
for crimp contacts 10A	TL00	198 001 000 0001

More tools detail please find the page32-03~32-06.

Notes: The tools for crimp terminal may influence the product quality and stability.  
Please select the tools recognized by our company.

## HD-050 Ultra-high density inserts

250V 10A 50+



### Inserts

Hoods/Housings: size 32A, please find the details on page 15-21~15-24.

Crimp terminal  
order crimp contacts separately



Insert	Designation	Order No.
Male	HD-025-MC	125 025 010 0001
	HD-025-MC(Z) <sup>1)</sup>	125 025 010 0002
Female	HD-025-FC	125 025 020 0001
	HD-025-FC(Z) <sup>1)</sup>	125 025 020 0002

<sup>1)</sup> Z represents large size digital plug.

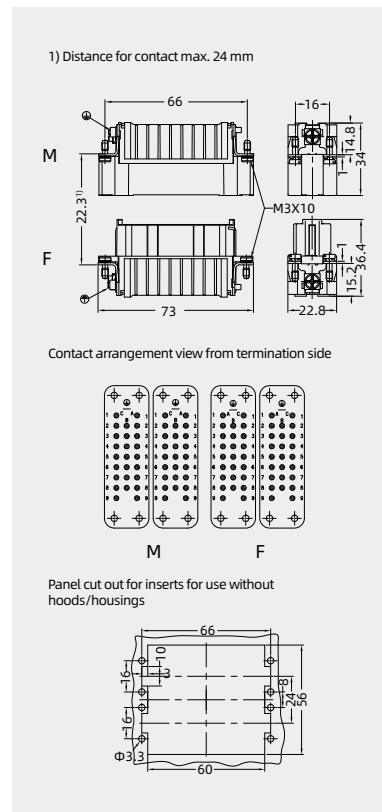

## Crimp contacts

Crimp contacts 10A

Contact resistance  $\leq 3m\Omega$   
silver plated



gold plated



More crimp contacts 10A  
see P13-02,P13-03.

Tools

Crimping tool



Contact removal tool



Male	Order No.	Female	Order No.
CDSM-0.25	101 017 110 0101	CDSF-0.25	101 017 120 0101
CDSM-0.37	101 017 110 0301	CDSF-0.37	101 017 120 0301
CDSM-0.50	101 017 110 0401	CDSF-0.50	101 017 120 0401
CDSM-0.75	101 017 110 0601	CDSF-0.75	101 017 120 0601
CDSM-1.0	101 017 110 0801	CDSF-1.0	101 017 120 0801
CDSM-1.5	101 017 110 0901	CDSF-1.5	101 017 120 0901
CDSM-2.5	101 017 110 1001	CDSF-2.5	101 017 120 1001
CDGM-0.25	101 017 210 0101	CDGF-0.25	101 017 220 0101
CDGM-0.37	101 017 210 0301	CDGF-0.37	101 017 220 0301
CDGM-0.50	101 017 210 0401	CDGF-0.50	101 017 220 0401
CDGM-0.75	101 017 210 0601	CDGF-0.75	101 017 220 0601
CDGM-1.0	101 017 210 0801	CDGF-1.0	101 017 220 0801
CDGM-1.5	101 017 210 0901	CDGF-1.5	101 017 220 0901
CDGM-2.5	101 017 210 1001	CDGF-2.5	101 017 220 1001

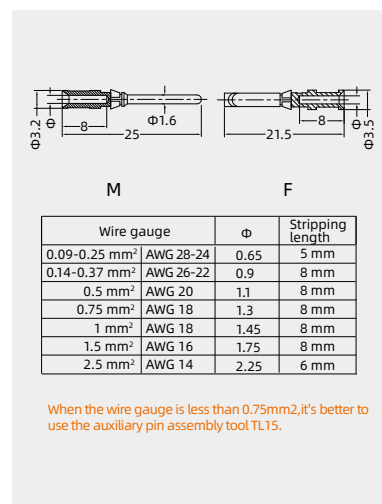

Wire gauge	Designation	Order No.
0.14-4mm <sup>2</sup>	TL02G	198 001 001 0011

For the crimping contacts and removing contacts instructions, please find the page 06-23-06-24.

Application	Designation	Order No.
for crimp contacts 10A	TL00	198 001 000 0001

More tools detail please find the page 32-03~32-06.

Notes: The tools for crimp terminal may influence the product quality and stability.  
Please select the tools recognized by our company.

# HD-040 Ultra-high density inserts

250V 10A 40+ 

FR

## Inserts

Hoods/Housings: size 16B, please find the details on page 15-70~15-1071.

### Crimp terminal

order crimp contacts separately



Insert	Designation	Order No.
Male	HD-040-MC	125 040 010 0001
Female	HD-040-FC	125 040 020 0001

### Wrap terminal<sup>1)</sup> 1x1 mm



Insert	Designation	Order No.
Male	HD-040-MTHT	125 040 014 0001
Female	HD-040-FTHT	125 040 024 0001

1) See P00-14 for the structural characteristics of wrap terminal.

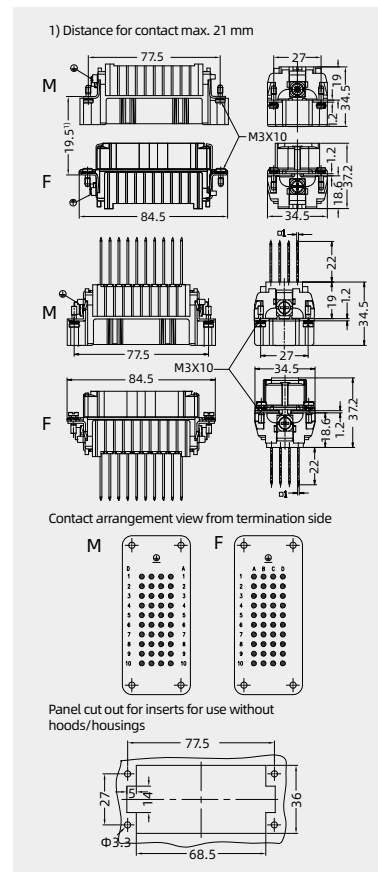

## Crimp contacts

### Crimp contacts 10A

Contact resistance  $\leq 3m\Omega$   
silver plated



Male	Order No.	Female	Order No.
CDSM-0.25	101 017 110 0101	CDSF-0.25	101 017 120 0101
CDSM-0.37	101 017 110 0301	CDSF-0.37	101 017 120 0301
CDSM-0.50	101 017 110 0401	CDSF-0.50	101 017 120 0401
CDSM-0.75	101 017 110 0601	CDSF-0.75	101 017 120 0601
CDSM-1.0	101 017 110 0801	CDSF-1.0	101 017 120 0801
CDSM-1.5	101 017 110 0901	CDSF-1.5	101 017 120 0901
CDSM-2.5	101 017 110 1001	CDSF-2.5	101 017 120 1001

gold plated



Male	Order No.	Female	Order No.
CDGM-0.25	101 017 210 0101	CDGF-0.25	101 017 220 0101
CDGM-0.37	101 017 210 0301	CDGF-0.37	101 017 220 0301
CDGM-0.50	101 017 210 0401	CDGF-0.50	101 017 220 0401
CDGM-0.75	101 017 210 0601	CDGF-0.75	101 017 220 0601
CDGM-1.0	101 017 210 0801	CDGF-1.0	101 017 220 0801
CDGM-1.5	101 017 210 0901	CDGF-1.5	101 017 220 0901
CDGM-2.5	101 017 210 1001	CDGF-2.5	101 017 220 1001

More crimp contacts 10A  
see P13-02,P13-03.

### Tools

Crimping tool



Contact removal tool

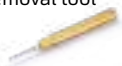

Wire gauge	Designation	Order No.
0.14-4mm <sup>2</sup>	TL02G	198 001 001 0011
For the crimping contacts and removing contacts instructions, please find the page 06-23-06-24.		
Application	Designation	Order No.
for crimp contacts 10A	TL00	198 001 000 0001

More tools detail please find the page 32-03~32-06.

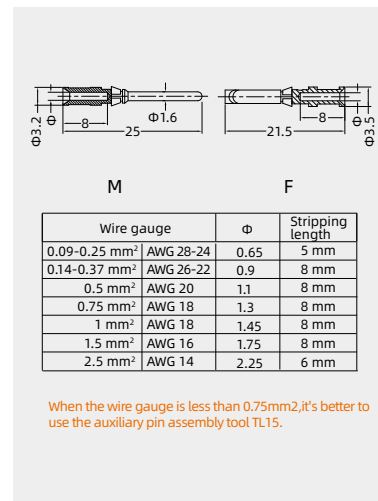

Notes: The tools for crimp terminal may influence the product quality and stability.  
Please select the tools recognized by our company.

# HD-040 Ultra-high density inserts

250V 10A 40+ 

CE  ENEC

## Inserts

Hoods/Housings: size 16B, please find the details on page 15-70~15-1071.

### Crimp terminal

order crimp contacts separately



The insert only matches 10A stamped contacts.

Insert	Designation	Order No.
Male	HD-040-MC/P	125 040 010 0021
	HD-040-FC/P	125 040 020 0021

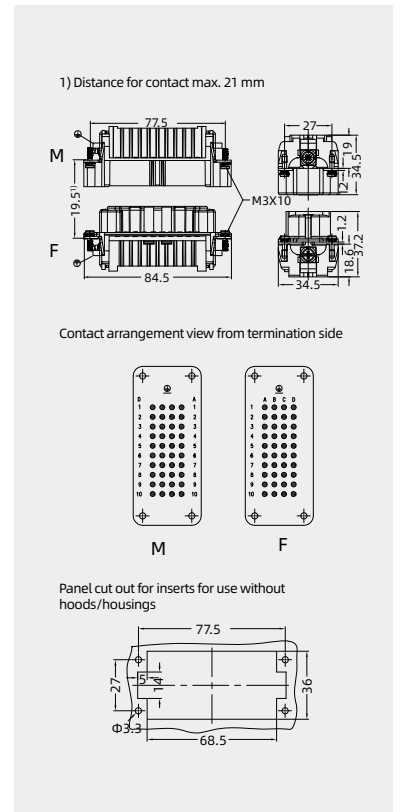

## Crimp contacts

### Stamped contacts 10A

silver plated



coil stock



Wire gauge	contacts	Designation	Order No.
0.5-1.5mm <sup>2</sup>	male	CDSM-1.5P	101 017 110 0905
	female	CDSF-1.5P	101 017 120 0905
1.5-2.5mm <sup>2</sup>	male	CDSM-2.5P	101 017 110 1005
	female	CDSF-2.5P	101 017 120 1005

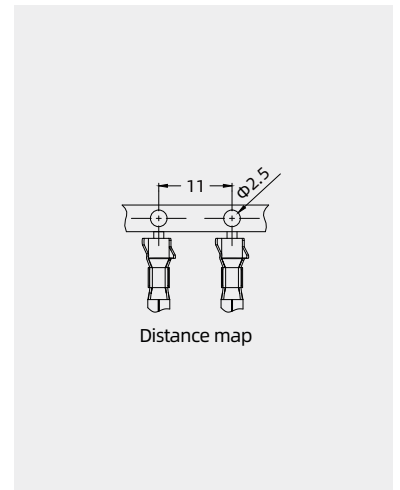

### Tools

#### Crimping tool



#### Contact removal tool



Wire gauge	Designation	Order No.
0.5-2.5mm <sup>2</sup>	TL14	198 001 001 0022

Application	Designation	Order No.
10A male contacts	TL00	198 001 000 0001
10A female contacts	TL13	198 001 000 0025

更多工具详情请参见第 32-03~32-06 页

Notes: The tools for crimp terminal may influence the product quality and stability. Please select the tools recognized by our company.

# HD-064 Ultra-high density inserts

250V 10A 64+ 

EAC

## Inserts

Hoods/Housings: size 24B, please find the details on page 15-108~15-150.

### Crimp terminal

order crimp contacts separately



Insert	Designation	Order No.
Male	HD-064-MC	125 064 010 0001
Female	HD-064-FC	125 064 020 0001

### Wrap terminal<sup>1)</sup> 1x1 mm



Insert	Designation	Order No.
Male	HD-064-MTHT	125 064 014 0001
Female	HD-064-FTHT	125 064 024 0001

1) See P00-14 for the structural characteristics of wrap terminal.

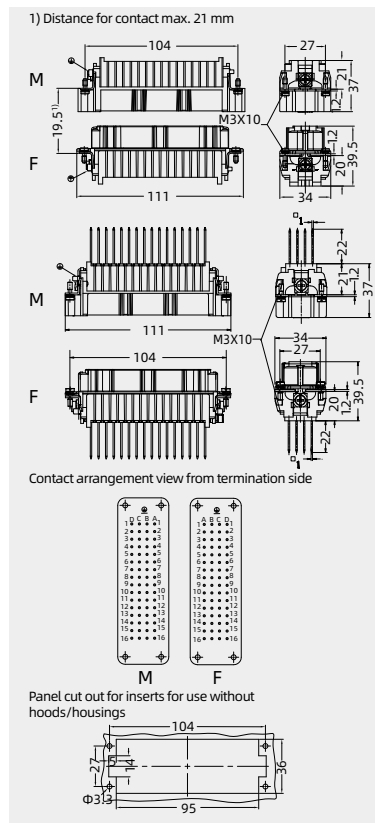

## Crimp contacts

### Crimp contacts 10A

Contact resistance  $\leq 3m\Omega$   
silver plated



Male	Order No.	Female	Order No.
CDSM-0.25	101 017 110 0101	CDSF-0.25	101 017 120 0101
CDSM-0.37	101 017 110 0301	CDSF-0.37	101 017 120 0301
CDSM-0.50	101 017 110 0401	CDSF-0.50	101 017 120 0401
CDSM-0.75	101 017 110 0601	CDSF-0.75	101 017 120 0601
CDSM-1.0	101 017 110 0801	CDSF-1.0	101 017 120 0801
CDSM-1.5	101 017 110 0901	CDSF-1.5	101 017 120 0901
CDSM-2.5	101 017 110 1001	CDSF-2.5	101 017 120 1001

gold plated



Male	Order No.	Female	Order No.
CDGM-0.25	101 017 210 0101	CDGF-0.25	101 017 220 0101
CDGM-0.37	101 017 210 0301	CDGF-0.37	101 017 220 0301
CDGM-0.50	101 017 210 0401	CDGF-0.50	101 017 220 0401
CDGM-0.75	101 017 210 0601	CDGF-0.75	101 017 220 0601
CDGM-1.0	101 017 210 0801	CDGF-1.0	101 017 220 0801
CDGM-1.5	101 017 210 0901	CDGF-1.5	101 017 220 0901
CDGM-2.5	101 017 210 1001	CDGF-2.5	101 017 220 1001

More crimp contacts 10A  
see P13-02,P13-03.

### Tools

Crimping tool



Wire gauge	Designation	Order No.
0.14-4mm <sup>2</sup>	TL02G	198 001 001 0011

For the crimping contacts and removing contacts instructions, please find the page 06-23~06-24.

Contact removal tool



Application	Designation	Order No.
for crimp contacts 10A	TL00	198 001 000 0001

More tools detail please find the page 32-03~32-06.

Notes: The tools for crimp terminal may influence the product quality and stability.  
Please select the tools recognized by our company.

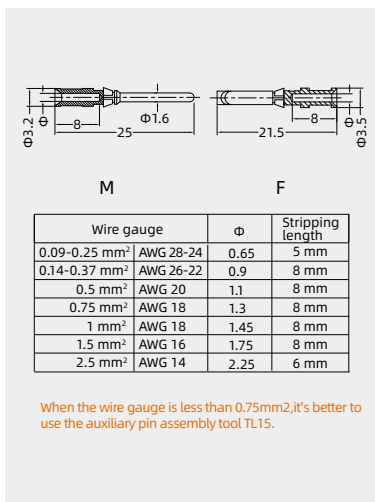

# HD-064 Ultra-high density inserts

250V 10A 64+ 

## Inserts

Hoods/Housings: size 24B, please find the details on page 15-108~15-150.

### Crimp terminal

order crimp contacts separately



The insert only matches 10A stamped contacts.

Insert	Designation	Order No.
Male	HD-064-MC/P	125 064 010 0021
	HD-064-FC/P	125 064 020 0021

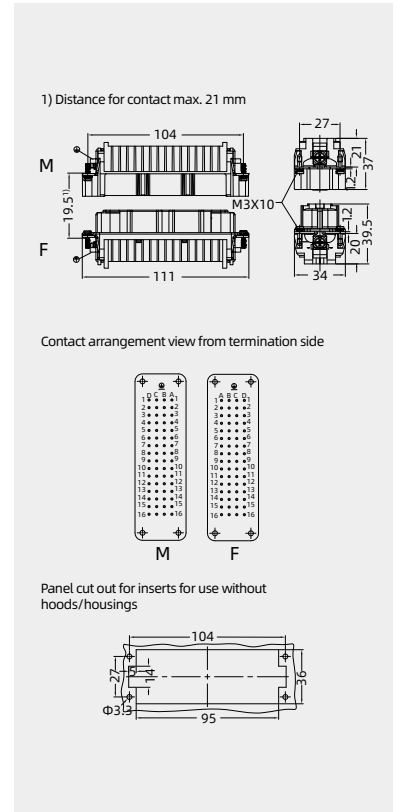

## Crimp contacts

### Stamped contacts 10A

silver plated



coil stock



Wire gauge	contacts	Designation	Order No.
0.5-1.5mm <sup>2</sup>	male	CDSM-1.5P	101 017 110 0905
	female	CDSF-1.5P	101 017 120 0905
1.5-2.5mm <sup>2</sup>	male	CDSM-2.5P	101 017 110 1005
	female	CDSF-2.5P	101 017 120 1005

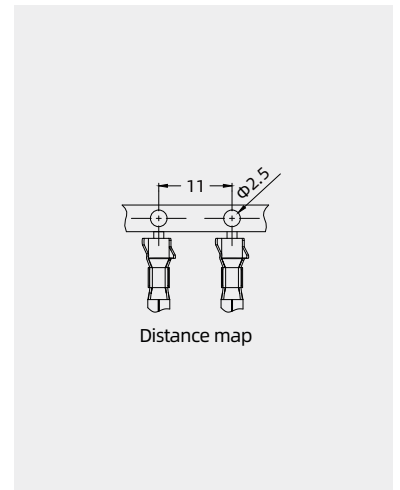

### Tools

#### Crimping tool



#### Contact removal tool



Wire gauge	Designation	Order No.
0.5-2.5mm <sup>2</sup>	TL14	198 001 001 0022

Application	Designation	Order No.
10A male contacts	TL00	198 001 000 0001
10A female contacts	TL13	198 001 000 0025

\*Please find the details of crimp contact tools on page 32-03~32-06.

Notes: The tools for crimp terminal may influence the product quality and stability. Please select the tools recognized by our company.



# HD-080 Ultra-high density inserts

250V 10A 80+



## Inserts

Hoods/Housings: size 32B, please find the details on page 15-151~15-159.

Crimp terminal  
order crimp contacts separately



Insert	Designation	Order No.
Male	HD-040-MC	125 040 010 0001
	HD-040-MC(Z) <sup>1)</sup>	125 040 010 0002
Female	HD-040-FC	125 040 020 0001
	HD-040-FC(Z) <sup>1)</sup>	125 040 020 0002

1) Z represents large size digital plug.

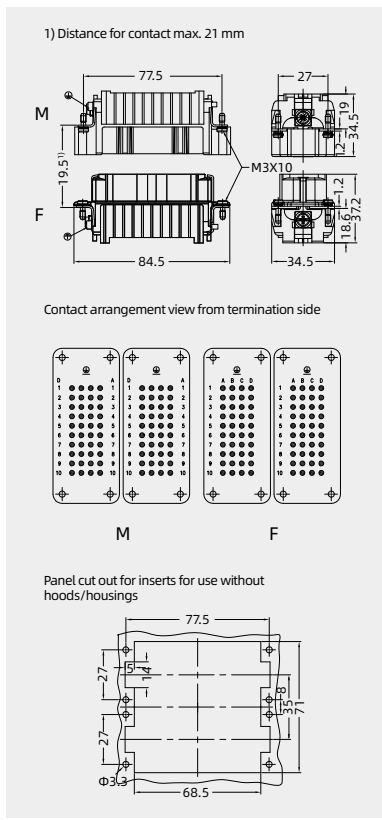

## Crimp contacts

Crimp contacts 10A

Contact resistance ≤ 3mΩ  
silver plated



gold plated

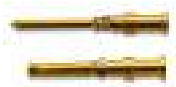

More crimp contacts 10A  
see P13-02,P13-03.

Male	Order No.	Female	Order No.
CDSM-0.25	101 017 110 0101	CDSF-0.25	101 017 120 0101
CDSM-0.37	101 017 110 0301	CDSF-0.37	101 017 120 0301
CDSM-0.50	101 017 110 0401	CDSF-0.50	101 017 120 0401
CDSM-0.75	101 017 110 0601	CDSF-0.75	101 017 120 0601
CDSM-1.0	101 017 110 0801	CDSF-1.0	101 017 120 0801
CDSM-1.5	101 017 110 0901	CDSF-1.5	101 017 120 0901
CDSM-2.5	101 017 110 1001	CDSF-2.5	101 017 120 1001
CDGM-0.25	101 017 210 0101	CDGF-0.25	101 017 220 0101
CDGM-0.37	101 017 210 0301	CDGF-0.37	101 017 220 0301
CDGM-0.50	101 017 210 0401	CDGF-0.50	101 017 220 0401
CDGM-0.75	101 017 210 0601	CDGF-0.75	101 017 220 0601
CDGM-1.0	101 017 210 0801	CDGF-1.0	101 017 220 0801
CDGM-1.5	101 017 210 0901	CDGF-1.5	101 017 220 0901
CDGM-2.5	101 017 210 1001	CDGF-2.5	101 017 220 1001

## Tools

Crimping tool



Contact removal tool

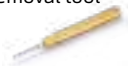

Wire gauge	Designation	Order No.
0.14-4mm <sup>2</sup>	TL02G	198 001 001 0011
For the crimping contacts and removing contacts instructions, please find the page 06-23-06-24.		
Application	Designation	Order No.
for crimp contacts 10A	TL00	198 001 000 0001
More tools detail please find the page 32-03~32-06.		

Notes: The tools for crimp terminal may influence the product quality and stability.  
Please select the tools recognized by our company.

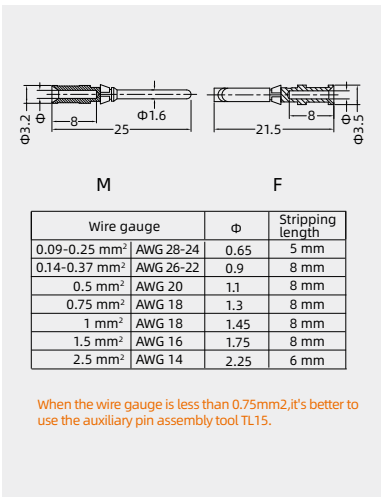

## HD-128 Ultra-high density inserts

250V 10A 128+



### Inserts

Hoods/Housings: size 48B, please find the details on page 15-160~15-162.

Crimp terminal  
order crimp contacts separately



Insert	Designation	Order No.
Male	HD-064-MC	125 064 010 0001
	HD-064-MC(Z) <sup>1)</sup>	125 064 010 0002
Female	HD-064-FC	125 064 020 0001
	HD-064-FC(Z) <sup>1)</sup>	125 064 020 0002

<sup>1)</sup> Z represents large size digital plug.

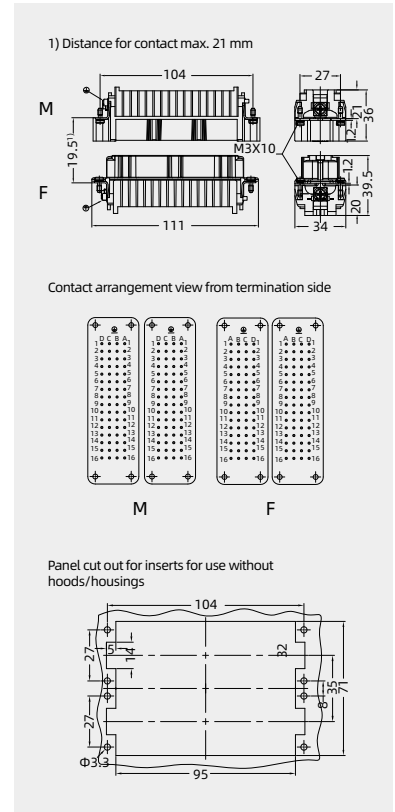

## Crimp contacts

Crimp contacts 10A

Contact resistance  $\leq 3m\Omega$   
silver plated



gold plated



More crimp contacts 10A  
see P13-02,P13-03.

Tools

Crimping tool



Contact removal tool

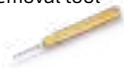

Male	Order No.	Female	Order No.
CDSM-0.25	101 017 110 0101	CDSF-0.25	101 017 120 0101
CDSM-0.37	101 017 110 0301	CDSF-0.37	101 017 120 0301
CDSM-0.50	101 017 110 0401	CDSF-0.50	101 017 120 0401
CDSM-0.75	101 017 110 0601	CDSF-0.75	101 017 120 0601
CDSM-1.0	101 017 110 0801	CDSF-1.0	101 017 120 0801
CDSM-1.5	101 017 110 0901	CDSF-1.5	101 017 120 0901
CDSM-2.5	101 017 110 1001	CDSF-2.5	101 017 120 1001

Male	Order No.	Female	Order No.
CDGM-0.25	101 017 210 0101	CDGF-0.25	101 017 220 0101
CDGM-0.37	101 017 210 0301	CDGF-0.37	101 017 220 0301
CDGM-0.50	101 017 210 0401	CDGF-0.50	101 017 220 0401
CDGM-0.75	101 017 210 0601	CDGF-0.75	101 017 220 0601
CDGM-1.0	101 017 210 0801	CDGF-1.0	101 017 220 0801
CDGM-1.5	101 017 210 0901	CDGF-1.5	101 017 220 0901
CDGM-2.5	101 017 210 1001	CDGF-2.5	101 017 220 1001

Wire gauge	Designation	Order No.
0.14-4mm <sup>2</sup>	TL02G	198 001 001 0011

For the crimping contacts and removing contacts instructions, please find the page 06-23~06-24.

Application	Designation	Order No.
for crimp contacts 10A	TL00	198 001 000 0001

More tools detail please find the page 32-03~32-06.

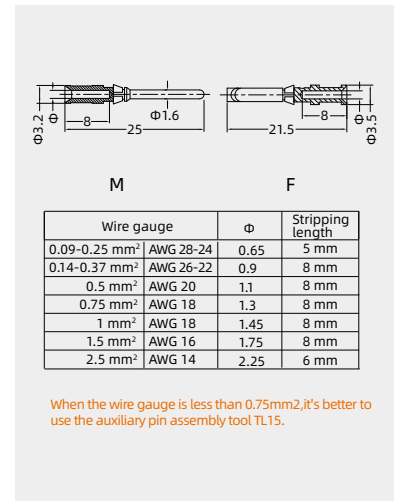

Notes: The tools for crimp terminal may influence the product quality and stability. Please select the tools recognized by our company.

# HDD-024 Ultra-high density inserts

250V 10A 24+



## Inserts

Hoods/Housings: size 6B, please find the details on page 15-25~15-38.

Crimp terminal  
order crimp contacts separately



Insert	Designation	Order No.
Male	HDD-024-MC <sup>1)</sup>	126 024 010 0001
Female	HDD-024-FC <sup>1)</sup>	126 024 020 0001

1). Can match PCB adapter, see page 14-02~14-03.

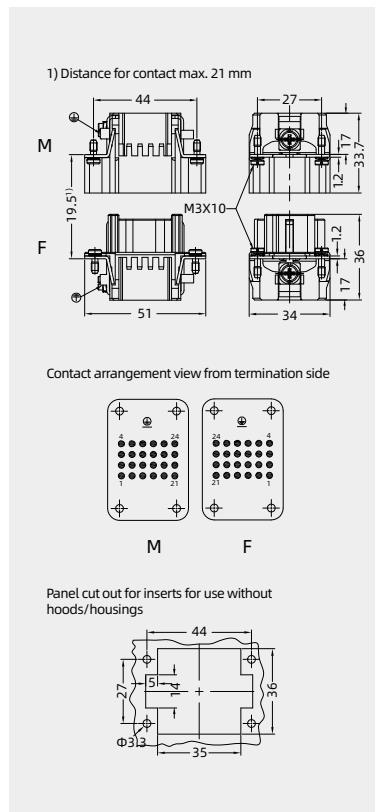

## Crimp contacts

Crimp contacts 10A

Contact resistance  $\leq 3m\Omega$   
silver plated



gold plated



More crimp contacts 10A  
see P13-02, P13-03.

Male	Order No.	Female	Order No.
CDSM-0.25	101 017 110 0101	CDSF-0.25	101 017 120 0101
CDSM-0.37	101 017 110 0301	CDSF-0.37	101 017 120 0301
CDSM-0.50	101 017 110 0401	CDSF-0.50	101 017 120 0401
CDSM-0.75	101 017 110 0601	CDSF-0.75	101 017 120 0601
CDSM-1.0	101 017 110 0801	CDSF-1.0	101 017 120 0801
CDSM-1.5	101 017 110 0901	CDSF-1.5	101 017 120 0901
CDSM-2.5	101 017 110 1001	CDSF-2.5	101 017 120 1001
CDGM-0.25	101 017 210 0101	CDGF-0.25	101 017 220 0101
CDGM-0.37	101 017 210 0301	CDGF-0.37	101 017 220 0301
CDGM-0.50	101 017 210 0401	CDGF-0.50	101 017 220 0401
CDGM-0.75	101 017 210 0601	CDGF-0.75	101 017 220 0601
CDGM-1.0	101 017 210 0801	CDGF-1.0	101 017 220 0801
CDGM-1.5	101 017 210 0901	CDGF-1.5	101 017 220 0901
CDGM-2.5	101 017 210 1001	CDGF-2.5	101 017 220 1001

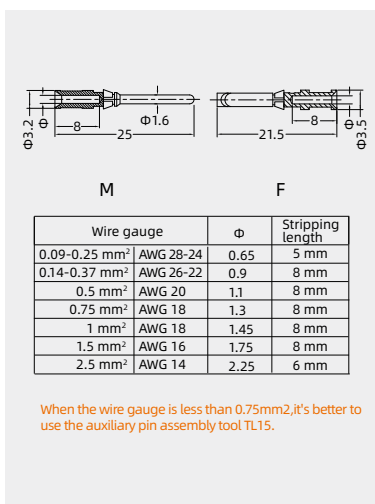

### Tools

Crimping tool



Contact removal tool



Wire gauge	Designation	Order No.
0.14-4mm <sup>2</sup>	TL02G	198 001 001 0011
For the crimping contacts and removing contacts instructions, please find the page 06-23~06-24.		
Application	Designation	Order No.
for crimp contacts 10A	TL00	198 001 000 0001

More tools detail please find the page 32-03~32-06.

Notes: The tools for crimp terminal may influence the product quality and stability.  
Please select the tools recognized by our company.

# HDD-042 Ultra-high density inserts

250V 10A 42+ 



## Inserts

Hoods/Housings: size **10B**, please find the details on page 15-39~15-69.

### Crimp terminal

order crimp contacts separately



Insert	Designation	Order No.
Male	HDD-042-MC <sup>1)</sup>	126 042 010 0001
Female	HDD-042-FC <sup>1)</sup>	126 042 020 0001

<sup>1)</sup>Can match PCB adapter,see page 14-02~14-03.

1) Distance for contact max. 21 mm

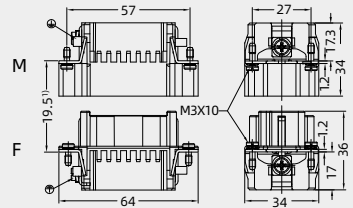

Contact arrangement view from termination side

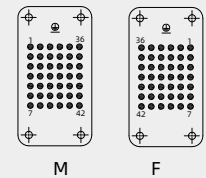

Panel cut out for inserts for use without hoods/housings

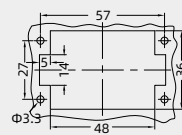

## Crimp contacts

### Crimp contacts 10A

Contact resistance  $\leq 3m\Omega$   
silver plated



gold plated



More crimp contacts 10A  
see P13-02,P13-03.

### Tools

Crimping tool



Contact removal tool

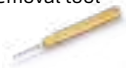

Male	Order No.	Female	Order No.
CDSM-0.25	101 017 110 0101	CDSF-0.25	101 017 120 0101
CDSM-0.37	101 017 110 0301	CDSF-0.37	101 017 120 0301
CDSM-0.50	101 017 110 0401	CDSF-0.50	101 017 120 0401
CDSM-0.75	101 017 110 0601	CDSF-0.75	101 017 120 0601
CDSM-1.0	101 017 110 0801	CDSF-1.0	101 017 120 0801
CDSM-1.5	101 017 110 0901	CDSF-1.5	101 017 120 0901
CDSM-2.5	101 017 110 1001	CDSF-2.5	101 017 120 1001

Male	Order No.	Female	Order No.
CDGM-0.25	101 017 210 0101	CDGF-0.25	101 017 220 0101
CDGM-0.37	101 017 210 0301	CDGF-0.37	101 017 220 0301
CDGM-0.50	101 017 210 0401	CDGF-0.50	101 017 220 0401
CDGM-0.75	101 017 210 0601	CDGF-0.75	101 017 220 0601
CDGM-1.0	101 017 210 0801	CDGF-1.0	101 017 220 0801
CDGM-1.5	101 017 210 0901	CDGF-1.5	101 017 220 0901
CDGM-2.5	101 017 210 1001	CDGF-2.5	101 017 220 1001

Wire gauge	Designation	Order No.
0.14-4mm <sup>2</sup>	TL02G	198 001 001 0011

For the crimping contacts and removing contacts instructions, please find the page 06-23~06-24.

Application	Designation	Order No.
for crimp contacts 10A	TL00	198 001 000 0001

More tools detail please find the page 32-03~32-06.

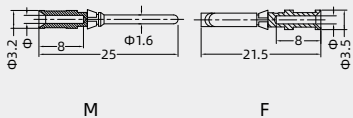

Wire gauge	$\phi$	Stripping length
0.09-0.25 mm <sup>2</sup>	0.65	5 mm
0.14-0.37 mm <sup>2</sup>	0.9	8 mm
0.5 mm <sup>2</sup>	1.1	8 mm
0.75 mm <sup>2</sup>	1.3	8 mm
1 mm <sup>2</sup>	1.45	8 mm
1.5 mm <sup>2</sup>	1.75	8 mm
2.5 mm <sup>2</sup>	2.25	6 mm

When the wire gauge is less than 0.75mm<sup>2</sup>,it's better to use the auxiliary pin assembly tool TL15.

Notes: The tools for crimp terminal may influence the product quality and stability.  
Please select the tools recognized by our company.

# HDD-072 Ultra-high density inserts

250V 10A 72+



## Inserts

Hoods/Housings: size 16B, please find the details on page 15-70~15-1071.

### Crimp terminal

order crimp contacts separately



Insert	Designation	Order No.
Male	HDD-072-MC <sup>1)</sup>	126 072 010 0001
Female	HDD-072-FC <sup>1)</sup>	126 072 020 0001

1). Can match PCB adapter, see page 14-02~14-03.

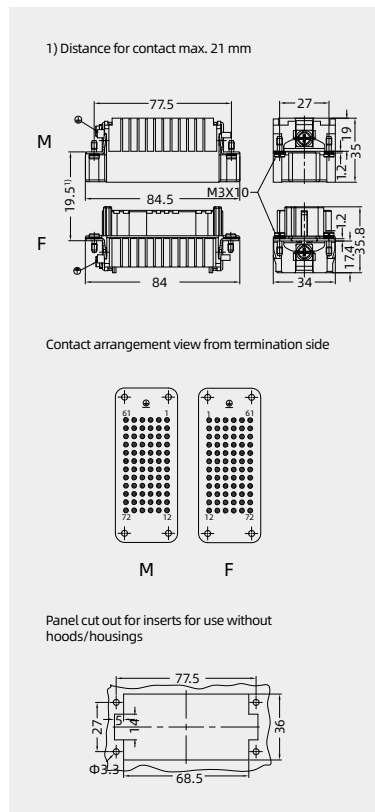

## Crimp contacts

### Crimp contacts 10A

Contact resistance  $\leq 3m\Omega$   
silver plated



gold plated



More crimp contacts 10A  
see P13-02, P13-03.

Male	Order No.	Female	Order No.
CDSM-0.25	101 017 110 0101	CDSF-0.25	101 017 120 0101
CDSM-0.37	101 017 110 0301	CDSF-0.37	101 017 120 0301
CDSM-0.50	101 017 110 0401	CDSF-0.50	101 017 120 0401
CDSM-0.75	101 017 110 0601	CDSF-0.75	101 017 120 0601
CDSM-1.0	101 017 110 0801	CDSF-1.0	101 017 120 0801
CDSM-1.5	101 017 110 0901	CDSF-1.5	101 017 120 0901
CDSM-2.5	101 017 110 1001	CDSF-2.5	101 017 120 1001
CDGM-0.25	101 017 210 0101	CDGF-0.25	101 017 220 0101
CDGM-0.37	101 017 210 0301	CDGF-0.37	101 017 220 0301
CDGM-0.50	101 017 210 0401	CDGF-0.50	101 017 220 0401
CDGM-0.75	101 017 210 0601	CDGF-0.75	101 017 220 0601
CDGM-1.0	101 017 210 0801	CDGF-1.0	101 017 220 0801
CDGM-1.5	101 017 210 0901	CDGF-1.5	101 017 220 0901
CDGM-2.5	101 017 210 1001	CDGF-2.5	101 017 220 1001

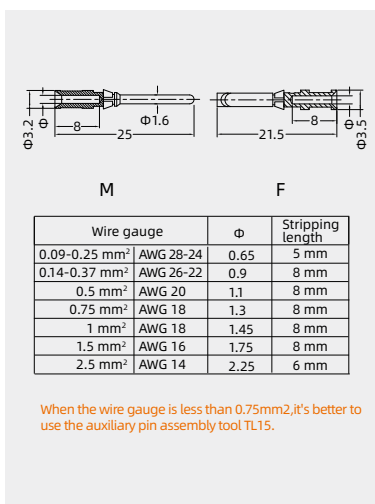

### Tools

Crimping tool



Contact removal tool



Wire gauge	Designation	Order No.
0.14-4mm <sup>2</sup>	TL02G	198 001 001 0011
For the crimping contacts and removing contacts instructions, please find the page 06-23~06-24.		
Application	Designation	Order No.
for crimp contacts 10A	TL00	198 001 000 0001

More tools detail please find the page 32-03~32-06.

Notes: The tools for crimp terminal may influence the product quality and stability.  
Please select the tools recognized by our company.

## HDD-108 Ultra-high density inserts

250V 10A 108+



### Inserts

Hoods/Housings: size 24B, please find the details on page 15-108~15-150.

#### Crimp terminal

order crimp contacts separately



Insert	Designation	Order No.
Male	HDD-108-MC <sup>1)</sup>	126 108 010 0001
Female	HDD-108-FC <sup>1)</sup>	126 108 020 0001

<sup>1)</sup>Can match PCB adapter,see page 14-02~14-03.

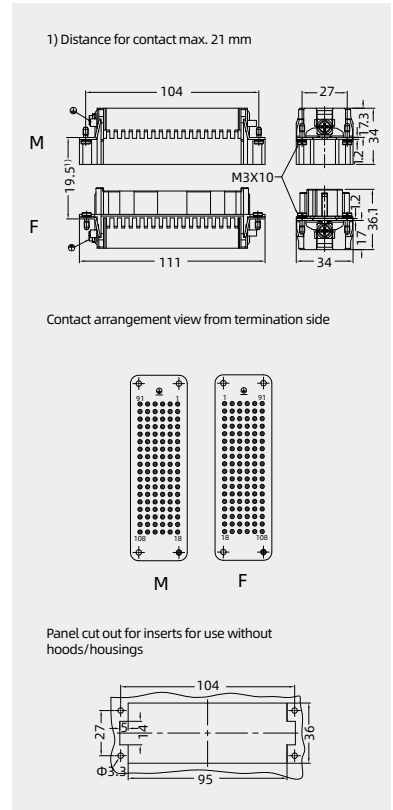

## Crimp contacts

### Crimp contacts 10A

Contact resistance  $\leq 3m\Omega$   
silver plated



gold plated



More crimp contacts 10A  
see P13-02,P13-03.

#### Tools

Crimping tool



Contact removal tool

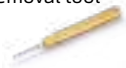

Male	Order No.	Female	Order No.
CDSM-0.25	101 017 110 0101	CDSF-0.25	101 017 120 0101
CDSM-0.37	101 017 110 0301	CDSF-0.37	101 017 120 0301
CDSM-0.50	101 017 110 0401	CDSF-0.50	101 017 120 0401
CDSM-0.75	101 017 110 0601	CDSF-0.75	101 017 120 0601
CDSM-1.0	101 017 110 0801	CDSF-1.0	101 017 120 0801
CDSM-1.5	101 017 110 0901	CDSF-1.5	101 017 120 0901
CDSM-2.5	101 017 110 1001	CDSF-2.5	101 017 120 1001

Male	Order No.	Female	Order No.
CDGM-0.25	101 017 210 0101	CDGF-0.25	101 017 220 0101
CDGM-0.37	101 017 210 0301	CDGF-0.37	101 017 220 0301
CDGM-0.50	101 017 210 0401	CDGF-0.50	101 017 220 0401
CDGM-0.75	101 017 210 0601	CDGF-0.75	101 017 220 0601
CDGM-1.0	101 017 210 0801	CDGF-1.0	101 017 220 0801
CDGM-1.5	101 017 210 0901	CDGF-1.5	101 017 220 0901
CDGM-2.5	101 017 210 1001	CDGF-2.5	101 017 220 1001

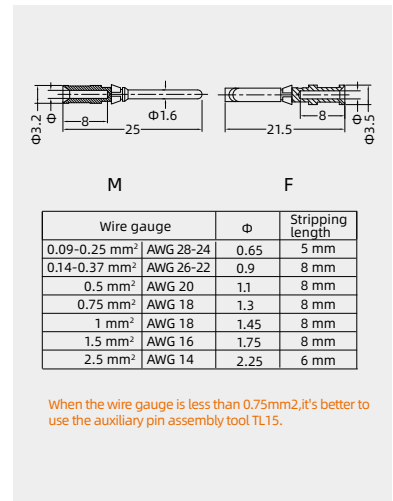

Notes: The tools for crimp terminal may influence the product quality and stability.  
Please select the tools recognized by our company.

## HDD-108 Ultra-high density inserts

200V 7.5A 108+ 

## Inserts

Hoods/Housings: This kind of insert only match with W24B-RBK housing

Soldered PCB connection



Insert	Designation	Order No.
Male	HDD-108-MSHT	126 108 013 1001

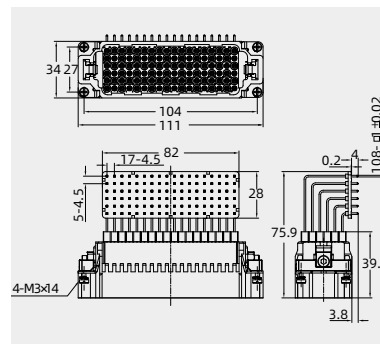

## Bulkhead Mounted Housings

(Assemble the inserts in reverse direction)



Thread	Designation	Order No.
---	W24B-RBK-2L/SC	111 124 341 1003

Please refer to page 15-02 for choosing proper model of lock.

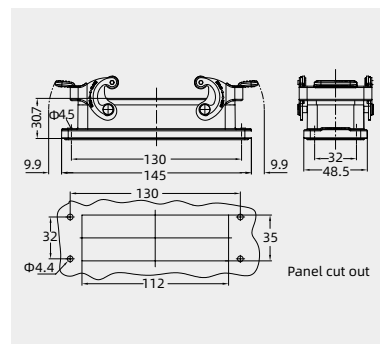

## Product features

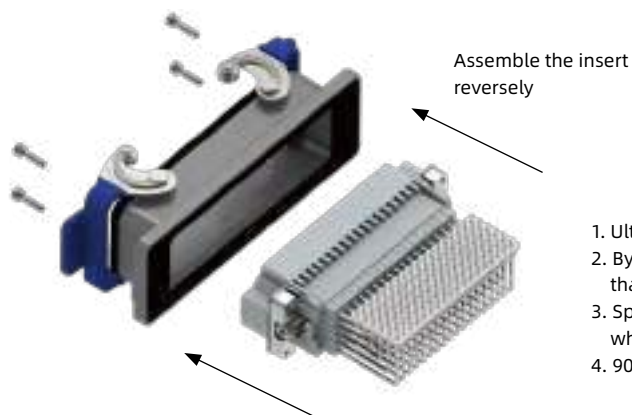

1. Ultra-high density insert: 108pin.
2. By welding manner, the assembly efficiency is much higher than the traditional wiring methods.
3. Specially designed housing makes sure that the insert can be assembled in reverse, which is convenient for installation and maintenance in practical application.
4. 90 degree pcb soldering termination design, quick and convenient.

## HDD-144 Ultra-high density inserts

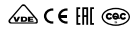
250V 10A 144+ 

## Inserts

Hoods/Housings: size 32B, please find the details on page 15-151~15-159.

## Crimp terminal

order crimp contacts separately



Insert	Designation	Order No.
Male	HDD-072-MC <sup>1)</sup>	126 072 010 0001
	HDD-072-MC(73-144) <sup>1)</sup>	126 072 010 0002
Female	HDD-072-FC <sup>1)</sup>	126 072 020 0001
	HDD-072-FC(73-144) <sup>1)</sup>	126 072 020 0002

1). Can match PCB adapter, see page 14-02-14-03.

1) Distance for contact max. 21 mm

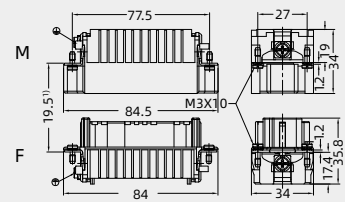

Contact arrangement view from termination side

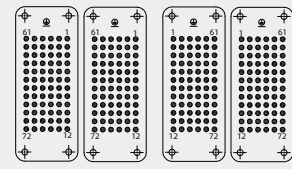

M

F

Panel cut out for inserts for use without hoods/housings

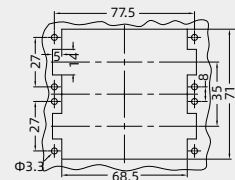

## Crimp contacts

## Crimp contacts 10A

Contact resistance  $\leq 3m\Omega$   
silver plated

gold plated

More crimp contacts 10A  
see P13-02, P13-03.

## Tools

## Crimping tool



## Contact removal tool

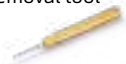

Male	Order No.	Female	Order No.
CDSM-0.25	101 017 110 0101	CDSF-0.25	101 017 120 0101
CDSM-0.37	101 017 110 0301	CDSF-0.37	101 017 120 0301
CDSM-0.50	101 017 110 0401	CDSF-0.50	101 017 120 0401
CDSM-0.75	101 017 110 0601	CDSF-0.75	101 017 120 0601
CDSM-1.0	101 017 110 0801	CDSF-1.0	101 017 120 0801
CDSM-1.5	101 017 110 0901	CDSF-1.5	101 017 120 0901
CDSM-2.5	101 017 110 1001	CDSF-2.5	101 017 120 1001

Male	Order No.	Female	Order No.
CDGM-0.25	101 017 210 0101	CDGF-0.25	101 017 220 0101
CDGM-0.37	101 017 210 0301	CDGF-0.37	101 017 220 0301
CDGM-0.50	101 017 210 0401	CDGF-0.50	101 017 220 0401
CDGM-0.75	101 017 210 0601	CDGF-0.75	101 017 220 0601
CDGM-1.0	101 017 210 0801	CDGF-1.0	101 017 220 0801
CDGM-1.5	101 017 210 0901	CDGF-1.5	101 017 220 0901
CDGM-2.5	101 017 210 1001	CDGF-2.5	101 017 220 1001

Wire gauge	Designation	Order No.
0.14-4mm <sup>2</sup>	TL02G	198 001 001 0011

For the crimping contacts and removing contacts instructions, please find the page 06-23-06-24.

Application	Designation	Order No.
for crimp contacts 10A	TL00	198 001 000 0001

More tools detail please find the page 32-03~32-06.

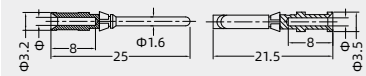

M

F

Wire gauge	$\phi$	Stripping length
0.09-0.25 mm <sup>2</sup>	AWG 28-24	0.65
0.14-0.37 mm <sup>2</sup>	AWG 26-22	0.9
0.5 mm <sup>2</sup>	AWG 20	1.1
0.75 mm <sup>2</sup>	AWG 18	1.3
1 mm <sup>2</sup>	AWG 18	1.45
1.5 mm <sup>2</sup>	AWG 16	1.75
2.5 mm <sup>2</sup>	AWG 14	2.25

When the wire gauge is less than 0.75mm<sup>2</sup>, it's better to use the auxiliary pin assembly tool TL15.Notes: The tools for crimp terminal may influence the product quality and stability.  
Please select the tools recognized by our company.



# HDD-216 Ultra-high density inserts

250V 10A 216+



## Inserts

Hoods/Housings: size 48B, please find the details on page 15-160~15-162.

### Crimp terminal

order crimp contacts separately



Insert	Designation	Order No.
Male	HDD-108-MC <sup>1)</sup>	126 108 010 0001
	HDD-108-MC(109-216) <sup>1)</sup>	126 108 010 0002
Female	HDD-108-FC <sup>1)</sup>	126 108 020 0001
	HDD-108-FC(109-216) <sup>1)</sup>	126 108 020 0002

1).Can match PCB adapter,see page 14-02~14-03.

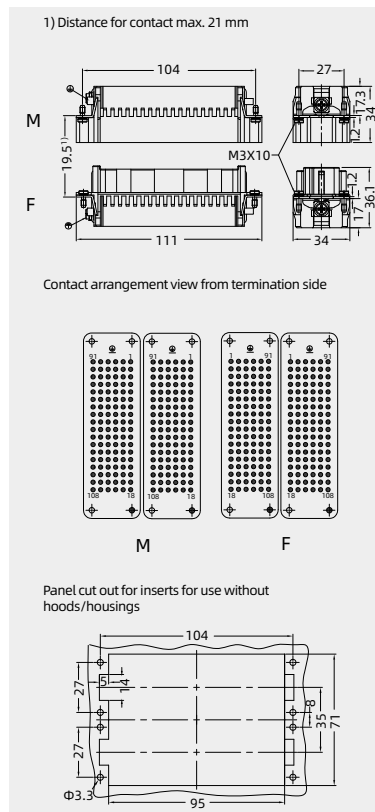

## Crimp contacts

### Crimp contacts 10A

Contact resistance  $\leq 3m\Omega$   
silver plated



gold plated



Male	Order No.	Female	Order No.
CDSM-0.25	101 017 110 0101	CDSF-0.25	101 017 120 0101
CDSM-0.37	101 017 110 0301	CDSF-0.37	101 017 120 0301
CDSM-0.50	101 017 110 0401	CDSF-0.50	101 017 120 0401
CDSM-0.75	101 017 110 0601	CDSF-0.75	101 017 120 0601
CDSM-1.0	101 017 110 0801	CDSF-1.0	101 017 120 0801
CDSM-1.5	101 017 110 0901	CDSF-1.5	101 017 120 0901
CDSM-2.5	101 017 110 1001	CDSF-2.5	101 017 120 1001
CDGM-0.25	101 017 210 0101	CDGF-0.25	101 017 220 0101
CDGM-0.37	101 017 210 0301	CDGF-0.37	101 017 220 0301
CDGM-0.50	101 017 210 0401	CDGF-0.50	101 017 220 0401
CDGM-0.75	101 017 210 0601	CDGF-0.75	101 017 220 0601
CDGM-1.0	101 017 210 0801	CDGF-1.0	101 017 220 0801
CDGM-1.5	101 017 210 0901	CDGF-1.5	101 017 220 0901
CDGM-2.5	101 017 210 1001	CDGF-2.5	101 017 220 1001

More crimp contacts 10A  
see P13-02,P13-03.

### Tools

Crimping tool



Contact removal tool

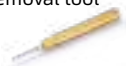

Wire gauge	Designation	Order No.
0.14-4mm <sup>2</sup>	TL02G	198 001 001 0011

For the crimping contacts and removing contacts instructions, please find the page 06-23-06-24.

Application	Designation	Order No.
for crimp contacts 10A	TL00	198 001 000 0001

More tools detail please find the page 32-03~32-06.

Notes: The tools for crimp terminal may influence the product quality and stability.  
Please select the tools recognized by our company.

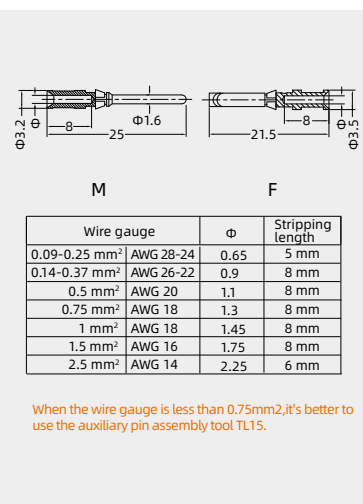

# HDDD-055 Ultra-high density inserts

250V 10A 55+



## Inserts

Hoods/Housings: size 16B, please find the details on page 15-39-15-69.

### Crimp terminal

order crimp contacts separately



Insert	Designation	Order No.
Male	HDDD-055/0-MC	145 055 010 0500
Female	HDDD-055/0-FC	145 055 020 0500

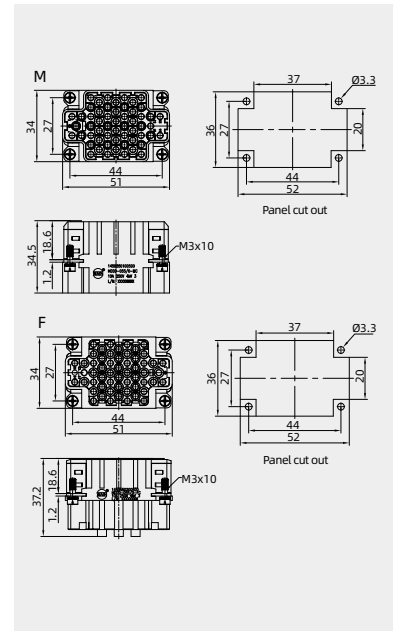

## Crimp contacts

### Crimp contacts 10A

Contact resistance  $\leq 3m\Omega$   
silver plated



gold plated



More crimp contacts 10A  
see P13-02,P13-03.

### Tools

Crimping tool



Contact removal tool

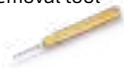

Male	Order No.	Female	Order No.
CDSM-0.25	101 017 110 0101	CDSF-0.25	101 017 120 0101
CDSM-0.37	101 017 110 0301	CDSF-0.37	101 017 120 0301
CDSM-0.50	101 017 110 0401	CDSF-0.50	101 017 120 0401
CDSM-0.75	101 017 110 0601	CDSF-0.75	101 017 120 0601
CDSM-1.0	101 017 110 0801	CDSF-1.0	101 017 120 0801
CDSM-1.5	101 017 110 0901	CDSF-1.5	101 017 120 0901
CDSM-2.5	101 017 110 1001	CDSF-2.5	101 017 120 1001

	Order No.		Order No.
CDGM-0.25	101 017 210 0101	CDGF-0.25	101 017 220 0101
CDGM-0.37	101 017 210 0301	CDGF-0.37	101 017 220 0301
CDGM-0.50	101 017 210 0401	CDGF-0.50	101 017 220 0401
CDGM-0.75	101 017 210 0601	CDGF-0.75	101 017 220 0601
CDGM-1.0	101 017 210 0801	CDGF-1.0	101 017 220 0801
CDGM-1.5	101 017 210 0901	CDGF-1.5	101 017 220 0901
CDGM-2.5	101 017 210 1001	CDGF-2.5	101 017 220 1001

Wire gauge	Designation	Order No.
0.14-4mm <sup>2</sup>	TL02G	198 001 001 0011

For the crimping contacts and removing contacts  
instructions, please find the page 06-23-06-24.

Application	Designation	Order No.
for crimp contacts 10A	TL00	198 001 000 0001

More tools detail please find the page 32-03~32-06.

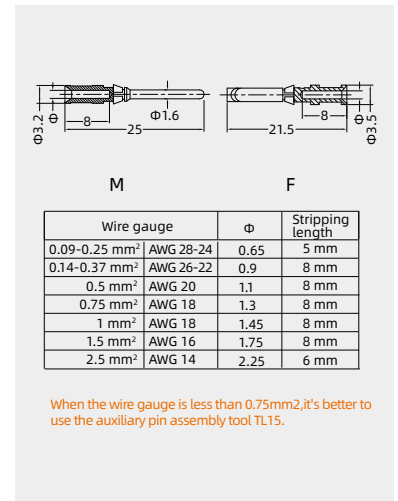

When the wire gauge is less than 0.75mm<sup>2</sup>, it's better to  
use the auxiliary pin assembly tool TL15.

Notes: The tools for crimp terminal may influence the product quality and stability.  
Please select the tools recognized by our company.

# Assembly and removal instructions of D Crimp contact

## Assembly

1.Stripped wire,reference length 8 mm;

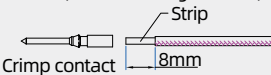

2.Push the wire into the wire guide hole, and crimp;

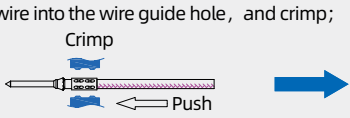

3.Push the terminal into the socket;

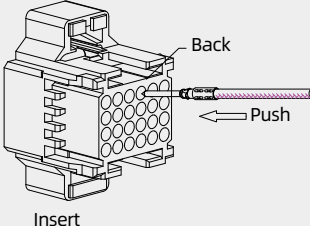

4.Push the terminal at the bottom of hole until heard a 'tick'!

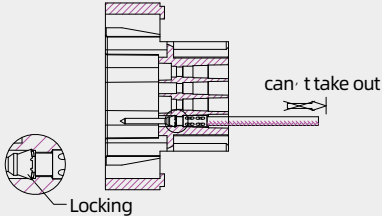

### Crimp contact

1.insert the wire into Crimp contact.

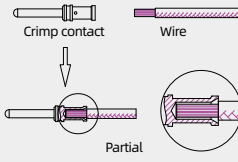

Attention: The pinhole and the wire must match, otherwise it might cause a difficulty during installing wire or a loose connection.

2.Insert the contact into the appropriate tooth.

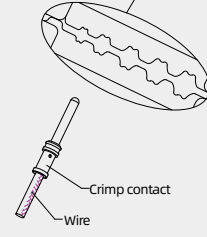

3.Press tightly

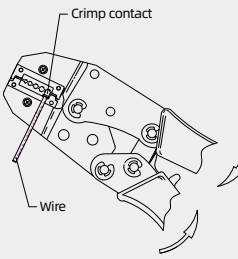

4.loosen the Crimping tool,take out the crimp contact

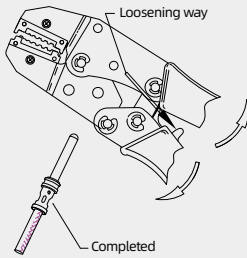

Notes: The tools for crimp terminal may influence the product quality and stability. Please select the tools recognized by our company.

## Removal

1. Pull the tool into the hole of terminal as shown in the figure.

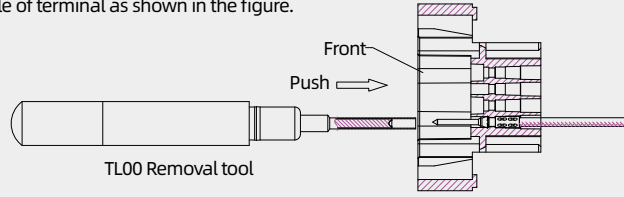

2. Push the tool at the bottom of hole, then spring the terminal.

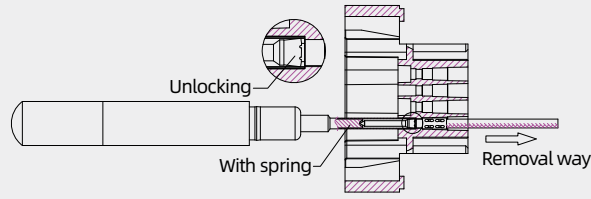

3. Removal the terminal.

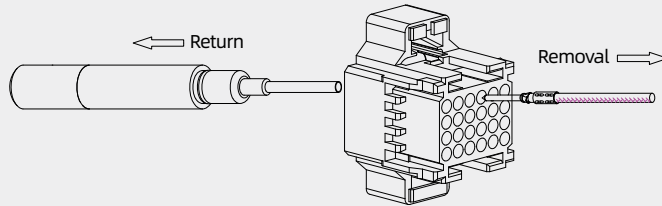



HD  
HDD

# HSB SERIES

35A heavy-current connector



# HSB SERIES Heavy-current inserts

## Technical characteristics

Technical characteristics	DIN EN 60 664 DIN EN 61 984
Approvals	
<b>Inserts</b>	
Number of contacts	6,12+PE
<b>Electrical data acc. to EN 61 984</b>	
-Rated current	35A
-Rated voltage conductor - ground	400V
-Rated voltage conductor - conductor	690V
-Rated impulse voltage	6kV
-Pollution degree	3
-or	35A 500V 6kV 3
Rated voltage acc. to UL	600V
Insulation resistance	$\geq 10^{10}\Omega$
Material	polycarbonate
Limiting temperatures	-40°C ... +125°C
Flammability acc. to UL 94	V0
Mechanical working life(mating cycles)	$\geq 500$
<b>Contacts</b>	
Material	copper alloy
Surface	hard-silver plated
Contact resistance	$\leq 1m\Omega$
<b>Screw terminal</b>	
- Wire gauge	1.5-6mm <sup>2</sup>
- AWG	10
- Tightening torque	1.2Nm

## Current carrying capacity

The current carrying is limited by maximum temperature of materials for inserts and contacts including terminals

Control and test procedures according to DIN EN 60512-5

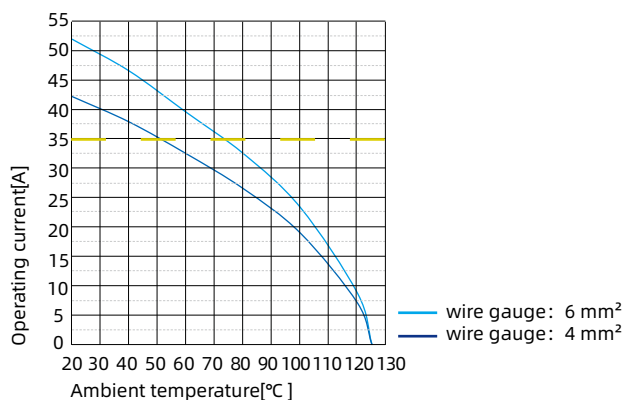

# HSB-006 Heavy-current inserts

400/690V 35A 6+⊕



## Inserts

Hoods/Housings: size 16B, please find the details on page 15-70~15-1071.

### Screw terminal



Insert	Designation	Order No.
Male	HSB-006-M	127 006 011 0001
Female	HSB-006-F	127 006 021 0001

1) Distance for contact max. 21 mm

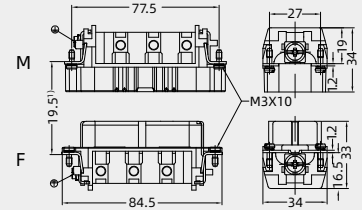

Contact arrangement view from termination side

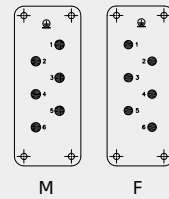

Panel cut out for inserts for use without hoods/housings

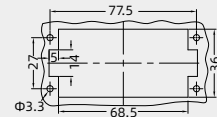



# HSB-012 Heavy-current inserts

400/690V 35A 12+ 



## Inserts

Hoods/Housings: size **32B**, please find the details on page 15-151~15-159.

### Screw terminal



Insert	Designation	Order No.
Male	HSB-006-M	127 006 011 0001
	HSB-006-M(7-12)	127 006 011 0002
Female	HSB-006-F	127 006 021 0001
	HSB-006-F(7-12)	127 006 021 0002

1) Distance for contact max. 21 mm

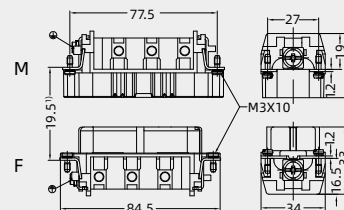

Contact arrangement view from termination side

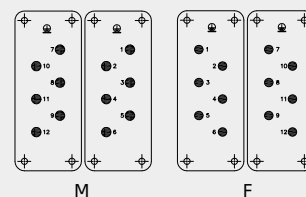

Panel cut out for inserts for use without hoods/housings

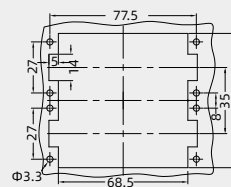

## HSB-004/2 Heavy-current inserts(Quick-in)

### Technical characteristics

Technical characteristics	DIN EN 60 664 DIN EN 61 984
---------------------------	--------------------------------

#### Approvals

#### Inserts

Number of contacts	4/2+PE
--------------------	--------

#### Electrical data acc. to EN 61 984

-Rated current	40A/16A
-Rated voltage conductor - ground	690V/500V
-Rated impulse voltage	6kV/6kV
-Pollution degree	3
-Insulation resistance	$\geq 10^{10}\Omega$
Material	polycarbonate
Colour	RAL 7032(light grey)
Limiting temperatures	-40°C ...+125°C
Flammability acc. to UL 94	V0
Mating cycles	$\geq 500$

#### Contacts

Terminal	spring terminal(Quick-in)
Material	copper alloy
Surface	hard-silver plated
Contact resistance	$\leq 3m\Omega$
Wire gauge	0.5-2.5mm <sup>2</sup> (20-14AWG) 0.5-6mm <sup>2</sup> (20-10AWG)
Stripping length	12.5mm/12mm

HSB-004/2 Heavy-current inserts(Quick-in)

690/500V 40/16A 4/2+ 

Inserts

Hoods/Housings: size 16B, please find the details on page 15-70~15-1071.

Spring terminal(Quick-in)



Insert	Designation	Order No.
Male	HSB-004/2-MQ	127 006 001 0001
Female	HSB-004/2-FQ	127 006 002 0001

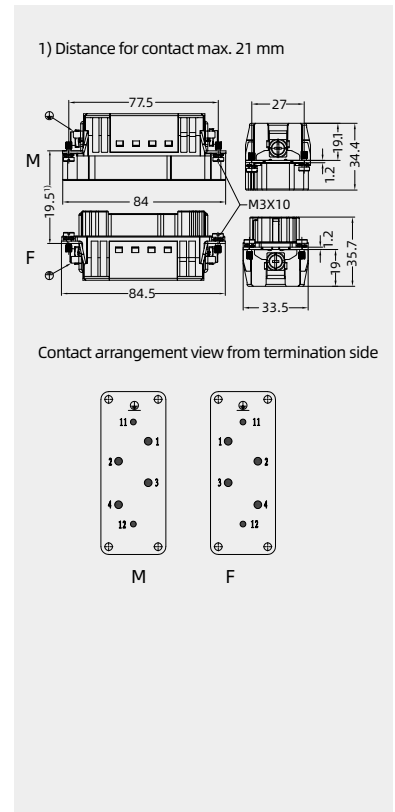



HSB

## HK SERIES

Combination connector

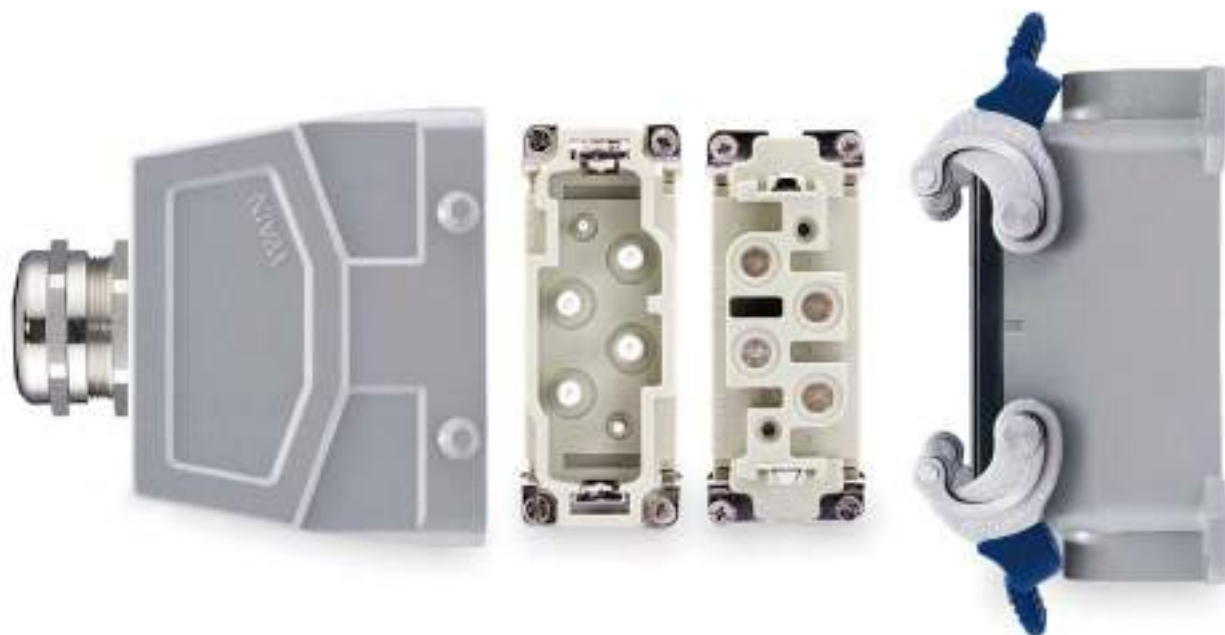

## HK-008/24 Combination inserts



### Technical characteristics

Specifications	DIN EN 60 664 DIN EN 61 984
Approvals	UL VDE CE ENEC CCC
Inserts	
Number of contacts	8/24+PE
Electrical data acc. to EN 61 984	
Power area	
-Rated current	16A
-Rated voltage conductor	400V
-Rated impulse voltage	6kV
-Pollution degree	3
Signal area	
-Rated current	10A
-Rated voltage	250V
-Rated impulse voltage	4kV
-Pollution degree	3
Rated voltage acc. to UL	600/300V
Insulation resistance	$\geq 10^{10}\Omega$
Material	polycarbonate
Limiting temperatures	-40°C ... +125°C
Flammability acc. to UL 94	V0
Mechanical working life (mating cycles)	$\geq 500$
Contacts	
Power contacts	
-Material	copper alloy
-Surface	hard-silver plated hard-gold plated
-Contact resistance	$\leq 1\text{m}\Omega$
-Crimp terminal	
-mm <sup>2</sup>	0.5-4mm <sup>2</sup>
-AWG	20-12
Signal contacts	
-Material	copper alloy
-Surface	hard-silver plated hard-gold plated
-Contact resistance	$\leq 3\text{m}\Omega$
-Crimp terminal	
-mm <sup>2</sup>	0.14-2.5mm <sup>2</sup>
-AWG	25-14

### Current carrying capacity

The current carrying is limited by maximum temperature of materials for inserts and contacts including terminals

Control and test procedures according to DIN EN 60512-5

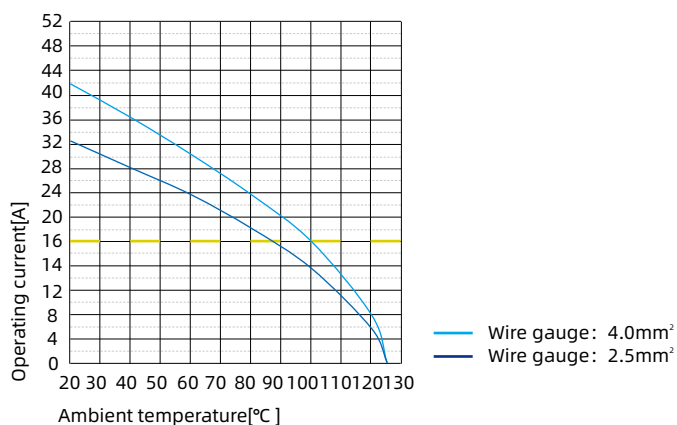

# HK-008/24 Combination inserts

400/250V 16/10A 8/24+



## Inserts

Hoods/Housings: size 10B, please find the details on page 15-39~15-69.

### Crimp terminal

order crimp contacts separately



Insert	Designation	Order No.
Male	HK-008/24-MC	128 032 010 0001
Female	HK-008/24-FC	128 032 020 0001

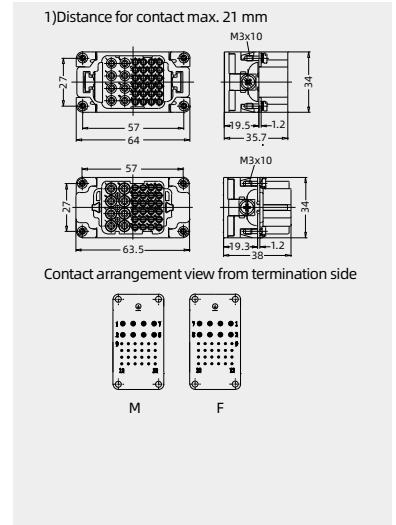

## Crimp contacts

### Crimp contacts 10A

Contact resistance  $\leq 3m\Omega$   
silver plated



gold plated



More crimp contacts 10A see P13-02, P13-03.

Male	Order No.	Female	Order No.
CDSM-0.25	101 017 110 0101	CDSF-0.25	101 017 120 0101
CDSM-0.37	101 017 110 0301	CDSF-0.37	101 017 120 0301
CDSM-0.50	101 017 110 0401	CDSF-0.50	101 017 120 0401
CDSM-0.75	101 017 110 0601	CDSF-0.75	101 017 120 0601
CDSM-1.0	101 017 110 0801	CDSF-1.0	101 017 120 0801
CDSM-1.5	101 017 110 0901	CDSF-1.5	101 017 120 0901
CDSM-2.5	101 017 110 1001	CDSF-2.5	101 017 120 1001
CDGM-0.25	101 017 210 0101	CDGF-0.25	101 017 220 0101
CDGM-0.37	101 017 210 0301	CDGF-0.37	101 017 220 0301
CDGM-0.50	101 017 210 0401	CDGF-0.50	101 017 220 0401
CDGM-0.75	101 017 210 0601	CDGF-0.75	101 017 220 0601
CDGM-1.0	101 017 210 0801	CDGF-1.0	101 017 220 0801
CDGM-1.5	101 017 210 0901	CDGF-1.5	101 017 220 0901
CDGM-2.5	101 017 210 1001	CDGF-2.5	101 017 220 1001

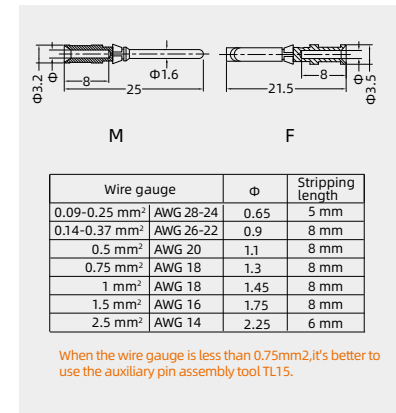

### Crimp contacts 16A

silver plated



gold plated



More crimp contacts 16A see P13-04.

Male	Order No.	Female	Order No.
CESM-0.37	101 019 110 0301	CESF-0.37	101 019 120 0301
CESM-0.50	101 019 110 0401	CESF-0.50	101 019 120 0401
CESM-0.75	101 019 110 0601	CESF-0.75	101 019 120 0601
CESM-1.0	101 019 110 0801	CESF-1.0	101 019 120 0801
CESM-1.5	101 019 110 0901	CESF-1.5	101 019 120 0901
CESM-2.5	101 019 110 1001	CESF-2.5	101 019 120 1001
CESM-3.0	101 019 110 1101	CESF-3.0	101 019 120 1101
CESM-4.0	101 019 110 1201	CESF-4.0	101 019 120 1201
CEGM-0.37	101 019 210 0301	CEGF-0.37	101 019 220 0301
CEGM-0.50	101 019 210 0401	CEGF-0.50	101 019 220 0401
CEGM-0.75	101 019 210 0601	CEGF-0.75	101 019 220 0601
CEGM-1.0	101 019 210 0801	CEGF-1.0	101 019 220 0801
CEGM-1.5	101 019 210 0901	CEGF-1.5	101 019 220 0901
CEGM-2.5	101 019 210 1001	CEGF-2.5	101 019 220 1001
CEGM-3.0	101 019 210 1101	CEGF-3.0	101 019 220 1101
CEGM-4.0	101 019 210 1201	CEGF-4.0	101 019 220 1201

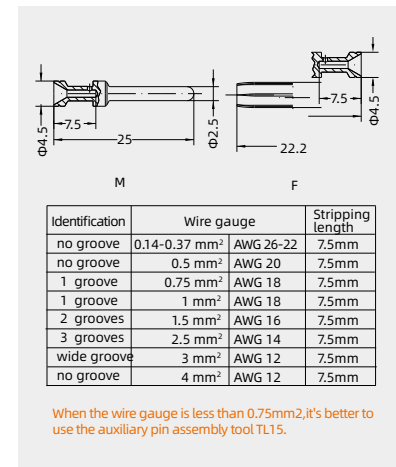

### Tools

Crimping tool



Contact removal tool



Wire gauge	Designation	Order No.
0.14-4mm <sup>2</sup>	TL02G	198 001 001 0011
Wire gauge: 16A crimp contacts 0.14-0.37mm <sup>2</sup> please select TL02 crimping tool.		
Application	Designation	Order No.
for crimp contacts 10A	TL00	198 001 000 0001
16A contact removal tool: cross-slotted screw driver( size 0 acc. to DIN 5260).		

Notes: The tools for crimp terminal may influence the product quality and stability. Please select the tools recognized by our company.

## HK-004/4 Combination crimp inserts

### Technical characteristics

Specifications	DIN EN 60 664 DIN EN 61 984
Approvals	
Inserts	C € ERI
Number of contacts	4/4+PE
Electrical data acc. to EN 61 984	
Power area	
-Rated current	70A
-Rated voltage	690V
-Rated impulse voltage	8kV
-Pollution degree	3
Signal area	
-Rated current	16A
-Rated voltage	250V
-Rated impulse voltage	4kV
-Pollution degree	3
Rated voltage acc. to UL	600/230V
Insulation resistance	$\geq 10^{10}\Omega$
Material	polycarbonate
Limiting temperatures	-40°C ...+125°C
Flammability acc. to UL 94	V0
Mechanical working life (mating cycles)	$\geq 500$
Contacts	
Power contacts	
-Material	copper alloy
-Surface	hard-silver plated
-Contact resistance	$\leq 0.5m\Omega$
-Crimp terminal	
- wire gauge	10-25mm <sup>2</sup>
-Max. insulation diameter	11mm
Stripping length	15.5mm
Signal contacts	
-Material	copper alloy
-Surface	hard-silver plated
-Contact resistance	$\leq 1m\Omega$
-Crimp terminal	
-mm <sup>2</sup>	0.14-4mm <sup>2</sup>
-AWG	26-12

### Current carrying capacity

The current carrying is limited by maximum temperature of materials for inserts and contacts including terminals

Control and test procedures according to DIN EN 60512-5

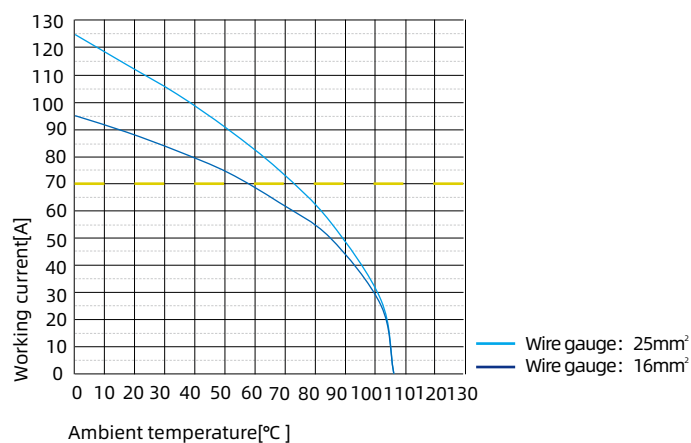



# HK-004/4 Combination crimp inserts

690/250V 70/16A 4/4+⊕

CE

## Inserts

Hoods/Housings: size 10B, please find the details on page 15-39~15-69.

### Crimp terminal

order crimp contacts separately



Insert	Designation	Order No.
Male	HK-004/4-MC	128 008 010 0001
Female	HK-004/4-FC	128 008 020 0001

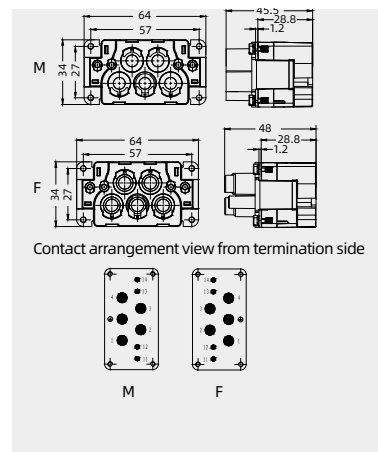

Contact arrangement view from termination side

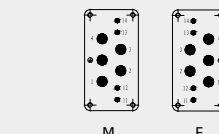

## Crimp contacts

### Crimp contacts 70A

silver plated

Contact resistance ≤ 0.5mΩ



PE Contact



Male	Order No.	Female	Order No.
CKSM70-6	101 034 110 1301	CKSF70-6	101 034 120 1301
CKSM70-10	101 034 110 1401	CKSF70-10	101 034 120 1401
CKSM70-16	101 034 110 1501	CKSF70-16	101 034 120 1501
CKSM70-25	101 034 110 1601	CKSF70-25	101 034 120 1601
CKSM70PE-10	101 034 110 1404	CKSF70PE-10	101 034 120 1404
CKSM70PE-16	101 034 110 1504	CKSF70PE-16	101 034 120 1504
CKSM70PE-25	101 034 110 1604	CKSF70PE-25	101 034 120 1604

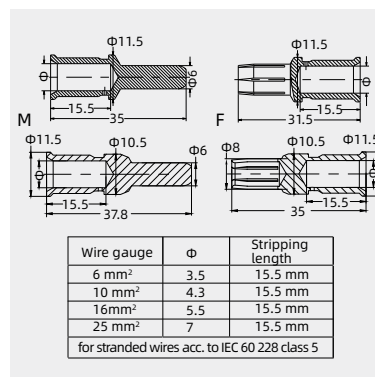

### Crimp contacts 16A

silver plated

Contact resistance ≤ 1mΩ



Male	Order No.	Female	Order No.
CESM-0.37	101 019 110 0301	CESF-0.37	101 019 120 0301
CESM-0.50	101 019 110 0401	CESF-0.50	101 019 120 0401
CESM-0.75	101 019 110 0601	CESF-0.75	101 019 120 0601
CESM-1.0	101 019 110 0801	CESF-1.0	101 019 120 0801
CESM-1.5	101 019 110 0901	CESF-1.5	101 019 120 0901
CESM-2.5	101 019 110 1001	CESF-2.5	101 019 120 1001
CESM-3.0	101 019 110 1101	CESF-3.0	101 019 120 1101
CESM-4.0	101 019 110 1201	CESF-4.0	101 019 120 1201

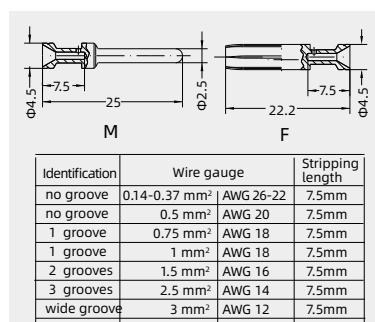

More crimp contacts 16A see P13-04.

### Tools

#### Manual hydraulic clamp



Wire gauge	Designation	Order No.
10-240mm <sup>2</sup>	TL05	198 001 001 0005

Remark: for wire gauge 6mm<sup>2</sup>, need to order 2980010010037 TL05 6C die separately.

#### Crimping tool



Wire gauge	Designation	Order No.
0.5-4mm <sup>2</sup>	TL02G	198 001 001 0011

Wire gauge:16A crimp contacts 0.14-0.37mm<sup>2</sup> please select TL02 crimping tool.

#### Contact removal tool



Application	Designation	Order No.
for crimp contacts 70A	TL12	198 001 000 0024
for crimp contacts 16A	TL01	198 001 000 0002

Notes: The tools for crimp terminal may influence the product quality and stability. Please select the tools recognized by our company.

## HK-004/4 Combination inserts



### Technical characteristics

Specifications	DIN EN 60 664 DIN EN 61 984
Approvals	
Inserts	
Number of contacts	4/4+PE
Electrical data acc. to EN 61 984	
Power area	
-Rated current	63A
-Rated voltage	690V
-Rated impulse voltage	8kV
-Pollution degree	3
Signal area	
-Rated current	16A
-Rated voltage	250V
-Rated impulse voltage	4kV
-Pollution degree	3
Rated voltage acc. to UL	600/230V
Insulation resistance	$\geq 10^{10}\Omega$
Material	polycarbonate
Limiting temperatures	-40°C ...+125°C
Flammability acc. to UL 94	V0
Mechanical working life(mating cycles)	$\geq 500$
Contacts	
Power contacts	
-Material	copper alloy
-Surface	hard-silver plated
-Contact resistance	$\leq 0.5m\Omega$
-Screw terminal	
- geometric wire gauge	6-22mm <sup>2</sup>
- AWG	8-4
-Max. insulation diameter	11mm
-Stripping length	11mm
Signal contacts	
-Material	copper alloy
-Surface	hard-silver plated
-Contact resistance	$\leq 3m\Omega$
-Spring terminal	
-mm <sup>2</sup>	0.14-2.5mm <sup>2</sup>
-AWG	26-14
-Stripping length	7-9mm

# HK-004/4 Combination inserts

690/250V 63/16A 4/4+⊕



## Inserts

Hoods/Housings: only suitable for size 10B high structure shells, please find the details on page 15-39~15-69.

### Screw terminal



Insert	Designation	Order No.
Male	HK-004/4.1-M(6-16mm <sup>2</sup> )	128 008 011 0002
	HK-004/4.2-M(14-22mm <sup>2</sup> )	128 008 011 0003
Female	HK-004/4.1-F(6-16mm <sup>2</sup> )	128 008 021 0002
	HK-004/4.2-F(14-22mm <sup>2</sup> )	128 008 021 0003

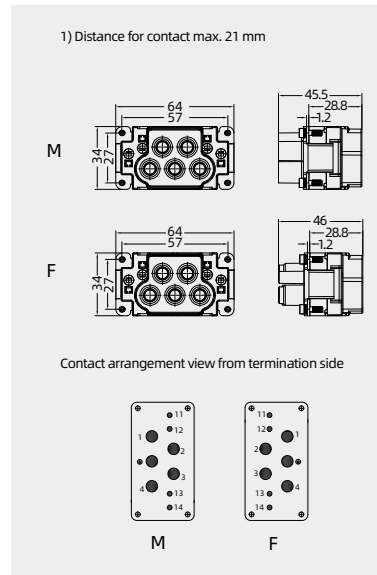

## Accessories

### Tool

hexagonal driver



Description	Designation	Order No.
for axial setscrew with grip	SW-2.5*100	198 001 003 0003

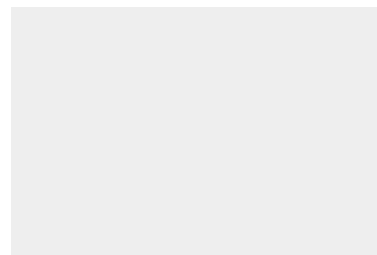

## HK-004/0,004/2 Combination inserts



### Technical characteristics

Specifications	DIN EN 60 664 DIN EN 61 984
Approvals	
Inserts	
Number of contacts	4/0+PE,4/2+PE
Electrical data acc. to EN 61 984	
Power area	
-Rated current	80A
-Rated voltage	830V
-Rated impulse voltage	8kV
-Pollution degree	3
-Pollution degree 2 also	80A 1000V 8kV 2
Signal area	
-Rated current	16A
-Rated voltage	400V
-Rated impulse voltage	6kV
-Pollution degree	3
-Pollution degree 2 also	16A 400/690V 6kV 2
Rated voltage acc. to UL	600/300V
Insulation resistance	$\geq 10^{10}\Omega$
Material	polycarbonate
Limiting temperatures	-40°C ...+125°C
Flammability acc. to UL 94	V0
Mechanical working life(mating cycles)	$\geq 500$
Contacts	
Power contacts	
-Material	copper alloy
-Surface	hard-silver plated
-Contact resistance	$\leq 0.3m\Omega$
-Screw terminal	
- geometric wire gauge	1.5-16mm <sup>2</sup>
- AWG	16-6
-Tightening torque	
-mm <sup>2</sup>	1.5 2.5 4 6 10 16
-N.m	1.2 2 3 3 3 3
-Stripping length	14mm
Signal contacts	
-Material	copper alloy
-Surface	hard-silver plated
-Contact resistance	$\leq 1m\Omega$
-Screw terminal	
-mm <sup>2</sup>	0.5-2.5mm <sup>2</sup>
-AWG	20-14
-Tightening torque	0.5Nm
-Stripping length	7.5mm

### Current carrying capacity

The current carrying is limited by maximum temperature of materials for inserts and contacts including terminals

Control and test procedures according to DIN EN 60512-5

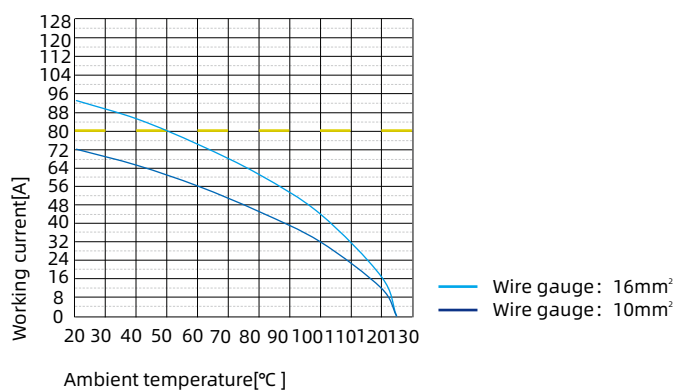

# HK-004/0,004/2 Combination inserts

830/400V 80/16A 4/0,4/2+⊕



## Inserts

Hoods/Housings: size 16B, please find the details on page 15-70~15-1071.

### Screw terminal



Insert	Designation	Order No.
Male	HK-004/0-M	128 004 011 0001
Female	HK-004/0-F	128 004 021 0001

### Screw terminal



Insert	Designation	Order No.
Male	HK-004/2-M	128 006 011 0001
Female	HK-004/2-F	128 006 021 0001

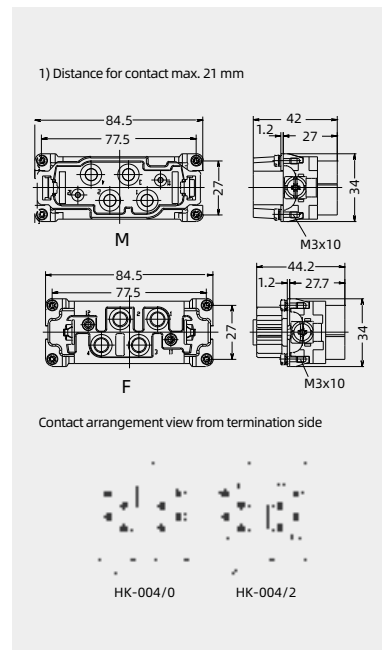

## HK-004/8 Combination inserts



### Technical characteristics

Specifications	DIN EN 60 664 DIN EN 61 984
Approvals	
Inserts	
Number of contacts	4/8+PE
Electrical data acc. to EN 61 984	
Power area	
-Rated current	80A
-Rated voltage	400V
-Rated impulse voltage	6kV
-Pollution degree	3
Signal area	
-Rated current	16A
-Rated voltage	400V
-Rated impulse voltage	6kV
-Pollution degree	3
Rated voltage acc. to UL	600/600V
Insulation resistance	$\geq 10^{10}\Omega$
Material	polycarbonate
Limiting temperatures	-40°C ...+125°C
Flammability acc. to UL 94	V0
Mechanical working life(mating cycles)	$\geq 500$
Contacts	
Power contacts	
-Material	copper alloy
-Surface	hard-silver plated
-Contact resistance	$\leq 0.3m\Omega$
-Screw terminal	
- geometric wire gauge	1.5-16mm <sup>2</sup>
- AWG	16-6
-Tightening torque	
-mm <sup>2</sup>	1.5 2.5 4 6 10 16
-N.m	1.2 2 3 3 3 3
-Stripping length	14mm
Signal contacts	
-Material	copper alloy
-Surface	hard-silver plated
-Contact resistance	$\leq 1m\Omega$
-Screw terminal	
-mm <sup>2</sup>	0.5-2.5mm <sup>2</sup>
-AWG	20-14
-Tightening torque	0.5Nm
-Stripping length	7.5mm

### Current carrying capacity

The current carrying is limited by maximum temperature of materials for inserts and contacts including terminals

Control and test procedures according to DIN EN 60512-5

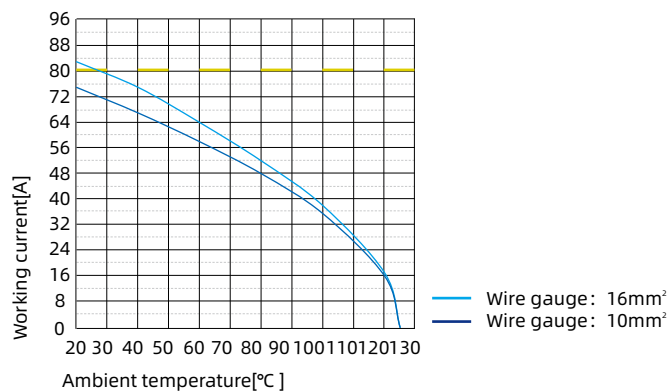

HK-004/8 Combination inserts

400/400V 80/16A 4/8+⊕



Inserts

Hoods/Housings: size 24B, please find the details on page 15-108-15-150.

Screw terminal



Insert	Designation	Order No.
Male	HK-004/8-M	128 012 011 0001
Female	HK-004/8-F	128 012 021 0001

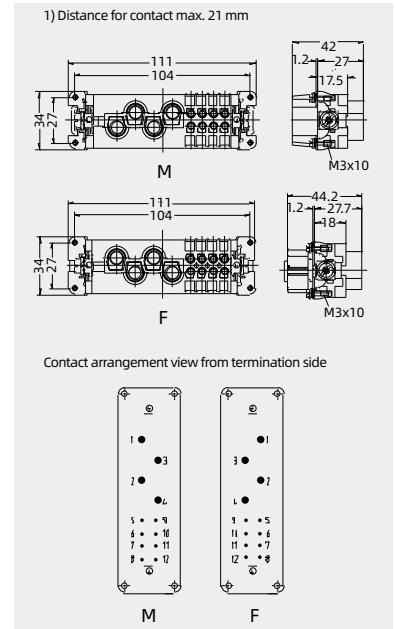

## HWK-006/6 Combination inserts



### Technical characteristics

Technical characteristics	DIN EN 60 664	DIN EN 61 984
Approvals		
Inserts		
Number of contacts	6/6+PE	
Electrical data acc. to EN 61 984		
Power area		
-Rated current	40A	
-Rated voltage	690V	
-Rated impulse voltage	8kV	
-Pollution degree	3	
Signal area		
-Rated current	16A	
-Rated voltage	400V	
-Rated impulse voltage	6kV	
-Pollution degree	3	
Rated voltage acc. to UL	600/600V	
Insulation resistanc	$\geq 10^{10}\Omega$	
Material	polycarbonate	
Limiting temperatures	-40°C ...+125°C	
Flammability acc. to UL 94	V0	
Mechanical working life(mating cycles)	$\geq 500$	
Contacts		
Material	copper alloy	
Surface	hard-silver plated	
Terminal	screw terminal	
Contact resistance		
-power area	$\leq 1\text{m}\Omega$	
-signal area	$\leq 1\text{m}\Omega$	
Wire gauge		
-power area		
-mm <sup>2</sup>	4-10mm <sup>2</sup>	
-AWG	12-8	
-signal area		
-mm <sup>2</sup>	1-2.5mm <sup>2</sup>	
-AWG	18-4	
Tightening torque		
-power area		
mm <sup>2</sup>	1.5	2.5 4 6 10
N.m	1.2	2 3 3 3
-signal area		
	0.5N.m	

### Current carrying capacity

The current carrying is limited by maximum temperature of materials for inserts and contacts including terminals

Control and test procedures according to DIN EN 60512-5

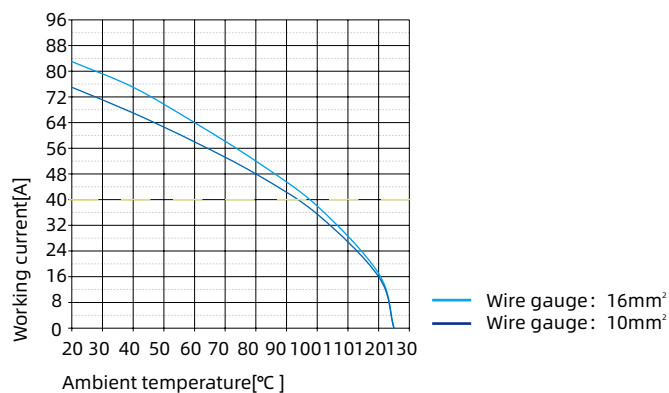



# HWK-006/6 Combination inserts

690/400V 40/16A 6/6+ 

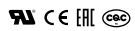

## Inserts

Hoods/Housings: size 16B, please find the details on page 15-70~15-1071.

### Screw terminal



Insert	Designation	Order No.
Male	HWK-006/6-M	128 012 011 0201
Female	HWK-006/6-F	128 012 021 0201

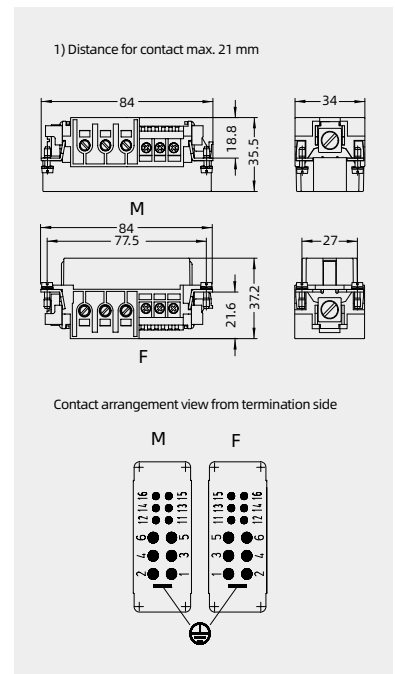

## HK-006/12 Combination inserts



### Technical characteristics

Specifications	DIN EN 60 664 DIN EN 61 984
Approvals	
Inserts	
Number of contacts	6/12+PE
Electrical data acc. to EN 61 984	
Power area	
Rated current	40A
Rated voltage	690V
Rated impulse voltage	6kV
Pollution degree	3
Signal area	
Rated current	10A
Rated voltage conductor	230/400V
Rated impulse voltage	4kV
Pollution degree	3
Rated voltage acc. to UL	600/300V
Insulation resistance	$\geq 10^{10}\Omega$
Material	polycarbonate
Limiting temperatures	-40°C ...+125°C
Flammability acc. to UL 94	V0
Mechanical working life(mating cycles)	$\geq 500$
<b>Contacts</b>	
Power contacts	
-Material	copper alloy
-Surface	hard-silver plated
-Contact resistance	$\leq 1m\Omega$
-Axial screw termination	
- geometric wire gauge	2.5-10mm <sup>2</sup>
- AWG	14-8
-Max. insulation diameter	6.1mm
-Tightening torque	
-mm <sup>2</sup>	2.5 4 6 10
-Nm	1.5 1.5 2 2
-Stripping length	
-mm <sup>2</sup>	2.5 4 6 10
-mm	5 <sup>+1</sup> 5 <sup>+1</sup> 8 <sup>+1</sup> 8 <sup>+1</sup>
Signal contacts	
-Material	copper alloy
-Surface	hard-silver plated
-Contact resistance	$\leq 3m\Omega$
-Screw terminal	
- geometric wire gauge	0.2-2.5mm <sup>2</sup>
- AWG	24-14
-Tightening torque	0.8Nm
-Stripping length	7.5mm

### Current carrying capacity

The current carrying is limited by maximum temperature of materials for inserts and contacts including terminals

Control and test procedures according to DIN EN 60512-5

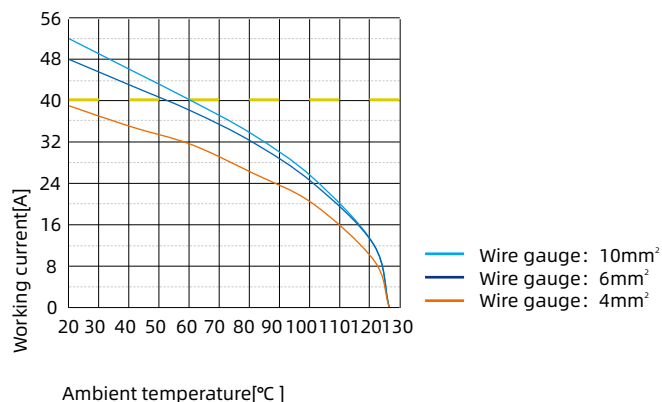

# HK-006/12 Combination inserts

690/400V 40/10A 6/12+ 



## Inserts

Hoods/Housings: size **16B**, please find the details on page 15-70~15-1071.

### Axial screw terminal<sup>1)</sup>/Screw terminal



Insert	Wire gauge	Designation	Order No.
Male	2.5-8mm <sup>2</sup>	HK-006.1/12-M(2.5-8mm <sup>2</sup> )	128 018 011 0001
	6-10mm <sup>2</sup>	HK-006.2/12-M(6-10mm <sup>2</sup> )	128 018 011 0002
Female	2.5-8mm <sup>2</sup>	HK-006.1/12-F(2.5-8mm <sup>2</sup> )	128 018 021 0001
	6-10mm <sup>2</sup>	HK-006.2/12-F(6-10mm <sup>2</sup> )	128 018 021 0002

1) See P00-12~00-13 for the structural characteristics and description of Axial screw terminal.

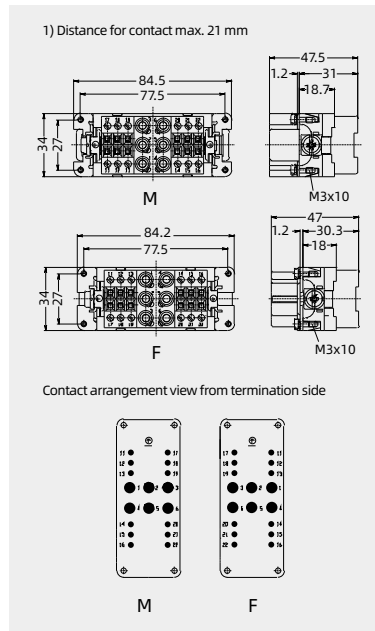

## Accessories

### Tool

hexagonal driver



Description	Designation	Order No.
for axial setscrew with grip	SW-2*100	198 001 003 0002

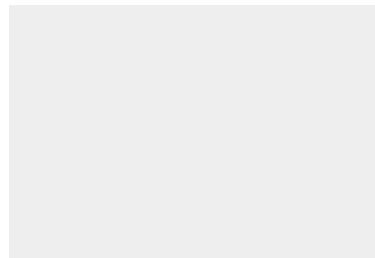

## HK-006/36 Combination inserts



### Technical characteristics

Specifications	DIN EN 60 664 DIN EN 61 984
Approvals	
Inserts	
Number of contacts	6/36+PE
Electrical data acc. to EN 61 984	
Power area	
-Rated current	40A
-Rated voltage	690V
-Rated impulse voltage	8kV
-Pollution degree	3
Signal area	
-Rated current	10A
-Rated voltage	160V
-Rated impulse voltage	2.5kV
-Pollution degree	3
-Pollution degree 2 also	10A 250V 4kV 2
Rated voltage acc. to UL	600/300V
Insulation resistance	$\geq 10^{10}\Omega$
Material	polycarbonate
Limiting temperatures	-40°C ...+125°C
Flammability acc. to UL 94	V0
Mechanical working life(mating cycles)	$\geq 500$
Contacts	
Power contacts	
-Material	copper alloy
-Surface	hard-silver plated hard-gold plated
-Contact resistance	$\leq 1m\Omega$
-Crimp terminal	
- mm <sup>2</sup>	1.5-6mm <sup>2</sup>
- AWG	16-10
-Max. insulation diameter	5mm
Signal contacts	
-Material	copper alloy
-Surface	hard-silver plated hard-gold plated
-Contact resistance	$\leq 3m\Omega$
-Crimp terminal	
- mm <sup>2</sup>	0.14-2.5mm <sup>2</sup>
- AWG	26-14

### Current carrying capacity

The current carrying is limited by maximum temperature of materials for inserts and contacts including terminals

Control and test procedures according to DIN EN 60512-5

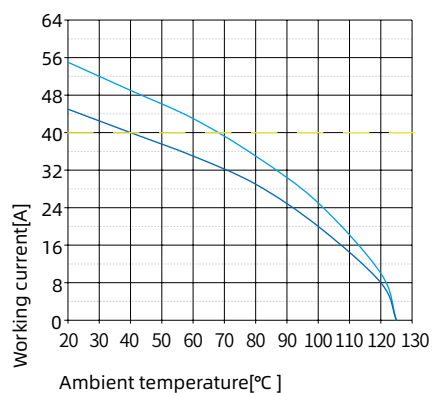

Wire gauge: 10mm<sup>2</sup>  
Wire gauge: 6mm<sup>2</sup>  
Wire gauge: 4mm<sup>2</sup>

# HK-006/36 Combination inserts

690/160V 40/10A 6/36+⊕



## Inserts

Hoods/Housings: size 16B, please find the details on page 15-70~15-1071.

### Crimp terminal

order crimp contacts separately



Insert	Designation	Order No.
Male	HK-006/36-MC	128 042 010 0001
Female	HK-006/36-FC	128 042 020 0001

1) Distance for contact max. 21 mm

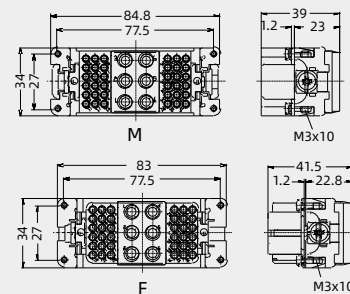

Contact arrangement view from termination side

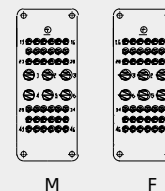

## Crimp contacts

### Crimp contacts 10A

Contact resistance ≤ 3mΩ  
silver plated



gold plated



More crimp contacts 10A  
see P13-02,P13-03.

Male	Order No.	Female	Order No.
CDSM-0.25	101 017 110 0101	CDSF-0.25	101 017 120 0101
CDSM-0.37	101 017 110 0301	CDSF-0.37	101 017 120 0301
CDSM-0.50	101 017 110 0401	CDSF-0.50	101 017 120 0401
CDSM-0.75	101 017 110 0601	CDSF-0.75	101 017 120 0601
CDSM-1.0	101 017 110 0801	CDSF-1.0	101 017 120 0801
CDSM-1.5	101 017 110 0901	CDSF-1.5	101 017 120 0901
CDSM-2.5	101 017 110 1001	CDSF-2.5	101 017 120 1001
CDGM-0.25	101 017 210 0101	CDGF-0.25	101 017 220 0101
CDGM-0.37	101 017 210 0301	CDGF-0.37	101 017 220 0301
CDGM-0.50	101 017 210 0401	CDGF-0.50	101 017 220 0401
CDGM-0.75	101 017 210 0601	CDGF-0.75	101 017 220 0601
CDGM-1.0	101 017 210 0801	CDGF-1.0	101 017 220 0801
CDGM-1.5	101 017 210 0901	CDGF-1.5	101 017 220 0901
CDGM-2.5	101 017 210 1001	CDGF-2.5	101 017 220 1001

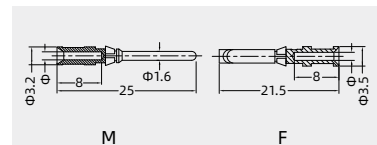

Wire gauge	Φ	Stripping length
0.09-0.25 mm <sup>2</sup>	AWG 28-24	0.65 5 mm
0.14-0.37 mm <sup>2</sup>	AWG 26-22	0.9 8 mm
0.5 mm <sup>2</sup>	AWG 20	1.1 8 mm
0.75 mm <sup>2</sup>	AWG 18	1.3 8 mm
1 mm <sup>2</sup>	AWG 18	1.45 8 mm
1.5 mm <sup>2</sup>	AWG 16	1.75 8 mm
2.5 mm <sup>2</sup>	AWG 14	2.25 6 mm

When the wire gauge is less than 0.75mm<sup>2</sup>, it's better to use the auxiliary pin assembly tool TL15.

### Crimp contacts 40A

silver plated



gold plated



Male	Order No.	Female	Order No.
CCSM-1.5	101 023 110 0901	CCSF-1.5	101 023 120 0901
CCSM-2.5	101 023 110 1001	CCSF-2.5	101 023 120 1001
CCSM-4.0	101 023 110 1201	CCSF-4.0	101 023 120 1201
CCSM-6.0	101 023 110 1301	CCSF-6.0	101 023 120 1301
CCGM-1.5	101 023 210 0901	CCGF-1.5	101 023 220 0901
CCGM-2.5	101 023 210 1001	CCGF-2.5	101 023 220 1001
CCGM-4.0	101 023 210 1201	CCGF-4.0	101 023 220 1201
CCGM-6.0	101 023 210 1301	CCGF-6.0	101 023 220 1301

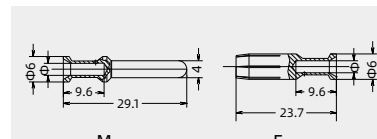

Wire gauge	Φ	Stripping length
1.5 mm <sup>2</sup>	AWG 16	1.75 9.6 mm
2.5mm <sup>2</sup>	AWG 14	2.25 9.6 mm
4 mm <sup>2</sup>	AWG 12	2.85 9.6 mm
6 mm <sup>2</sup>	AWG 10	3.5 9.6 mm

## Tools

### Crimping tool



### Contact removal tool



Wire gauge	Designation	Order No.
0.14-4mm <sup>2</sup>	TL02G	198 001 001 0011
1.5-6mm <sup>2</sup>	TL02-0G	198 001 001 0012

Application	Designation	Order No.
for crimp contacts 10A	TL00	198 001 000 0001

Application	Designation	Order No.
for crimp contacts 40A	TL06G	198 001 000 0009

Notes: The tools for crimp terminal may influence the product quality and stability. Please select the tools recognized by our company.

## HK-012/2 Combination inserts



### Technical characteristics

Specifications	DIN EN 60 664 DIN EN 61 984
Approvals	
Inserts	
Number of contacts	12/2+PE
Electrical data acc. to EN 61 984	
Power area	
-Rated current	40A
-Rated voltage	690V
-Rated impulse voltage	8kV
-Pollution degree	3
Signal area	
-Rated current	10A
-Rated voltage	250V
-Rated impulse voltage	4kV
-Pollution degree	3
Rated voltage acc. to UL	600/300V
Insulation resistance	$\geq 10^{10}\Omega$
Material	polycarbonate
Limiting temperatures	-40°C ...+125°C
Flammability acc. to UL 94	V0
Mechanical working life(mating cycles)	$\geq 500$
Contacts	
Power contacts	
-Material	copper alloy
-Surface	hard-silver plated hard-gold plated
-Contact resistance	$\leq 1\text{m}\Omega$
-Crimp terminal	
- mm <sup>2</sup>	1.5-6mm <sup>2</sup>
- AWG	16-10
Signal contacts	
-Material	copper alloy
-Surface	hard-silver plated hard-gold plated
-Contact resistance	$\leq 3\text{m}\Omega$
-Crimp terminal	
- mm <sup>2</sup>	0.14-2.5mm <sup>2</sup>
- AWG	26-14

### Current carrying capacity

The current carrying is limited by maximum temperature of materials for inserts and contacts including terminals

Control and test procedures according to DIN EN 60512-5

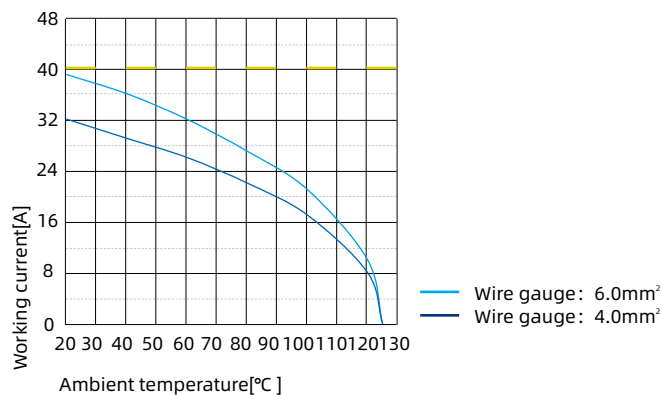

# HK-012/2 Combination inserts

690/250V 40/10A 12/2+⊕



## Inserts

Hoods/Housings: size 16B, please find the details on page 15-70~15-1071.

### Crimp terminal

order crimp contacts separately



Insert	Designation	Order No.
Male	HK-012/2-MC	128 014 010 0001
Female	HK-012/2-FC	128 014 020 0001

1) Distance for contact max. 21 mm

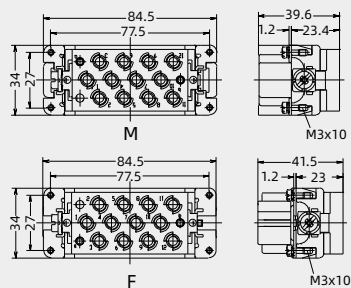

Contact arrangement view from termination side

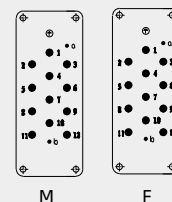

## Crimp contacts

### Crimp contacts 10A

Contact resistance ≤ 3mΩ  
silver plated



gold plated



More crimp contacts 10A  
see P13-02,P13-03.

Male	Order No.	Female	Order No.
CDSM-0.25	101 017 110 0101	CDSF-0.25	101 017 120 0101
CDSM-0.37	101 017 110 0301	CDSF-0.37	101 017 120 0301
CDSM-0.50	101 017 110 0401	CDSF-0.50	101 017 120 0401
CDSM-0.75	101 017 110 0601	CDSF-0.75	101 017 120 0601
CDSM-1.0	101 017 110 0801	CDSF-1.0	101 017 120 0801
CDSM-1.5	101 017 110 0901	CDSF-1.5	101 017 120 0901
CDSM-2.5	101 017 110 1001	CDSF-2.5	101 017 120 1001
CDGM-0.25	101 017 210 0101	CDGF-0.25	101 017 220 0101
CDGM-0.37	101 017 210 0301	CDGF-0.37	101 017 220 0301
CDGM-0.50	101 017 210 0401	CDGF-0.50	101 017 220 0401
CDGM-0.75	101 017 210 0601	CDGF-0.75	101 017 220 0601
CDGM-1.0	101 017 210 0801	CDGF-1.0	101 017 220 0801
CDGM-1.5	101 017 210 0901	CDGF-1.5	101 017 220 0901
CDGM-2.5	101 017 210 1001	CDGF-2.5	101 017 220 1001

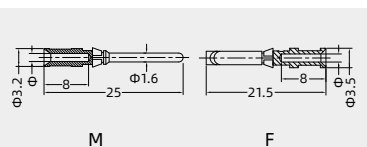

Wire gauge	Φ	Stripping length	
0.09-0.25 mm <sup>2</sup>	AWG 28-24	0.65	5 mm
0.14-0.37 mm <sup>2</sup>	AWG 26-22	0.9	8 mm
0.5 mm <sup>2</sup>	AWG 20	1.1	8 mm
0.75 mm <sup>2</sup>	AWG 18	1.3	8 mm
1 mm <sup>2</sup>	AWG 18	1.45	8 mm
1.5 mm <sup>2</sup>	AWG 16	1.75	8 mm
2.5 mm <sup>2</sup>	AWG 14	2.25	6 mm

When the wire gauge is less than 0.75mm<sup>2</sup>, it's better to use the auxiliary pin assembly tool TL15.

### Crimp contacts 40A

silver plated



gold plated



Male	Order No.	Female	Order No.
CCSM-1.5	101 023 110 0901	CCSF-1.5	101 023 120 0901
CCSM-2.5	101 023 110 1001	CCSF-2.5	101 023 120 1001
CCSM-4.0	101 023 110 1201	CCSF-4.0	101 023 120 1201
CCSM-6.0	101 023 110 1301	CCSF-6.0	101 023 120 1301
CCGM-1.5	101 023 210 0901	CCGF-1.5	101 023 220 0901
CCGM-2.5	101 023 210 1001	CCGF-2.5	101 023 220 1001
CCGM-4.0	101 023 210 1201	CCGF-4.0	101 023 220 1201
CCGM-6.0	101 023 210 1301	CCGF-6.0	101 023 220 1301

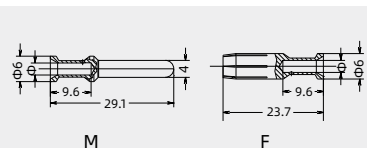

Wire gauge	Φ	Stripping length	
1.5 mm <sup>2</sup>	AWG 16	1.75	9.6 mm
2.5mm <sup>2</sup>	AWG 14	2.25	9.6 mm
4 mm <sup>2</sup>	AWG 12	2.85	9.6 mm
6 mm <sup>2</sup>	AWG 10	3.5	9.6 mm

## Tools

### Crimping tool



### Contact removal tool



Wire gauge	Designation	Order No.
0.14-4mm <sup>2</sup>	TL02G	198 001 001 0011
1.5-6mm <sup>2</sup>	TL02-0G	198 001 001 0012
Application	Designation	Order No.
for crimp contacts 10A	TL00	198 001 000 0001
Application	Designation	Order No.
for crimp contacts 40A	TL06G	198 001 000 0009

Notes: The tools for crimp terminal may influence the product quality and stability. Please select the tools recognized by our company.

## HKH-012/0 Combination high mating cycle inserts



### Technical characteristics

Specifications	DIN EN 60 664 DIN EN 61 984
Approvals	CE ENEC
Inserts	
Number of contacts	12/0+PE
Electrical data acc. to EN 61 984	
Power area	
-Rated current	40A
-Rated voltage	690V
-Rated impulse voltage	8kV
-Pollution degree	3
Rated voltage acc. to UL	600/300V
Insulation resistance	$\geq 10^{10}\Omega$
Material	polycarbonate
Limiting temperatures	-40°C ...+125°C
Flammability acc. to UL 94	V0
Mechanical working life(mating cycles) $\geq 5000$	
Contacts	
Power contacts	
-Material	copper alloy
-Surface	hard-gold plated
-Contact resistance	$\leq 1m\Omega$
-Crimp terminal	
-mm <sup>2</sup>	1.5-6mm <sup>2</sup>
-AWG	16-10

### Current carrying capacity

The current carrying is limited by maximum temperature of materials for inserts and contacts including terminals

Control and test procedures according to DIN EN 60512-5

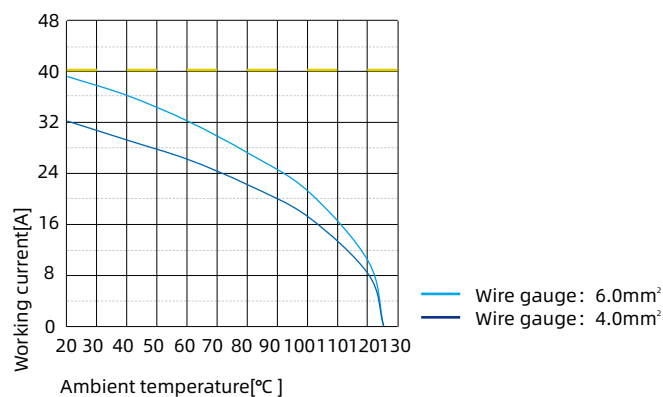



# HKH-012/0 Combination high mating cycle inserts

690V 40A 12/0+ 

CE 

## Inserts

Hoods/Housings: size **16B**, please find the details on page 15-70~15-1071.

### Crimp terminal

order crimp contacts separately



Insert	Designation	Order No.
Male	HKH-012/0-MC	128 012 010 0001
Female	HKH-012/0-FC	128 012 020 0001

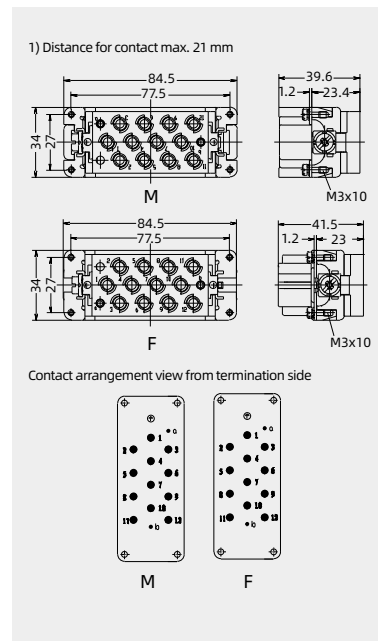

## Crimp contacts

### Crimp contacts 40A-high mating cycle

gold plated

Mechanical working life  
(mating cycles)  $\geq 5000$



Male	Order No.	Female	Order No.
CCGMH-1.5	101 023 210 0909	CCGFH-1.5G	101 023 220 0909
CCGMH-2.5	101 023 210 1009	CCGFH-2.5G	101 023 220 1009
CCGMH-4.0	101 023 210 1209	CCGFH-4.0G	101 023 220 1209
CCGMH-6.0	101 023 210 1309	CCGFH-6.0G	101 023 220 1309
CCGMH-10.0	101 023 210 1409	CCGFH-10.0G	101 023 220 1409

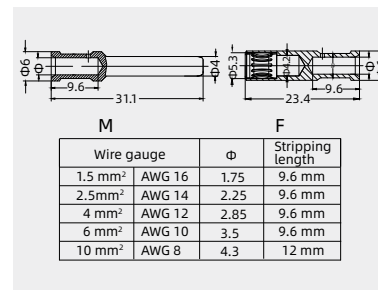

### Tools

Crimping tool



Contact removal tool



Wire gauge	Designation	Order No.
1.5-6mm <sup>2</sup>	TL02-0G	198 001 001 0012
4/6/10mm <sup>2</sup>	TL02-3G	198 001 001 0013

Application	Designation	Order No.
40A 冷压针	TL06G	198 001 000 0009

Notes: The tools for crimp terminal may influence the product quality and stability.  
Please select the tools recognized by our company.

## HK-006/6 Combination inserts



### Technical characteristics

Specifications	DIN EN 60 664 DIN EN 61 984
Approvals	VDE CE ENEC
Inserts	
Number of contacts	6/6+PE
Electrical data acc. to EN 61 984	
Power area	
-Rated current	100A
-Rated voltage	690V
-Rated impulse voltage	8kV
-Pollution degree	3
-Pollution degree 2 also	100A 1000V 8kV 2
Signal area	
-Rated current	16A
-Rated voltage	400V
-Rated impulse voltage	6kV
-Pollution degree	3
Rated voltage acc. to UL	600/300V
Insulation resistance	$\geq 10^{10}\Omega$
Material	polycarbonate
Limiting temperatures	-40°C ... +125°C
Flammability acc. to UL 94	V0
Mechanical working life(mating cycles)	$\geq 500$
Contacts	
Power contacts	
-Material	copper alloy
-Surface	hard-silver plated
-Contact resistance	$\leq 0.5m\Omega$
-Axial screw termination	
- geometric wire gauge	16-35mm <sup>2</sup>
- AWG	5-2
-Max. insulation diameter	11.4mm
-Tightening torque	
-mm <sup>2</sup>	16 25 35
-Nm	6 7 8
-Stripping length	13 <sup>±1</sup> mm
Signal contacts	
-Material	copper alloy
-Surface	hard-silver plated
-Contact resistance	$\leq 3m\Omega$
-Screw terminal	
- geometric wire gauge	0.2-2.5mm <sup>2</sup>
- AWG	24-13
-Tightening torque	0.8Nm
-Stripping length	7.5mm

### Current carrying capacity

The current carrying is limited by maximum temperature of materials for inserts and contacts including terminals

Control and test procedures according to DIN EN 60512-5

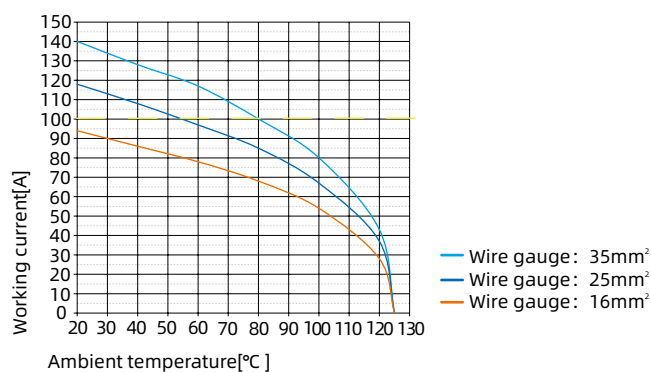

## HK-006/6 Combination inserts

690/400V 100/16A 6/6+

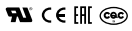

Hoods/Housings: Only suitable for size **24B** high structure shells, please find the details on page 15-108~15-135.  
Not suitable for high structure shells with side entry and without sleeve.

### Inserts

Axial screw terminal<sup>1)</sup>/Screw terminal



Insert	Designation	Order No.
Male	HK-006/6-M	128 012 011 0101
Female	HK-006/6-F	128 012 021 0101

1) See P00-12-00-13 for the structural characteristics and description of Axial screw terminal.

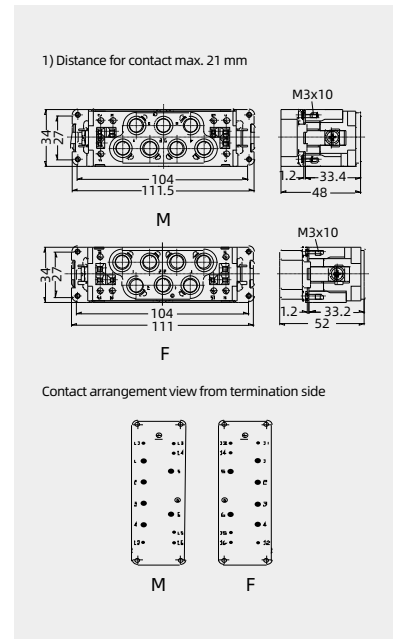

### Accessories

Tool

hexagonal driver



Description	Designation	Order No.
for axial setscrew with grip	SW-4*150	198 001 003 0001

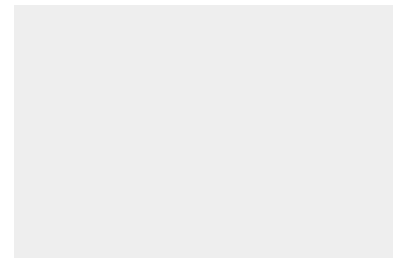

## HK-008/0 Combination inserts



### Technical characteristics

Specifications	DIN EN 60 664 DIN EN 61 984
Approvals	
Inserts	
Number of contacts	8/0+PE
Electrical data acc. to EN 61 984	
Power area	
Rated current	100A
Rated voltage	690V
Rated impulse voltage	8kV
Pollution degree	3
Pollution degree 2 also	100A 1000V 8kV 2
Rated voltage acc. to UL	600V
Rated current acc. to UL	82A
Insulation resistance	$\geq 10^{10}\Omega$
Material	polycarbonate
Limiting temperatures	-40°C ...+125°C
Flammability acc. to UL 94	V0
Mechanical working life(mating cycles)	$\geq 500$
Contacts	
Material	copper alloy
Surface	hard-silver plated
Contact resistance	$\leq 0.5m\Omega$
Axial screw termination	
- geometric wire gauge	10-25mm <sup>2</sup>
- AWG	7-3
Max. insulation diameter	11.4mm
Tightening torque	
-mm <sup>2</sup>	10 16 25
-Nm	6 6 7
Stripping length	13 <sup>±1</sup> mm

### Current carrying capacity

The current carrying is limited by maximum temperature of materials for inserts and contacts including terminals

Control and test procedures according to DIN EN 60512-5

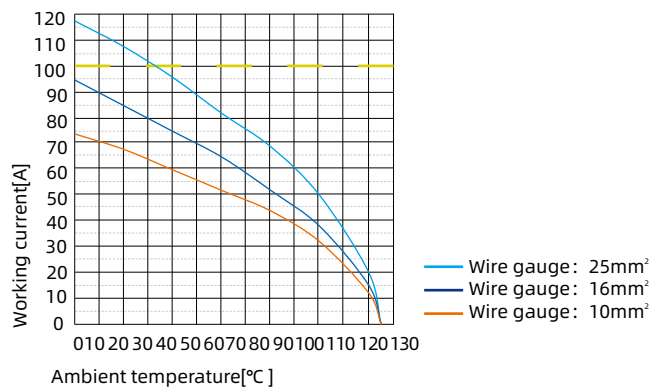

# HK-008/0 Combination inserts

690V 100A 8/0+ 



Hoods/Housings: size 24B, please find the details on page 15-108~15-135.  
Not suitable for high structure shells with side entry and without sleeve.

## Inserts

Axial screw terminal<sup>1)</sup>/Screw terminal



Insert	Designation	Order No.
Male	HK-008/0-M	128 008 011 0001
Female	HK-008/0-F	128 008 021 0001

1) See P00-12~00-13 for the structural characteristics and description of Axial screw terminal.

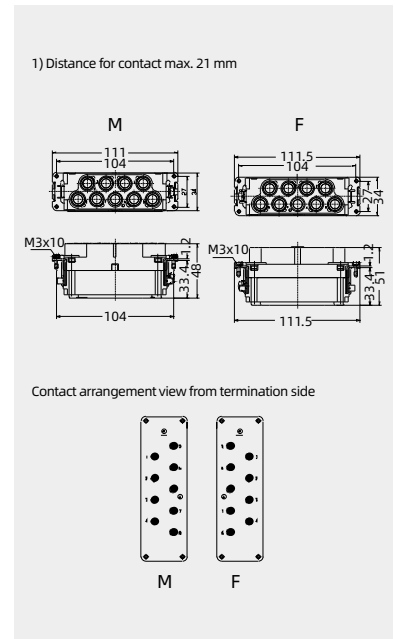

## Accessories

Tool

hexagonal driver



Description	Designation	Order No.
for axial setscrew with grip	SW-4*150	198 001 003 0001

## HK-009/9/18 Combination inserts



### Technical characteristics

Specifications	DIN EN 60 664 DIN EN 61 984
Approvals	
Inserts	
Number of contacts	9/9/18
Electrical data acc. to EN 61 984	
Rated current	40A/16A/10A
Rated voltage	830V/830V/250V
Rated impulse voltage	8kV/8kV/4kV
Pollution degree	3
Insulation resistance	$\geq 10^{10}\Omega$
Material	polycarbonate
Limiting temperatures	-40°C ...+125°C
Flammability acc. to UL 94	V0
Mechanical working life(mating cycles)	$\geq 500$
Contacts	
Material	copper alloy
Surface	hard-silver plated
	hard-gold plated
Contact resistance	$\leq 3m\Omega$
Crimp terminal	
-mm <sup>2</sup>	1.5-6mm <sup>2</sup> / 0.14-4mm <sup>2</sup> / 0.14-2.5mm <sup>2</sup>
-AWG	16-10 / 26-12 / 26-14
Stripping length	9.5/7.5/8 (6)mm

830V/830V/250V 40A/16A/10A 9/9/18+



Inserts

Hoods/Housings: size 16B, please find the details on page 15-70~15-1071.

Crimp terminal

order crimp contacts separately

Insert	Designation	Order No.
Male	HK-009/9/18-MC	128 036 010 0001
Female	HK-009/9/18-FC	128 036 020 0001



To ensure that the grounding pin comes into contact first during the insertion process, it is necessary to use a guide pin/guide hole in conjunction with 1980020050017 and 1980020050031 → P14-17

Crimp contacts 10A

Contact resistance ≤ 3mΩ  
silver plated



gold plated



More crimp contacts 10A  
see P13-02,P13-03.

Crimp contacts 16A

Contact resistance ≤ 1mΩ  
silver plated



gold plated



More crimp contacts 16A  
see P13-04.

Crimp contacts 40A

silver plated



gold plated



Tools

Crimping tool



Wire gauge	Designation	Order No.
0.14-4mm <sup>2</sup>	TL02G	198 001 001 0011
1.5-6mm <sup>2</sup>	TL02-OG	198 001 001 0012

Tools

Contact removal tool



Application	Designation	Order No.
for 10A crimp contact	TL00	198 001 000 0001
for 16A crimp contact	TL01	198 001 000 0002
for 40A crimp contact	TL06G	198 001 000 0009

Notes: The tools for crimp terminal may influence the product quality and stability. Please select the tools recognized by our company. More tools detail please find the page32-03~32-06.

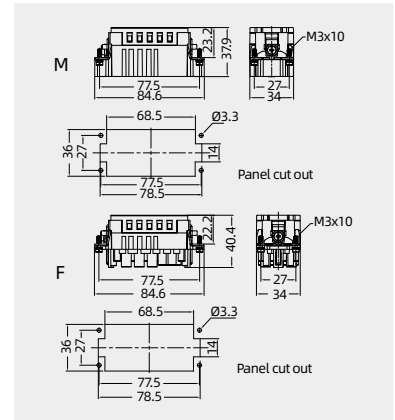

Wire gauge	Φ	Stripping length
0.09-0.25 mm <sup>2</sup> AWG 28-24	0.65	5 mm
0.14-0.37 mm <sup>2</sup> AWG 26-22	0.9	8 mm
0.5 mm <sup>2</sup> AWG 20	1.1	8 mm
0.75 mm <sup>2</sup> AWG 18	1.3	8 mm
1 mm <sup>2</sup> AWG 18	1.45	8 mm
1.5 mm <sup>2</sup> AWG 16	1.75	8 mm
2.5 mm <sup>2</sup> AWG 14	2.25	6 mm

When the wire gauge is less than 0.75mm<sup>2</sup>, it's better to use the auxiliary pin assembly tool TL15.

Identification	Wire gauge	Stripping length
no groove	0.14-0.37 mm <sup>2</sup> AWG 26-22	7.5mm
no groove	0.5 mm <sup>2</sup> AWG 20	7.5mm
1 groove	0.75 mm <sup>2</sup> AWG 18	7.5mm
1 groove	1 mm <sup>2</sup> AWG 18	7.5mm
2 grooves	1.5 mm <sup>2</sup> AWG 16	7.5mm
3 grooves	2.5 mm <sup>2</sup> AWG 14	7.5mm
wide groove	3 mm <sup>2</sup> AWG 12	7.5mm
no groove	4 mm <sup>2</sup> AWG 12	7.5mm

When the wire gauge is less than 0.75mm<sup>2</sup>, it's better to use the auxiliary pin assembly tool TL15.

Wire gauge	Φ	Stripping length
1.5 mm <sup>2</sup> AWG 16	1.75	9.6 mm
2.5mm <sup>2</sup> AWG 14	2.25	9.6 mm
4 mm <sup>2</sup> AWG 12	2.85	9.6 mm
6 mm <sup>2</sup> AWG 10	3.5	9.6 mm

## HK-032/55 Combination inserts



### Technical characteristics

Specifications	DIN EN 60 664 DIN EN 61 984
Approvals	
Inserts	
Number of contacts	32/55
Electrical data acc. to EN 61 984	
Signal area	
Rated current	4A
Rated voltage	50V
Rated impulse voltage	0.8kV
Pollution degree	2
Power area	
Rated current	10A
Rated voltage	250V
Rated impulse voltage	4kV
Pollution degree	2
Rated voltage acc. to UL	600V
Insulation resistance	$\geq 10^{10}\Omega$
Material	polycarbonate
Limiting temperatures	-40°C ...+125°C
Flammability acc. to UL 94	V0
Mechanical working life(mating cycles)	$\geq 500$
Contacts	
Material	copper alloy
Surface	hard-silver plated hard-gold plated
Contact resistance	$\leq 3m\Omega$
Crimp terminal	
-mm <sup>2</sup>	0.09-0.52mm <sup>2</sup> /0.14-2.5mm <sup>2</sup>
-AWG	28-20/26-14
Stripping length	5/8mm



HK-032/55 Combination inserts

250/50V 10/4A 32/55+ ⚡



Inserts

Hoods/Housings: size 10B, please find the details on page 15-39~15-69.

Crimp terminal

order crimp contacts separately



Insert	Designation	Order No.
Male	HK-032/55-MC	128 087 010 0001
Female	HK-032/55-FC	128 087 020 0001

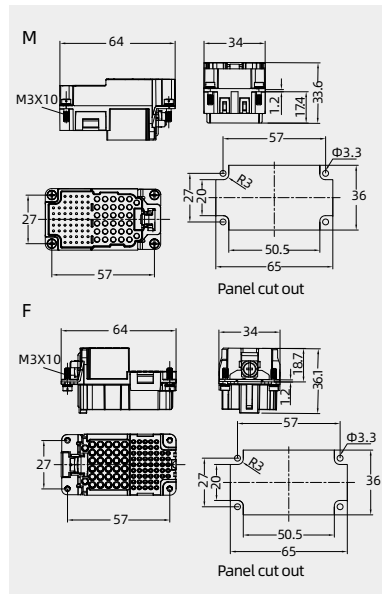

Crimp contacts

Crimp contacts 5A

Contact resistance ≤ 3mΩ  
silver plated



gold plated



Male	Order No.	Female	Order No.
CSSM-0.25	101 014 110 0101	CSSF-0.25	101 014 120 0101
CSSM-0.33	101 014 110 0201	CSSF-0.33	101 014 120 0201
CSSM-0.52	101 014 110 0501	CSSF-0.52	101 014 120 0501
CSGM-0.25	101 014 210 0101	CSGF-0.25	101 014 220 0101
CSGM-0.33	101 014 210 0201	CSGF-0.33	101 014 220 0201
CSGM-0.52	101 014 210 0501	CSGF-0.52	101 014 220 0501

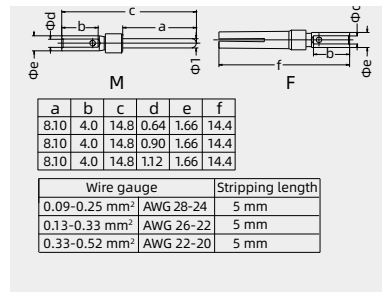

Stamped contacts 5A

Contact resistance ≤ 10mΩ

silver plated



gold plated



coil stock



Male	Order No.	Female	Order No.
CSSM-0.82P	101 014 110 0750	CSSF-0.82P	101 014 120 0750
CSGM-0.82P	101 014 210 0750	CSGF-0.82P	101 014 220 0750

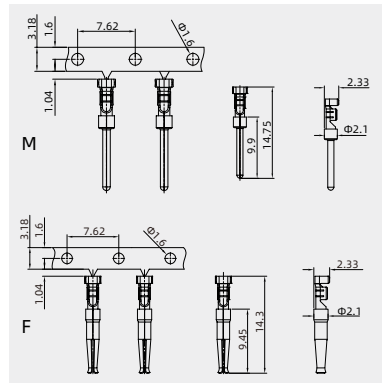

Note: 10kpcs/volume

Notes: The tools for crimp terminal may influence the product quality and stability. Please select the tools recognized by our company.

# HK-032/55 Combination inserts

## Crimp contacts 10A

Contact resistance  $\leq 3m\Omega$   
silver plated



gold plated



More crimp contacts 10A  
see P13-02,P13-03.

Male	Order No.	Female	Order No.
CDSM-0.25	101 017 110 0101	CDSF-0.25	101 017 120 0101
CDSM-0.37	101 017 110 0301	CDSF-0.37	101 017 120 0301
CDSM-0.50	101 017 110 0401	CDSF-0.50	101 017 120 0401
CDSM-0.75	101 017 110 0601	CDSF-0.75	101 017 120 0601
CDSM-1.0	101 017 110 0801	CDSF-1.0	101 017 120 0801
CDSM-1.5	101 017 110 0901	CDSF-1.5	101 017 120 0901
CDSM-2.5	101 017 110 1001	CDSF-2.5	101 017 120 1001
CDGM-0.25	101 017 210 0101	CDGF-0.25	101 017 220 0101
CDGM-0.37	101 017 210 0301	CDGF-0.37	101 017 220 0301
CDGM-0.50	101 017 210 0401	CDGF-0.50	101 017 220 0401
CDGM-0.75	101 017 210 0601	CDGF-0.75	101 017 220 0601
CDGM-1.0	101 017 210 0801	CDGF-1.0	101 017 220 0801
CDGM-1.5	101 017 210 0901	CDGF-1.5	101 017 220 0901
CDGM-2.5	101 017 210 1001	CDGF-2.5	101 017 220 1001

Wire gauge	$\phi$	Stripping length
0.09-0.25 mm <sup>2</sup>	AWG 28-24	0.65
0.14-0.37 mm <sup>2</sup>	AWG 26-22	0.9
0.5 mm <sup>2</sup>	AWG 20	1.1
0.75 mm <sup>2</sup>	AWG 18	1.3
1 mm <sup>2</sup>	AWG 18	1.45
1.5 mm <sup>2</sup>	AWG 16	1.75
2.5 mm <sup>2</sup>	AWG 14	2.25

When the wire gauge is less than 0.75mm<sup>2</sup>, it's better to use the auxiliary pin assembly tool TL15.

### Tools

Crimping tool	Wire gauge	Designation	Order No.
	0.09-0.82mm <sup>2</sup>	TL03	198 001 001 0002
Contact removal tool	Application	Designation	Order No.
	for 5A crimp contact	TL08	198 001 000 0006

### Tools

Crimping tool	Wire gauge	Designation	Order No.
	0.14-4mm <sup>2</sup>	TL02G	198 001 001 0011
Contact removal tool	Application	Designation	Order No.
	for 10A crimp contact	TL00	198 001 000 0001

Notes: The tools for crimp terminal may influence the product quality and stability. Please select the tools recognized by our company. More tools detail please find the page32-03--32-06.

## HK-009/12/25 Combination inserts



### Technical characteristics

Specifications	DIN EN 60 664 DIN EN 61 984
Approvals	<b>UL</b> <b>UL</b>
Inserts	
Number of contacts	9/12/25
Electrical data acc. to EN 61 984	
Signal area	
Rated current	5A
Rated voltage	50V
Rated impulse voltage	0.8kV
Pollution degree	3
Power area	
Rated current	10A/40A
Rated voltage	250V/630V
Rated impulse voltage	4kV/8kV
Pollution degree	3
Insulation resistance	$\geq 10^{10}\Omega$
Material	polycarbonate
Limiting temperatures	-40°C ...+125°C
Flammability acc. to UL 94	V0
Mechanical working life(mating cycles)	$\geq 500$
Contacts	
Material	copper alloy
Surface	hard-silver plated hard-gold plated
Contact resistance	$\leq 3m\Omega/1m\Omega$
Crimp terminal	
-mm <sup>2</sup>	0.09-0.52mm <sup>2</sup> /0.14-2.5mm <sup>2</sup> / 1.5-6mm <sup>2</sup>
-AWG	28-20/26-14/16-10
Stripping length	5/8/9(9.6)mm

## HK-009/12/25 Combination inserts

630/250/50V 40/10/5A 009/12/25+ 



### Inserts

Hoods/Housings: size 16B, please find the details on page 15-70~15-1071.

#### Crimp terminal

order crimp contacts separately



Insert	Designation	Order No.
Male	HK-009/12/25-MC	128 009 010 0002
Female	HK-009/12/25-FC	128 009 020 0002

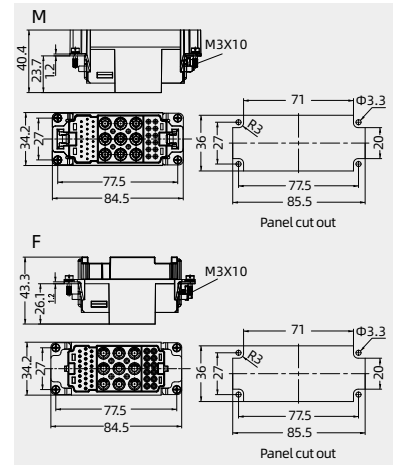

### Crimp contacts

#### Crimp contacts 5A

Contact resistance ≤ 3mΩ  
silver plated



gold plated



Male	Order No.	Female	Order No.
CSSM-0.25	101 014 110 0101	CSSF-0.25	101 014 120 0101
CSSM-0.33	101 014 110 0201	CSSF-0.33	101 014 120 0201
CSSM-0.52	101 014 110 0501	CSSF-0.52	101 014 120 0501
CSGM-0.25	101 014 210 0101	CSGF-0.25	101 014 220 0101
CSGM-0.33	101 014 210 0201	CSGF-0.33	101 014 220 0201
CSGM-0.52	101 014 210 0501	CSGF-0.52	101 014 220 0501

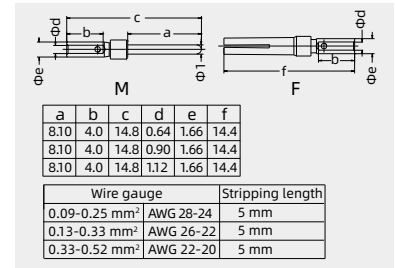

#### Stamped contacts 5A

Contact resistance ≤ 10mΩ  
silver plated



gold plated



coil stock



Note: 10kpcs/volume

Male	Order No.	Female	Order No.
CSSM-0.82P	101 014 110 0750	CSSF-0.82P	101 014 120 0750
CSGM-0.82P	101 014 210 0750	CSGF-0.82P	101 014 220 0750

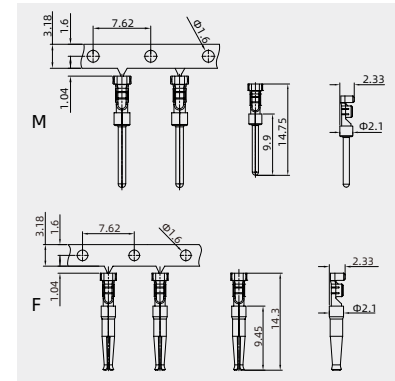

#### Crimp contacts 10A

Contact resistance ≤ 3mΩ  
silver plated



gold plated



Male	Order No.	Female	Order No.
CDSM-0.25	101 017 110 0101	CDSF-0.25	101 017 120 0101
CDSM-0.37	101 017 110 0301	CDSF-0.37	101 017 120 0301
CDSM-0.50	101 017 110 0401	CDSF-0.50	101 017 120 0401
CDSM-0.75	101 017 110 0601	CDSF-0.75	101 017 120 0601
CDSM-1.0	101 017 110 0801	CDSF-1.0	101 017 120 0801
CDSM-1.5	101 017 110 0901	CDSF-1.5	101 017 120 0901
CDSM-2.5	101 017 110 1001	CDSF-2.5	101 017 120 1001
CDGM-0.25	101 017 210 0101	CDGF-0.25	101 017 220 0101
CDGM-0.37	101 017 210 0301	CDGF-0.37	101 017 220 0301
CDGM-0.50	101 017 210 0401	CDGF-0.50	101 017 220 0401
CDGM-0.75	101 017 210 0601	CDGF-0.75	101 017 220 0601
CDGM-1.0	101 017 210 0801	CDGF-1.0	101 017 220 0801
CDGM-1.5	101 017 210 0901	CDGF-1.5	101 017 220 0901
CDGM-2.5	101 017 210 1001	CDGF-2.5	101 017 220 1001

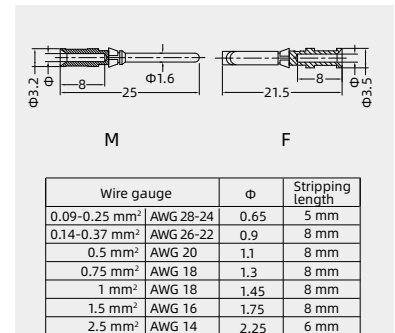

More crimp contacts 10A  
see P13-02, P13-03.

When the wire gauge is less than 0.75mm<sup>2</sup>, it's better to use the auxiliary pin assembly tool TL15.

Notes: The tools for crimp terminal may influence the product quality and stability.

## Crimp contacts

### Crimp contacts 40A

silver plated



gold plated



Male	Order No.	Female	Order No.
CCSM-1.5	101 023 110 0901	CCSF-1.5	101 023 120 0901
CCSM-2.5	101 023 110 1001	CCSF-2.5	101 023 120 1001
CCSM-4.0	101 023 110 1201	CCSF-4.0	101 023 120 1201
CCSM-6.0	101 023 110 1301	CCSF-6.0	101 023 120 1301
CCGM-1.5	101 023 210 0901	CCGF-1.5	101 023 220 0901
CCGM-2.5	101 023 210 1001	CCGF-2.5	101 023 220 1001
CCGM-4.0	101 023 210 1201	CCGF-4.0	101 023 220 1201
CCGM-6.0	101 023 210 1301	CCGF-6.0	101 023 220 1301

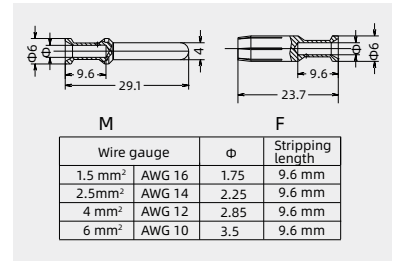

### Tools

Crimping tool



Wire gauge	Designation	Order No.
0.09-0.82mm <sup>2</sup>	TL03	198 001 001 0002
0.14-4mm <sup>2</sup>	TL02G	198 001 001 0011
1.5-6mm <sup>2</sup>	TL02-0G	198 001 001 0012

### Tools

Contact removal tool



Wire gauge	Designation	Order No.
for 5A crimp contact	TL08	198 001 000 0006
for 10A crimp contact	TL00	198 001 000 0001
for 40A crimp contact	TL06G	198 001 000 0009

Notes: The tools for crimp terminal may influence the product quality and stability.  
Please select the tools recognized by our company. More tools detail please find the page32-03~32-06.

## HY-004/RJ45 Combination inserts



### Technical characteristics

Specifications	DIN EN 60 664 DIN EN 61 984
Approvals	
Inserts	
Electrical data acc. to EN 61 984	
Power area	
Number of contacts	4+PE
Rated current	16A
Rated voltage	240V
Rated impulse voltage	4kV
Pollution degree	3
Insulation resistance	$\geq 10^{10}\Omega$
Material	polycarbonate
Color	RAL 7032 (Light grey)
Limiting temperatures	-40°C - +85°C
Signal area	
Number of contacts	8
Rated current	1A
-Rated voltage	50V
-Rated impulse voltage	0.8kV
-Pollution degree	3
Insulation resistance	$\geq 10^{10}\Omega$
Material	polycarbonate
Limiting temperatures	-40°C ...+85°C
Flammability acc. to UL 94	V0
Mechanical working life(mating cycles)	$\geq 500$
Transmission characteristics:	over 6 type jumper up to 500MHz According to ISO/IEC 24 702; ISO/IEC 11 801
Transmission rate:	10/100/1000Mbit/10Gbit/s
Contacts	
Material	copper alloy
Surface	hard-silver plated hard-gold plated
Contact resistance	$\leq 1m\Omega$
Crimp terminal	
-mm <sup>2</sup>	0.37-4mm <sup>2</sup>
-AWG	22-12

# HY-004/RJ45 Combination inserts

240/50V 16/1A 4+ 

## Inserts

Crimp terminal  
order crimp contacts separately



Insert	Designation	Order No.
Male	HY-004/RJ45-MC	138 004 010 0001
Female	HY-004/RJ45-FC	138 004 020 0001

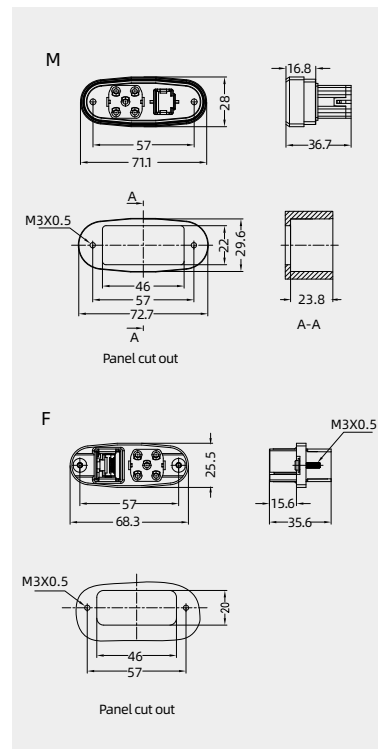

## Crimp contacts

Crimp contacts 16A

Contact resistance  $\leq 1m\Omega$   
silver plated



gold plated



More crimp contacts 16A see P13-04.

Male	Order No.	Female	Order No.
CESM-0.37	101 019 110 0301	CESF-0.37	101 019 120 0301
CESM-0.50	101 019 110 0401	CESF-0.50	101 019 120 0401
CESM-0.75	101 019 110 0601	CESF-0.75	101 019 120 0601
CESM-1.0	101 019 110 0801	CESF-1.0	101 019 120 0801
CESM-1.5	101 019 110 0901	CESF-1.5	101 019 120 0901
CESM-2.5	101 019 110 1001	CESF-2.5	101 019 120 1001
CESM-3.0	101 019 110 1101	CESF-3.0	101 019 120 1101
CESM-4.0	101 019 110 1201	CESF-4.0	101 019 120 1201
CEGM-0.37	101 019 210 0301	CEGF-0.37	101 019 220 0301
CEGM-0.50	101 019 210 0401	CEGF-0.50	101 019 220 0401
CEGM-0.75	101 019 210 0601	CEGF-0.75	101 019 220 0601
CEGM-1.0	101 019 210 0801	CEGF-1.0	101 019 220 0801
CEGM-1.5	101 019 210 0901	CEGF-1.5	101 019 220 0901
CEGM-2.5	101 019 210 1001	CEGF-2.5	101 019 220 1001
CEGM-3.0	101 019 210 1101	CEGF-3.0	101 019 220 1101
CEGM-4.0	101 019 210 1201	CEGF-4.0	101 019 220 1201

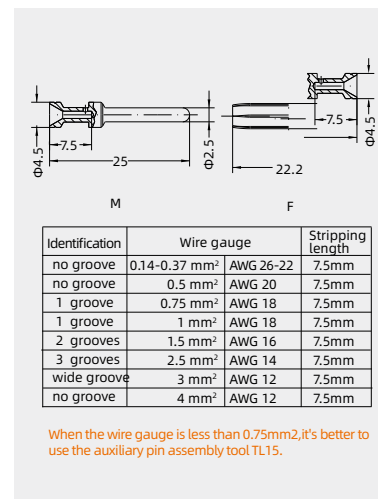

Tools



Wire gauge	Designation	Order No.
0.14-4mm <sup>2</sup>	TL02G	198 001 001 0011
Wire gauge: 0.14-0.37mm <sup>2</sup> please select TL02 Crimping tool.		
Application	Designation	Order No.
for crimp contacts 16A	TL01	198 001 000 0002

More tools detail please find the page 32-03~32-06.

Notes: The tools for crimp terminal may influence the product quality and stability. Please select the tools recognized by our company.

# HE AV SERIES

Extendible connector





# HE AV SERIES Extendible inserts

## Technical characteristics

Specifications	DIN EN 60 664 DIN EN 61 984
Approvals	
Inserts	
Number of contacts	6,10,16,24+PE
Electrical data acc. to EN 61 984	
-Rated current	16A
-Rated voltage	500V
-Rated impulse voltage	6kV
-Pollution degree	3
-Pollution degree 2 also	16A 400/690V 6kV 2
Rated voltage acc. to UL	600V
Insulation resistance	$\geq 10^{10}\Omega$
Material	polycarbonate
Limiting temperatures	-40°C ...+125°C
Flammability acc. to UL 94	V0
Mechanical working life(mating cycles)	$\geq 500$
Contacts	
Material	copper alloy
Surface	hard-silver plated tin plated
Contact resistance	$\leq 4m\Omega$
Screw terminal	
- Wire gauge	0.2-2.5mm <sup>2</sup>
- AWG	24-14
- Tightening/test torque	0.5Nm

## Current carrying capacity

The current carrying is limited by maximum temperature of materials for inserts and contacts including terminals

Control and test procedures according to DIN EN 60512-5

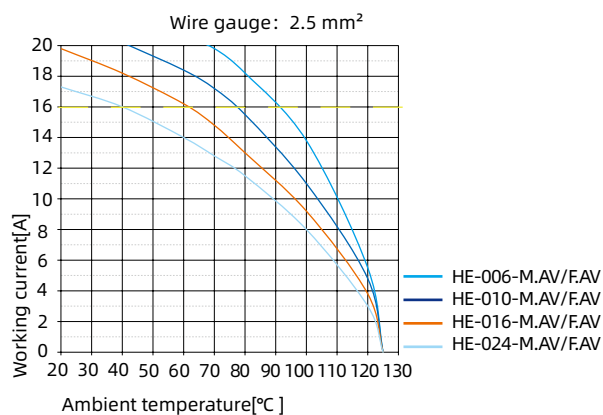
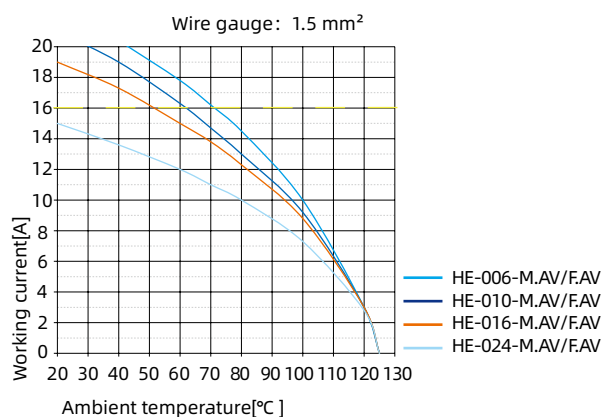

## HE AV Extendible inserts

500V 16A 6+ ⊕

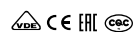

## Inserts

Hoods/Housings: size 6B bulkhead mounted housings.

For the HEAV extendible inserts assembly instructions pls see the 09-13 page

## Male, Screw terminal



Size	Description	Designation	Order No.
6B	left hand version	HE-006-M.AV.L	122 006 011 0101
6B	right hand version	HE-006-M.AV.R	122 006 011 0102

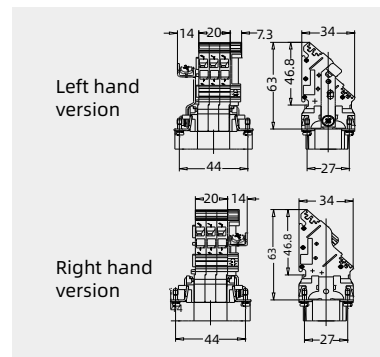

## Female, Screw terminal



Size	Description	Designation	Order No.
6B	left hand version	HE-006-F.AV.L	122 006 021 0101
6B	right hand version	HE-006-F.AV.R	122 006 021 0102

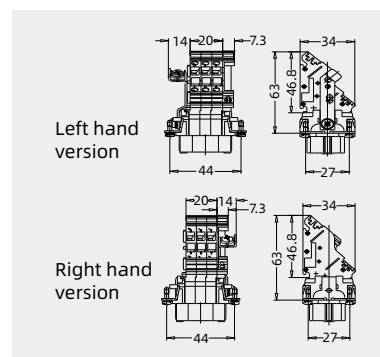

## Male, Quick-in



Size	Description	Designation	Order No.
6B	left hand version	HE-006-MQ.AV.L	122 006 001 0001
6B	right hand version	HE-006-MQ.AV.R	122 006 001 0002

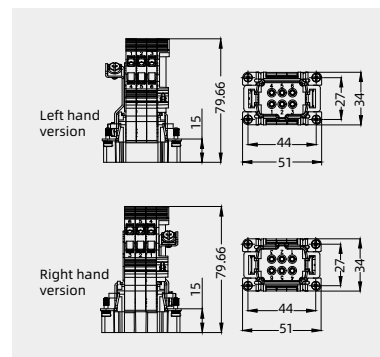



## Female, Quick-in

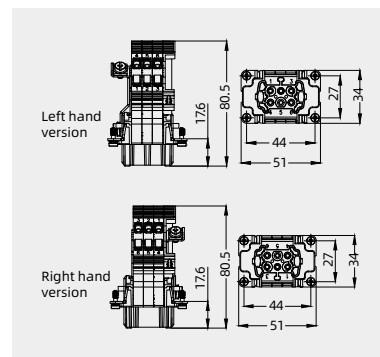

Size	Description	Designation	Order No.
6B	left hand version	HE-006-FQ.AV.L	122 006 002 0001
6B	right hand version	HE-006-FQ.AV.R	122 006 002 0002

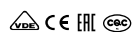

## HE AV Extendible inserts

500V 16A 10+ 

## Inserts

Hoods/Housings: size 10B bulkhead mounted housings.  
For the HEAV extendible inserts assembly instructions pls see the 09-13 page

## Male, Screw terminal



Size	Description	Designation	Order No.
10B	left hand version	HE-010-M.AV.L	122 010 011 0101
10B	right hand version	HE-010-M.AV.R	122 010 011 0102

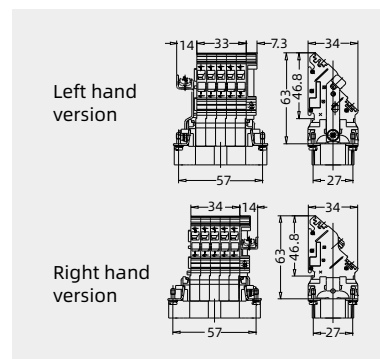

## Female, Screw terminal



Size	Description	Designation	Order No.
10B	left hand version	HE-010-F.AV.L	122 010 021 0101
10B	right hand version	HE-010-F.AV.R	122 010 021 0102

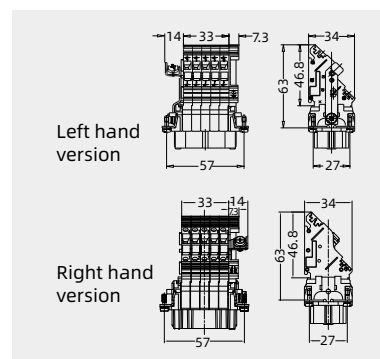

## Male, Quick-in



Size	Description	Designation	Order No.
10B	left hand version	HE-010-MQ.AV.L	122 010 001 0001
10B	right hand version	HE-010-MQ.AV.R	122 010 001 0002

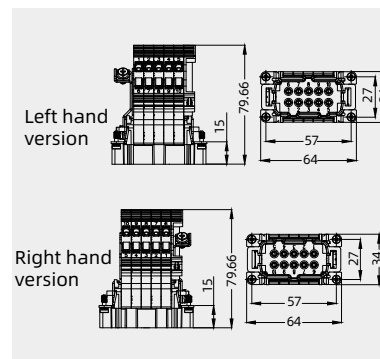

## Female, Quick-in



Size	Description	Designation	Order No.
10B	left hand version	HE-010-FQ.AV.L	122 010 002 0001
10B	right hand version	HE-010-FQ.AV.R	122 010 002 0002

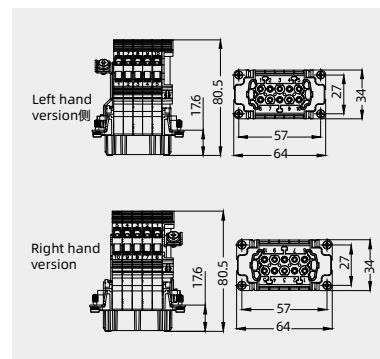

## HE AV Extendible inserts

500V 16A 16+ ⚡



## Inserts

Hoods/Housings: size 16B bulkhead mounted housings.

For the HEAV extendible inserts assembly instructions pls see the 09-13 page

## Male, Screw terminal



Size	Description	Designation	Order No.
16B	left hand version	HE-016-M.AV.L	122 016 011 0101
16B	right hand version	HE-016-M.AV.R	122 016 011 0102

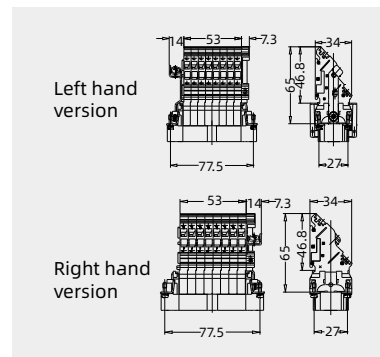

## Female, Screw terminal



Size	Description	Designation	Order No.
16B	left hand version	HE-016-F.AV.L	122 016 021 0101
16B	right hand version	HE-016-F.AV.R	122 016 021 0102

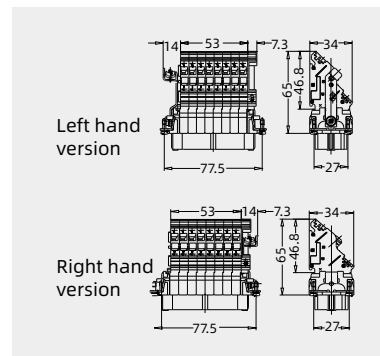

## Male, Quick-in



Size	Description	Designation	Order No.
16B	left hand version	HE-016-MQ.AV.L	122 016 001 0001
16B	right hand version	HE-016-MQ.AV.R	122 016 001 0002

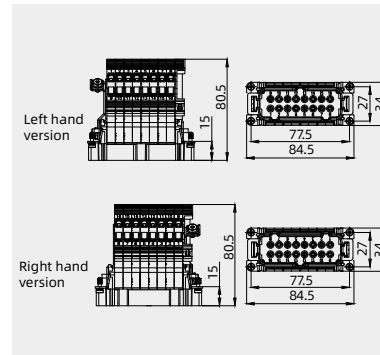



## Female, Quick-in

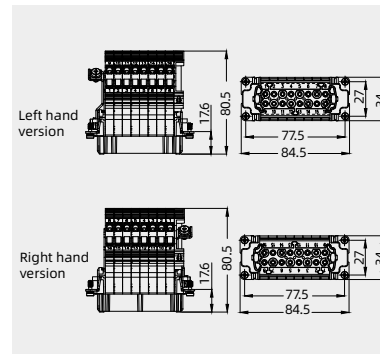

Size	Description	Designation	Order No.
16B	left hand version	HE-016-FQ.AV.L	122 016 002 0001
16B	right hand version	HE-016-FQ.AV.R	122 016 002 0002

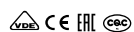

## HE AV Extendible inserts

500V 16A 24+ 

## Inserts

Hoods/Housings: size 24B bulkhead mounted housings.  
For the HEAV extendible inserts assembly instructions pls see the 09-13 page

## Male, Screw terminal

Size	Description	Designation	Order No.
24B	left hand version	HE-024-M.AV.L	122 024 011 0101
24B	right hand version	HE-024-M.AV.R	122 024 011 0102

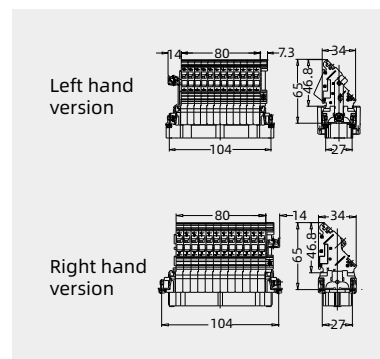

## Female, Screw terminal

Size	Description	Designation	Order No.
24B	left hand version	HE-024-F.AV.L	122 024 021 0101
24B	right hand version	HE-024-F.AV.R	122 024 021 0102

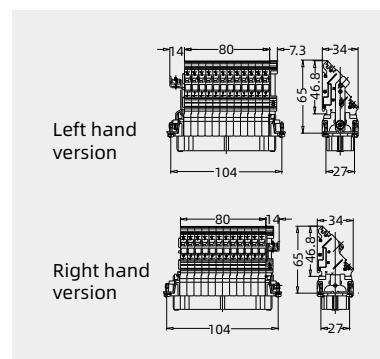

## Male, Quick-in

Size	Description	Designation	Order No.
24B	left hand version	HE-024-MQ.AV.L	122 024 001 0001
24B	right hand version	HE-024-MQ.AV.R	122 024 001 0002

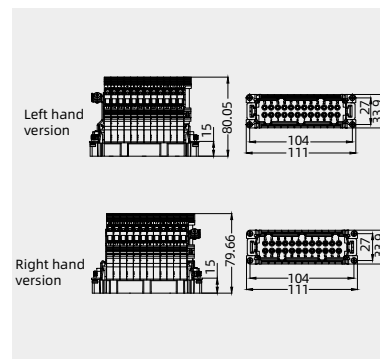

## Female, Quick-in

Size	Description	Designation	Order No.
24B	left hand version	HE-024-FQ.AV.L	122 024 002 0001
24B	right hand version	HE-024-FQ.AV.R	122 024 002 0002

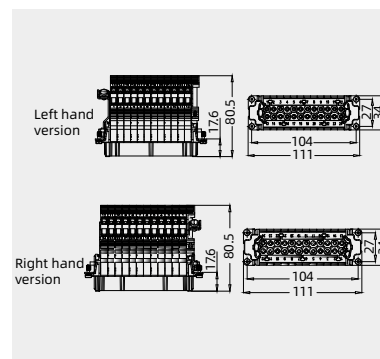

Using the fixing element can secure the HE AV insert inside the switch cabinet on standard rails.

## Fixing element



Description	Designation	Order No.
for terminal block connector	FE-EAV	198 002 003 0022

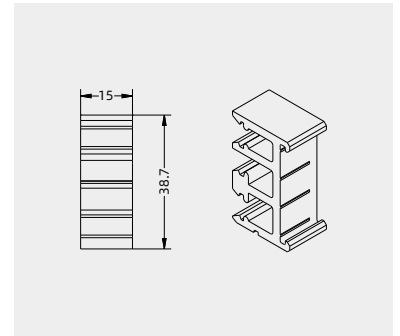

## Examples for Installstion

### Introductions

HE-006 =1pcs  
 HE-010,HE-016,HE-024 =2pcs

# HD AV SERIES

Extendible connector



# HD AV SERIES

## Technical characteristics

Specifications	DIN EN 60 664 DIN EN 61 984
Approvals	ERC
Inserts	
Number of contacts	40,64+PE
Electrical data acc. to EN 61 984	
-Rated current	10A
-Rated voltage	250V
-Rated impulse voltage	4kV
-Pollution degree	3
-Pollution degree 2 also	10A 230/400V 4kV 2
Rated voltage acc. to UL	600V
Insulation resistance	$\geq 10^{10}\Omega$
Material	polycarbonate
Limiting temperatures	-40°C ...+125°C
Flammability acc. to UL 94	V0
Mechanical working life(mating cycles)	$\geq 500$
Contacts	
Material	copper alloy
Surface	
- mating side	hard-silver plated
- termination side	tin plated
Contact resistance	$\leq 10m\Omega$
Screw terminal	
- Wire gauge	0.2-2.5mm <sup>2</sup>
- AWG	24-14
- Tightening/test torque	0.5Nm

## Current carrying capacity

The current carrying is limited by maximum temperature of materials for inserts and contacts including terminals

Control and test procedures according to DIN EN 60512-5

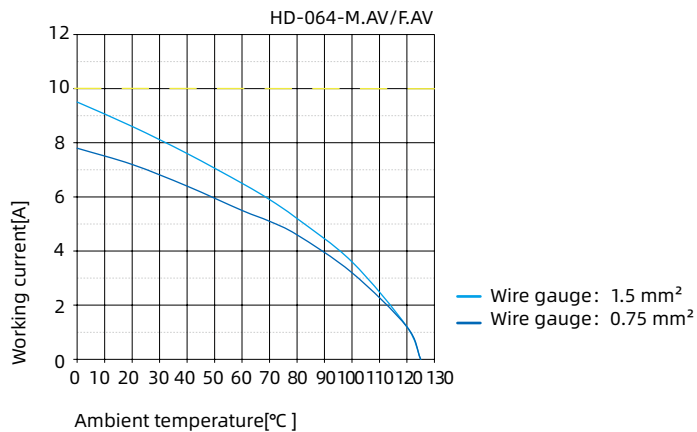
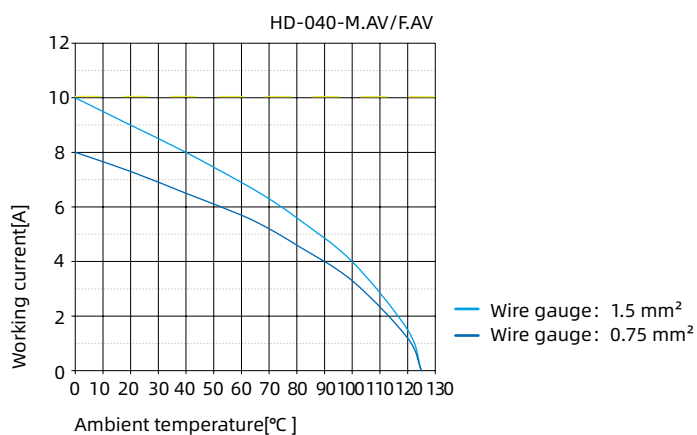



HD AV Extendible inserts

250V 10A 40+ 

EH

Inserts

Hoods/Housings: size 16B bulkhead mounted housings.  
For the HDAV extendible inserts assembly instructions pls see the 09-13 page

Male, Screw terminal



Size	Description	Designation	Order No.
16B	left hand version	HD-040-M.AV.L	125 040 011 0101
16B	right hand version	HD-040-M.AV.R	125 040 011 0102

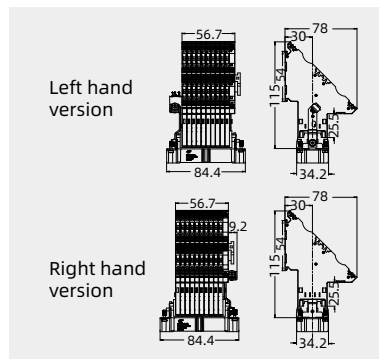

Female, Screw terminal



Size	Description	Designation	Order No.
16B	left hand version	HD-040-F.AV.L	125 040 021 0101
16B	right hand version	HD-040-F.AV.R	125 040 021 0102

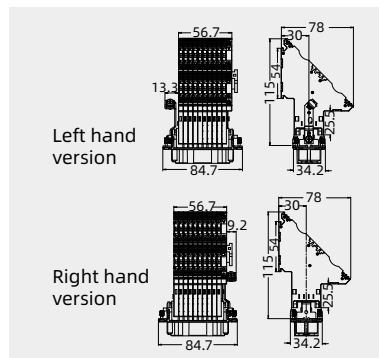

HD AV Extendible inserts

250V 10A 64+ 

EH

Inserts

Hoods/Housings: size 24B bulkhead mounted housings.  
For the HDAV extendible inserts assembly instructions pls see the 09-13 page

Male, Screw terminal



Size	Description	Designation	Order No.
24B	left hand version	HD-064-M.AV.L	125 064 011 0101
24B	right hand version	HD-064-M.AV.R	125 064 011 0102

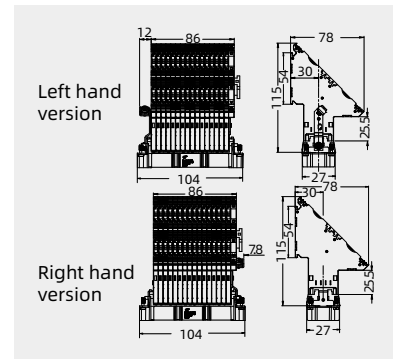

Female, Screw terminal



Size	Description	Designation	Order No.
24B	left hand version	HD-064-F.AV.L	125 064 021 0101
24B	right hand version	HD-064-F.AV.R	125 064 021 0102

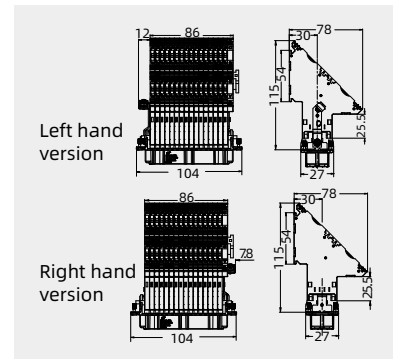

Using the fixing element can secure the HD AV insert inside the switch cabinet on standard rails.

### Fixing element



Description	Designation	Order No.
for terminal block connector	FE-DAV	198 002 003 0034

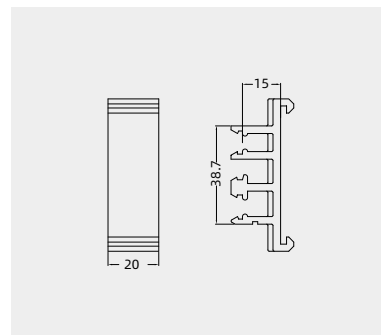

### Examples for Installstion

#### Introductions

HD-040,HD-064 =2pcs

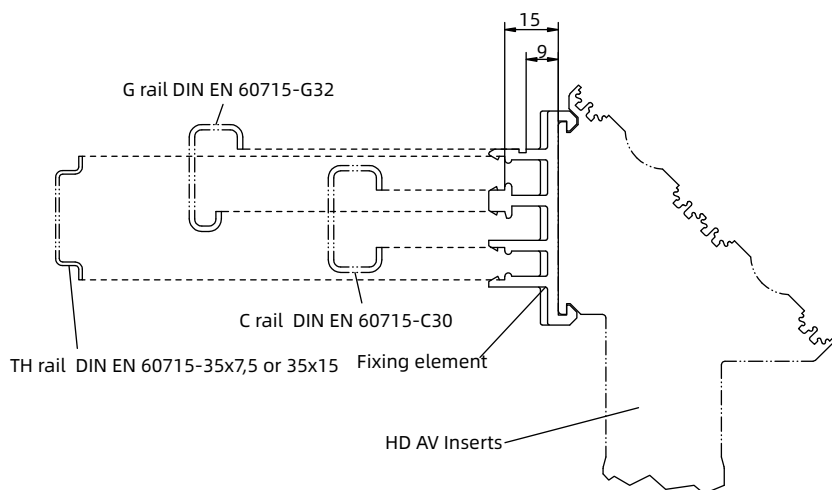

## HE AV/HD AV Assembly

### HE AV Assembly

#### Possibilities in switch cabinet

The connector can be mounted in the switch cabinet on the left or right side, therefore it is allowed to use the same prepared interface cable.

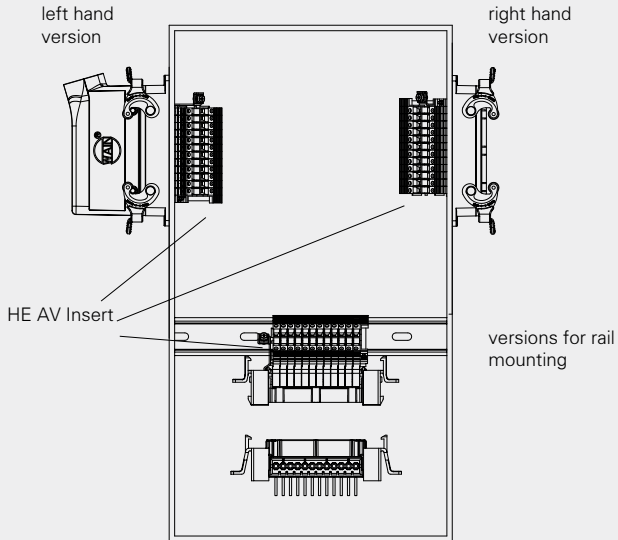

#### Assembly of terminal block connectors

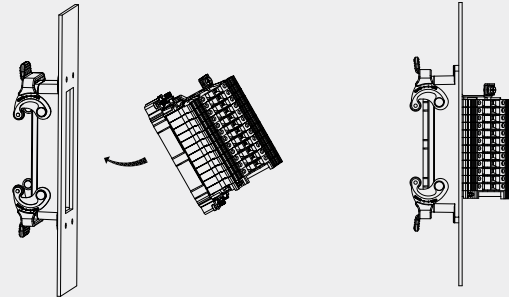

**Method I: installed on standard 24B bulkhead housings**  
Install the insert on the housing from the the inside of the cabinet with a 45° angle, and the ground connection must be installed first. After the insert is completely installed in the housing, lock the insert with four grounding screws.

### HD AV Assembly

#### Possibilities in switch cabinet

The connector can be mounted in the switch cabinet on the left or right side, therefore it is allowed to use the same prepared interface cable.

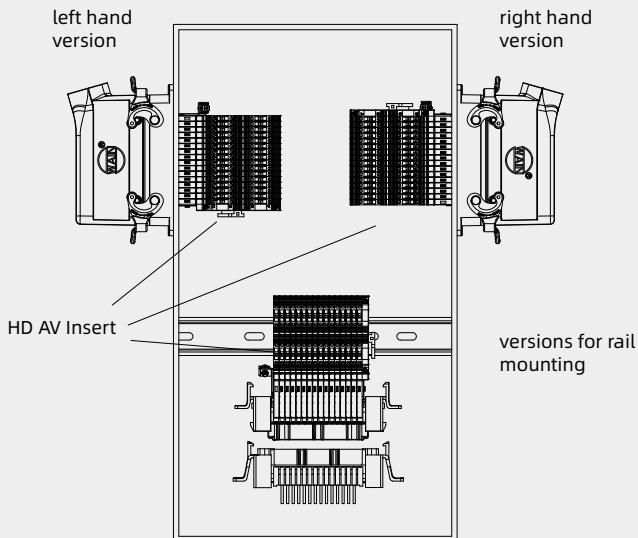

#### Assembly of terminal block connectors

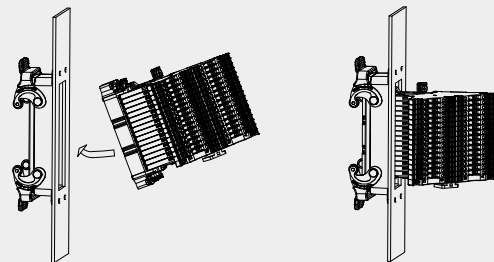

**Method I: installed on standard 24B bulkhead housings**  
Install the insert on the housing from the the inside of the cabinet with a 45° angle, and the ground connection must be installed first. After the insert is completely installed in the housing, lock the insert with four grounding screws.

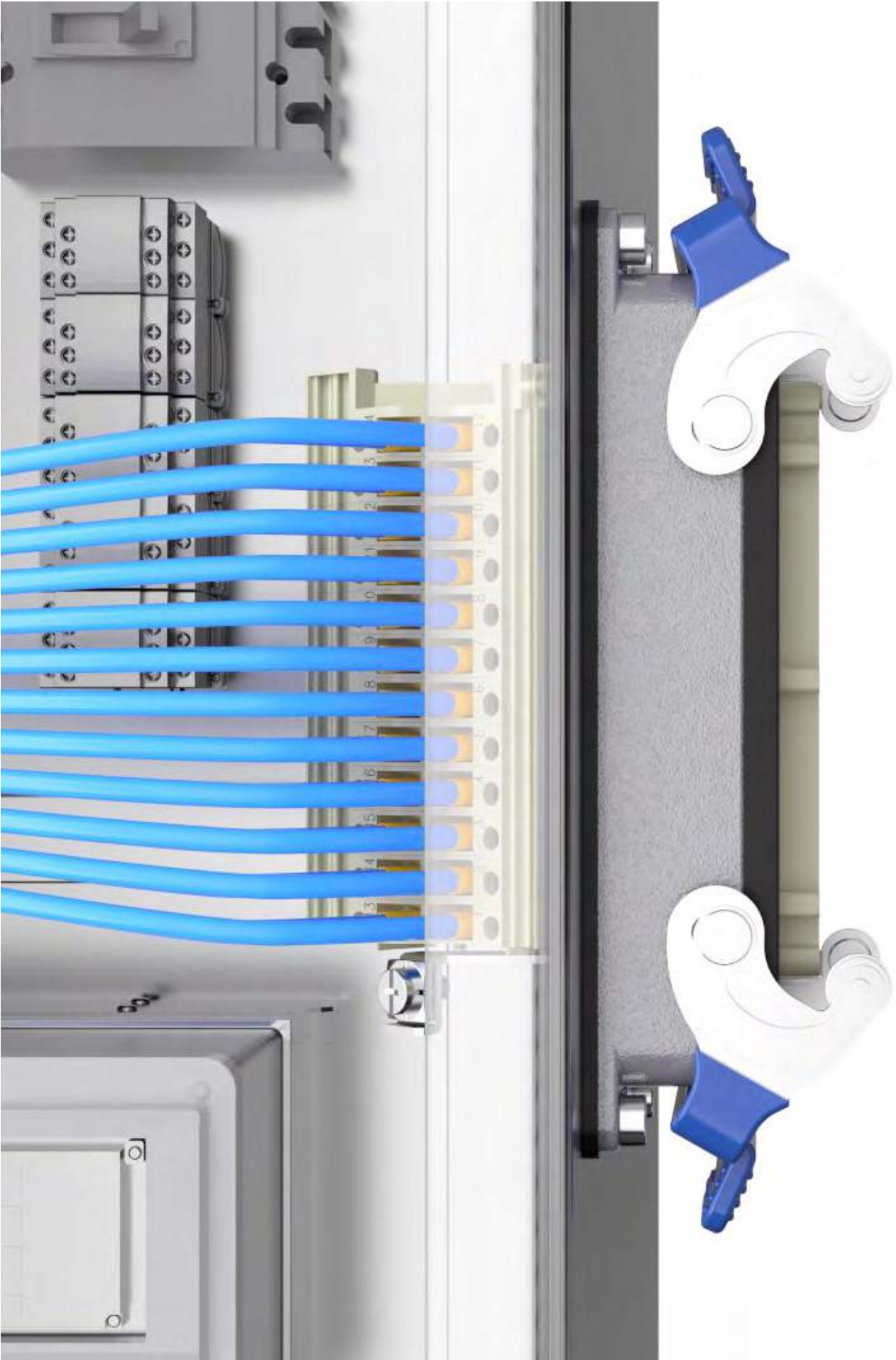









# HM SERIES

Flexible and combined connector







## Summary





Insert	300A Crimp module	200A Axial module	200A Crimp module	100A Crimp module
Contacts	1	1	1	1
Terminal	Crimp terminal	Axial screw terminal	Crimp terminal	Crimp terminal
				
Rated current	300A	200A	200A	100A
Rated voltage	1000V AC 1300V DC	1000V	1000V	830V
Wire gauge	25-70mm <sup>2</sup>	25-70mm <sup>2</sup>	25-70mm <sup>2</sup>	10-35mm <sup>2</sup>





Insert	100A Axial module	100A Crimp module	70A Axial module	70A Crimp module
Contacts	2	2	2	2
Terminal	Axial screw terminal	Crimp terminal	Axial screw terminal	Crimp terminal
				
Rated current	100A	100A	70A	70A
Rated voltage	1000V	1000V	1000V	1000V
Wire gauge	10-35mm <sup>2</sup>	10-35mm <sup>2</sup>	6-22mm <sup>2</sup>	10-25mm <sup>2</sup>





Insert	40A Axial module	40A Crimp module	40A Axial module	40A Crimp module
Contacts	2	2	3	3
Terminal	Axial screw terminal	Crimp terminal	Axial screw terminal	Crimp terminal
				
Rated current	40A	40A	40A	40A
Rated voltage	1000V	1000V	690V	500V
Wire gauge	2.5-10mm <sup>2</sup>	1.5-10mm <sup>2</sup>	2.5-10mm <sup>2</sup>	1.5-10mm <sup>2</sup>

Insert	40A Crimp module	40/10A Crimp module	40A Crimp module	40A High voltage module
Contacts	3	3/4	4	2
Terminal	Crimp terminal	Crimp terminal	Crimp terminal	Crimp terminal
				
Rated current	40A	40A/10A	40A	40A
Rated voltage	690V	830V	830V	2900/5000V
Wire gauge	1.5-6mm <sup>2</sup>	1.5-6mm <sup>2</sup> /0.37-2.5mm <sup>2</sup>	1.5-6mm <sup>2</sup>	1.5-10mm <sup>2</sup>



## Summary

Insert	16A High voltage module	16A Screw module	16A Cage-clamp module	16A Crimp module
Contacts	2	5	5	6
Terminal	Crimp terminal	Screw terminal	Cage clamp terminal	Crimp terminal
				
Rated current	16A	16A	16A	16A
Rated voltage	2900/5000V	230/400V	400V	500V
Wire gauge	0.37-4mm <sup>2</sup>	0.14-4mm <sup>2</sup>	0.14-2.5mm <sup>2</sup>	0.14-4mm <sup>2</sup>

Insert	16A Spring module	16A Protected module	16A Crimp module	16A Spring module
Contacts	6	6	8	8
Terminal	spring terminal(Quick-in)	Crimp terminal	Crimp terminal	spring terminal(Quick-in)
				
Rated current	16A	16A	16A	16A
Rated voltage	500V	830V	400V	400V
Wire gauge	0.5-4mm <sup>2</sup>	0.14-4mm <sup>2</sup>	0.14-4mm <sup>2</sup>	0.5-4mm <sup>2</sup>

Insert	16A Crimp module	10A Crimp module	10A Spring module	10A Crimp module
Contacts	20	12	12	17
Terminal	Crimp terminal	Crimp terminal	spring terminal(Quick-in)	Crimp terminal
				
Rated current	16A	10A	10A	10A
Rated voltage	500V	250V	250V	160V
Wire gauge	0.14-4mm <sup>2</sup>	0.14-2.5mm <sup>2</sup>	0.5-2.5mm <sup>2</sup>	0.14-2.5mm <sup>2</sup>

## HM

Insert	10A Crimp module	Shielded module		
Contacts	42	24+Shielded		
Terminal	Crimp terminal	Crimp terminal		
				
Rated current	10A	4A		
Rated voltage	150V	32V		
Wire gauge	0.14-2.5mm <sup>2</sup>	0.09-0.52mm <sup>2</sup>		







## Summary





Insert	5A D-Sub module	5A D-Sub module	5A D-Sub module 2	1A USB module
Contacts	9	9	9	25
Terminal	Crimp terminal	Crimp terminal	Crimp terminal	Crimp terminal
				
Rated current	5A	5A	5A	4A
Rated voltage	50V	50V	50V	50V
Wire gauge	0.09-0.82mm <sup>2</sup>	0.09-0.82mm <sup>2</sup>	0.09-0.82mm <sup>2</sup>	



Insert	1A USB module	4A High Density module	4A High Density module	1A RJ45 module
Contacts	4	25	36	8
Terminal	Module for patch cable	Crimp terminal	Crimp terminal	Module for patch cable
				
Rated current	1A	4A	4A	1A
Rated voltage	50V	50V	32V	50V
Wire gauge		0.09-0.52mm <sup>2</sup>	0.09-0.52mm <sup>2</sup>	









Insert	H3A RJ45	H3A RJ45	H3A RJ45	HM-RJ45
Contacts	4 (data) + 4 (power) / 8 (data) + 4 (power)	8	8	8
				
Rated current	1A	1.5A	1.5A	1A
Rated voltage	48V	125V	125V	50V
Transmission features	Category 5 / Class E up to 500 MHz ; Category 6 / Class E up to 500 MHz	Category 5 / Class E up to 500 MHz	Category 6 / Class E up to 500 MHz	Category 6 / Class E up to 500 MHz









## Summary

Insert	Axial grounding module	plastics module	Axial grounding module	Crimp module
Contacts	1	1	1	1
Terminal	Axial screw terminal	Screw terminal	Axial screw terminal	Crimp terminal
				
Wire gauge	25-70mm <sup>2</sup>	1.5-16mm <sup>2</sup>	10-35mm <sup>2</sup>	10-35mm <sup>2</sup>

Insert	MegaBit Insert	MegaBit Insert	MegaBit Insert	MegaBit Insert
Contacts	2x4	2x4	2x4+Shielded	8+Shielded
Number of outlet holes	1	1	2	
				
		Not allow to connect with the frame shield		
Rated current	10A	10A	10A	5A
Rated voltage	50V	150V	50V	50V
Wire gauge	0.14-2.5mm <sup>2</sup>	0.14-2.5mm <sup>2</sup>	0.14-2.5mm <sup>2</sup>	0.09-0.82mm <sup>2</sup>

Insert	Adapter module	Adapter module	Cable clamp	
Contacts	1	1		
Terminal	for MegaBit Insert and	for 24 pins shielded module	for 100M,1000M and 24 pins modules	
				
			Clamping range:5-14mm	

Insert	Pneumatic module	Pneumatic module	Pneumatic Module(Metal Contact)	Pneumatic Module(Metal Contact)
Contacts	2	3	3	3
				
Contacts	 $\Phi 6$ mm	 $\Phi 1.6$ mm $\Phi 3.0$ mm $\Phi 4.0$ mm	 $\Phi 3.0$ mm $\Phi 4.0$ mm $\Phi 6.0$ mm	 $\Phi 3.0$ mm $\Phi 4.0$ mm $\Phi 6.0$ mm

Insert	Electromagnetic screening module				Fiber module	
Contacts	2				4	
						
Contacts						
	Q-Coax 4+shielding	High Density Q-Coax 8+shielding	D Coax 1+shielding	E Coax 1+shielding	single: 9/125 $\mu$ m	multimode: 50/125 $\mu$ m or 62.5/125 $\mu$ m

Insert	Electromagnetic screening module				SC Fibe	
Contacts	2				4	
						
Contacts						
	Q-Coax 4+shielding	High Density Q-Coax 8+shielding	D Coax 1+shielding	E Coax 1+shielding	single: 9/125 $\mu$ m	multimode: 50/125 $\mu$ m or 62.5/125 $\mu$ m

## Hinged frames

### Technical characteristics

Number of modules	2,3,4,6
PE contact(Wire gauge)	
- Power side	4-10mm <sup>2</sup> 【Use PE-E16,expandable to 16mm <sup>2</sup> ; (see page P10-20 for details). Only suitable for high structure hood or BK housing. 】 AWG 12-8
- Signal side	1-2.5mm <sup>2</sup> 18-14
Material	zinc die-cast
Limiting temperatures	-40°C ...+125°C
Mechanical working life(mating cycles)	≥ 500

### Frame construction version 1

Unit: mm

#### 6B frame, size 6B hoods/housings



Application	Marking	Designation	Order No.
for 2 modules	A-B	HF6B-NUA3	129 006 000 1004
for 2 modules	a-b	HF6B-NLA3	129 006 000 1003

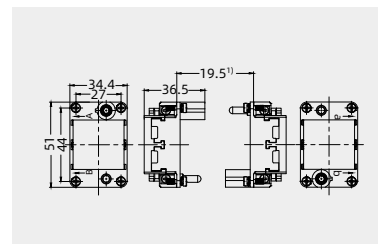

#### 10B frame, size 10B hoods/housings



Application	Marking	Designation	Order No.
for 3 modules	A-C	HF10B-NUA3	129 010 000 1004
for 3 modules	a-c	HF10B-NLA3	129 010 000 1003

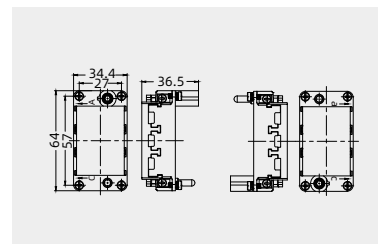

#### 16B frame, size 16B hoods/housings



Application	Marking	Designation	Order No.
for 4 modules	A-D	HF16B-NUA3	129 016 000 1004
for 4 modules	a-d	HF16B-NLA3	129 016 000 1003

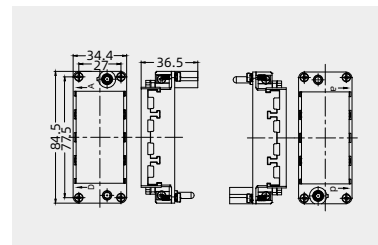

#### 24B frame, size 24B hoods/housings



Application	Marking	Designation	Order No.
for 6 modules	A-F	HF24B-NUA3	129 024 000 1004
for 6 modules	a-f	HF24B-NLA3	129 024 000 1003

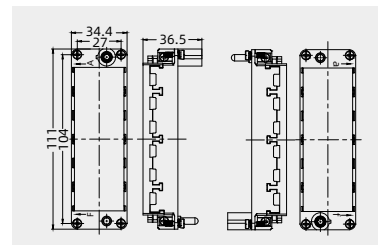

## Hinged frames

### Technical characteristics

Number of modules	2,3,4,6
PE contact(Wire gauge)	
- Power side	4-10mm <sup>2</sup> 【Use PE-E16,expandable to 16mm <sup>2</sup> ;Use PE-E25,expandable to 25mm <sup>2</sup> ;(see page P10-20 for details). Only suitable for high structure hood or BK housing. 】 AWG 12-8
- Signal side	1-2.5mm <sup>2</sup> 18-14
Material	zinc die-cast
Limiting temperatures	-40°C ...+125°C
Mechanical working life(mating cycles)	≥ 500

### Frame construction version 2

Unit: mm

#### 6B frame, size 6B hoods/housings



Application	Marking	Designation	Order No.
for 2 modules	A-B	HF6B-NUA2	129 006 000 1002
for 2 modules	a-b	HF6B-NLA2	129 006 000 1001

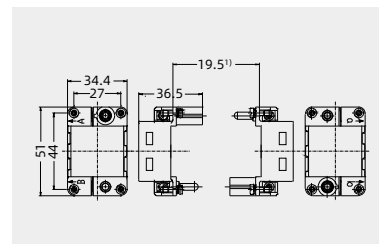

#### 10B frame, size 10B hoods/housings



Application	Marking	Designation	Order No.
for 3 modules	A-C	HF10B-NUA2	129 010 000 1002
for 3 modules	a-c	HF10B-NLA2	129 010 000 1001

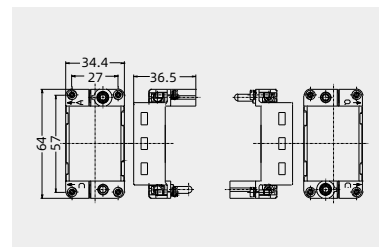

#### 16B frame, size 16B hoods/housings



Application	Marking	Designation	Order No.
for 4 modules	A-D	HF16B-NUA2	129 016 000 1002
for 4 modules	a-d	HF16B-NLA2	129 016 000 1001

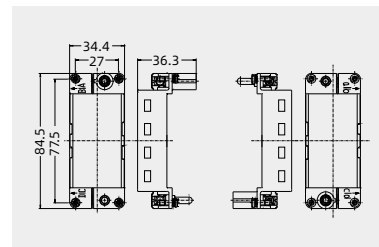

#### 24B frame, size 24B hoods/housings



Application	Marking	Designation	Order No.
for 6 modules	A-F	HF24B-NUA2	129 024 000 1002
for 6 modules	a-f	HF24B-NLA2	129 024 000 1001

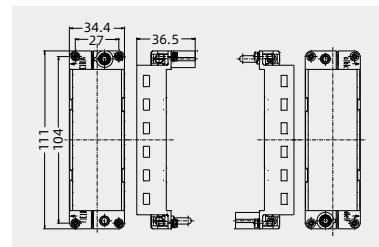

#### Locking element



Application	Designation	Order No.
Ideal topre-assemble the hinged frames	HF-LE2	198 002 003 0024

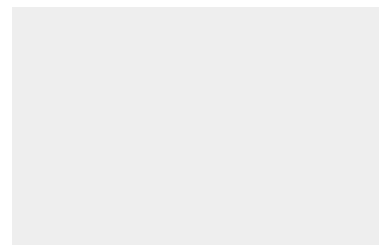

## Hinged frames

## Technical characteristics

Number of modules	8
PE contact(Wire gauge)	
- Power side	4-10mm <sup>2</sup> AWG 12-8
- Signal side	1-2.5mm <sup>2</sup> 18-14
Material	zinc alloy + Stainless steel
Limiting temperatures	-40°C ...+125°C
Mechanical working life(mating cycles)	≥ 500

## Frame construction version



Unit: mm

24B frame, Suitable for 12-26 only, plus large housing



Application	Marking	Designation	Order No.
for 2 modules	A-H	HF24B/E-NUA	129 024 000 1521
for 2 modules	a-h	HF24B/E-NLA	129 024 000 1522

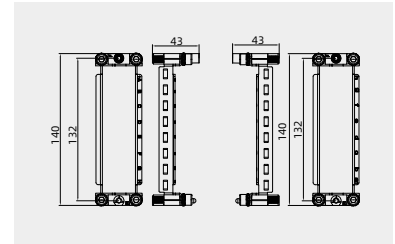

## Metal Docking Frame

### Technical characteristics

Number of modules	2+PE, 3+PE, 4+PE, 6+PE
Material	zinc die-cast
Limiting temperatures	-40°C ...+125°C
Mechanical working life(mating cycles)	≥ 500

### Single module frame docking stand

Unit: mm



Application	Marking	Designation	Order No.
for 1 modules	/		198 002 004 0019
for 1 modules	/	HF1M-FADK	198 002 004 0020

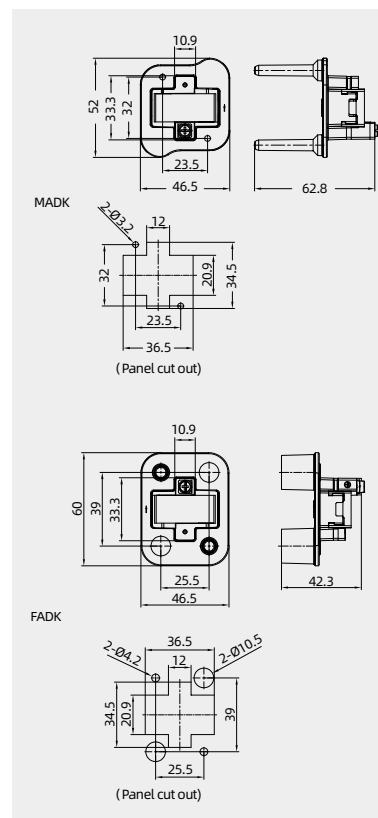

### Floating washer

#### Floating washer

Describe	Designation	Order No.
Floating tolerance ±4	HF-ADK-D12	198 002 001 0004
Floating tolerance ±3	HF-ADK-D15	198 002 001 0003

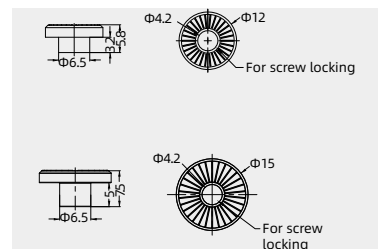

## Metal Docking Frame

### Technical characteristics

Number of modules	2+PE, 3+PE, 4+PE, 6+PE
Material	zinc die-cast
Limiting temperatures	-40°C ...+125°C
Mechanical working life(mating cycles)	≥ 500

## Metal Docking Frame

Unit: mm

### 6B Metal Docking Frame

Application	Marking	Designation	Order No.
for 2 modules	A-B	HF6B-MADK	131 006 000 1006
for 2 modules	a-b	HF6B-FADK	131 006 000 1005

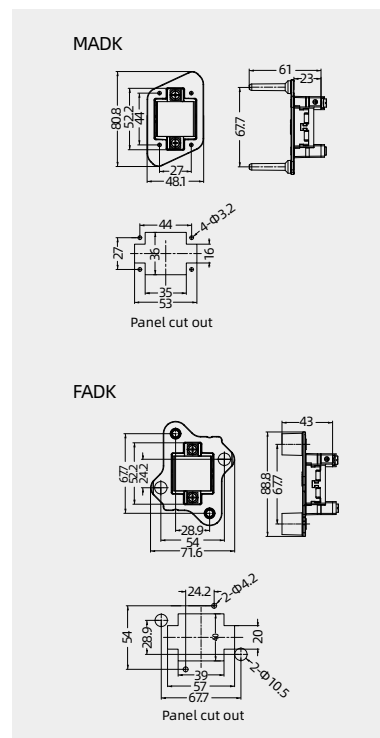

## Floating washer

### Floating washer

Describe	Designation	Order No.
Floating tolerance ±4	HF-ADK-D12	198 002 001 0004
Floating tolerance ±3	HF-ADK-D15	198 002 001 0003

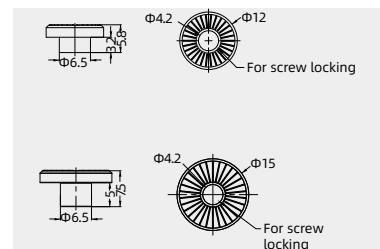



# Metal Docking Frame

## Technical characteristics

Number of modules	2+PE, 3+PE, 4+PE, 6+PE
Material	zinc die-cast
Limiting temperatures	-40°C ...+125°C
Mechanical working life(mating cycles)	≥ 500

## Metal Docking Frame

Unit: mm

### 16B Metal Docking Frame

Application	Marking	Designation	Order No.
for 4 modules	A-D	HF16B-MADK	131 016 000 1005
for 4 modules	a-d	HF16B-FADK	131 016 000 1004

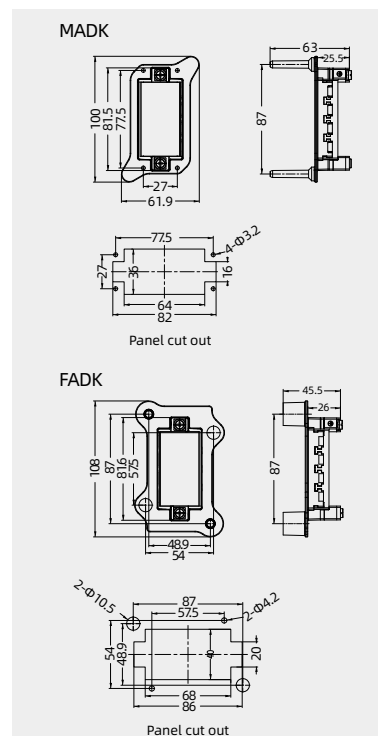

## Floating washer

### Floating washer

Describe	Designation	Order No.
Floating tolerance $\pm 4$	HF-ADK-D12	198 002 001 0004
Floating tolerance $\pm 3$	HF-ADK-D15	198 002 001 0003

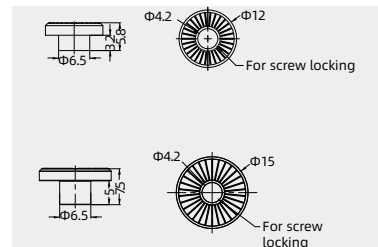

## Metal Docking Frame

### Technical characteristics

Number of modules	6+PE
Material	zinc die-cast
Limiting temperatures	-40°C ...+125°C
Mechanical working life(mating cycles)	≥ 500

## Metal Docking Frame

Unit: mm

### 24B Metal Docking Frame

Application	Marking	Designation	Order No.
for 6 modules	A-F	HF24B-MADK	131 024 000 1004
for 6 modules	a-f	HF24B-FADK	131 024 000 1014

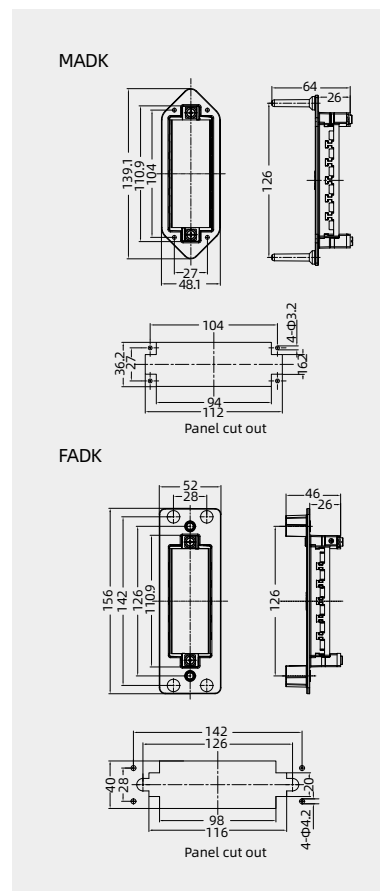

HM

## Floating washer

### Floating washer

Describe	Designation	Order No.
Floating tolerance ±4	HF-ADK-D12	198 002 001 0004
Floating tolerance ±3	HF-ADK-D15	198 002 001 0003

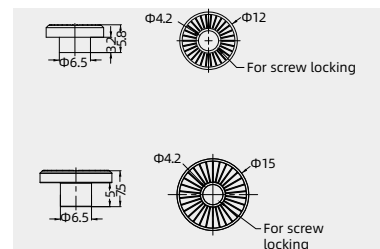

# Plastic Docking Frame

## Technical characteristics

Number of modules	3
Material	polycarbonate
Limiting temperatures	-40°C ...+125°C
Mechanical working life(mating cycles)	≥ 500
Floating tolerance	±2mm
Lock tolerance	±4mm

## Plastic Docking Frame

Unit: mm

### 10B plastic docking frame



Application	Marking	Designation	Order No.
for 3 modules	a-c	HF10B.P-MADK	111 010 100 1501
for 3 modules	A-C	HF10B.P-FADK	111 010 100 1500

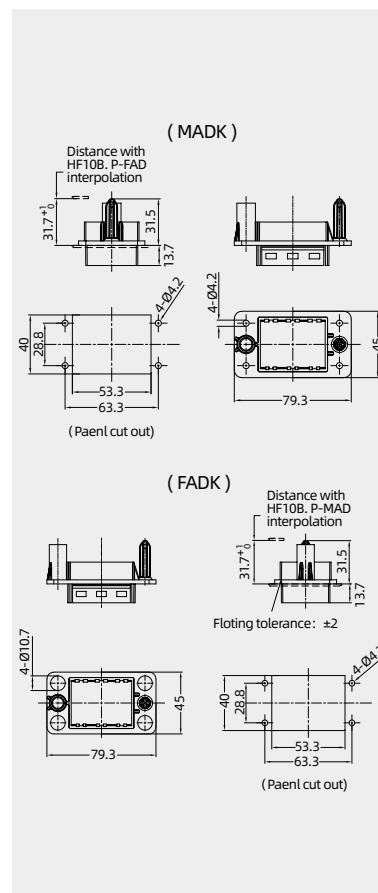

## Floating washer

### Floating washer



Describe	Designation	Order No.
Floating tolerance ±3	HF-ADK-D15	198 002 001 0003

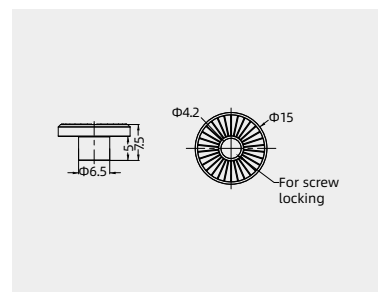

## Plastic Docking Frame

### Technical characteristics

Number of modules	3
Material	polycarbonate
Limiting temperatures	-40°C ...+125°C
Mechanical working life(mating cycles)	≥ 500
Floating tolerance	±2mm
Lock tolerance	±4mm

## Plastic Docking Frame

Unit: mm

### 24B plastic docking frame



Application	Marking	Designation	Order No.
for 6 modules	a-f	HF24B.P-MADK	111 024 100 1501
for 6 modules	A-F	HF24B.P-FADK	111 024 100 1500

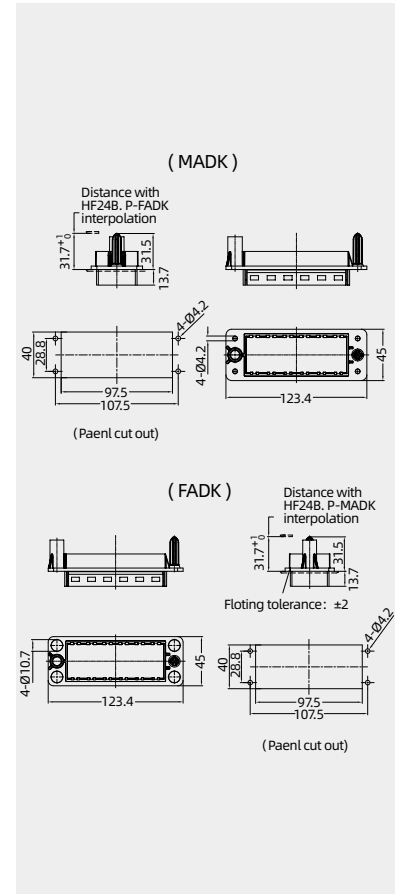

HM

## Floating washer

### Floating washer



Describe	Designation	Order No.
Floating tolerance ±3	HF-ADK-D15	198 002 001 0003

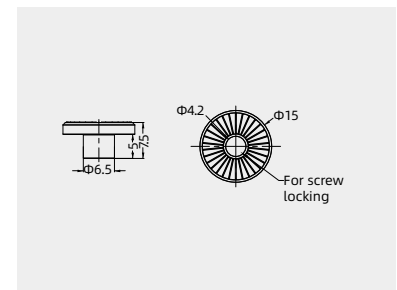

## Plastic Docking Frame

### Technical characteristics

Number of modules	4
Material	polycarbonate
Limiting temperatures	-40°C ...+125°C
Mechanical working life(mating cycles)	≥ 500
Floating tolerance	±3mm
Lock tolerance	±4mm

## Plastic Docking Frame

Unit: mm

### 24B Plastic sliding butt frame



Application	Marking	Designation	Order No.
for 4 modules	A-F	HF16B.P-MASK	101 000 099 0180
for 4 modules	a-f	HF16B.P-FASK	101 000 099 0179
		HFxB.P-MASK-APT	101 000 099 0181

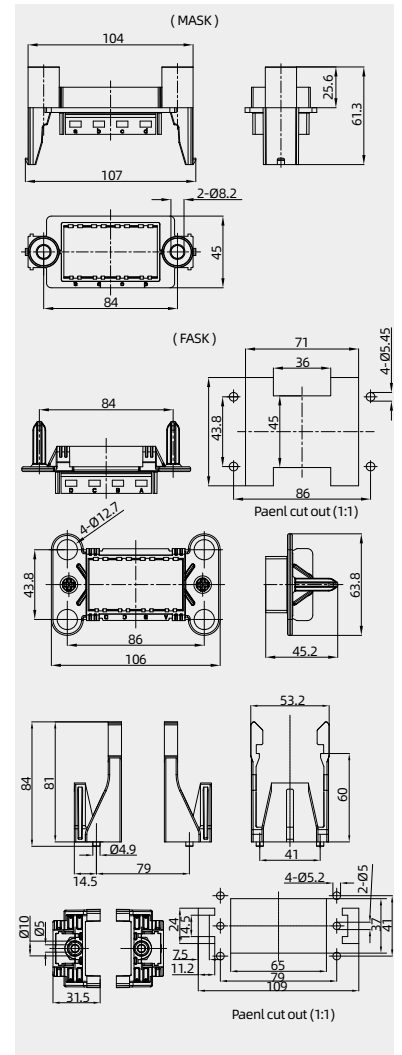

### Floating washer

#### Floating washer

Describe	Designation	Order No.
Floating tolerance ±4	HF-ADK-D12	198 002 001 0004

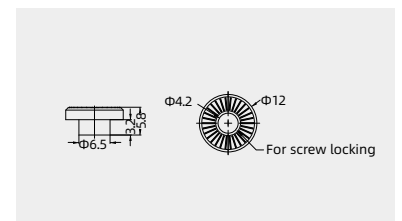

## Modules dismounting instructions



### Frame construction version 1 Modules dismounting instructions

Assembly instructions

Disassembly process is on the contrary.

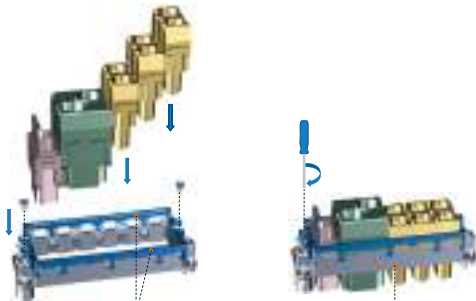

Loosen sliding border before assembly After finished assembly,close sliding border,lock screw

### Frame construction version 2 Modules dismounting instructions

Assembly instructions

Disassembly instructions

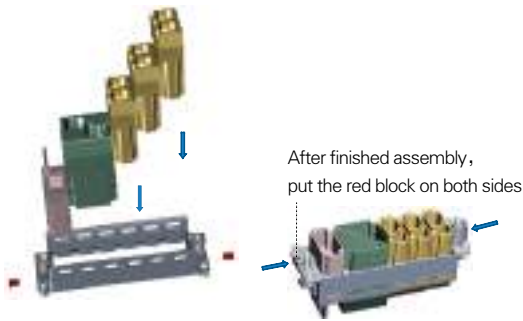

After finished assembly, put the red block on both sides

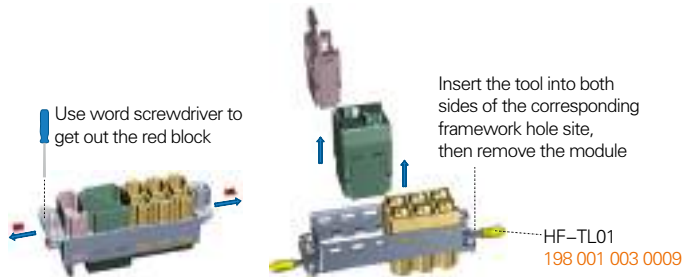

Insert the tool into both sides of the corresponding framework hole site, then remove the module

HF-TL01  
198 001 003 0009

HM

### PE contact Assembly instructions

Step 1: insert the stripped wire into the hole of the PE contact for crimping. (Reference stripping length 15mm<sup>±1</sup> )

Step 2: Insert the crimped PE contact into the frame's grounding pin power cable (large hole) and lock the locking screw of the frame ground pin ( Recommended tightening torque is 1.2Nm)



## Metal enclosure for single module

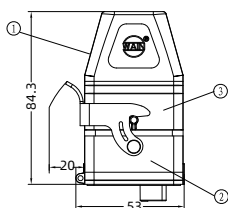

### Component

The connector is only applicable to one module, and it provides a degree of protection of IP65.

- ① Top entry of the hood;
- ② Housing with a stainless steel locking lever;
- ③ Carrier hood.

## Hoods/Housings

### Hoods, side entry



Thread	Designation	Order No.
M25	H1M-SE-M25	129 001 590 1003

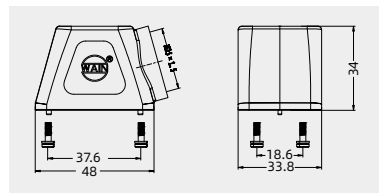

### Hoods, top entry



Thread	Designation	Order No.
M25	H1M-TE-M25	129 001 490 1003

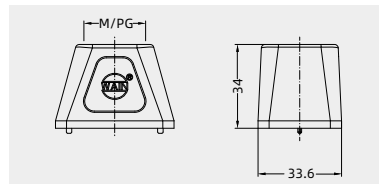

### Hoods, top entry



Thread	Designation	Order No.
M32	H1M-TE-M32	129 001 490 1004

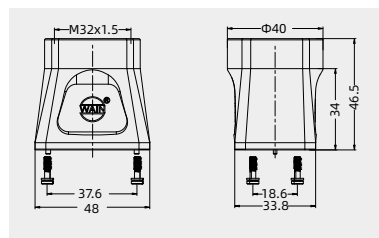

### Carrier hood



Thread	Designation	Order No.
---	H1M-MBK-2B	129 001 310 1001

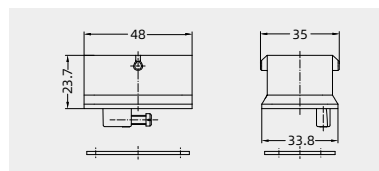

### Bulkhead mounted housings



Thread	Designation	Order No.
---	H1M-BK-1L/S	129 001 325 1001

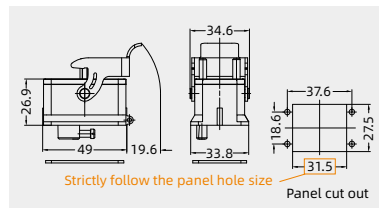

### Protection covers, plastic



Thread	Designation	Order No.
---	H1M-CV-1L/1	129 001 025 8001

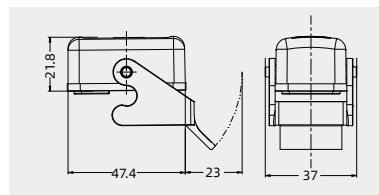

### Protection covers (for Housings), plastic



Thread	Designation	Order No.
---	H1M-CV-2B/2	129 001 010 8002

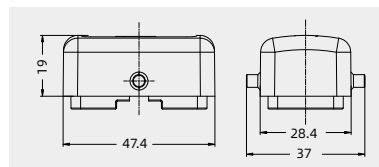

HM

# Metal enclosure for single module(EMC)-PUSH LOCK

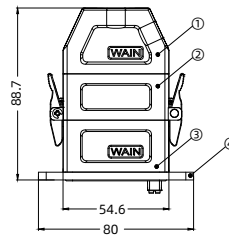
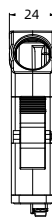

## Component

- ① Hood with top or side entry;
- ② Carrier hood with locking device;
- ③ Housing, bulkhead mounted;
- ④ Mounting plate.

## Hoods/Housings

### Hoods, side entry



Thread	Designation	Order No.
M20	EMC.H1M.WU-SE-M20	129 001 590 1102

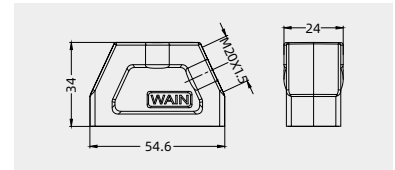

### Hoods, top entry



Thread	Designation	Order No.
M20	EMC.H1M.WU-TE-M20	129 001 490 1102

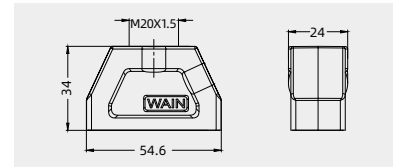

### Carrier hood



Thread	Designation	Order No.
---	EMC.H1M.WU-MBK-2L	129 001 340 1001

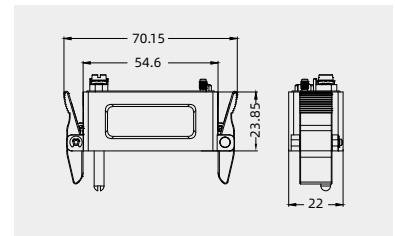

### Bulkhead mounted housings



Thread	Designation	Order No.
---	EMC.H1M.WU-BK	129 001 300 1001

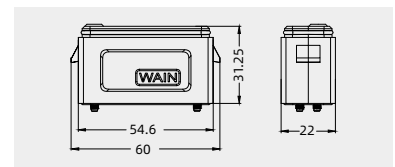

### Mounting plate



Thread	Designation	Order No.
---	EMC.H1M.WU-MP	129 001 000 1101

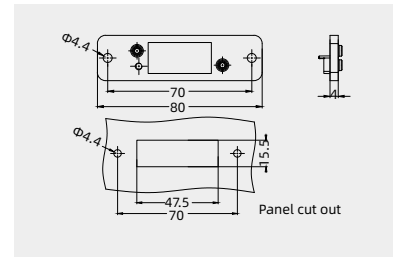

### Coding element



Thread	Designation	Order No.
for Carrier hood Male	CODE-Q7M	198 002 005 0007
for Housings Female	CODE-Q7F	198 002 005 0008

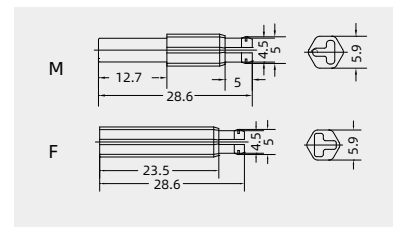



## Metal enclosure for single module(EMC)

### Product features

1. More compact, more powerful
2. Robust metal hoods/housings: zinc die-cast
3. Easy installation with the innovative PUSH LOCK
4. Protection against mismatching, thanks to hexagonal coding
5. Grounding solution for potential equalization
6. Large selection of standard modules
7. EMC design.



### Assembly instructions

Step 1: cable will pass through cable connector. After crimping with pin (taking cold pressing pin as an example), it will be installed in male module (taking male module as an example), grounding wire will be locked at corresponding binding post of middle housing; the cable will pass through installation plate, which will be installed in the female module after crimping with pin, grounding wire will be locked at corresponding binding post; coding plug pin will be installed at selected direction, CODE-Q7M will be installed on middle housing and CODE-Q7F will be installed on the lower housing;

Step 2: cross screwdriver will be used to lock M3 screws on the middle housing and upper housing tightly to fix the male module; cross screwdriver will be used to lock M3 screws on the lower housing and face plate tightly to fix the female module; the cable connector will be tightened;

Step 3: after insertion, installation is completed.

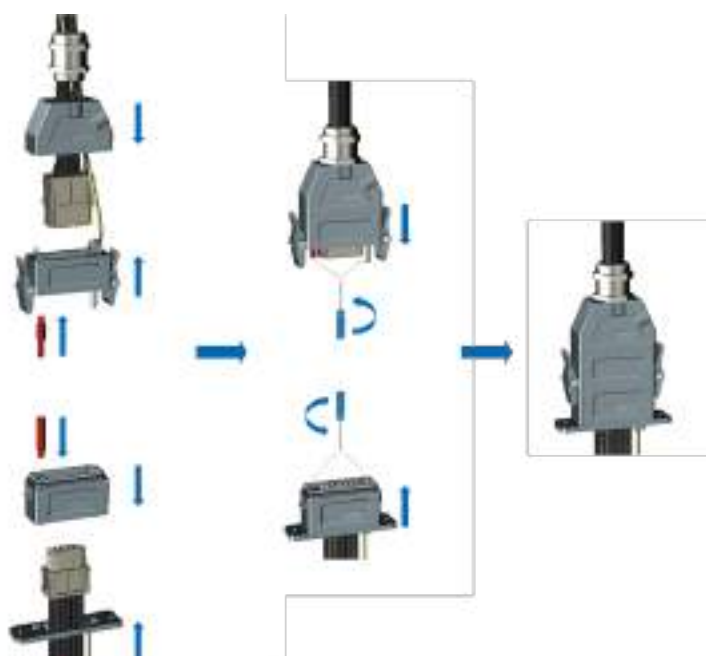

## H2M metal enclosure for double module (EMC)

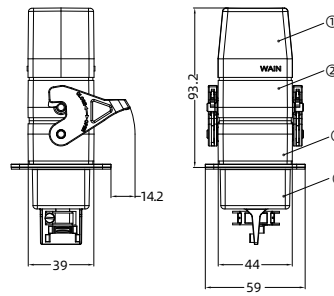

### Component

- ① Hood with top or side entry;
- ② Carrier hood;
- ③ Housing with lever;
- ④ Mounting plate.

## Hoods/Housings

### Hoods, side entry



Thread	Designation	Order No.
M25	H2M-SE-M25	129 002 500 1001

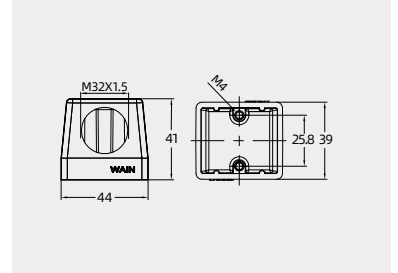

### Hoods, top entry



Thread	Designation	Order No.
M25	H2M-TE-M25	129 002 400 1002
M32	H2M-TE-M32	129 002 400 1001

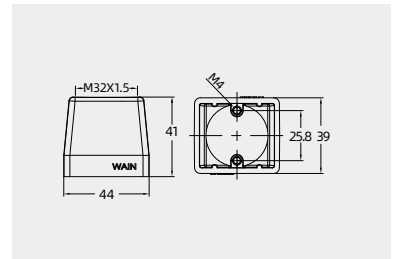

### Carrier hood



Thread	Designation	Order No.
---	H2M-MBK-2B	129 002 310 1001

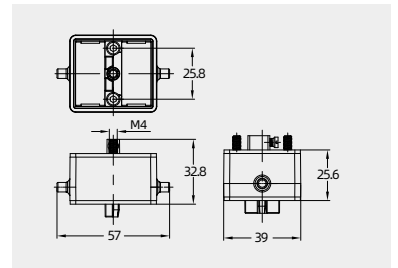

### Bulkhead mounted housings



Thread	Designation	Order No.
---	H2M-BK-1L	129 002 320 1001

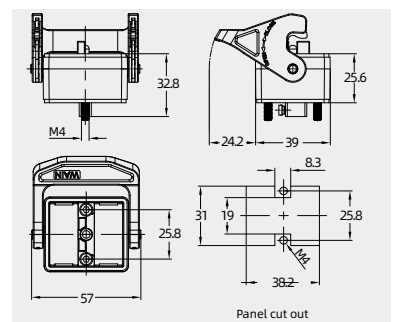

HM

### Mounting plate



Thread	Designation	Order No.
---	H2M-2CLP/BK	129 002 300 1001

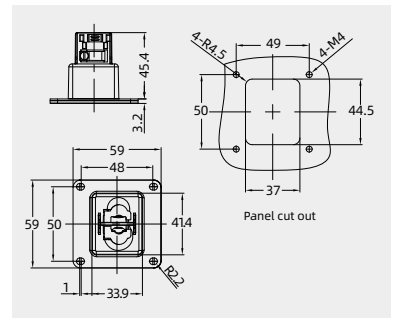

## H2M metal enclosure for double module (EMC)

### Product features

1. More compact, more powerful;
2. Five entry choices for hood;
3. Grounding solution for potential equalization;
4. Protection against mismatching;
5. EMC design;
6. Matching a variety of single module inserts, and can be used any two single module inserts at the same time.

### Assembly instructions

Step 1: Cable will pass through cable gland. After crimping with contact (taking crimp contact as an example), it will be installed in male module (taking male module as an example), grounding wire will be locked at corresponding binding post of middle housing; the cable will pass through installation plate, which will be installed in the female module after crimping with contact, grounding wire will be locked at corresponding binding post;

Step 2: SW3 internal hexagonal wrench will be used to lock M4 screws on the middle housing and hood tightly to fix the male module; internal hexagonal wrench will be used to lock M4 screws on the housing and installation plate tightly to fix the female module; the cable gland will be tightened;

Step 3: After insertion and locking the lever, installation is completed.

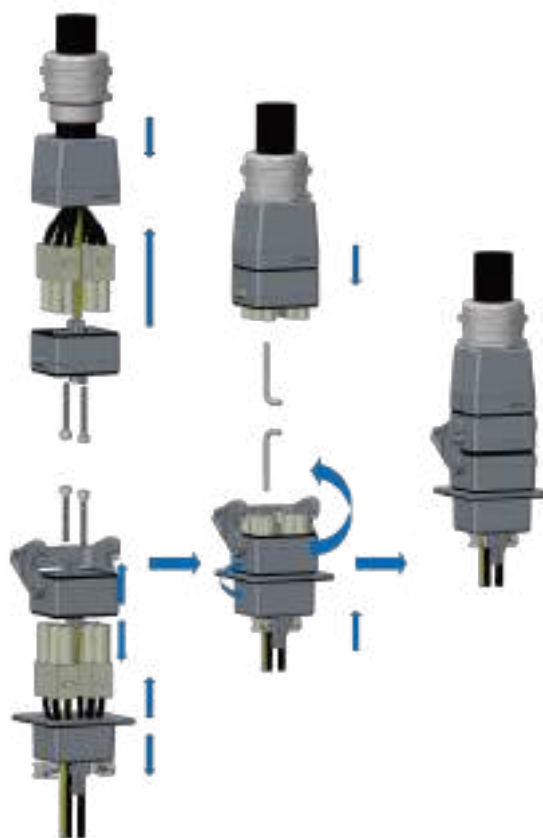

HM

Modular Accessories

Unit: mm

Dummy module



Description	Designation	Order No.
It is used to fill the spare module space in the fixed frame	HM-000	198 002 099 0008

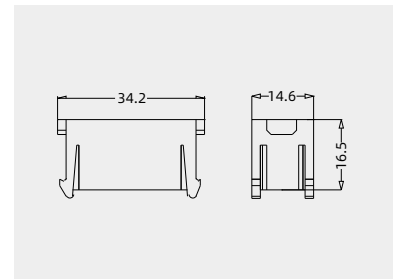

Module clamp



Description	Designation	Order No.
Applicable to with claw module, without strain relief	HM-CP1	198 002 003 0026

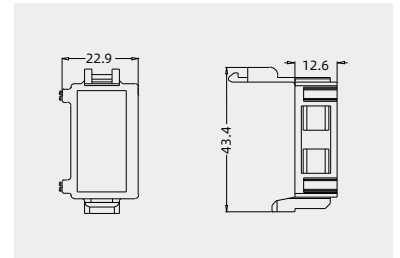

Module clamp



Description	Designation	Order No.
Applicable to with claw module, with strain relief -available to fix wires	HM-CP2	198 002 003 0027

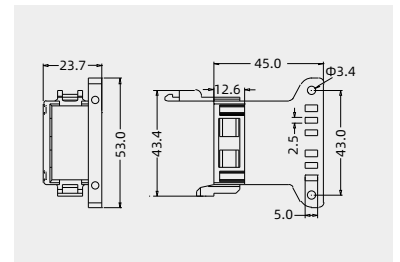

Module clamp



Description	Designation	Order No.
Applicable to module, with strain relief -available to fix wires	HM-CP2/2	198 002 003 0030

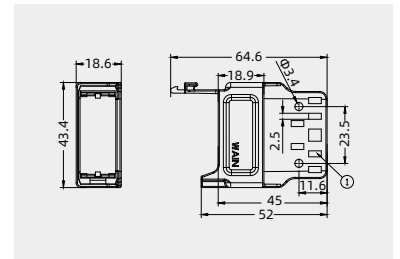

Unit: mm

Module clamp



Description	Designation	Order No.
Applicable to with claw module module, for rail	HM-CP3	198 002 003 0028

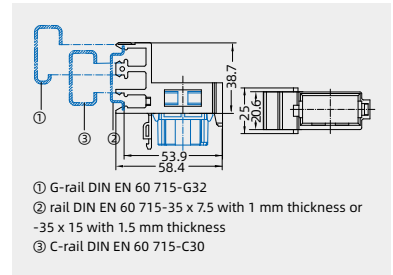

Module clamp



Description	Designation	Order No.
Applicable to module, for rail	HM-CP3/2	198 002 003 0029

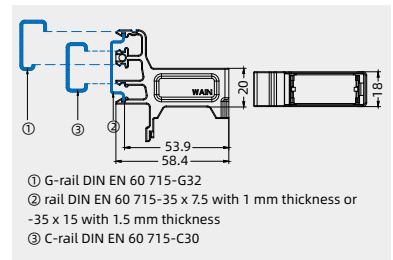

Hinged frame, size 10A hoods/housings



Description	Designation	Order No.
for 1 module	HF10A	129 010 000 1091

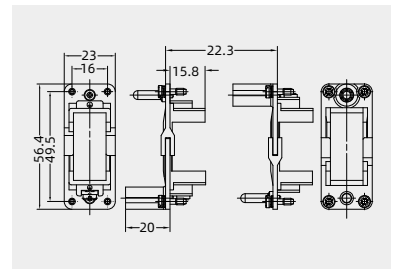

Grounding module



Description	Designation	Order No.
Only suitable for modular type plastic hoods/housings	HMPE-001-M	129 001 001 0505
	HMPE-001-F	129 001 002 0503

Only suitable for modular type plastic hoods/housings, Please refer to P15-25.1, P15-25.2, P15-39.1, P15-39.2, P15-108.2, P15-108.3

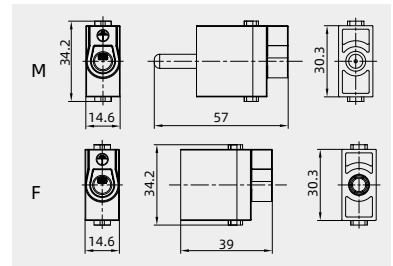

## H2MK300-001 Crimp module

1000V 300A

Inserts



Combination with hinged frame and other modules possible.

## Technical characteristics

Specifications	DIN EN 60 664 DIN EN 61 984
Approvals	
Inserts	Contacts
Number of contacts	1
Electrical data acc. to EN 61 984	Material
- Rated current	100A
- Rated voltage	830V
- Rated impulse voltage	8kV
- Pollution degree	3
Insulation resistance	$\geq 10^{10}\Omega$
Material	polycarbonate
Limiting temperatures	-40°C ... +125°C
Flammability acc. to UL 94	V0
Mechanical working life	$\geq 500$
- mating cycles	
	Surface
	hard-silver plated
	Contact resistance
	$\leq 0.3m\Omega$
	Crimp terminal
	- mm <sup>2</sup>
	70-120mm <sup>2</sup>
	- Stripping length
	23.5mm
	(When the outer diameter of the cable insulation layer $\geq 22$ mm, male contact : 31mm, Female contact : 29.5mm)

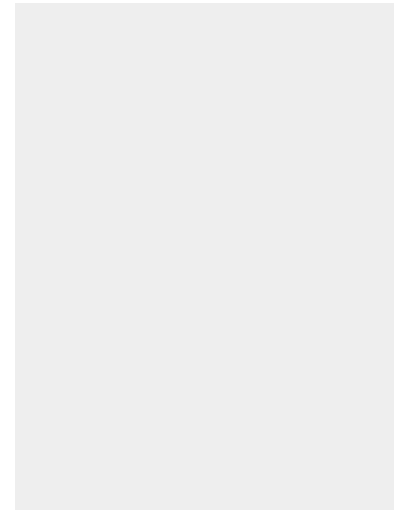

## Crimp terminal

Order crimp contacts separately

Insert	Designation	Order No.
Male	H2MK300-001-MC	129 001 010 0510
Female	H2MK300-001-FC	129 001 020 0510

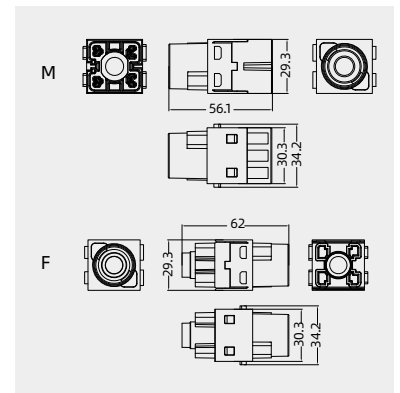

## Crimp contacts

Crimp contacts 300A

Contact resistance  $\leq 0.3 m\Omega$   
silver plated

Male	Order No.	Female	Order No.
CHSM300-70	101 041 110 1950	CHSF300-70	101 041 120 1950
CHSM300-95	101 041 110 2050	CHSF300-95	101 041 120 2050
CHSM300-120	101 041 110 2150	CHSF300-120	101 041 120 2150

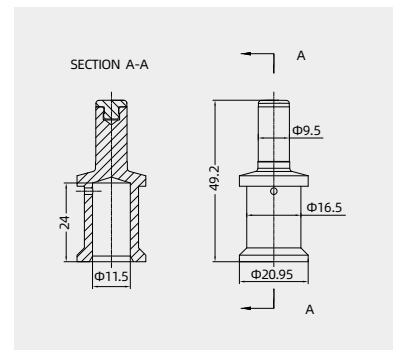

## Tools

Manual hydraulic clamp

Wire gauge	Designation	Order No.
10-240mm <sup>2</sup>	TL05	198 001 001 0005



Notes: The tools for crimp terminal may influence the product quality and stability.  
Please select the tools recognized by our company.

# H2MK-001 Axial module

1000V 200A

## Inserts



Combination with hinged frame and other modules possible.

## Technical characteristics

Specifications	DIN EN 60 664 DIN EN 61 984		
Approvals	UL, CE, ENEC		
Inserts		Contacts	
Number of contacts	1	Material	copper alloy
Electrical data acc. to EN 61 984		Surface	hard-silver plated
-Rated current	200A	Contact resistance	0.2mΩ
-Rated voltage	1000V	For stranded wire according to IEC 60 228 Class 5	
-Rated impulse voltage	8kV	Screw terminal	
-Pollution degree	3	- Wire gauge	25-70mm <sup>2</sup>
Rated voltage acc. to UL	600V	- AWG	2-0
Insulation resistance	≥ 10 <sup>10</sup> Ω	- Hexagonal driver	SW 5
Material	polycarbonate	- Stripping length	16mm
Limiting temperatures	-40°C ...+125°C	- Tightening torque	
Flammability acc. to UL 94	V0	-mm <sup>2</sup>	25 35 50 70
Mechanical working life	≥ 500	-Nm	8 8 9 10
- mating cycles			

### Current carrying capacity

The current carrying is limited by maximum temperature of materials for inserts and contacts including terminals

Control and test procedures according to DIN EN 60512-5

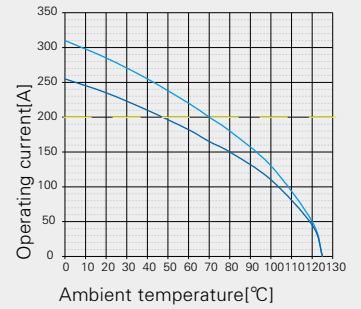

- 24 B hoods/housings with 3 modules, wire gauge: 70mm<sup>2</sup>
- 24 B hoods/housings with 3 modules, wire gauge: 50mm<sup>2</sup>

## Axial screw terminal<sup>1)</sup>



Insert	Wire gauge	Designation	Order No.
Male	25-40mm <sup>2</sup>	H2MK-001.1-M (25-40mm <sup>2</sup> )	129 001 011 0101
	40-70mm <sup>2</sup>	H2MK-001.2-M (40-70mm <sup>2</sup> )	129 001 011 0102
Female	25-40mm <sup>2</sup>	H2MK-001.1-F (25-40mm <sup>2</sup> )	129 001 021 0101
	40-70mm <sup>2</sup>	H2MK-001.2-F (40-70mm <sup>2</sup> )	129 001 021 0102

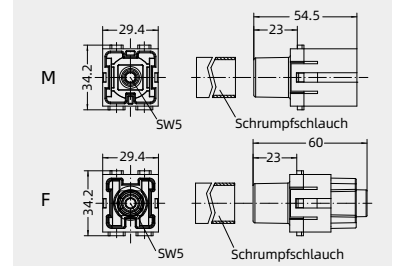

## Accessories

### Tool

hexagonal driver



Description	Designation	Order No.
for axial setscrew with grip	SW-5*150	198 001 003 0007

<sup>1)</sup> See P00-12-00-13 for the structural characteristics and description of Axial screw terminal.

## H2MKPE-001 Axial grounding module

1000V 200A+

### Inserts



Combination with hinged frame and other modules possible.

### Technical characteristics

Specifications	DIN EN 60 664	
	DIN EN 61 984	
<b>Approvals</b>		
<b>Inserts</b>		
Number of contacts	1	<b>Contacts</b>
Limiting temperatures	-40°C ...+125°C	Material
Mechanical working life	≥ 500	Surface
- mating cycles		For stranded wire according
Max. insulation diameter	-	Crimp terminal
Material	polycarbonate	-mm <sup>2</sup>
Surface	-	- AWG
		- Hexagonal driver
		- Stripping length
		- Tightening torque
		-mm <sup>2</sup>
		-Nm

### Current carrying capacity

The current carrying is limited by maximum temperature of materials for inserts and contacts including terminals

Control and test procedures according to DIN EN 60512-5

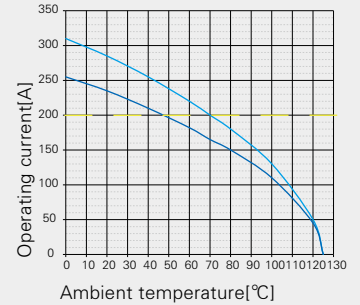

- 24 B hoods/housings with 3 modules, wire gauge: 70mm<sup>2</sup>
- 24 B hoods/housings with 3 modules, wire gauge: 50mm<sup>2</sup>

### Axial screw terminal<sup>1)</sup>



Insert	Wire gauge	Designation	Order No.
Male	25-40mm <sup>2</sup>	H2MKPE-001.1-M(25-40mm <sup>2</sup> )	129 001 011 0001
	40-70mm <sup>2</sup>	H2MKPE-001.2-M(40-70mm <sup>2</sup> )	129 001 011 0002
Female	25-40mm <sup>2</sup>	H2MKPE-001.1-F(25-40mm <sup>2</sup> )	129 001 021 0001
	40-70mm <sup>2</sup>	H2MKPE-001.2-F(40-70mm <sup>2</sup> )	129 001 021 0002

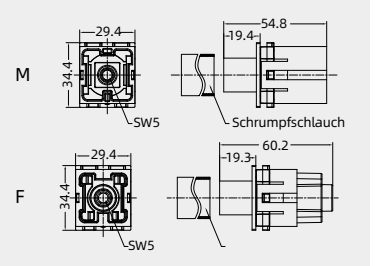

### Accessories

#### Tool

hexagonal driver



Description	Designation	Order No.
for axial setscrew with grip	SW-5*150	198 001 003 0007



# H2MK-001 Crimp module

1000V 200A

## Inserts



Combination with hinged frame and other modules possible.

## Technical characteristics

Specifications	DIN EN 60 664 DIN EN 61 984		
Approvals			
Inserts		Contacts	
Number of contacts	1	Material	copper alloy
Electrical data acc. to EN 61 984		Surface	hard-silver plated
-Rated current	200A	Contact resistance	≤ 0.3mΩ
-Rated voltage	1000V	Crimp terminal	
-Rated impulse voltage	8kV	- mm <sup>2</sup>	25-70mm <sup>2</sup>
-Pollution degree	3	Stripping length	22.5mm
Insulation resistance	≥ 10 <sup>10</sup> Ω	Max. insulation diameter	18mm
Material	polycarbonate		
Limiting temperatures	-40°C ...+125°C		
Flammability acc. to UL 94	V0		
Mechanical working life			
- mating cycles	≥ 500		

### Current carrying capacity

The current carrying is limited by maximum temperature of materials for inserts and contacts including terminals

Control and test procedures according to DIN EN 60512-5

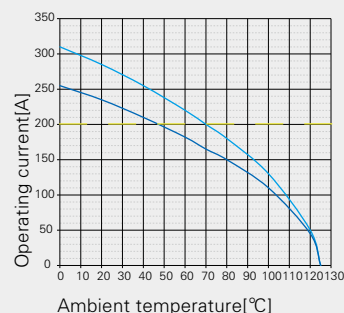

— 24 B hoods/housings with 3 modules, wire gauge: 70mm<sup>2</sup>  
 — 24 B hoods/housings with 3 modules, wire gauge: 50mm<sup>2</sup>

## Crimp terminal

Order crimp contacts separately



Insert	Designation	Order No.
Male	H2MK-001-MC	129 001 010 0101
Female	H2MK-001-FC	129 001 020 0101

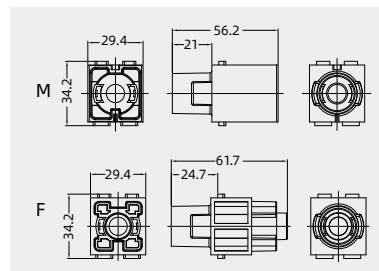

## Crimp contacts

Crimp contacts 200A

Contact resistance ≤ 0.3 mΩ  
silver plated



Male	Order No.	Female	Order No.
CHSM200-25	101 027 110 1601	CHSF200-25	101 027 120 1601
CHSM200-35	101 027 110 1701	CHSF200-35	101 027 120 1701
CHSM200-50	101 027 110 1801	CHSF200-50	101 027 120 1801
CHSM200-70	101 027 110 1901	CHSF200-70	101 027 120 1901

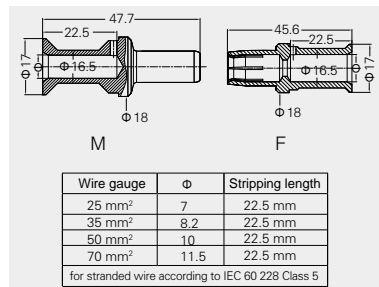

## Tools

Manual hydraulic clamp



Wire gauge	Designation	Order No.
10-240mm <sup>2</sup>	TL05	198 001 001 0005

Notes: The tools for crimp terminal may influence the product quality and stability. Please select the tools recognized by our company.

## H2MK-001 Crimp module

1000V 200A

### Inserts



Combination with hinged frame and other modules possible.

### Technical characteristics

Specifications	DIN EN 60 664 DIN EN 61 984
----------------	--------------------------------

Inserts		Contacts	
Number of contacts	1	Material	copper alloy
Electrical data acc. to EN 61 984		Surface	hard-silver plated
-Rated current	200A	Contact resistance	≤ 0.3mΩ
-Rated voltage	1000V	Crimp terminal	
-Rated impulse voltage	8kV	- mm <sup>2</sup>	25-70mm <sup>2</sup>
-Pollution degree	3	Stripping length	22.5mm
Insulation resistance	≥ 10 <sup>10</sup> Ω	Max. insulation diameter	18mm
Material	polycarbonate		
Limiting temperatures	-40°C ...+125°C		
Flammability acc. to UL 94	V0		
Mechanical working life			
- mating cycles	≥ 500		



### Crimp terminal

Order crimp contacts separately

Insert	Designation	Order No.
Male	H2MK-001-MC/C	129 001 010 0512
Female	H2MK-001-FC/C	129 001 020 0512

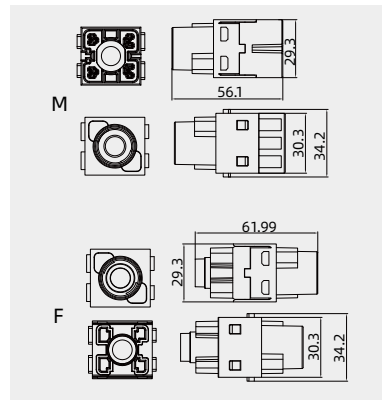
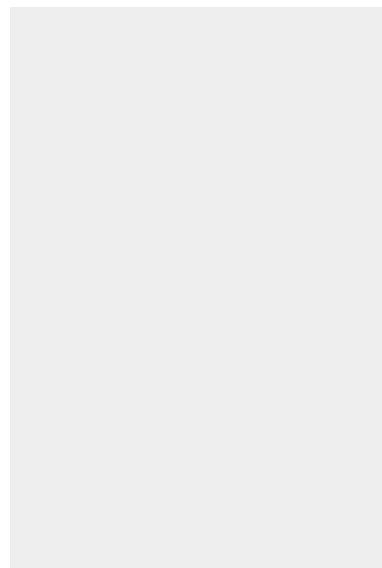

Not compatible with 200A module (10-16/10-18), compatible with 300A module (10-15.1)

### Crimp contacts

#### Crimp contacts 200A

Contact resistance ≤ 0.3 mΩ silver plated

Male	Order No.	Female	Order No.
CHSM200-25	101 027 110 1601	CHSF200-25	101 027 120 1601
CHSM200-35	101 027 110 1701	CHSF200-35	101 027 120 1701
CHSM200-50	101 027 110 1801	CHSF200-50	101 027 120 1801
CHSM200-70	101 027 110 1901	CHSF200-70	101 027 120 1901

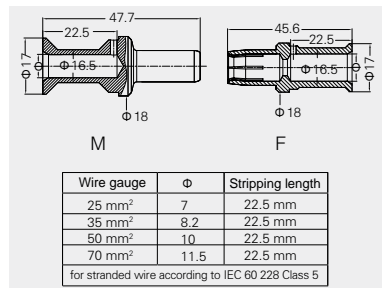

### Tools

#### Manual hydraulic clamp

Wire gauge	Designation	Order No.
10-240mm <sup>2</sup>	TL05	198 001 001 0005



Notes: The tools for crimp terminal may influence the product quality and stability. Please select the tools recognized by our company.

10-18.1 WAIN ELECTRICAL

# HMK-001 Crimp module

830V 100A

## Inserts



Combination with hinged frame and other modules possible.  
Cannot match the metal hood with side entry:EMC.H1M.WU-SE-M20.

## Technical characteristics

Specifications	DIN EN 60 664 DIN EN 61 984		
Approvals			
Inserts		Contacts	
Number of contacts	1	Material	copper alloy
Electrical data acc. to EN 61 984		Surface	hard-silver plated
-Rated current	100A	Contact resistance	≤ 0.3mΩ
-Rated voltage	830V	Crimp terminal	
-Rated impulse voltage	8kV	-mm <sup>2</sup>	10-35mm <sup>2</sup>
-Pollution degree	3		
Insulation resistance	≥ 10 <sup>10</sup> Ω		
Material	polycarbonate		
Limiting temperatures	-40°C ...+125°C		
Flammability acc. to UL 94	V0		
Mechanical working life			
- mating cycles	≥ 500		
Max. insulation diameter	13mm		

## Crimp terminal

Order crimp contacts separately



Insert	Designation	Order No.
Male	HMK-001-MC	129 001 010 0001
Female	HMK-001-FC	129 001 020 0001

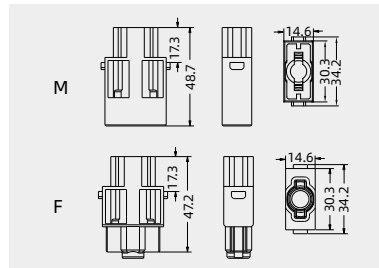

## Crimp contacts

Crimp contacts 100A

Contact resistance ≤ 0.3 mΩ  
silver plated



Male	Order No.	Female	Order No.
CKSM-10	101 026 110 1401	CKSF-10G	101 026 120 1403
CKSM-16	101 026 110 1501	CKSF-16G	101 026 120 1503
CKSM-25	101 026 110 1601	CKSF-25G	101 026 120 1603
CKSM-35	101 026 110 1701	CKSF-35G	101 026 120 1703

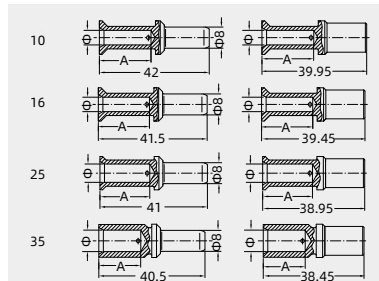

Wire gauge	φ	Stripping length(A)
10 mm <sup>2</sup>	4.3	19 mm
16 mm <sup>2</sup>	5.5	19 mm
25 mm <sup>2</sup>	7	19 mm
35 mm <sup>2</sup>	8.2	16 mm

for stranded wire acc. to IEC 60 228 Class 5

## Tools

Manual hydraulic clamp



Contact removal tool



Wire gauge	Designation	Order No.
10-240mm <sup>2</sup>	TL05	198 001 001 0005

Application	Designation	Order No.
for crimp contacts 100A	TL11	198 001 000 0018

Notes: The tools for crimp terminal may influence the product quality and stability.  
Please select the tools recognized by our company.

# HMPE.M Axial grounding module



Combination with hinged frame and other modules possible.

## Inserts

### Technical characteristics

Specifications	DIN EN 60 664 DIN EN 61 984		
Approvals			
Inserts	Contacts		
Number of contacts	1	Material	copper alloy
Limiting temperatures	-40°C ...+125°C	Surface	hard-silver plated
Mechanical working life		For stranded wire according	0.3mΩ
- mating cycles	≥ 500	to IEC 60 228 Class 5	
Material	zinc alloy	Screw terminal	
Surface	nickeling	- Wire gauge	10-35mm <sup>2</sup>
		- AWG	6-2
		- Hexagonal driver	SW 4
		- Stripping length	13mm
		- Tightening torque	
		-mm <sup>2</sup>	10 16 25 35
		-Nm	6 6 7 8

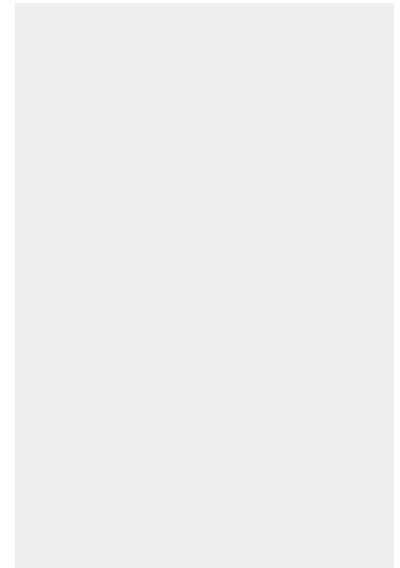

### Axial screw terminal<sup>1)</sup>



Insert	Wire gauge	Designation	Order No.
Male	10-25mm <sup>2</sup>	HMPE.M-001.1-M	129 001 001 0507
	16-35mm <sup>2</sup>	HMPE.M-001.2-M	129 001 001 0508
Female	10-25mm <sup>2</sup>	HMPE.M-001.1-F	129 001 002 0504
	16-35mm <sup>2</sup>	HMPE.M-001.2-F	129 001 002 0505

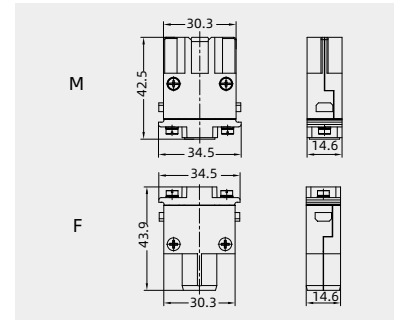

### Accessories

#### Tool

hexagonal driver



Description	Designation	Order No.
for axial setscrew with grip	SW-4*150	198 001 003 0007

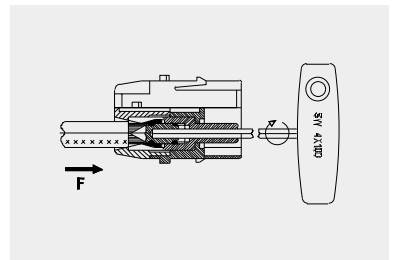

# HMPE.M Crimp grounding module



Combination with hinged frame and other modules possible.

## Inserts

### Technical characteristics

Specifications	DIN EN 60 664 DIN EN 61 984
Approvals	
Inserts	Contacts
Number of contacts	1
Limiting temperatures	-40°C ...+125°C
Mechanical working life	≥ 500
- mating cycles	
Max. insulation diameter	13mm
Material	zinc alloy
Surface	nickeling

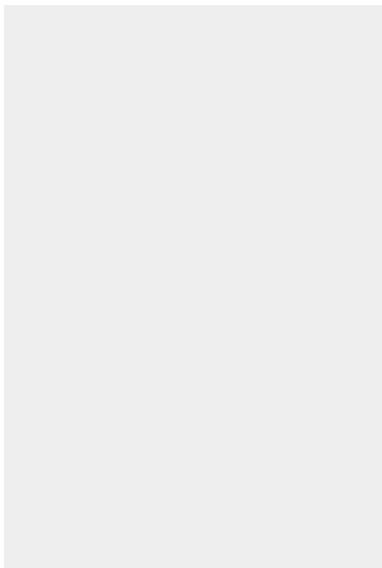

### Crimp terminal

Order crimp contacts separately



Insert	Designation	Order No.
Male	HMPE.M-001-MC	129 001 010 0511
Female	HMPE.M-001-FC	129 001 020 0511

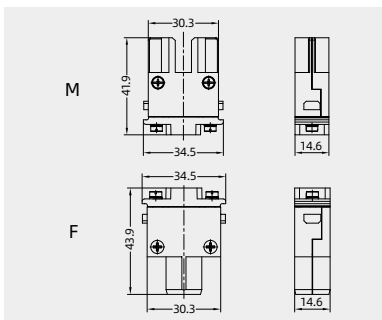

### Crimp contacts

Crimp contacts 100A  
Contact resistance ≤ 0.3 mΩ  
silver plated



Male	Order No.	Female	Order No.
CKSM-10	101 026 110 1401	CKSF-10G	101 026 120 1403
CKSM-16	101 026 110 1501	CKSF-16G	101 026 120 1503
CKSM-25	101 026 110 1601	CKSF-25G	101 026 120 1603
CKSM-35	101 026 110 1701	CKSF-35G	101 026 120 1703

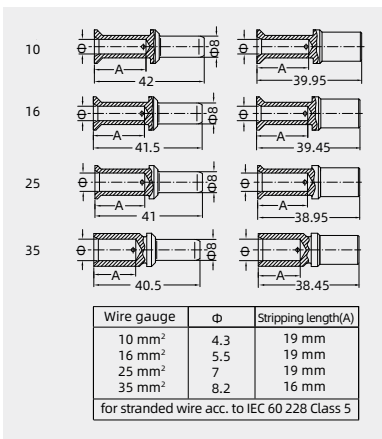

### Tools

Manual hydraulic clamp



Wire gauge	Designation	Order No.
10-240mm <sup>2</sup>	TL05	198 001 001 0005

Notes: The tools for crimp terminal may influence the product quality and stability. Please select the tools recognized by our company.

## H2MK-002 Axial module

1000V 100A

Inserts



Combination with hinged frame and other modules possible.

### Technical characteristics

Specifications	DIN EN 60 664 DIN EN 61 984		
Approvals			
Inserts		Contacts	
Number of contacts	2	Material	copper alloy
Electrical data acc. to EN 61 984		Surface	hard-silver plated
-Rated current	100A	Contact resistance	0.3mΩ
-Rated voltage	1000V	For stranded wire according to IEC 60 228 Class 5	
-Rated impulse voltage	8kV	Screw terminal	10-35mm <sup>2</sup>
-Pollution degree	3	- Wire gauge	6-2
Rated voltage acc. to UL	600V	- AWG	SW 4
Insulation resistance	≥ 10 <sup>10</sup> Ω	- Hexagonal driver	13mm
Material	polycarbonate	- Stripping length	
Limiting temperatures	-40°C ...+125°C	- Tightening torque	10 16 25 35
Flammability acc. to UL 94	V0	-mm <sup>2</sup>	6 6 7 8
Mechanical working life		-Nm	
- mating cycles	≥ 500		

#### Current carrying capacity

The current carrying is limited by maximum temperature of materials for inserts and contacts including terminals

Control and test procedures according to DIN EN 60512-5

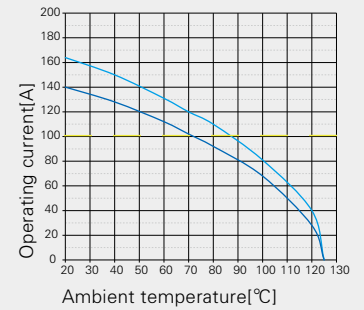

— 24 B hoods/housings with 3 modules, wire gauge: 35mm<sup>2</sup>  
 — 24 B hoods/housings with 3 modules, wire gauge: 25mm<sup>2</sup>

#### Axial screw terminal<sup>1)</sup>



Insert	Wire gauge	Designation	Order No.
Male	10-25mm <sup>2</sup>	H2MK-002.1-M (10-25mm <sup>2</sup> )	129 002 011 0101
	16-35mm <sup>2</sup>	H2MK-002.2-M (16-35mm <sup>2</sup> )	129 002 011 0102
Female	10-25mm <sup>2</sup>	H2MK-002.1-F (10-25mm <sup>2</sup> )	129 002 021 0101
	16-35mm <sup>2</sup>	H2MK-002.2-F (16-35mm <sup>2</sup> )	129 002 021 0102

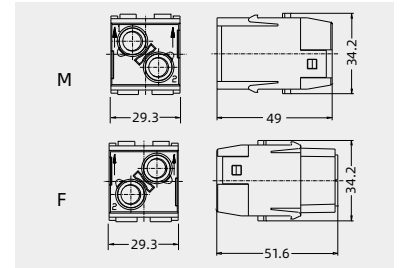

### Accessories

#### Cable shoe 16mm<sup>2</sup>



Description	Designation	Order No.
for PE extension	PE-E16 <sup>2)</sup>	198 002 006 0014

<sup>2)</sup> Use of PE pin is shown in P10-08.

#### Cable shoe 25mm<sup>2</sup>



Description	Designation	Order No.
for PE extension	PE-E25 <sup>2)</sup>	198 002 006 0020

<sup>2)</sup> Use of PE pin is shown in P10-08.  
 Suitable for metal frame: HFXB-NUA2/HFXB-NLA2

#### Tool

hexagonal driver



Description	Designation	Order No.
for axial setscrew with grip	SW-4*150	198 001 003 0001

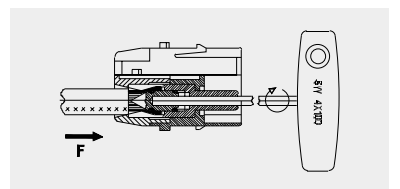
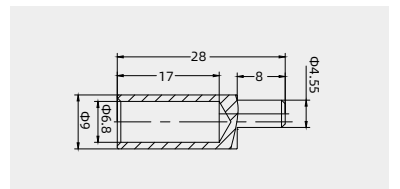
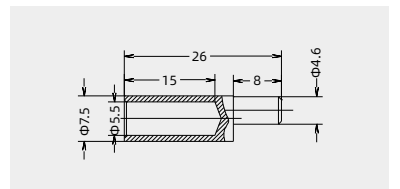

<sup>1)</sup> See P00-12-00-13 for the structural characteristics and description of Axial screw terminal.

# H2MK-002 Crimp module

1000V 100A

## Inserts



Combination with hinged frame and other modules possible.

## Technical characteristics

Specifications	DIN EN 60 664 DIN EN 61 984		
Approvals			
Inserts		Contacts	
Number of contacts	2	Material	copper alloy
Electrical data acc. to EN 61 984		Surface	hard-silver plated
-Rated current	100A	Contact resistance	≤ 0.3mΩ
-Rated voltage	1000V	Crimp terminal	
-Rated impulse voltage	8kV	- mm <sup>2</sup>	10-35mm <sup>2</sup>
-Pollution degree	3	Max. insulation diameter	14mm
Insulation resistance	≥ 10 <sup>10</sup> Ω		
Material	polycarbonate		
Limiting temperatures	-40°C ...+125°C		
Flammability acc. to UL 94	V0		
Mechanical working life			
- mating cycles	≥ 500		

### Current carrying capacity

The current carrying is limited by maximum temperature of materials for inserts and contacts including terminals

Control and test procedures according to DIN EN 60512-5

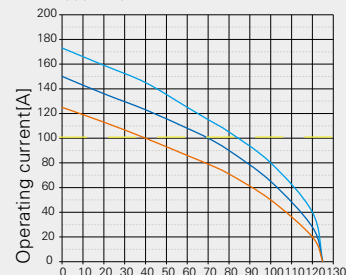

Ambient temperature [°C]

- 24 B hoods/housings with 3 modules, wire gauge: 35mm<sup>2</sup>
- 24 B hoods/housings with 3 modules, wire gauge: 25mm<sup>2</sup>
- 24 B hoods/housings with 3 modules, wire gauge: 16mm<sup>2</sup>

### Crimp terminal

Order crimp contacts separately



Insert	Designation	Order No.
Male	H2MK-002-MC	129 002 010 0101
Female	H2MK-002-FC	129 002 020 0101

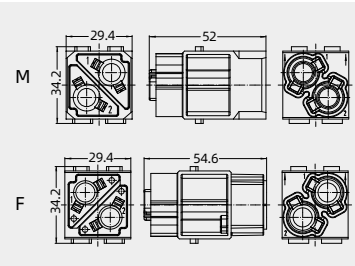

## Crimp contacts

### Crimp contacts 100A

Contact resistance ≤ 0.3 mΩ silver plated



Male	Order No.	Female	Order No.
CKSM-10	101 026 110 1401	CKSF-10G	101 026 120 1403
CKSM-16	101 026 110 1501	CKSF-16G	101 026 120 1503
CKSM-25	101 026 110 1601	CKSF-25G	101 026 120 1603
CKSM-35	101 026 110 1701	CKSF-35G	101 026 120 1703

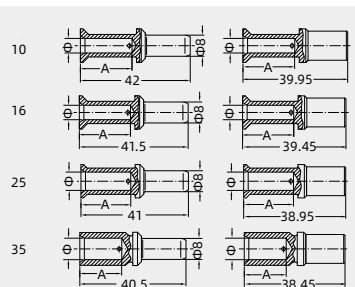

### Tools

Manual hydraulic clamp



Wire gauge	Designation	Order No.
10-240mm <sup>2</sup>	TL05	198 001 001 0005

Contact removal tool



Application	Designation	Order No.
for crimp contacts 100A	TL11	198 001 000 0018

Notes: The tools for crimp terminal may influence the product quality and stability. Please select the tools recognized by our company.

# HMK70-002 Axial module

1000V 70A

Inserts



Combination with hinged frame and other modules possible.

## Technical characteristics

Specifications	DIN EN 60 664 DIN EN 61 984		
Approvals	VDE CE ENEC		
Inserts		Contacts	
Number of contacts	2	Material	copper alloy
Electrical data acc. to EN 61 984		Surface	hard-silver plated
-Rated current	70A	Contact resistance	0.5mΩ
-Rated voltage	1000V	For stranded wire according to IEC 60 228 Class 5	
-Rated impulse voltage	8kV	Screw terminal	
-Pollution degree	3	-mm <sup>2</sup>	6-22mm <sup>2</sup>
Rated voltage acc. to UL	600V	-AWG	8-4
Insulation resistance	≥ 10 <sup>10</sup> Ω	-Hexagonal driver	SW 2.5
Material	polycarbonate	-Stripping length	
Limiting temperatures	-40°C ... +125°C	-mm <sup>2</sup>	6 10 16 22
Flammability acc. to UL 94	V0	-mm <sup>2</sup>	11 <sup>+1</sup> 11 <sup>+1</sup> 11 <sup>+1</sup> 12.5 <sup>+1</sup>
Mechanical working life		-Tightening torque	
- mating cycles	≥ 500	-mm <sup>2</sup>	6 10 16 22
		-Nm	2 3 4 5

### Current carrying capacity

The current carrying is limited by maximum temperature of materials for inserts and contacts including terminals

Control and test procedures according to DIN EN 60512-5

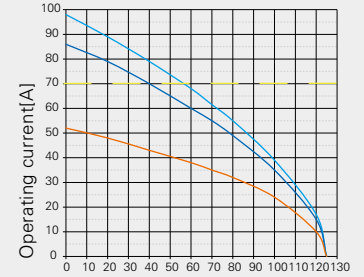

Ambient temperature [°C]

- 24 B hoods/housings with 6 modules, wire gauge: 22mm<sup>2</sup>
- 24 B hoods/housings with 6 modules, wire gauge: 16mm<sup>2</sup>
- 24 B hoods/housings with 6 modules, wire gauge: 6mm<sup>2</sup>

### Axial screw terminal<sup>1)</sup>



Insert	Wire gauge	Designation	Order No.
Male	6-16mm <sup>2</sup>	HMK70-002.1-M (6-16mm <sup>2</sup> )	129 002 011 0201
	14-22mm <sup>2</sup>	HMK70-002.2-M (14-22mm <sup>2</sup> )	129 002 011 0202
Female	6-16mm <sup>2</sup>	HMK70-002.1-F (6-16mm <sup>2</sup> )	129 002 021 0201
	14-22mm <sup>2</sup>	HMK70-002.2-F (14-22mm <sup>2</sup> )	129 002 021 0202

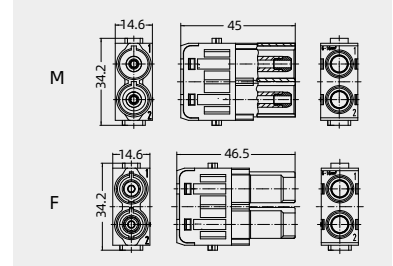

## Accessories

### Tool

hexagonal driver



Description	Designation	Order No.
for axial setscrew with grip	SW-2.5*100	198 001 003 0003

<sup>1)</sup> See P00-12-00-13 for the structural characteristics and description of Axial screw terminal.



# HMK70-002 Crimp Module

1000V 70A

## Inserts



Combination with hinged frame and other modules possible.

## Technical characteristics

Specifications	DIN EN 60 664 DIN EN 61 984		
Approvals			
Inserts	Contacts		
Number of contacts	2	Material	copper alloy
Electrical data acc. to EN 61 984		Surface	hard-silver plated
-Rated current	70A	Contact resistance	≤ 0.5mΩ
-Rated voltage	1000V	Crimp terminal	
-Rated impulse voltage	8kV	- wire gauge	10-25mm <sup>2</sup>
-Pollution degree	3	Max. insulation diameter	11mm
Insulation resistance	≥ 1010Ω	Stripping length	15.5mm
Material	polycarbonate		
Limiting temperatures	-40°C ...+125°C		
Flammability acc. to UL 94	V0		
Mechanical working life			
- mating cycles	≥ 500		

## Crimp terminal

Order crimp contacts separately



Insert	Designation	Order No.
Male	HMK70-002-MC	129 002 010 0201
Female	HMK70-002-FC	129 002 020 0201

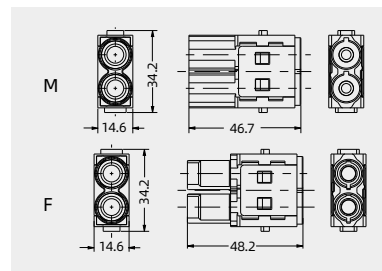

## Crimp contacts

Crimp contacts 70A

Contact resistance ≤ 0.5 mΩ  
silver plated



Male	Order No.	Female	Order No.
CKSM70-6	101 034 110 1301	CKSF70-6	101 034 120 1301
CKSM70-10	101 034 110 1401	CKSF70-10	101 034 120 1401
CKSM70-16	101 034 110 1501	CKSF70-16	101 034 120 1501
CKSM70-25	101 034 110 1601	CKSF70-25	101 034 120 1601

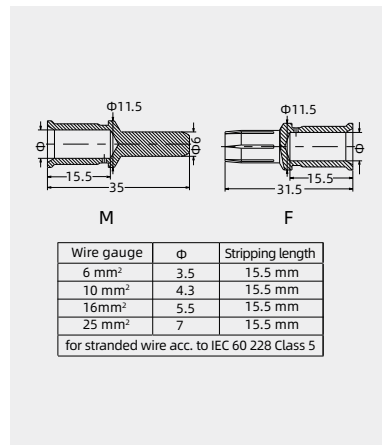

## Tools

Manual hydraulic clamp



Wire gauge	Designation	Order No.
10-240mm <sup>2</sup>	TL05	198 001 001 0005

Remark: for wire gauge 6mm<sup>2</sup>, need to order 2980010010037 TL05 6C die separately.

Notes: The tools for crimp terminal may influence the product quality and stability. Please select the tools recognized by our company.

# HMK-002 Axial module

1000V 40A

Inserts



Combination with hinged frame and other modules possible.

## Technical characteristics

Specifications	DIN EN 60 664 DIN EN 61 984		
Approvals			
Inserts	Contacts		
Number of contacts	2	Material	copper alloy
Electrical data acc. to EN 61 984		Surface	hard-silver plated
-Rated current	40A	Contact resistance	1mΩ
-Rated voltage	1000V	Screw terminal	
-Rated impulse voltage	8kV	- Wire gauge	2.5-10mm <sup>2</sup>
-Pollution degree	3	-AWG	14-8
Rated voltage acc. to UL	600V	-Hexagonal driver	SW 2
Insulation resistance	≥ 10 <sup>10</sup> Ω	- Stripping length	
Material	polycarbonate	-mm <sup>2</sup>	2.5 4 6 10
Limiting temperatures	-40°C ...+125°C	-mm <sup>2</sup>	5 <sup>+1</sup> 5 <sup>+1</sup> 8 <sup>+1</sup> 11 <sup>+1</sup>
Flammability acc. to UL 94	V0	-Tightening torque	
Mechanical working life		-mm <sup>2</sup>	2.5 4 6 10
- mating cycles	≥ 500	-Nm	1.5 1.5 2 2

### Current carrying capacity

The current carrying is limited by maximum temperature of materials for inserts and contacts including terminals

Control and test procedures according to DIN EN 60512-5

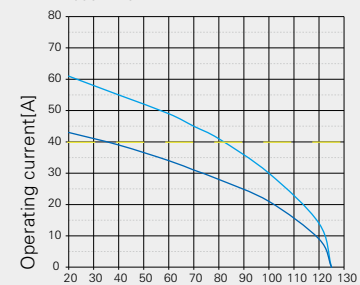

Ambient temperature[°C]

- 24 B hoods/housings with 6 modules, wire gauge: 10mm<sup>2</sup>
- 24 B hoods/housings with 6 modules, wire gauge: 6mm<sup>2</sup>

### Axial screw terminal<sup>1)</sup>



Insert	Wire gauge	Designation	Order No.
Male	2.5-8mm <sup>2</sup>	HMK-002.1-M (2.5-8mm <sup>2</sup> )	129 002 011 0003
	6-10mm <sup>2</sup>	HMK-002.2-M (6-10mm <sup>2</sup> )	129 002 011 0004
Female	2.5-8mm <sup>2</sup>	HMK-002.1-F (2.5-8mm <sup>2</sup> )	129 002 021 0003
	6-10mm <sup>2</sup>	HMK-002.2-F (6-10mm <sup>2</sup> )	129 002 021 0004

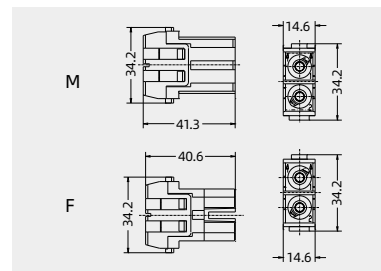

## Accessories

### Tool

hexagonal driver



Description	Designation	Order No.
for axial setscrew with grip	SW-2*100	198 001 003 0002

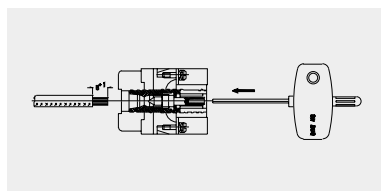

<sup>1)</sup> See P00-12-00-13 for the structural characteristics and description of Axial screw terminal.

# HMK-002 Crimp module

1000V 40A

Inserts



Combination with hinged frame and other modules possible.

## Technical characteristics

Specifications	DIN EN 60 664 DIN EN 61 984		
Approvals			
Inserts		Contacts	
Number of contacts	2	Material	copper alloy
Electrical data acc. to EN 61 984		Surface	hard-silver plated
-Rated current	40A	Contact resistance	≤ 1mΩ
-Rated voltage	1000V	Crimp terminal	
-Rated impulse voltage	8kV	-mm <sup>2</sup>	1.5-10mm <sup>2</sup>
-Pollution degree	3	-AWG	16-8
Insulation resistance	≥ 10 <sup>10</sup> Ω		
Material	polycarbonate		
Limiting temperatures	-40°C ...+125°C		
Flammability acc. to UL 94	V0		
Mechanical working life			
- mating cycles	≥ 500		

### Current carrying capacity

The current carrying is limited by maximum temperature of materials for inserts and contacts including terminals

Control and test procedures according to DIN EN 60512-5

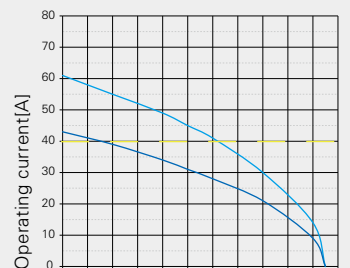

Ambient temperature [°C]

— 24 B hoods/housings with 6 modules, wire gauge: 10mm<sup>2</sup>

— 24 B hoods/housings with 6 modules, wire gauge: 6mm<sup>2</sup>

### Crimp terminal

Order crimp contacts separately



Insert	Designation	Order No.
Male	HMK-002-MC	129 002 010 0001
Female	HMK-002-FC	129 002 020 0001

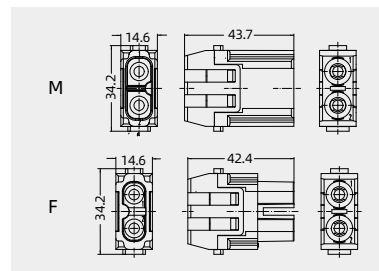

### Crimp contacts

Crimp contacts 40A

Contact resistance ≤ 1 mΩ  
silver plated



Male	Order No.	Female	Order No.
CCSM-1.5	101 023 110 0901	CCSF-1.5	101 023 120 0901
CCSM-2.5	101 023 110 1001	CCSF-2.5	101 023 120 1001
CCSM-4.0	101 023 110 1201	CCSF-4.0	101 023 120 1201
CCSM-6.0	101 023 110 1301	CCSF-6.0	101 023 120 1301
CCSM-10.0	101 023 110 1401	CCSF-10.0	101 023 120 1401

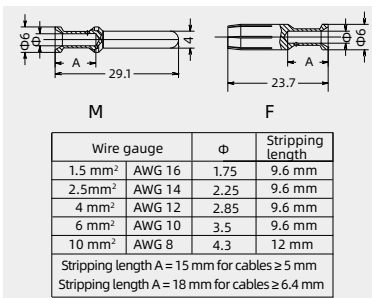

### Tools

Crimping tool



Contact removal tool



Wire gauge	Designation	Order No.
1.5-6mm <sup>2</sup>	TL02-0G	198 001 001 0012
4/6/10mm <sup>2</sup>	TL02-3G	198 001 001 0013

Application	Designation	Order No.
for crimp contacts 40A	TL06G	198 001 000 0009

Notes: The tools for crimp terminal may influence the product quality and stability. Please select the tools recognized by our company.

# HMK-003 Axial module

690V 40A

Inserts



Combination with hinged frame and other modules possible.

## Technical characteristics

Specifications	DIN EN 60 664 DIN EN 61 984	
Approvals		
Inserts	Contacts	
Number of contacts	3	Material: copper alloy
Electrical data acc. to EN 61 984		Surface: hard-silver plated
-Rated current	40A	Contact resistance: 1mΩ
-Rated voltage	690V	Screw terminal
-Rated impulse voltage	8kV	- Wire gauge: 2.5-10mm <sup>2</sup>
-Pollution degree	3	-AWG: 14-8
Rated voltage acc. to UL	600V	-Hexagonal driver: SW 2
Insulation resistance	≥ 10 <sup>10</sup> Ω	- Stripping length
Material	polycarbonate	-mm <sup>2</sup> : 2.5 4 6 10
Limiting temperatures	-40°C ...+125°C	-mm <sup>2</sup> : 5 <sup>+1</sup> 5 <sup>+1</sup> 8 <sup>+1</sup> 11 <sup>+1</sup>
Flammability acc. to UL 94	V0	-Tightening torque
Mechanical working life		-mm <sup>2</sup> : 2.5 4 6 10
- mating cycles	≥ 500	-Nm: 1.5 1.5 2 2

### Current carrying capacity

The current carrying is limited by maximum temperature of materials for inserts and contacts including terminals

Control and test procedures according to DIN EN 60512-5

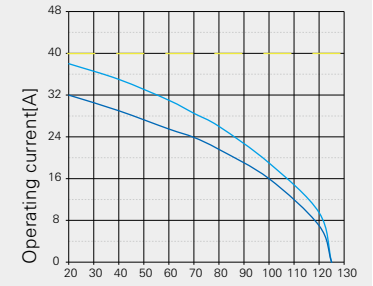

Ambient temperature [°C]

— 24 B hoods/housings with 6 modules, wire gauge: 6mm<sup>2</sup>

— 24 B hoods/housings with 6 modules, wire gauge: 4mm<sup>2</sup>

### Axial screw terminal<sup>1)</sup>



Insert	Wire gauge	Designation	Order No.
Male	2.5-8mm <sup>2</sup>	HMK-003.1-M (2.5-8mm <sup>2</sup> )	129 003 011 0001
	6-10mm <sup>2</sup>	HMK-003.2-M (6-10mm <sup>2</sup> )	129 003 011 0002
Female	2.5-8mm <sup>2</sup>	HMK-003.1-F (2.5-8mm <sup>2</sup> )	129 003 021 0001
	6-10mm <sup>2</sup>	HMK-003.2-F (6-10mm <sup>2</sup> )	129 003 021 0002

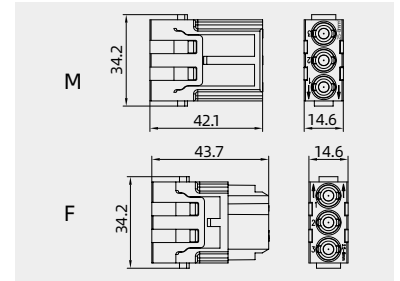

## Accessories

### Tool

hexagonal driver



Description	Designation	Order No.
for axial setscrew with grip	SW-2*100	198 001 003 0002

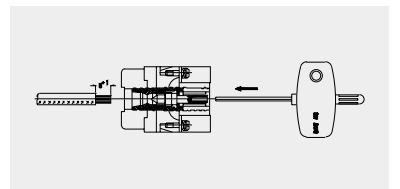

<sup>1)</sup> See P00-12-00-13 for the structural characteristics and description of Axial screw terminal.

# HMK-003 Crimp module

500V 40A

Inserts



Combination with hinged frame and other modules possible.

## Technical characteristics

Specifications	DIN EN 60 664 DIN EN 61 984		
Approvals			
Inserts		Contacts	
Number of contacts	3	Material	copper alloy
Electrical data acc. to EN 61 984		Surface	hard-silver plated
Cable diameter up to 7.5 mm		Contact resistance	≤ 1mΩ
-Rated current	40A	Crimp terminal	
-Rated voltage	500V	-mm <sup>2</sup>	1.5-10mm <sup>2</sup>
-Rated impulse voltage	6kV	-AWG	16-8
-Pollution degree	3		
Rated voltage acc. to UL	600V		
Rated current acc. to UL	32A		
Insulation resistance	≥ 10 <sup>10</sup> Ω		
Material	polycarbonate		
Limiting temperatures	-40°C ...+125°C		
Flammability acc. to UL 94	V0		
Mechanical working life			
- mating cycles	≥ 500		

### Current carrying capacity

The current carrying is limited by maximum temperature of materials for inserts and contacts including terminals

Control and test procedures according to DIN EN 60512-5

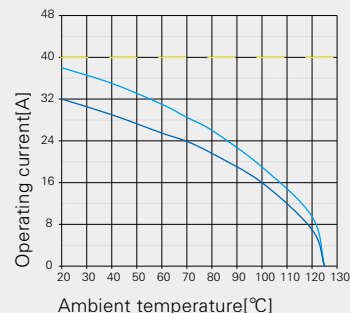

— 24 B hoods/housings with 6 modules, wire gauge: 6mm<sup>2</sup>  
 — 24 B hoods/housings with 6 modules, wire gauge: 4mm<sup>2</sup>

### Crimp terminal

Order crimp contacts separately



Insert	Designation	Order No.
Male	HMK-003-MC	129 003 010 0001
Female	HMK-003-FC	129 003 020 0001

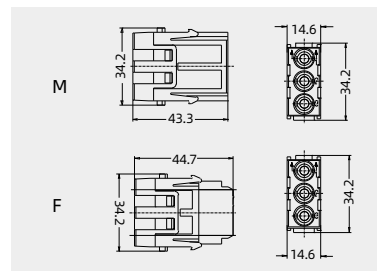

### Crimp contacts

Crimp contacts 40A

Contact resistance ≤ 1 mΩ  
silver plated



Male	Order No.	Female	Order No.
CCSM-1.5	101 023 110 0901	CCSF-1.5	101 023 120 0901
CCSM-2.5	101 023 110 1001	CCSF-2.5	101 023 120 1001
CCSM-4.0	101 023 110 1201	CCSF-4.0	101 023 120 1201
CCSM-6.0	101 023 110 1301	CCSF-6.0	101 023 120 1301
CCSM-10.0	101 023 110 1401	CCSF-10.0	101 023 120 1401

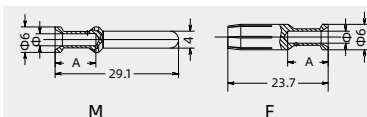

Wire gauge	Φ	Stripping length
1.5 mm <sup>2</sup>	AWG 16	1.75
2.5mm <sup>2</sup>	AWG 14	2.25
4 mm <sup>2</sup>	AWG 12	2.85
6 mm <sup>2</sup>	AWG 10	3.5
10 mm <sup>2</sup>	AWG 8	4.3

Stripping length A = 15 mm for cables ≥ 5 mm  
 Stripping length A = 18 mm for cables ≥ 6.4 mm

### Tools

Crimping tool



Contact removal tool



Wire gauge	Designation	Order No.
1.5-6mm <sup>2</sup>	TL02-0G	198 001 001 0012
4/6/10mm <sup>2</sup>	TL02-3G	198 001 001 0013
Application	Designation	Order No.
for crimp contacts 40A	TL06G	198 001 000 0009

Notes: The tools for crimp terminal may influence the product quality and stability. Please select the tools recognized by our company.

# HMK-003 Crimp module

690V 40A

Inserts



Combination with hinged frame and other modules possible.

## Technical characteristics

Specifications	DIN EN 60 664 DIN EN 61 984		
Approvals			
Inserts		Contacts	
Number of contacts	3	Material	copper alloy
Electrical data acc. to EN 61 984		Surface	hard-silver plated
Cable diameter up to 7.5 mm		Contact resistance	≤ 1mΩ
-Rated current	40A	Crimp terminal	
-Rated voltage	690V	-mm <sup>2</sup>	1.5-6mm <sup>2</sup>
-Rated impulse voltage	8kV	-AWG	16-10
-Pollution degree	3		
Rated voltage acc. to UL	600V		
Rated current acc. to UL	40A		
Insulation resistance	≥ 10 <sup>10</sup> Ω		
Material	polycarbonate		
Limiting temperatures	-40°C ...+125°C		
Flammability acc. to UL 94	V0		
Mechanical working life			
- mating cycles	≥ 500		

### Crimp terminal

Order crimp contacts separately



Insert	Designation	Order No.
Male	HMK-003-MC-V2	129 003 010 0504
Female	HMK-003-FC-V2	129 003 020 0504

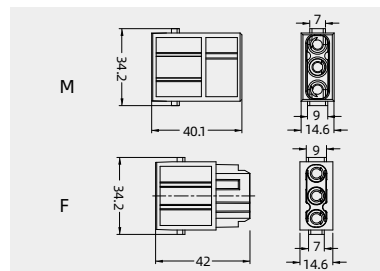
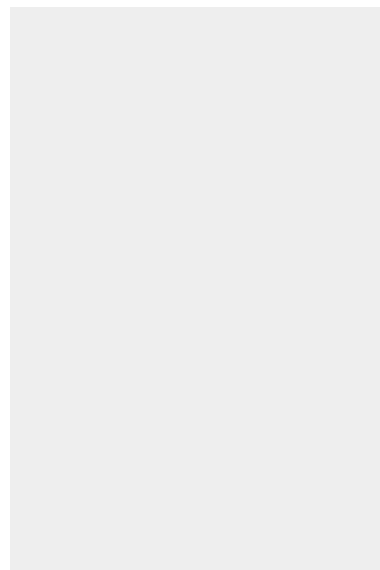

## Crimp contacts

Crimp contacts 40A

Contact resistance ≤ 1 mΩ  
silver plated



Male	Order No.	Female	Order No.
CCSM-1.5	101 023 110 0901	CCSF-1.5	101 023 120 0901
CCSM-2.5	101 023 110 1001	CCSF-2.5	101 023 120 1001
CCSM-4.0	101 023 110 1201	CCSF-4.0	101 023 120 1201
CCSM-6.0	101 023 110 1301	CCSF-6.0	101 023 120 1301
CCSM-10.0	101 023 110 1401	CCSF-10.0	101 023 120 1401

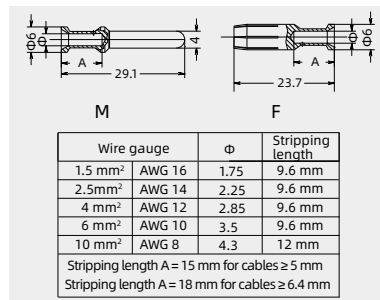

### Tools

Crimping tool



Contact removal tool



Wire gauge	Designation	Order No.
1.5-6mm <sup>2</sup>	TL02-0G	198 001 001 0012
4/6/10mm <sup>2</sup>	TL02-3G	198 001 001 0013

Application	Designation	Order No.
for crimp contacts 40A	TL06G	198 001 000 0009

Notes: The tools for crimp terminal may influence the product quality and stability.  
Please select the tools recognized by our company.

# HMK-003 Cage-clamp module

830V 40A

## Inserts



Combination with hinged frame and other modules possible.

## Technical characteristics

Specifications	DIN EN 60 664 DIN EN 61 984
----------------	--------------------------------

Inserts		Contacts	
Number of contacts	3	Material	copper alloy
Electrical data acc. to EN 61 984		Surface	hard-silver plated
-Rated current	40A	Cage clamp module	
-Rated voltage	690V	-mm <sup>2</sup>	1.5-6mm <sup>2</sup>
-Rated impulse voltage	8kV	-AWG	16-10
-Pollution degree	3		
Rated voltage acc. to UL	600V		
Insulation resistance	≥ 10 <sup>10</sup> Ω		
Material	polycarbonate		
Limiting temperatures	-40°C ...+125°C		
Flammability acc. to UL 94	V0		
Mechanical working life			
- mating cycles	≥ 500		

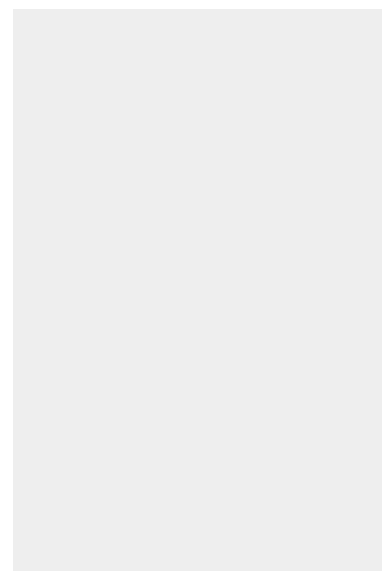

## Cage clamp module (Quick-in)



Insert	Designation	Order No.
Male	HMK-003-MQ	129 003 010 0507
Female	HMK-003-FQ	129 003 020 0507

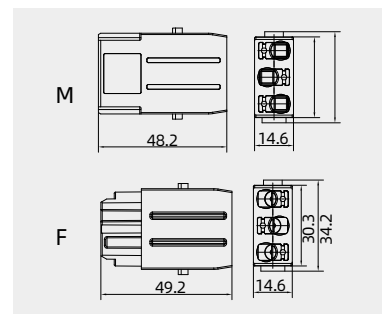

# HMK-003/4 Crimp module

830/830V 40/10A

## Inserts



Combination with hinged frame and other modules possible.

## Technical characteristics

Specifications	DIN EN 60 664 DIN EN 61 984		
Approvals			
Inserts		Contacts	
Number of contacts	3/4	Material	copper alloy
Electrical data acc. to EN 61 984		Surface	hard-silver plated hard-gold plated
Power contacts		Contact resistance	
-Rated current	40A	-Power contacts	≤ 1mΩ
-Rated voltage	830V	-Signal contacts	≤ 3mΩ
-Rated impulse voltage	8kV	Crimp terminal	
-Pollution degree	3	- mm <sup>2</sup>	
Signal contacts		-Power contacts	1.5-6mm <sup>2</sup>
-Rated current	10A	-Signal contacts	0.14-2.5mm <sup>2</sup>
-Rated voltage	830V	- AWG	
-Rated impulse voltage	8kV	-Power contacts	16-10
-Pollution degree	3	-Signal contacts	26-14
Rated voltage acc. to UL	600V	Max. insulation diameter	
Insulation resistance	≥ 10 <sup>10</sup> Ω	- Power contacts	5mm
Material	polycarbonate		
Limiting temperatures	-40°C ...+125°C		
Flammability acc. to UL 94	V0		
Mechanical working life	≥ 500		

### Current carrying capacity

The current carrying is limited by maximum temperature of materials for inserts and contacts including terminals  
Control and test procedures according to DIN EN 60512-5

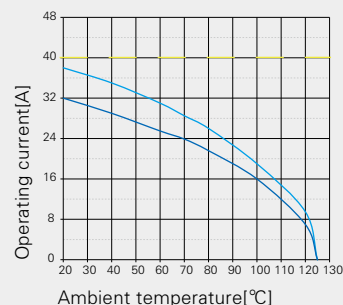

— 24 B hoods/housings with 6 modules, wire gauge: 6mm<sup>2</sup>  
— 24 B hoods/housings with 6 modules, wire gauge: 4mm<sup>2</sup>

### Crimp terminal

Order crimp contacts separately



Insert	Designation	Order No.
Male	HMK-003/4-MC	129 007 010 0001
Female	HMK-003/4-FC	129 007 020 0001

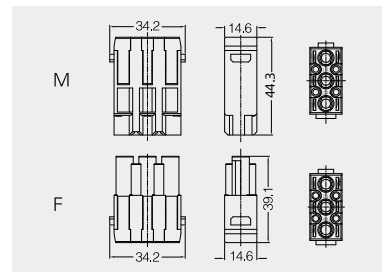

## Crimp contacts

### Crimp contacts 40A/10A

Contact resistance ≤ 1 mΩ silver plated



Male	Order No.	Female	Order No.
CCSM-1.5	101 023 110 0901	CCSF-1.5	101 023 120 0901
CCSM-2.5	101 023 110 1001	CCSF-2.5	101 023 120 1001
CCSM-4.0	101 023 110 1201	CCSF-4.0	101 023 120 1201
CCSM-6.0	101 023 110 1301	CCSF-6.0	101 023 120 1301
CCSM-10.0	101 023 110 1401	CCSF-10.0	101 023 120 1401

Contact resistance ≤ 3 mΩ silver plated



	Order No.		Order No.
CDSM-0.25	101 017 110 0101	CDSF-0.25	101 017 120 0101
CDSM-0.37	101 017 110 0301	CDSF-0.37	101 017 120 0301
CDSM-0.50	101 017 110 0401	CDSF-0.50	101 017 120 0401
CDSM-0.75	101 017 110 0601	CDSF-0.75	101 017 120 0601
CDSM-1.0	101 017 110 0801	CDSF-1.0	101 017 120 0801
CDSM-1.5	101 017 110 0901	CDSF-1.5	101 017 120 0901
CDSM-2.5	101 017 110 1001	CDSF-2.5	101 017 120 1001

Contact resistance ≤ 3mΩ gold plated



	Order No.		Order No.
CDGM-0.25	101 017 210 0101	CDGF-0.25	101 017 220 0101
CDGM-0.37	101 017 210 0301	CDGF-0.37	101 017 220 0301
CDGM-0.50	101 017 210 0401	CDGF-0.50	101 017 220 0401
CDGM-0.75	101 017 210 0601	CDGF-0.75	101 017 220 0601
CDGM-1.0	101 017 210 0801	CDGF-1.0	101 017 220 0801
CDGM-1.5	101 017 210 0901	CDGF-1.5	101 017 220 0901
CDGM-2.5	101 017 210 1001	CDGF-2.5	101 017 220 1001

More crimp contacts 10A see P13-02,P13-03.

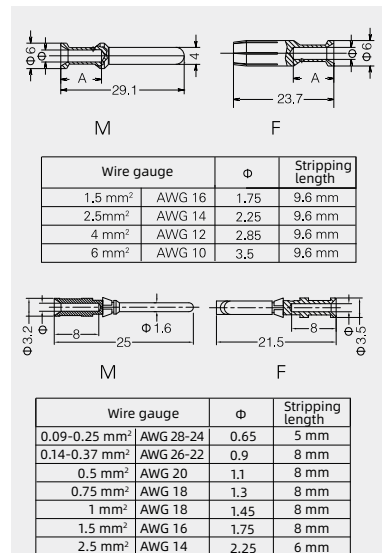

When the wire gauge is less than 0.75mm<sup>2</sup>, it's better to use the auxiliary pin assembly tool TL16.

Notes: The tools for crimp terminal may influence the product quality and stability. Please select the tools recognized by our company.  
\*Please find the details of crimp contact tools on page 32-02~32-05.



# HMK-004 Crimp module

830V 40A

Inserts



Combination with hinged frame and other modules possible.

## Technical characteristics

Specifications	DIN EN 60 664 DIN EN 61 984		
Approvals			
Inserts		Contacts	
Number of contacts	4	Material	copper alloy
Electrical data acc. to EN 61 984		Surface	hard-silver plated
Rated current	40A	Contact resistance	≤ 1mΩ
Rated voltage	830V	Crimp terminal	
Rated impulse voltage	8kV	-mm <sup>2</sup>	1.5-6mm <sup>2</sup>
Pollution degree	3	-AWG	16-10
Rated voltage acc. to UL	600V		
Insulation resistance	≥ 10 <sup>10</sup> Ω		
Material	polycarbonate		
Limiting temperatures	-40°C ...+125°C		
Flammability acc. to UL 94	V0		
Mechanical working life			
- mating cycles	≥ 500		

### Current carrying capacity

The current carrying is limited by maximum temperature of materials for inserts and contacts including terminals

Control and test procedures according to DIN EN 60512-5

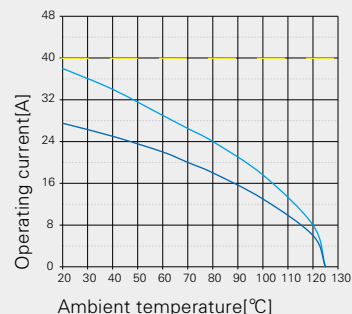

— 24 B hoods/housings with 6 modules, wire gauge: 6mm<sup>2</sup>  
— 24 B hoods/housings with 6 modules, wire gauge: 4mm<sup>2</sup>

### Crimp terminal

Order crimp contacts separately



Insert	Designation	Order No.
Male	HMK-004-MC	129 004 010 0001
Female	HMK-004-FC	129 004 020 0001

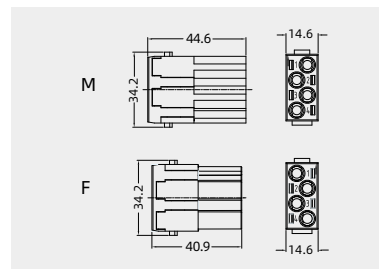

## Crimp contacts

### Crimp contacts 40A

Contact resistance ≤ 1 mΩ  
silver plated



Male	Order No.	Female	Order No.
CCSM-1.5	101 023 110 0901	CCSF-1.5	101 023 120 0901
CCSM-2.5	101 023 110 1001	CCSF-2.5	101 023 120 1001
CCSM-4.0	101 023 110 1201	CCSF-4.0	101 023 120 1201
CCSM-6.0	101 023 110 1301	CCSF-6.0	101 023 120 1301

Wire gauge		Φ	Stripping length
1.5 mm <sup>2</sup>	AWG 16	1.75	9.6 mm
2.5mm <sup>2</sup>	AWG 14	2.25	9.6 mm
4 mm <sup>2</sup>	AWG 12	2.85	9.6 mm
6 mm <sup>2</sup>	AWG 10	3.5	9.6 mm

Stripping length A = 15 mm for cables ≥ 5 mm  
Stripping length A = 18 mm for cables ≥ 6.4 mm

### Tools

#### Crimping tool



#### Contact removal tool



Wire gauge	Designation	Order No.
1.5-6mm <sup>2</sup>	TL02-0G	198 001 001 0012
4/6/10mm <sup>2</sup>	TL02-3G	198 001 001 0013

Application	Designation	Order No.
for crimp contacts 40A	TL06G	198 001 000 0009

Notes: The tools for crimp terminal may influence the product quality and stability. Please select the tools recognized by our company.

# HMK-004 Cage-clamp module

830V 40A

## Inserts



Combination with hinged frame and other modules possible.

## Technical characteristics

Specifications	DIN EN 60 664 DIN EN 61 984
----------------	--------------------------------

Inserts		Contacts	
Number of contacts	4	Material	copper alloy
Electrical data acc. to EN 61 984		Surface	hard-silver plated
Rated current	40A	Contact resistance	≤ 3mΩ
Rated voltage	830V	Spring terminal(Quick-in)	
Rated impulse voltage	8kV	-mm <sup>2</sup>	1.5-6mm <sup>2</sup>
Pollution degree	3	-AWG	16-10
Rated voltage acc. to UL	600V		
Insulation resistance	≥ 10 <sup>10</sup> Ω		
Material	polycarbonate		
Limiting temperatures	-40°C ...+125°C		
Flammability acc. to UL 94	V0		
Mechanical working life			
- mating cycles	≥ 500		



## Spring terminal(Quick-in)



Insert	Designation	Order No.
Male	HMK-004-MQ	129 004 010 0506
Female	HMK-004-FQ	129 004 020 0506

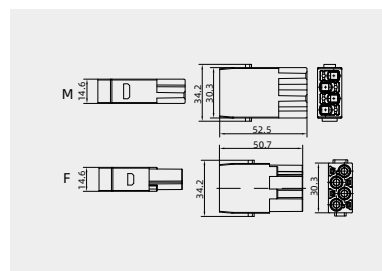
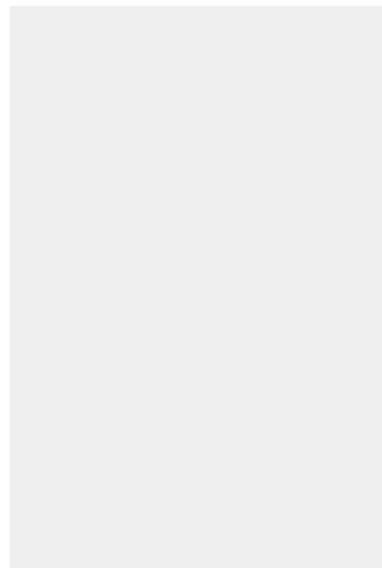

# H2MVC-002 High voltage module

2900/5000V 40A

## Inserts



Combination with hinged frame and other modules possible.  
Only suitable for high structure shells.

## Technical characteristics

Specifications	DIN EN 60 664 DIN EN 61 984		
Approvals			
Inserts		Contacts	
Number of contacts	2	Material	copper alloy
Electrical dataacc. to EN 61 984		Surface	hard-silver plated
-Rated current	40A	Contact resistance	≤ 1mΩ
-Rated voltage conductor(ground)	2900V	Crimp terminal	
-Rated voltage conductor(conductor)	5000V	-mm <sup>2</sup>	1.5-10mm <sup>2</sup>
-Rated impulse voltage	15kV	-AWG	16-8
-Pollution degree	3		
Insulation resistance	≥ 10 <sup>10</sup> Ω	Assembly instructions	
Material	polycarbonate/ PTFE		
Limiting temperatures	-40°C ...+125°C		Crimp with crimping tool Snap crimped cable in the insert
Flammability acc. to UL 94	V0		shrink the heat shrink tube over the rear of contact
Max. cable diameter	9mm		
Mechanical working life			
- mating cycles	≥ 500		

### Current carrying capacity

The current carrying is limited by maximum temperature of materials for inserts and contacts including terminals

Control and test procedures according to DIN EN 60512-5

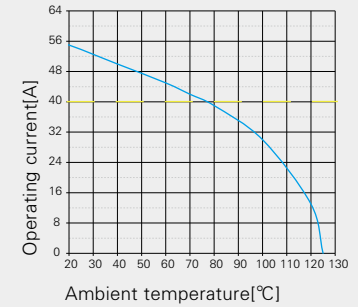

— 24 B hoods/housings with 3 modules,  
wire gauge: 6mm<sup>2</sup>

### Crimp terminal

Order crimp contacts separately



Insert	Designation	Order No.
Male	H2MVC-002-MC	129 002 010 0401
Female	H2MVC-002-FC	129 002 020 0401

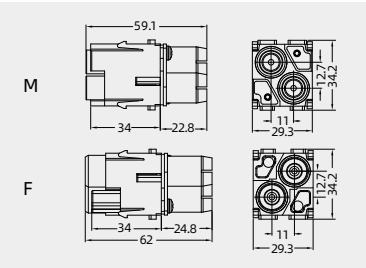

## Crimp contacts

Crimp contacts 40A

Contact resistance ≤ 1 mΩ  
silver plated



Male	Order No.	Female	Order No.
CCSM-1.5	101 023 110 0901	CCSF-1.5	101 023 120 0901
CCSM-2.5	101 023 110 1001	CCSF-2.5	101 023 120 1001
CCSM-4.0	101 023 110 1201	CCSF-4.0	101 023 120 1201
CCSM-6.0	101 023 110 1301	CCSF-6.0	101 023 120 1301
CCSM-10.0	101 023 110 1401	CCSF-10.0	101 023 120 1401

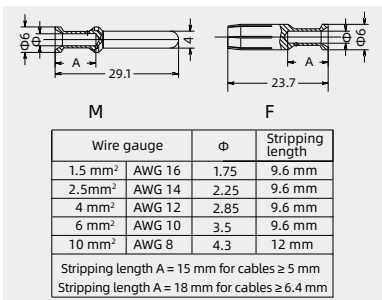

### Tools

Crimping tool



Contact removal tool



Wire gauge	Designation	Order No.
1.5-6mm <sup>2</sup>	TL02-0G	198 001 001 0012
4/6/10mm <sup>2</sup>	TL02-3G	198 001 001 0013

Application	Designation	Order No.
for locking sleeve	TL10	198 001 000 0014

Notes: The tools for crimp terminal may influence the product quality and stability.  
Please select the tools recognized by our company.

## H2MVE-002 High voltage module

2900/5000V 16A

### Inserts



Combination with hinged frame and other modules possible.  
Only suitable for high structure shells.

### Technical characteristics

Specifications	DIN EN 60 664 DIN EN 61 984		
Approvals			
Inserts		Contacts	
Number of contacts	2	Material	copper alloy
Electrical data acc. to EN 61 984		Surface	- hard-silver plated - hard-gold plated
-Rated current	16A	Contact resistance	≤ 1mΩ
-Rated voltage conductor(ground)	2900V	Crimp terminal	
-Rated voltage conductor(conductor)	5000V	-mm <sup>2</sup>	0.5-4mm <sup>2</sup>
-Rated impulse voltage	15kV	-AWG	20-12
-Pollution degree	3		
Insulation resistance	≥ 10 <sup>10</sup> Ω	Assembly instructions	
Material	polycarbonate/PTFE		
Limiting temperatures	-40°C ...+125°C		
Flammability acc. to UL 94	V0		
Mechanical working life			
Mechanical working life	≥ 500		

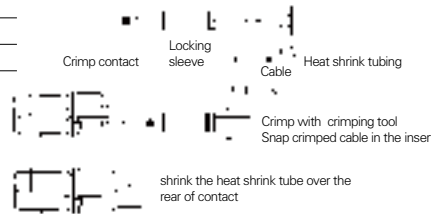

### Current carrying capacity

The current carrying is limited by maximum temperature of materials for inserts and contacts including terminals

Control and test procedures according to DIN EN 60512-5

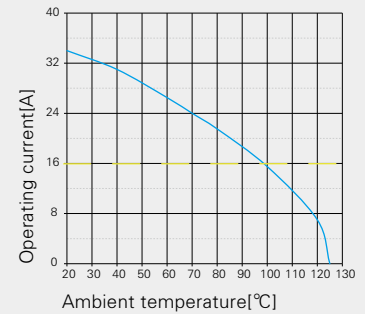

— 16 B hoods/housings with 1 modules,  
wire gauge: 2.5mm<sup>2</sup>

### Crimp terminal

Order crimp contacts separately



Insert	Designation	Order No.
Male	H2MVE-002-MC	129 002 010 0301
Female	H2MVE-002-FC	129 002 020 0301

### Crimp contacts

#### Crimp contacts 16A

Contact resistance ≤ 1mΩ  
silver plated



gold plated



More crimp contacts 16A see P13-04.

#### Tools

##### Crimping tool



Male	Order No.	Female	Order No.
CESM-0.50	101 019 110 0401	CESF-0.50	101 019 120 0401
CESM-0.75	101 019 110 0601	CESF-0.75	101 019 120 0601
CESM-1.0	101 019 110 0801	CESF-1.0	101 019 120 0801
CESM-1.5	101 019 110 0901	CESF-1.5	101 019 120 0901
CESM-2.5	101 019 110 1001	CESF-2.5	101 019 120 1001
CESM-3.0	101 019 110 1101	CESF-3.0	101 019 120 1101
CESM-4.0	101 019 110 1201	CESF-4.0	101 019 120 1201
CEGM-0.50	101 019 210 0401	CEGF-0.50	101 019 220 0401
CEGM-0.75	101 019 210 0601	CEGF-0.75	101 019 220 0601
CEGM-1.0	101 019 210 0801	CEGF-1.0	101 019 220 0801
CEGM-1.5	101 019 210 0901	CEGF-1.5	101 019 220 0901
CEGM-2.5	101 019 210 1001	CEGF-2.5	101 019 220 1001
CEGM-3.0	101 019 210 1101	CEGF-3.0	101 019 220 1101
CEGM-4.0	101 019 210 1201	CEGF-4.0	101 019 220 1201

Wire gauge	Designation	Order No.
0.14-4mm <sup>2</sup>	TL02G	198 001 001 0011
Application	Designation	Order No.
for locking sleeve	TL10	198 001 000 0014

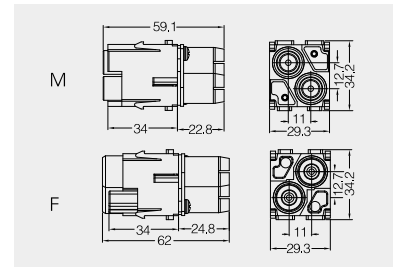

Identification	Wire gauge	Stripping length
no groove	0.5 mm <sup>2</sup> AWG 20	7.5mm
1 groove	0.75 mm <sup>2</sup> AWG 18	7.5mm
1 groove	1 mm <sup>2</sup> AWG 18	7.5mm
2 grooves	1.5 mm <sup>2</sup> AWG 16	7.5mm
3 grooves	2.5 mm <sup>2</sup> AWG 14	7.5mm
wide groove	3 mm <sup>2</sup> AWG 12	7.5mm
no groove	4 mm <sup>2</sup> AWG 12	7.5mm

When the wire gauge is less than 0.75mm<sup>2</sup>, it's better to use the auxiliary pin assembly tool TL15.

Notes: The tools for crimp terminal may influence the product quality and stability. Please select the tools recognized by our company.

# HME-005 Screw module

230/400V 16A

## Inserts



Combination with hinged frame and other modules possible.

## Technical characteristics

Specifications	DIN EN 60 664 DIN EN 61 984		
Approvals			
Inserts		Contacts	
Number of contacts	5	Material	copper alloy
Electrical data acc. to IEC 61984		Surface	hard-silver plated
Rated current	16A	Contact resistance	≤ 1mΩ
Rated voltage conductor -ground	230V	Screw terminal	
Rated voltage conductor - conductor	400V	-mm <sup>2</sup>	0.5-4mm <sup>2</sup>
Rated impulse voltage	4kV	-AWG	20-14
Pollution degree	3		
Insulation resistance	≥ 10 <sup>10</sup> Ω		
Material	polycarbonate		
Limiting temperatures	-40°C ...+125°C		
Flammability acc. to UL 94	V0		
Mechanical working life			
- mating cycles	≥ 500		

### Current carrying capacity

The current carrying is limited by maximum temperature of materials for inserts and contacts including terminals

Control and test procedures according to DIN EN 60512-5

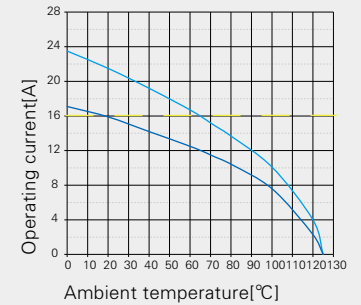

- 24 B hoods/housings with 6 modules, wire gauge: 2.5mm<sup>2</sup>
- 24 B hoods/housings with 6 modules, wire gauge: 1.5mm<sup>2</sup>

## Screw terminal

Insert	Designation	Order No.
Male	HME-005-M	129 005 011 0001
Female	HME-005-F	129 005 021 0001

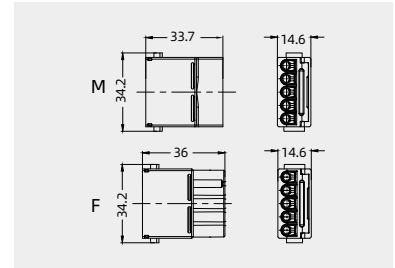

## Assembly instructions

Step 1: remove the cover.

Step 2: install the wire from the top and fasten the side screw.

Step 3: put the cover on.



## HME-005 Cage-clamp module

400V 16A

Inserts



Combination with hinged frame and other modules possible.

## Technical characteristics

Specifications	DIN EN 60 664 DIN EN 61 984		
Approvals			
Inserts	Contacts		
Number of contacts	5	Material	copper alloy
Electrical data acc. to EN 61 984		Surface	hard-silver plated
-Rated current	16A	Contact resistance	$\leq 3m\Omega$
-Rated voltage	400V	Spring terminal	
-Rated impulse voltage	6kV	-mm <sup>2</sup>	0.14-2.5mm <sup>2</sup>
-Pollution degree	3	-AWG	26-14
Rated voltage acc. to UL	600V		
Insulation resistance	$\geq 10^{10}\Omega$		
Material	polycarbonate		
Limiting temperatures	-40°C ... +125°C		
Flammability acc. to UL 94	V0		
Mechanical working life			
- mating cycles	$\geq 500$		

## Current carrying capacity

The current carrying is limited by maximum temperature of materials for inserts and contacts including terminals

Control and test procedures according to DIN EN 60512-5

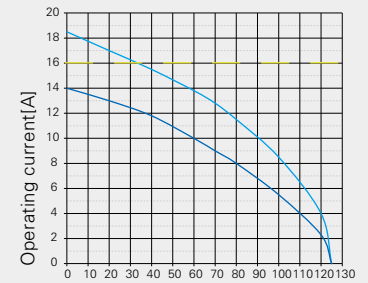

Ambient temperature[°C]

- 24 B hoods/housings with 6 modules, wire gauge: 2.5mm<sup>2</sup>
- 24 B hoods/housings with 6 modules, wire gauge: 1.5mm<sup>2</sup>

## Cage-clamp terminal

See P00-14 for the structural characteristics of spring.



Insert	Designation	Order No.
Male	HME-005-MS	129 005 012 0001
Female	HME-005-FS	129 005 022 0001

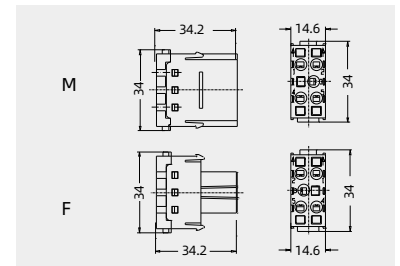

# HME-006 Crimp module

500V 16A

## Inserts



Combination with hinged frame and other modules possible.

## Technical characteristics

Specifications	DIN EN 60 664 DIN EN 61 984		
Approvals			
Inserts		Contacts	
Number of contacts	6	Material	copper alloy
Electrical data acc. to EN 61 984		Surface	hard-silver plated hard-gold plated
Rated current	16A	Contact resistance	≤ 1mΩ
Rated voltage	500V	Crimp terminal	
Rated impulse voltage	6kV	-mm <sup>2</sup>	0.14-4mm <sup>2</sup>
Pollution degree	3	-AWG	26-12
Rated voltage acc. to UL	600V		
Insulation resistance	≥ 10 <sup>10</sup> Ω		
Material	polycarbonate		
Limiting temperatures	-40°C ...+125°C		
Flammability acc. to UL 94	V0		
Mechanical working life			
- mating cycles	≥ 500		

### Current carrying capacity

The current carrying is limited by maximum temperature of materials for inserts and contacts including terminals

Control and test procedures according to DIN EN 60512-5

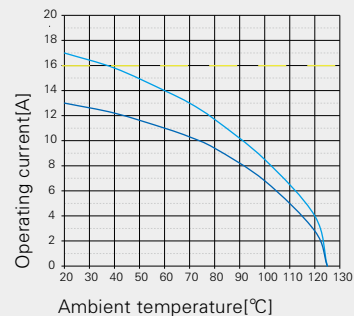

— 24 B hoods/housings with 6 modules, wire gauge: 2.5mm<sup>2</sup>  
- - 24 B hoods/housings with 6 modules, wire gauge: 1.5mm<sup>2</sup>

## Crimp terminal

Order crimp contacts separately



Insert	Designation	Order No.
Male	HME-006-MC	129 006 010 0001
Female	HME-006-FC	129 006 020 0001

## Crimp contacts

### Crimp contacts 16A

Contact resistance ≤ 1mΩ silver plated



gold plated



Male	Order No.	Female	Order No.
CESM-0.37	101 019 110 0301	CESF-0.37	101 019 120 0301
CESM-0.50	101 019 110 0401	CESF-0.50	101 019 120 0401
CESM-0.75	101 019 110 0601	CESF-0.75	101 019 120 0601
CESM-1.0	101 019 110 0801	CESF-1.0	101 019 120 0801
CESM-1.5	101 019 110 0901	CESF-1.5	101 019 120 0901
CESM-2.5	101 019 110 1001	CESF-2.5	101 019 120 1001
CESM-3.0	101 019 110 1101	CESF-3.0	101 019 120 1101
CESM-4.0	101 019 110 1201	CESF-4.0	101 019 120 1201
CEGM-0.37	101 019 210 0301	CEGF-0.37	101 019 220 0301
CEGM-0.50	101 019 210 0401	CEGF-0.50	101 019 220 0401
CEGM-0.75	101 019 210 0601	CEGF-0.75	101 019 220 0601
CEGM-1.0	101 019 210 0801	CEGF-1.0	101 019 220 0801
CEGM-1.5	101 019 210 0901	CEGF-1.5	101 019 220 0901
CEGM-2.5	101 019 210 1001	CEGF-2.5	101 019 220 1001
CEGM-3.0	101 019 210 1101	CEGF-3.0	101 019 220 1101
CEGM-4.0	101 019 210 1201	CEGF-4.0	101 019 220 1201

More crimp contacts 16A see P13-04.

## Tools

### Crimping tool



### Contact removal tool



Wire gauge	Designation	Order No.
0.14-4mm <sup>2</sup>	TL02G	198 001 001 0011
Wire gauge: 0.14-0.37mm <sup>2</sup> please select TL02 Crimping tool.		
Application	Designation	Order No.
for crimp contacts 16A	TL01	198 001 000 0002

Notes: The tools for crimp terminal may influence the product quality and stability. Please select the tools recognized by our company.

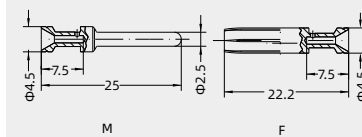

Identification	Wire gauge	Stripping length
no groove	0.14-0.37 mm <sup>2</sup>   AWG 26-22	7.5mm
no groove	0.5 mm <sup>2</sup>   AWG 20	7.5mm
1 groove	0.75 mm <sup>2</sup>   AWG 18	7.5mm
1 groove	1 mm <sup>2</sup>   AWG 18	7.5mm
2 grooves	1.5 mm <sup>2</sup>   AWG 16	7.5mm
3 grooves	2.5 mm <sup>2</sup>   AWG 14	7.5mm
wide groove	3 mm <sup>2</sup>   AWG 12	7.5mm
no groove	4 mm <sup>2</sup>   AWG 12	7.5mm

When the wire gauge is less than 0.75mm<sup>2</sup>, it's better to use the auxiliary pin assembly tool TL15.

# HME-006 Quick-in module

500V 16A

## Inserts



Combination with hinged frame and other modules possible.

## Technical characteristics

Specifications	DIN EN 60 664 DIN EN 61 984		
Approvals			
Inserts		Contacts	
No. of contact	6	Terminal	spring terminal(Quick-in)
Electrical data acc. to EN 61 984		Material	copper alloy
-Rated current	16A	Surface	hard-silver plated
-Rated voltage	500V	Contact resistance	≤ 3mΩ
-Rated impulse voltage	6kV	Wire gauge	
-Pollution degree	3	-mm <sup>2</sup>	0.5-4.0mm <sup>2</sup>
Insulation resistance	≥ 10 <sup>10</sup> Ω	-AWG	20-12
Material	polycarbonate	(For wires with crimped ferrule, wire gauge)	
Colour	RAL 7032(light grey)	-mm <sup>2</sup>	0.14-2.5mm <sup>2</sup>
Limiting temperatures	-40°C ...+125°C	-AWG	26-14
Flammability acc. to UL 94	V0	Stripping length	10±0.5mm
Mating cycles	≥ 500		

## Spring terminal(Quick-in)



Insert	Designation	Order No.
Male	HME-006-MQ	129 006 010 0002
Female	HME-006-FQ	129 006 020 0002

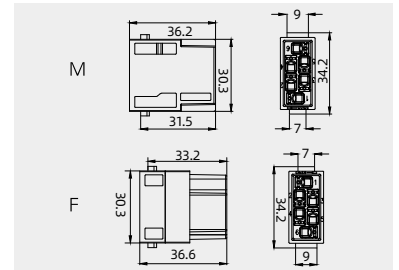
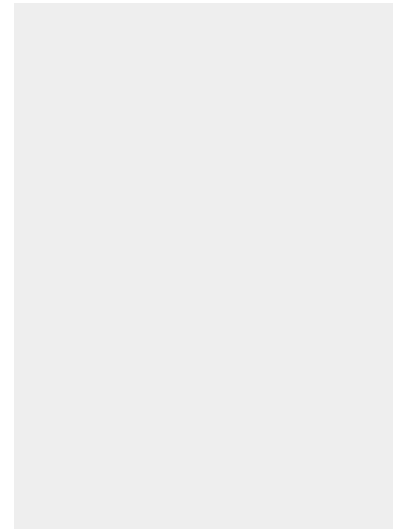



# HVME-006 Protected module

830V 16A

## Inserts



Combination with hinged frame and other modules possible.

## Technical characteristics

Specifications	DIN EN 60 664 DIN EN 61 984		
Approvals			
Inserts		Contacts	
Number of contacts	6	Material	copper alloy
Electrical data acc. to EN 61 984		Surface	hard-silver plated hard-gold plated
-Rated current	16A	Contact resistance	≤ 1mΩ
-Rated voltage	830V	Crimp terminal	
-Rated impulse voltage	8kV	-mm <sup>2</sup>	0.14-4mm <sup>2</sup>
-Pollution degree	3	-AWG	26-12
Rated voltage acc. to UL	600V		
Insulation resistance	≥ 10 <sup>10</sup> Ω		
Material	polycarbonate		
Limiting temperatures	-40°C ...+125°C		
Flammability acc. to UL 94	V0		
Mechanical working life			
- mating cycles	≥ 500		

### Current carrying capacity

The current carrying is limited by maximum temperature of materials for inserts and contacts including terminals

Control and test procedures according to DIN EN 60512-5

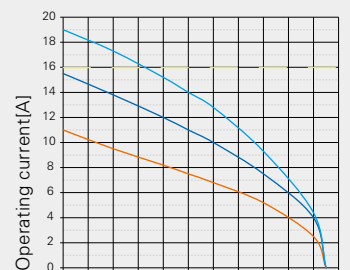

Ambient temperature[°C]

- 24 B hoods/housings with 6 modules, wire gauge: 4.0mm<sup>2</sup>
- 24 B hoods/housings with 6 modules, wire gauge: 2.5mm<sup>2</sup>
- 24 B hoods/housings with 6 modules, wire gauge: 1.5mm<sup>2</sup>

### Crimp terminal

Order crimp contacts separately



Insert	Designation	Order No.
Male	HVME-006-MC	129 006 010 0101
Female	HVME-006-FC	129 006 020 0101

## Crimp contacts

### Crimp contacts 16A

Contact resistance ≤ 1mΩ  
silver plated



gold plated



Male	Order No.	Female	Order No.
CESM-0.37	101 019 110 0301	CESF-0.37	101 019 120 0301
CESM-0.50	101 019 110 0401	CESF-0.50	101 019 120 0401
CESM-0.75	101 019 110 0601	CESF-0.75	101 019 120 0601
CESM-1.0	101 019 110 0801	CESF-1.0	101 019 120 0801
CESM-1.5	101 019 110 0901	CESF-1.5	101 019 120 0901
CESM-2.5	101 019 110 1001	CESF-2.5	101 019 120 1001
CESM-3.0	101 019 110 1101	CESF-3.0	101 019 120 1101
CESM-4.0	101 019 110 1201	CESF-4.0	101 019 120 1201
CEGM-0.37	101 019 210 0301	CEGF-0.37	101 019 220 0301
CEGM-0.50	101 019 210 0401	CEGF-0.50	101 019 220 0401
CEGM-0.75	101 019 210 0601	CEGF-0.75	101 019 220 0601
CEGM-1.0	101 019 210 0801	CEGF-1.0	101 019 220 0801
CEGM-1.5	101 019 210 0901	CEGF-1.5	101 019 220 0901
CEGM-2.5	101 019 210 1001	CEGF-2.5	101 019 220 1001
CEGM-3.0	101 019 210 1101	CEGF-3.0	101 019 220 1101
CEGM-4.0	101 019 210 1201	CEGF-4.0	101 019 220 1201

More crimp contacts 16A see P13-04.

### Tools

#### Crimping tool



#### Contact removal tool



Wire gauge	Designation	Order No.
0.14-4mm <sup>2</sup>	TL02G	198 001 001 0011
Wire gauge: 0.14-0.37mm <sup>2</sup> please select TL02 Crimping tool.		
Application	Designation	Order No.
for crimp contacts 16A	TL01	198 001 000 0002

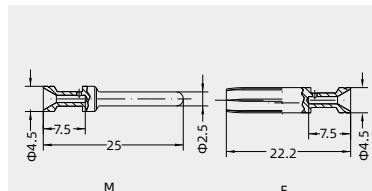
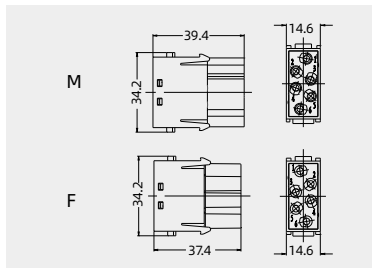

Identification	Wire gauge	Stripping length
no groove	0.14-0.37 mm <sup>2</sup>   AWG 26-22	7.5mm
no groove	0.5 mm <sup>2</sup>   AWG 20	7.5mm
1 groove	0.75 mm <sup>2</sup>   AWG 18	7.5mm
1 groove	1 mm <sup>2</sup>   AWG 18	7.5mm
2 grooves	1.5 mm <sup>2</sup>   AWG 16	7.5mm
3 grooves	2.5 mm <sup>2</sup>   AWG 14	7.5mm
wide groove	3 mm <sup>2</sup>   AWG 12	7.5mm
no groove	4 mm <sup>2</sup>   AWG 12	7.5mm

When the wire gauge is less than 0.75mm<sup>2</sup>, it's better to use the auxiliary pin assembly tool TL15.

# HMEE-008 Crimp module

400V 16A

Inserts



Combination with hinged frame and other modules possible.

## Technical characteristics

Specifications	DIN EN 60 664 DIN EN 61 984		
Approvals			
Inserts	Contacts		
Number of contacts	8	Material	copper alloy
Electrical data acc. to EN 61 984		Surface	hard-silver plated
-Rated current	16A		hard-gold plated
-Rated voltage	400V	Contact resistance	≤ 1mΩ
-Rated impulse voltage	6kV	Crimp terminal	
-Pollution degree	3	-mm <sup>2</sup>	0.14-4mm <sup>2</sup>
Rated voltage acc. to UL	600V	-AWG	26-12
Insulation resistance	≥ 10 <sup>10</sup> Ω		
Material	polycarbonate		
Limiting temperatures	-40°C ...+125°C		
Flammability acc. to UL 94	V0		
Mechanical working life			
- mating cycles	≥ 500		

### Current carrying capacity

The current carrying is limited by maximum temperature of materials for inserts and contacts including terminals

Control and test procedures according to DIN EN 60512-5

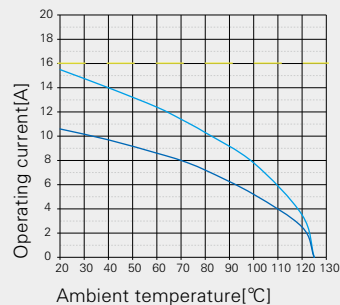

- 24 B hoods/housings with 6 modules, wire gauge: 2.5mm<sup>2</sup>
- 24 B hoods/housings with 6 modules, wire gauge: 1.5mm<sup>2</sup>

### Crimp terminal

Order crimp contacts separately



Insert	Designation	Order No.
Male	HMEE-008-MC	129 008 010 0001
Female	HMEE-008-FC	129 008 020 0001

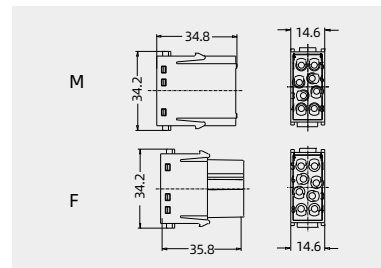

## Crimp contacts

### Crimp contacts 16A

Contact resistance ≤ 1mΩ silver plated



gold plated



Male	Order No.	Female	Order No.
CESM-0.37	101 019 110 0301	CESF-0.37	101 019 120 0301
CESM-0.50	101 019 110 0401	CESF-0.50	101 019 120 0401
CESM-0.75	101 019 110 0601	CESF-0.75	101 019 120 0601
CESM-1.0	101 019 110 0801	CESF-1.0	101 019 120 0801
CESM-1.5	101 019 110 0901	CESF-1.5	101 019 120 0901
CESM-2.5	101 019 110 1001	CESF-2.5	101 019 120 1001
CESM-3.0	101 019 110 1101	CESF-3.0	101 019 120 1101
CESM-4.0	101 019 110 1201	CESF-4.0	101 019 120 1201
CEGM-0.37	101 019 210 0301	CEGF-0.37	101 019 220 0301
CEGM-0.50	101 019 210 0401	CEGF-0.50	101 019 220 0401
CEGM-0.75	101 019 210 0601	CEGF-0.75	101 019 220 0601
CEGM-1.0	101 019 210 0801	CEGF-1.0	101 019 220 0801
CEGM-1.5	101 019 210 0901	CEGF-1.5	101 019 220 0901
CEGM-2.5	101 019 210 1001	CEGF-2.5	101 019 220 1001
CEGM-3.0	101 019 210 1101	CEGF-3.0	101 019 220 1101
CEGM-4.0	101 019 210 1201	CEGF-4.0	101 019 220 1201

More crimp contacts 16A see P13-04.

### Tools

Crimping tool



Contact removal tool



Wire gauge	Designation	Order No.
0.14-4mm <sup>2</sup>	TL02G	198 001 001 0011
Wire gauge: 0.14-0.37mm <sup>2</sup> please select TL02 Crimping tool.		
Application	Designation	Order No.
for crimp contacts 16A	TL01	198 001 000 0002

Identification	Wire gauge	Stripping length
no groove	0.14-0.37 mm <sup>2</sup>   AWG 26-22	7.5mm
no groove	0.5 mm <sup>2</sup>   AWG 20	7.5mm
1 groove	0.75 mm <sup>2</sup>   AWG 18	7.5mm
1 groove	1 mm <sup>2</sup>   AWG 18	7.5mm
2 grooves	1.5 mm <sup>2</sup>   AWG 16	7.5mm
3 grooves	2.5 mm <sup>2</sup>   AWG 14	7.5mm
wide groove	3 mm <sup>2</sup>   AWG 12	7.5mm
no groove	4 mm <sup>2</sup>   AWG 12	7.5mm

When the wire gauge is less than 0.75mm<sup>2</sup>, it's better to use the auxiliary pin assembly tool TL15.

Notes: The tools for crimp terminal may influence the product quality and stability. Please select the tools recognized by our company.

# HMEE-008 Quick-in module

400V 16A

Inserts



Combination with hinged frame and other modules possible.

## Technical characteristics

Specifications	DIN EN 60 664 DIN EN 61 984		
Approvals			
Inserts		Contacts	
No.of contact	8	Terminal	spring terminal(Quick-in)
-Rated current	16A	Material	copper alloy
-Rated voltage	400V	Surface	hard-silver plated
-Rated impulse voltage	6kV	Contact resistance	≤ 3mΩ
-Pollution degree	3	Wire gauge	
Insulation resistance	≥ 10 <sup>10</sup> Ω	-mm <sup>2</sup>	0.5-4.0mm <sup>2</sup>
Material	polycarbonate	-AWG	20-12
Colour	RAL 7032(light grey)	(For wires with crimped ferrule, wire gauge)	
Limiting temperatures	-40°C ...+125°C	-mm <sup>2</sup>	0.14-2.5mm <sup>2</sup>
Flammability acc. to UL 94	V0	-AWG	26-14
Mating cycles	≥ 500	Stripping length	10±0.5mm

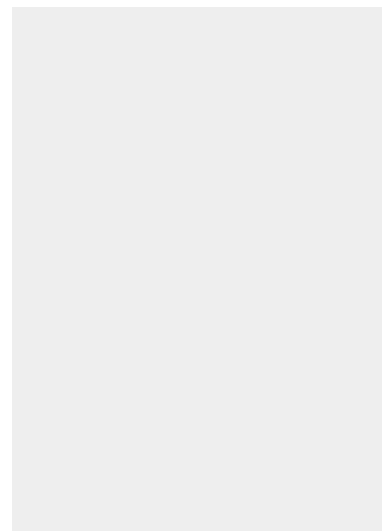

## Spring terminal(Quick-in)



Insert	Designation	Order No.
Male	HMEE-008-MQ	129 008 001 0001
Female	HMEE-008-FQ	129 008 002 0001

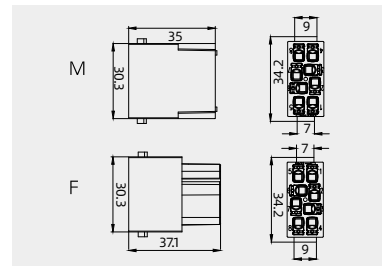

## H2MEE-020 Crimp module

500V 16A

Inserts



Combination with hinged frame and other modules possible.

### Technical characteristics

Specifications	DIN EN 60 664 DIN EN 61 984		
Approvals			
Inserts		Contacts	
Number of contacts	20	Material	copper alloy
Electrical data acc. to EN 61 984		Surface	hard-silver plated
-Rated current	16A		hard-gold plated
-Rated voltage	500V	Contact resistance	≤ 1mΩ
-Rated impulse voltage	6kV	Crimp terminal	
-Pollution degree	3	-mm <sup>2</sup>	0.14-4mm <sup>2</sup>
Rated voltage acc. to UL	600V	-AWG	26-12
Insulation resistance	≥ 10 <sup>10</sup> Ω		
Material	polycarbonate		
Limiting temperatures	-40°C ...+125°C		
Flammability acc. to UL 94	V0		
Mechanical working life			
- mating cycles	≥ 500		

### Current carrying capacity

The current carrying is limited by maximum temperature of materials for inserts and contacts including terminals

Control and test procedures according to DIN EN 60512-5

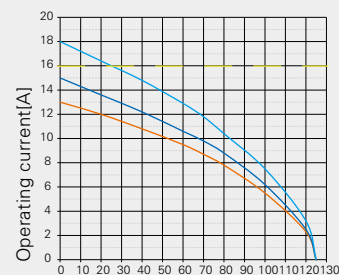

- 24 B hoods/housings with 3 modules, wire gauge: 4.0mm<sup>2</sup>
- 24 B hoods/housings with 3 modules, wire gauge: 2.5mm<sup>2</sup>
- 24 B hoods/housings with 3 modules, wire gauge: 1.5mm<sup>2</sup>

### Crimp terminal

Order crimp contacts separately



Insert	Designation	Order No.
Male	H2MEE-020-MC	129 020 010 0001
Female	H2MEE-020-FC	129 020 020 0001

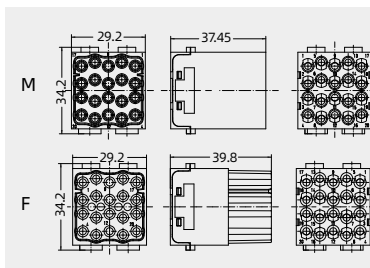

### Crimp contacts

Crimp contacts 16A

Contact resistance ≤ 1mΩ silver plated



gold plated



Male	Order No.	Female	Order No.
CESM-0.37	101 019 110 0301	CESF-0.37	101 019 120 0301
CESM-0.50	101 019 110 0401	CESF-0.50	101 019 120 0401
CESM-0.75	101 019 110 0601	CESF-0.75	101 019 120 0601
CESM-1.0	101 019 110 0801	CESF-1.0	101 019 120 0801
CESM-1.5	101 019 110 0901	CESF-1.5	101 019 120 0901
CESM-2.5	101 019 110 1001	CESF-2.5	101 019 120 1001
CESM-3.0	101 019 110 1101	CESF-3.0	101 019 120 1101
CESM-4.0	101 019 110 1201	CESF-4.0	101 019 120 1201
CEGM-0.37	101 019 210 0301	CEGF-0.37	101 019 220 0301
CEGM-0.50	101 019 210 0401	CEGF-0.50	101 019 220 0401
CEGM-0.75	101 019 210 0601	CEGF-0.75	101 019 220 0601
CEGM-1.0	101 019 210 0801	CEGF-1.0	101 019 220 0801
CEGM-1.5	101 019 210 0901	CEGF-1.5	101 019 220 0901
CEGM-2.5	101 019 210 1001	CEGF-2.5	101 019 220 1001
CEGM-3.0	101 019 210 1101	CEGF-3.0	101 019 220 1101
CEGM-4.0	101 019 210 1201	CEGF-4.0	101 019 220 1201

More crimp contacts 16A see P13-04.

Tools

Crimping tool



Contact removal tool



Wire gauge	Designation	Order No.
0.14-4mm <sup>2</sup>	TL02G	198 001 001 0011
Wire gauge: 0.14-0.37mm <sup>2</sup> please select TL02 Crimping tool.		
Application	Designation	Order No.
for crimp contacts 16A	TL01	198 001 000 0002

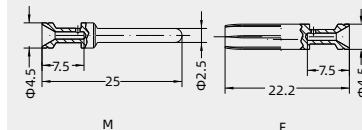

Identification	Wire gauge	Stripping length	
no groove	0.14-0.37 mm <sup>2</sup>	AWG 26-22	7.5mm
no groove	0.5 mm <sup>2</sup>	AWG 20	7.5mm
1 groove	0.75 mm <sup>2</sup>	AWG 18	7.5mm
1 groove	1 mm <sup>2</sup>	AWG 18	7.5mm
2 grooves	1.5 mm <sup>2</sup>	AWG 16	7.5mm
3 grooves	2.5 mm <sup>2</sup>	AWG 14	7.5mm
wide groove	3 mm <sup>2</sup>	AWG 12	7.5mm
no groove	4 mm <sup>2</sup>	AWG 12	7.5mm

When the wire gauge is less than 0.75mm<sup>2</sup>, it's better to use the auxiliary pin assembly tool TL15.

Notes: The tools for crimp terminal may influence the product quality and stability. Please select the tools recognized by our company.

# HMD-012 Crimp module

250V 10A

Inserts



Combination with hinged frame and other modules possible.

## Technical characteristics

Specifications	DIN EN 60 664 DIN EN 61 984		
Approvals			
Inserts		Contacts	
Number of contacts	12	Material	copper alloy
Electrical data acc. to EN 61 984		Surface	hard-silver plated hard-gold plated
-Rated current	10A	Contact resistance	≤ 3mΩ
-Rated voltage	250V	Crimp terminal	
-Rated impulse voltage	4kV	-mm <sup>2</sup>	0.14-2.5mm <sup>2</sup>
-Pollution degree	3	-AWG	26-14
Rated voltage acc. to UL	600V		
Insulation resistance	≥ 10 <sup>10</sup> Ω		
Material	polycarbonate		
Limiting temperatures	-40°C ... +125°C		
Flammability acc. to UL 94	V0		
Mechanical working life			
- mating cycles	≥ 500		

### Current carrying capacity

The current carrying is limited by maximum temperature of materials for inserts and contacts including terminals

Control and test procedures according to DIN EN 60512-5

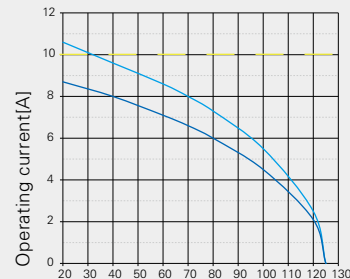

Ambient temperature [°C]

- 24 B hoods/housings with 6 modules, wire gauge: 1.5mm<sup>2</sup>
- 24 B hoods/housings with 6 modules, wire gauge: 1.0mm<sup>2</sup>

### Crimp terminal

Order crimp contacts separately



Insert	Designation	Order No.
Male	HMD-012-MC	129 012 010 0001
Female	HMD-012-FC	129 012 020 0001

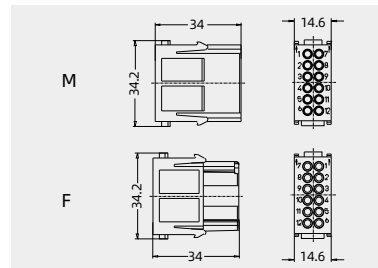

## Crimp contacts

### Crimp contacts 10A

Contact resistance ≤ 3mΩ silver plated



gold plated



Male	Order No.	Female	Order No.
CDSM-0.25	101 017 110 0101	CDSF-0.25	101 017 120 0101
CDSM-0.37	101 017 110 0301	CDSF-0.37	101 017 120 0301
CDSM-0.50	101 017 110 0401	CDSF-0.50	101 017 120 0401
CDSM-0.75	101 017 110 0601	CDSF-0.75	101 017 120 0601
CDSM-1.0	101 017 110 0801	CDSF-1.0	101 017 120 0801
CDSM-1.5	101 017 110 0901	CDSF-1.5	101 017 120 0901
CDSM-2.5	101 017 110 1001	CDSF-2.5	101 017 120 1001
CDGM-0.25	101 017 210 0101	CDGF-0.25	101 017 220 0101
CDGM-0.37	101 017 210 0301	CDGF-0.37	101 017 220 0301
CDGM-0.50	101 017 210 0401	CDGF-0.50	101 017 220 0401
CDGM-0.75	101 017 210 0601	CDGF-0.75	101 017 220 0601
CDGM-1.0	101 017 210 0801	CDGF-1.0	101 017 220 0801
CDGM-1.5	101 017 210 0901	CDGF-1.5	101 017 220 0901
CDGM-2.5	101 017 210 1001	CDGF-2.5	101 017 220 1001

More crimp contacts 10A see P13-02,P13-02.

### Tools

Crimping tool



Contact removal tool



Wire gauge	Designation	Order No.
0.14-4mm <sup>2</sup>	TL02G	198 001 001 0011
For the crimping contacts and removing contacts instructions, please find the page 06-23-06-24.		
Application	Designation	Order No.
for crimp contacts 10A	TL00	198 001 000 0001

More tools detail please find the page 32-03-32-06.

Wire gauge	AWG	Φ	Stripping length
0.09-0.25 mm <sup>2</sup>	AWG 28-24	0.65	5 mm
0.14-0.37 mm <sup>2</sup>	AWG 26-22	0.9	8 mm
0.5 mm <sup>2</sup>	AWG 20	1.1	8 mm
0.75 mm <sup>2</sup>	AWG 18	1.3	8 mm
1 mm <sup>2</sup>	AWG 18	1.45	8 mm
1.5 mm <sup>2</sup>	AWG 16	1.75	8 mm
2.5 mm <sup>2</sup>	AWG 14	2.25	6 mm

When the wire gauge is less than 0.75mm<sup>2</sup>, it's better to use the auxiliary pin assembly tool TL15.

Notes: The tools for crimp terminal may influence the product quality and stability. Please select the tools recognized by our company.

# HMD-012 Quick-in module

250V 10A

Inserts



Combination with hinged frame and other modules possible.

## Technical characteristics

Specifications	DIN EN 60 664 DIN EN 61 984		
Approvals			
Inserts	Contacts		
No. of contact	12	Terminal	Spring terminal(Quick-in)
Electrical data acc. to EN 61 984		Material	copper alloy
-Rated current	10A	Surface	hard-silver plated
-Rated voltage	250V	Contact resistance	≤ 3mΩ
-Rated impulse voltage	4kV	Wire gauge	
-Pollution degree	3	-mm <sup>2</sup>	0.5-2.5mm <sup>2</sup>
Rated voltage acc. to UL	250V	-AWG	20-14
Insulation resistance	≥ 10 <sup>10</sup> Ω	(For wires with crimped ferrule, wire gauge)	
Material	polycarbonate	-mm <sup>2</sup>	0.14-1.5mm <sup>2</sup>
Colour	RAL 7032(light grey)	-AWG	26-16
Limiting temperatures	-40°C ...+125°C	Stripping length	10±0.5mm
Flammability acc. to UL 94	V0		
Mating cycles	≥ 500		

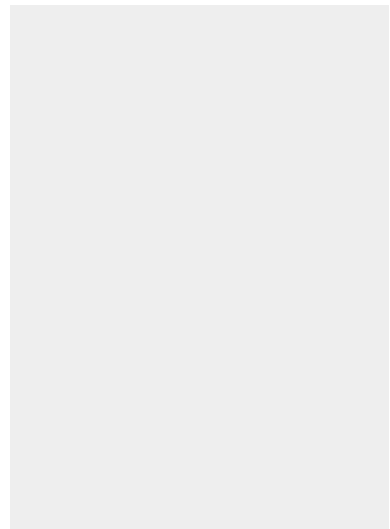

## Spring terminal(Quick-in)



Insert	Designation	Order No.
Male	HMD-012-MQ	129 012 001 0001
Female	HMD-012-FQ	129 012 002 0001

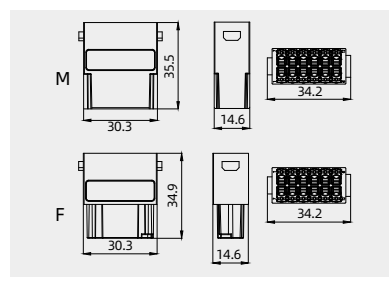

# HMDD-017 Crimp module

160V 10A

Inserts



Combination with hinged frame and other modules possible.

## Technical characteristics

Specifications	DIN EN 60 664 DIN EN 61 984		
Approvals			
Inserts		Contacts	
Number of contacts	17	Material	copper alloy
Electrical data acc. to EN 61 984		Surface	hard-silver plated
-Rated current	10A		hard-gold plated
-Rated voltage	160V	Contact resistance	≤ 3mΩ
-Rated impulse voltage	2.5kV	Crimp terminal	
-Pollution degree	3	-mm <sup>2</sup>	0.14-2.5mm <sup>2</sup>
Rated voltage acc. to UL	250V	-AWG	26-14
Insulation resistance	≥ 10 <sup>10</sup> Ω		
Material	polycarbonate		
Limiting temperatures	-40°C ...+125°C		
Flammability acc. to UL 94	V0		
Mechanical working life			
- mating cycle	≥ 500		

### Current carrying capacity

The current carrying is limited by maximum temperature of materials for inserts and contacts including terminals

Control and test procedures according to DIN EN 60512-5

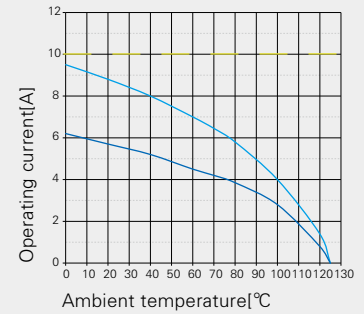

- 24 B hoods/housings with 6 modules, wire gauge: 1.5mm<sup>2</sup>
- 24 B hoods/housings with 6 modules, wire gauge: 1.0mm<sup>2</sup>

### Crimp terminal

Order crimp contacts separately



Insert	Designation	Order No.
Male	HMDD-017-MC	129 017 010 0001
Female	HMDD-017-FC	129 017 020 0001

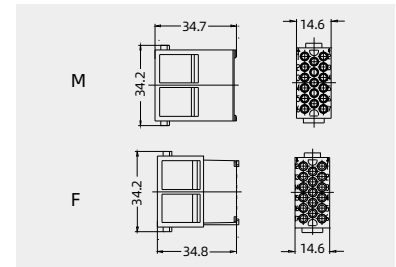

## Crimp contacts

### Crimp contacts 10A

Contact resistance ≤ 3mΩ  
silver plated



gold plated



More crimp contacts 10A  
see P13-02, P13-02.

Male	Order No.	Female	Order No.
CDSM-0.25	101 017 110 0101	CDSF-0.25	101 017 120 0101
CDSM-0.37	101 017 110 0301	CDSF-0.37	101 017 120 0301
CDSM-0.50	101 017 110 0401	CDSF-0.50	101 017 120 0401
CDSM-0.75	101 017 110 0601	CDSF-0.75	101 017 120 0601
CDSM-1.0	101 017 110 0801	CDSF-1.0	101 017 120 0801
CDSM-1.5	101 017 110 0901	CDSF-1.5	101 017 120 0901
CDSM-2.5	101 017 110 1001	CDSF-2.5	101 017 120 1001
CDGM-0.25	101 017 210 0101	CDGF-0.25	101 017 220 0101
CDGM-0.37	101 017 210 0301	CDGF-0.37	101 017 220 0301
CDGM-0.50	101 017 210 0401	CDGF-0.50	101 017 220 0401
CDGM-0.75	101 017 210 0601	CDGF-0.75	101 017 220 0601
CDGM-1.0	101 017 210 0801	CDGF-1.0	101 017 220 0801
CDGM-1.5	101 017 210 0901	CDGF-1.5	101 017 220 0901
CDGM-2.5	101 017 210 1001	CDGF-2.5	101 017 220 1001

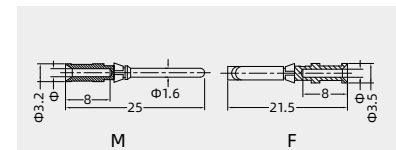

Wire gauge	Φ	Stripping length
0.09-0.25 mm <sup>2</sup>	AWG 28-24	0.65 5 mm
0.14-0.37 mm <sup>2</sup>	AWG 26-22	0.9 8 mm
0.5 mm <sup>2</sup>	AWG 20	1.1 8 mm
0.75 mm <sup>2</sup>	AWG 18	1.3 8 mm
1 mm <sup>2</sup>	AWG 18	1.45 8 mm
1.5 mm <sup>2</sup>	AWG 16	1.75 8 mm
2.5 mm <sup>2</sup>	AWG 14	2.25 6 mm

When the wire gauge is less than 0.75mm<sup>2</sup>, it's better to use the auxiliary pin assembly tool TL15.

### Tools

Crimping tool



Contact removal tool



Wire gauge	Designation	Order No.
0.14-4mm <sup>2</sup>	TL02G	198 001 001 0011
For the crimping contacts and removing contacts instructions, please find the page 06-23-06-24.		
Application	Designation	Order No.
for crimp contacts 10A	TL00	198 001 000 0001
More tools detail please find the page 32-03-32-06.		

Notes: The tools for crimp terminal may influence the product quality and stability. Please select the tools recognized by our company.

## H2MDD-042 Crimp module

150V 10A

Inserts



Combination with hinged frame and other modules possible.

### Technical characteristics

Specifications	DIN EN 60 664 DIN EN 61 984		
Approvals			
Inserts		Contacts	
Number of contacts	42	Material	copper alloy
Electrical data acc. to EN 61 984		Surface	hard-silver plated
-Rated current	10A		hard-gold plated
-Rated voltage	150V	Contact resistance	≤ 3mΩ
-Rated impulse voltage	2.5kV	Crimp terminal	
-Pollution degree	3	-mm <sup>2</sup>	0.14-2.5mm <sup>2</sup>
Rated voltage acc. to UL	250V	-AWG	26-14
Insulation resistance	≥ 10 <sup>10</sup> Ω		
Material	polycarbonate		
Limiting temperatures	-40°C ...+125°C		
Flammability acc. to UL 94	V0		
Mechanical working life			
- mating cycles	≥ 500		

### Crimp terminal

Order crimp contacts separately



Insert	Designation	Order No.
Male	H2MDD-042-MC	129 042 010 0001
Female	H2MDD-042-FC	129 042 020 0001

### Crimp contacts

#### Crimp contacts 10A

Contact resistance ≤ 3mΩ  
silver plated



Male	Order No.	Female	Order No.
CDSM-0.25	101 017 110 0101	CDSF-0.25	101 017 120 0101
CDSM-0.37	101 017 110 0301	CDSF-0.37	101 017 120 0301
CDSM-0.50	101 017 110 0401	CDSF-0.50	101 017 120 0401
CDSM-0.75	101 017 110 0601	CDSF-0.75	101 017 120 0601
CDSM-1.0	101 017 110 0801	CDSF-1.0	101 017 120 0801
CDSM-1.5	101 017 110 0901	CDSF-1.5	101 017 120 0901
CDSM-2.5	101 017 110 1001	CDSF-2.5	101 017 120 1001

gold plated



Male	Order No.	Female	Order No.
CDGM-0.25	101 017 210 0101	CDGF-0.25	101 017 220 0101
CDGM-0.37	101 017 210 0301	CDGF-0.37	101 017 220 0301
CDGM-0.50	101 017 210 0401	CDGF-0.50	101 017 220 0401
CDGM-0.75	101 017 210 0601	CDGF-0.75	101 017 220 0601
CDGM-1.0	101 017 210 0801	CDGF-1.0	101 017 220 0801
CDGM-1.5	101 017 210 0901	CDGF-1.5	101 017 220 0901
CDGM-2.5	101 017 210 1001	CDGF-2.5	101 017 220 1001

More crimp contacts 10A  
see P13-02,P13-02.

### Tools

Crimping tool



Contact removal tool



Wire gauge	Designation	Order No.
0.14-4mm <sup>2</sup>	TL02G	198 001 001 0011

For the crimping contacts and removing contacts instructions, please find the page 06-23-06-24.

Application	Designation	Order No.
for crimp contacts 10A	TL00	198 001 000 0001

More tools detail please find the page 32-03~32-06.

Notes: The tools for crimp terminal may influence the product quality and stability. Please select the tools recognized by our company.

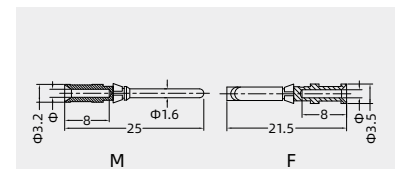
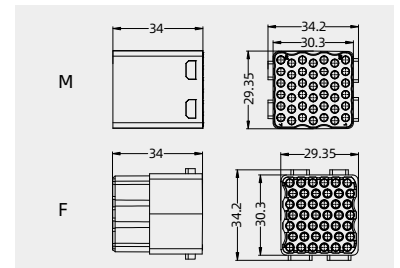
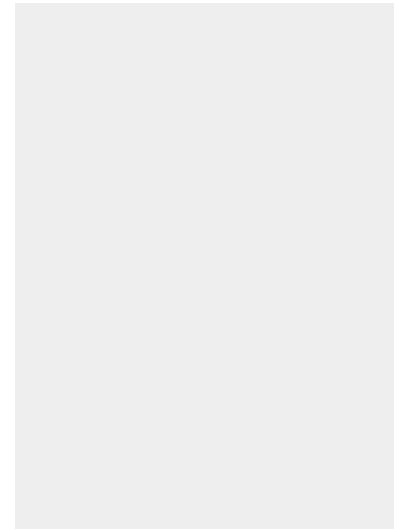

Wire gauge	φ	Stripping length
0.09-0.25 mm <sup>2</sup> AWG 28-24	0.65	5 mm
0.14-0.37 mm <sup>2</sup> AWG 26-22	0.9	8 mm
0.5 mm <sup>2</sup> AWG 20	1.1	8 mm
0.75 mm <sup>2</sup> AWG 18	1.3	8 mm
1 mm <sup>2</sup> AWG 18	1.45	8 mm
1.5 mm <sup>2</sup> AWG 16	1.75	8 mm
2.5 mm <sup>2</sup> AWG 14	2.25	6 mm

When the wire gauge is less than 0.75mm<sup>2</sup>, it's better to use the auxiliary pin assembly tool TL15.



# HMMB-008 MegaBit module

## - Two outlet hole

50V 10A

Inserts



Only suitable for high constructure top entry hood/BK.  
Combination with hinged frame and other modules possible.

### Technical characteristics

Specifications	DIN EN 60 664 DIN EN 61 984		
Approvals	<b>UL 94 V0</b>		
Adapter module		MegaBit Insert	
Number of contacts	1	Contacts	2x4+shielding
Insulation resistance	$\geq 10^{10}\Omega$	Electrical dataacc. to EN 61 984	
Material	polycarbonate	-Rated current	10A
Limiting temperatures	-40°C ...+125°C	-Rated voltage	50V
Flammability acc. to UL 94	V0	-Rated impulse voltage	0.8kV
Mechanical working life		-Pollution degree	3
- mating cycle	$\geq 500$	Material	
Contacts		-insert	polycarbonate
Crimp terminal	hard-gold plated	-outer conductor	zinc alloy
-mm2	0.14-2.5 mm <sup>2</sup>	Insulation resistance	$\leq 4m\Omega$
-AWG	26-14	Limiting temperatures	-40°C ...+85°C
		Flammability acc. to UL 94	V0
		Surface	passivated
		Clamping range	5-12 mm

MegaBit Insert, Crimp terminal  
Order the adapter module separately.  
Order crimp contacts separately.



Insert	Designation	Order No.
Male	HMMB-008-MC	129 008 010 0503
Female	HMMB-008-FC	129 008 020 0503

Adapter module



Insert	Designation	Order No.
Male	HMB.C-M	129 000 001 0001
Female	HMB.C-F	129 000 002 0001

### Crimp contacts

Crimp contacts 10A

Contact resistance  $\leq 3m\Omega$   
silver plated



More crimp contacts 10A  
see P13-02,P13-02.

Tools

Crimping tool



Contact removal tool



Male	Order No.	Female	Order No.
CDGM-0.25	101 017 210 0101	CDGF-0.25	101 017 220 0101
CDGM-0.37	101 017 210 0301	CDGF-0.37	101 017 220 0301
CDGM-0.50	101 017 210 0401	CDGF-0.50	101 017 220 0401
CDGM-0.75	101 017 210 0601	CDGF-0.75	101 017 220 0601
CDGM-1.0	101 017 210 0801	CDGF-1.0	101 017 220 0801
CDGM-1.5	101 017 210 0901	CDGF-1.5	101 017 220 0901
CDGM-2.5	101 017 210 1001	CDGF-2.5	101 017 220 1001

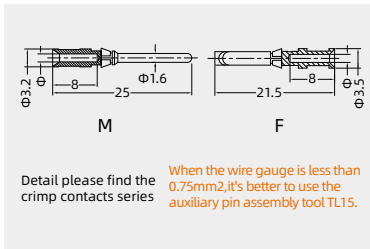
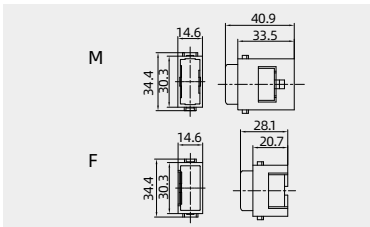
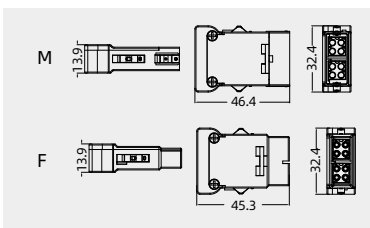
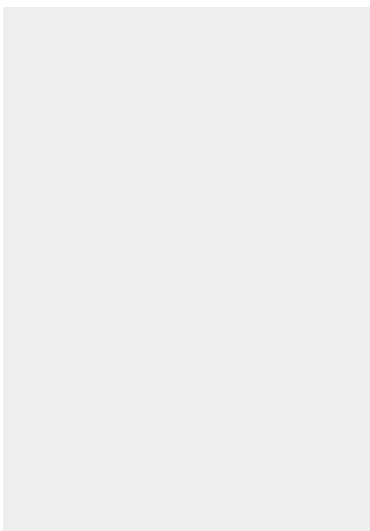

Detail please find the crimp contacts series  
When the wire gauge is less than 0.75mm<sup>2</sup>, it's better to use the auxiliary pin assembly tool TL15.

Notes: The tools for crimp terminal may influence the product quality and stability. Please select the tools recognized by our company.

# HM/MB/1-008 MegaBit module - One outlet hole

50V 10A

Inserts



Only suitable for high constructure top entry hood/BK.  
Combination with hinged frame and other modules possible.

## Technical characteristics

Specifications	DIN EN 60 664 DIN EN 61 984
<b>Approvals</b>	
Adapter module	MegaBit Insert
Number of contacts	1
Insulation resistance	$\geq 10^{10}\Omega$
Material	polycarbonate
Limiting temperatures	-40°C ...+125°C
Flammability acc. to UL 94	V0
Mechanical working life	
- mating cycle	$\geq 500$
Contacts	
Material	copper alloy
Crimp terminal	hard-silver plated
	hard-gold plated
-mm <sup>2</sup>	0.14-2.5 mm <sup>2</sup>
-AWG	26-14
Contact resistance	$\leq 3m\Omega$

Contacts	2x4
Electrical dataacc. to EN 61 984	
-Rated current	10A
-Rated voltage	50V
-Rated impulse voltage	0.8kV
-Pollution degree	3
Material	
-insert	polycarbonate
-outer conductor	Zinc alloy passivation
Insulation resistance	$\leq 4m\Omega$
Limiting temperatures	-40°C ...+85°C
Flammability acc. to UL 94	V0
Surface	passivated
Clamping range	5-12 mm

### MegaBit Insert, Crimp terminal

Order the adapter module separately.

Order crimp contacts separately.



Insert	Designation	Order No.
Male	HM/MB/1-008-MC	129 008 010 0511
Female	HM/MB/1-008-FC	129 008 020 0511

### Adapter module



Insert	Designation	Order No.
Male	HMB.C-M	129 000 001 0001
Female	HMB.C-F	129 000 002 0001

## Crimp contacts

### Crimp contacts 10A

Contact resistance  $\leq 3m\Omega$   
silver plated



More crimp contacts 10A  
see P13-02,P13-02.

### Tools

#### Crimping tool



#### Contact removal tool



Male	Order No.	Female	Order No.
CDGM-0.25	101 017 210 0101	CDGF-0.25	101 017 220 0101
CDGM-0.37	101 017 210 0301	CDGF-0.37	101 017 220 0301
CDGM-0.50	101 017 210 0401	CDGF-0.50	101 017 220 0401
CDGM-0.75	101 017 210 0601	CDGF-0.75	101 017 220 0601
CDGM-1.0	101 017 210 0801	CDGF-1.0	101 017 220 0801
CDGM-1.5	101 017 210 0901	CDGF-1.5	101 017 220 0901
CDGM-2.5	101 017 210 1001	CDGF-2.5	101 017 220 1001

Wire gauge	Designation	Order No.
0.14-4mm <sup>2</sup>	TL02G	198 001 001 0011

Application	Designation	Order No.
for crimp contacts 10A	TL00	198 001 000 0001

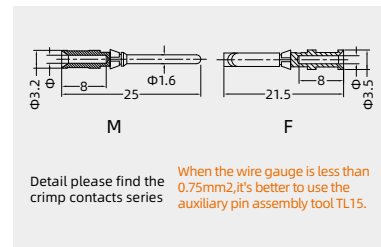
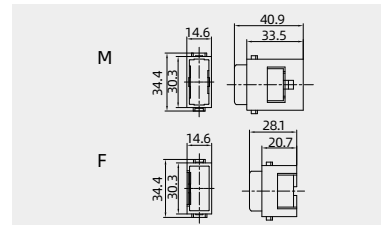
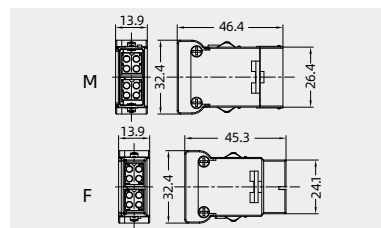
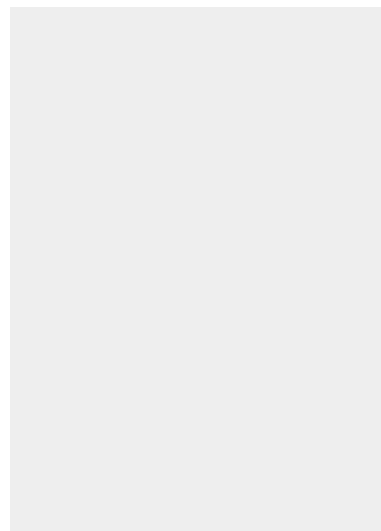

Notes: The tools for crimp terminal may influence the product quality and stability. Please select the tools recognized by our company.

# HMGB-008 GigaBit module

50V 5A

## Inserts



Only suitable for high construction top entry hood/BK.  
Combination with hinged frame and other modules possible.

## Technical characteristics

Specifications	DIN EN 60 664 DIN EN 61 984		
Approvals			
Adapter module		GigaBit module	
Number of contacts	1	Contacts	8+shielding
Insulation resistance	$\geq 10^{10}\Omega$	Electrical dataacc. to EN 61 984	
Material	polycarbonate	-Rated current	5A
Limiting temperatures	-40°C ...+125°C	-Rated voltage	50V
Flammability acc. to UL 94	V0	-Rated impulse voltage	0.8kV
Mechanical working life		-Pollution degree	3
- mating cycle	$\geq 500$	Material	
D-Sub Contacts		-insert	polycarbonate
Crimp terminal	hard-gold plated	-outer conductor	zinc alloy
-mm <sup>2</sup>	0.09-0.52 mm <sup>2</sup>	Insulation resistance	$\leq 4m\Omega$
-AWG	28-20	Limiting temperatures	-40°C ...+85°C
		Flammability acc. to UL 94	V0
		Surface	passivated
		Clamping range	5-12 mm

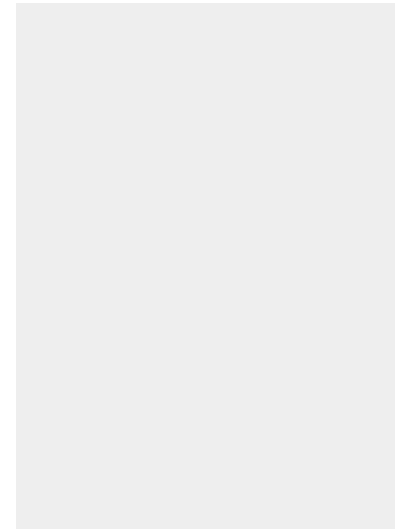

MegaBit Insert, Crimp terminal  
Order the adapter module separately.  
Order crimp contacts separately



Insert	Designation	Order No.
Male	HMGB-008-MC	129 008 010 0002
Female	HMGB-008-FC	129 008 020 0002

Order cable clamp separately.

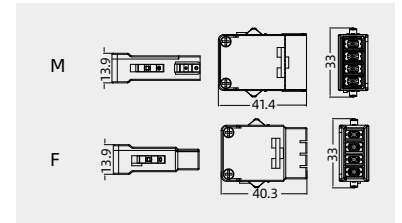

## Adapter module



Insert	Designation	Order No.
Male	HMB.C-M	129 000 001 0001
Female	HMB.C-F	129 000 002 0001

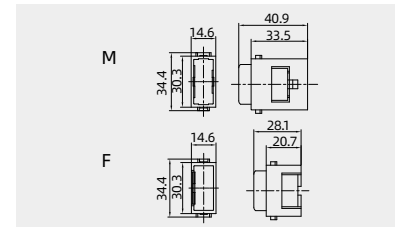

## Crimp contacts

### Crimp contacts 5A

Contact resistance  $\leq 3m\Omega$   
gold plated



Male	Order No.	Female	Order No.
CSGM-0.25	101 014 210 0101	CSGF-0.25	101 014 220 0101
CSGM-0.33	101 014 210 0201	CSGF-0.33	101 014 220 0201
CSGM-0.52	101 014 210 0501	CSGF-0.52	101 014 220 0501

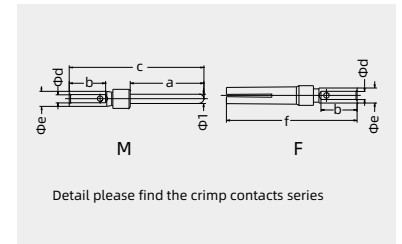

# HMGB-008 GigaBit module

## Stamped contacts 5A

Contact resistance  $\leq 10m\Omega$

silver plated



gold plated



coil stock



Note: 10kpcs/volume

### Tools

Crimping tool



Male	Order No.	Female	Order No.
CSSM-0.82P	101 014 110 0750	CSSF-0.82P	101 014 120 0750
CSGM-0.82P	101 014 210 0750	CSGF-0.82P	101 014 220 0750

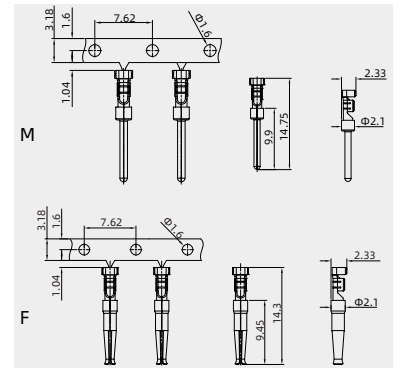

Wire gauge	Designation	Order No.
0.09-0.82mm <sup>2</sup>	TL03	198 001 001 0002

Notes: The tools for crimp terminal may influence the product quality and stability. Please select the tools recognized by our company.

# HMMB-008 MegaBit module

## - Two outlet hole

50V 10A

Inserts



Only suitable for high constructure top entry hood/BK.  
Combination with hinged frame and other modules possible.

### Technical characteristics

Specifications	DIN EN 60 664 DIN EN 61 984		
Approvals			
Adapter module		MegaBit Insert	
Number of contacts	1	Contacts	2x4+shielding
Insulation resistance	$\geq 10^{10}\Omega$	Electrical dataacc. to EN 61 984	
Material	polycarbonate	-Rated current	10A
Limiting temperatures	-40°C ...+125°C	-Rated voltage	50V
Flammability acc. to UL 94	V0	-Rated impulse voltage	0.8kV
Mechanical working life		-Pollution degree	3
- mating cycle	$\geq 500$	Material	
Contacts		-insert	polycarbonate
Crimp terminal	hard-gold plated	-outer conductor	zinc alloy
-mm <sup>2</sup>	0.14-2.5 mm <sup>2</sup>	Insulation resistance	$\leq 4m\Omega$
-AWG	26-14	Limiting temperatures	-40°C ...+85°C
		Flammability acc. to UL 94	V0
		Surface	passivated
		Clamping range	5-12 mm

MegaBit Insert, Crimp terminal  
Order the adapter module separately.  
Order crimp contacts separately



Insert	Designation	Order No.
Male	HMMB-008-MC 3SP	129 008 010 0508
Female	HMMB-008-FC 3SP	129 008 020 0508

Not allow to connect with the frame shield  
Order cable clamp separately.

Adapter module



Insert	Designation	Order No.
Male	HMB.C-M	129 000 001 0001
Female	HMB.C-F	129 000 002 0001

### Crimp contacts

Crimp contacts 10A

Contact resistance  $\leq 3m\Omega$   
silver plated



More crimp contacts 10A  
see P13-02,P13-02.

Tools

Crimping tool



Contact removal tool



Male	Order No.	Female	Order No.
CDGM-0.25	101 017 210 0101	CDGF-0.25	101 017 220 0101
CDGM-0.37	101 017 210 0301	CDGF-0.37	101 017 220 0301
CDGM-0.50	101 017 210 0401	CDGF-0.50	101 017 220 0401
CDGM-0.75	101 017 210 0601	CDGF-0.75	101 017 220 0601
CDGM-1.0	101 017 210 0801	CDGF-1.0	101 017 220 0801
CDGM-1.5	101 017 210 0901	CDGF-1.5	101 017 220 0901
CDGM-2.5	101 017 210 1001	CDGF-2.5	101 017 220 1001

Wire gauge	Designation	Order No.
0.14-4mm <sup>2</sup>	TL02G	198 001 001 0011

Application	Designation	Order No.
for crimp contacts 10A	TL00	198 001 000 0001

Notes: The tools for crimp terminal may influence the product quality and stability. Please select the tools recognized by our company.

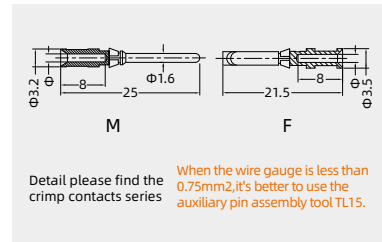
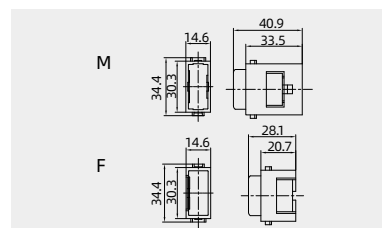
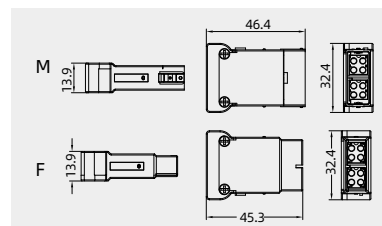
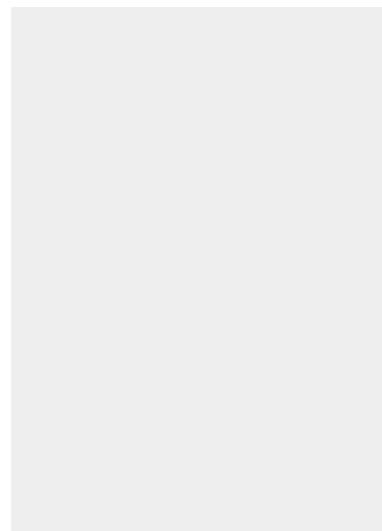

Detail please find the crimp contacts series  
When the wire gauge is less than 0.75mm<sup>2</sup>, it's better to use the auxiliary pin assembly tool TL15.

# HMMB/1-008 MegaBit module

- One outlet hole

50V 10A

## Inserts



Only suitable for high constructure top entry hood/BK. Combination with hinged frame and other modules possible.

## Technical characteristics

Specifications	DIN EN 60 664 DIN EN 61 984
<b>Approvals</b>	
Adapter module	MegaBit Insert
Number of contacts	1
Insulation resistance	$\geq 10^{10}\Omega$
Material	polycarbonate
Limiting temperatures	-40°C ...+125°C
Flammability acc. to UL 94	V0
Mechanical working life	
- mating cycle	$\geq 500$
<b>Contacts</b>	
Material	copper alloy
Crimp terminal	hard-silver plated
	hard-gold plated
-mm <sup>2</sup>	0.14-2.5 mm <sup>2</sup>
-AWG	26-14
Contact resistance	$\leq 3m\Omega$

Contacts	2x4
Electrical dataacc. to EN 61 984	
-Rated current	10A
-Rated voltage	50V
-Rated impulse voltage	0.8kV
-Pollution degree	3
<b>Material</b>	
-insert	polycarbonate
-outer conductor	Zinc alloy passivation
Insulation resistance	$\leq 4m\Omega$
Limiting temperatures	-40°C ...+85°C
Flammability acc. to UL 94	V0
Surface	passivation
Clamping range	5-12 mm

### MegaBit Insert, Crimp terminal

Order the adapter module separately.  
Order crimp contacts separately



Insert	Designation	Order No.
Male	HMMB/1-008-MC 3SP	129 008 010 0510
Female	HMMB/1-008-FC 3SP	129 008 020 0510

**Not allow to connect with the frame shield**  
Order cable clamp separately.

### Adapter module



Insert	Designation	Order No.
Male	HMB.C-M	129 000 001 0001
Female	HMB.C-F	129 000 002 0001

## Crimp contacts

### Crimp contacts 10A

Contact resistance  $\leq 3m\Omega$   
silver plated



More crimp contacts 10A  
see P13-02,P13-02.

### Tools

#### Crimping tool



#### Contact removal tool



Male	Order No.	Female	Order No.
CDGM-0.25	101 017 210 0101	CDGF-0.25	101 017 220 0101
CDGM-0.37	101 017 210 0301	CDGF-0.37	101 017 220 0301
CDGM-0.50	101 017 210 0401	CDGF-0.50	101 017 220 0401
CDGM-0.75	101 017 210 0601	CDGF-0.75	101 017 220 0601
CDGM-1.0	101 017 210 0801	CDGF-1.0	101 017 220 0801
CDGM-1.5	101 017 210 0901	CDGF-1.5	101 017 220 0901
CDGM-2.5	101 017 210 1001	CDGF-2.5	101 017 220 1001

Wire gauge	Designation	Order No.
0.14-4mm <sup>2</sup>	TL02G	198 001 001 0011

Application	Designation	Order No.
for crimp contacts 10A	TL00	198 001 000 0001

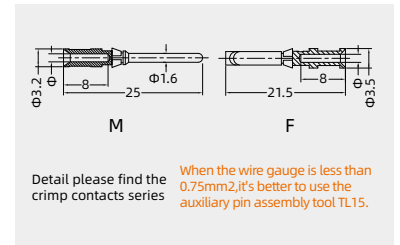
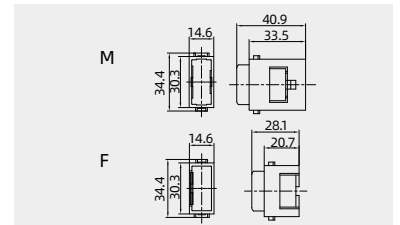
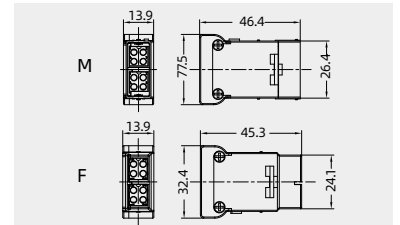
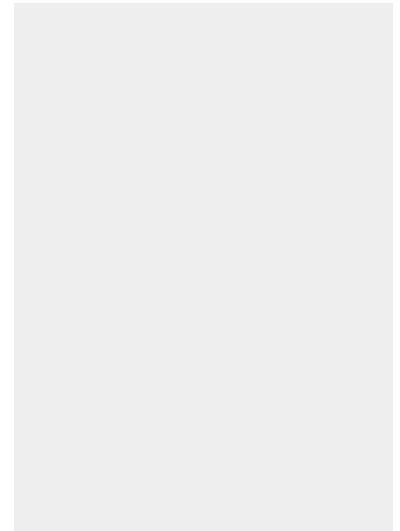

Notes: The tools for crimp terminal may influence the product quality and stability. Please select the tools recognized by our company.

# HMGB-008 GigaBit module

50V 5A

## Inserts



Only suitable for high constructure top entry hood/BK.  
Combination with hinged frame and other modules possible.

## Technical characteristics

Specifications	DIN EN 60 664 DIN EN 61 984	
Approvals		
Adapter module	GigaBit module	
Number of contacts	1	Contacts 8+shielding
Insulation resistance	$\geq 10^{10}\Omega$	Electrical dataacc. to EN 61 984
Material	polycarbonate	-Rated current 5A
Limiting temperatures	-40°C ...+125°C	-Rated voltage 50V
Flammability acc. to UL 94	V0	-Rated impulse voltage 0.8kV
Mechanical working life		-Pollution degree 3
- mating cycle	$\geq 500$	Material
D-Sub Contacts		-insert polycarbonate
Crimp terminal	hard-gold plated	-outer conductor zinc alloy
-mm <sup>2</sup>	0.09-0.52 mm <sup>2</sup>	Insulation resistance $\leq 4m\Omega$
-AWG	28-20	Limiting temperatures -40°C ...+85°C
		Flammability acc. to UL 94 V0
		Surface passivated
		Clamping range 5-12 mm

MegaBit Insert, Crimp terminal  
Order the adapter module separately.  
Order crimp contacts separately



Insert	Designation	Order No.
Male	HMGB-008-MC 3SP	129 008 010 0004
Female	HMGB-008-FC 3SP	129 008 020 0004

Not allow to connect with the frame shield  
Order cable clamp separately.

## Adapter module



Insert	Designation	Order No.
Male	HMB.C-M	129 000 001 0001
Female	HMB.C-F	129 000 002 0001

## Crimp contacts

### Crimp contacts 5A

Contact resistance  $\leq 3m\Omega$   
gold plated



Male	Order No.	Female	Order No.
CSGM-0.25	101 014 210 0101	CSGF-0.25	101 014 220 0101
CSGM-0.33	101 014 210 0201	CSGF-0.33	101 014 220 0201
CSGM-0.52	101 014 210 0501	CSGF-0.52	101 014 220 0501

## Tools

### Crimping tool



Wire gauge	Designation	Order No.
0.09-0.82mm <sup>2</sup>	TL03	198 001 001 0002

Notes: The tools for crimp terminal may influence the product quality and stability. Please select the tools recognized by our company.

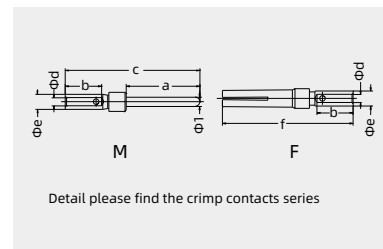
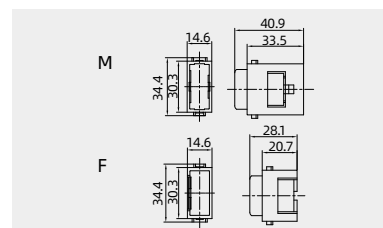
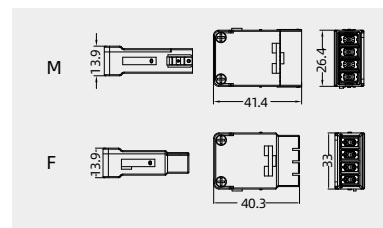
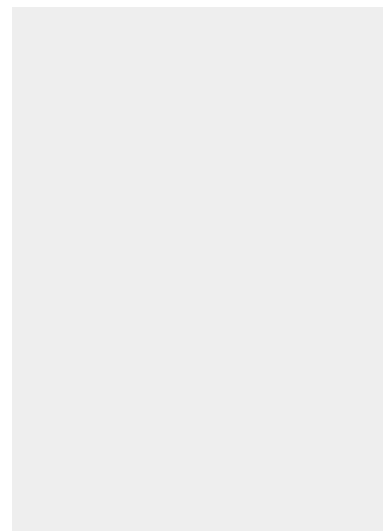

## HMGB-008 GigaBit module

## Stamped contacts 5A

Contact resistance  $\leq 10\text{m}\Omega$ 

silver plated



gold plated



coil stock



Note: 10kpcs/volume

## Tools

Crimping tool



Male	Order No.	Female	Order No.
CSSM-0.82P	101 014 110 0750	CSSF-0.82P	101 014 120 0750
CSGM-0.82P	101 014 210 0750	CSGF-0.82P	101 014 220 0750

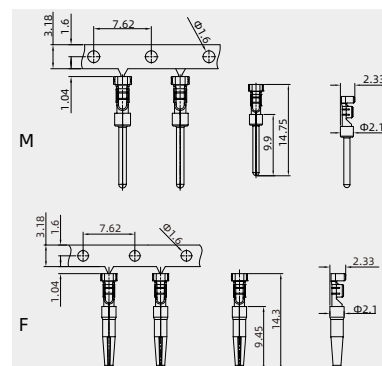

Notes: The tools for crimp terminal may influence the product quality and stability. Please select the tools recognized by our company.



# HMSB-024 Shielding Module

32V 4A

## Inserts



Only suitable for high construction top entry hood/BK.  
Combination with hinged frame and other modules possible.

## Technical characteristics

Specifications	DIN EN 60 664 DIN EN 61 984		
Approvals		HMSB-024 module	
Adapter module		Contacts	24+shielding
Number of contacts	1	Electrical data acc. to EN 61 984	
Insulation resistance	$\geq 10^{10}\Omega$	-Rated current	4A
Material	polycarbonate	-Rated voltage	32V
Limiting temperatures	-40°C ... +125°C	-Rated impulse voltage	0.8kV
Flammability acc. to UL 94	V0	-Pollution degree	3
Mechanical working life		Material	
- mating cycle	$\geq 500$	-insert	polycarbonate
Contacts		-outer conductor	zinc alloy
Crimp terminal	hard-gold plated	Insulation resistance	$\leq 4m\Omega$
-mm <sup>2</sup>	0.09-0.52 mm <sup>2</sup>	Limiting temperatures	-40°C ... +85°C
-AWG	28-20	Flammability acc. to UL 94	V0
		Surface	passivated
		Clamping range	5-12 mm

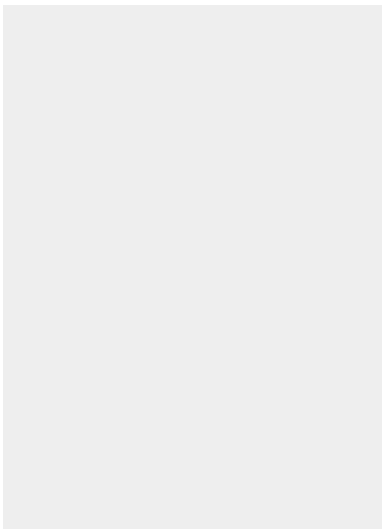

MegaBit Insert, Crimp terminal  
Order the adapter module separately.  
Order crimp contacts separately



Insert	Designation	Order No.
Male	HMSB-024-MC	129 024 010 0001
Female	HMSB-024-FC	129 024 020 0001

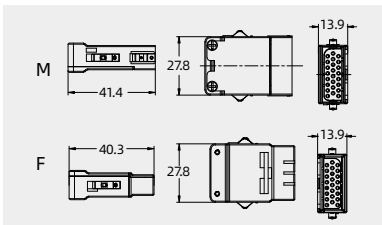

Adapter module



Insert	Designation	Order No.
Male	HMSB.C-M	129 000 011 1001
Female	HMSB.C-F	129 000 021 1001

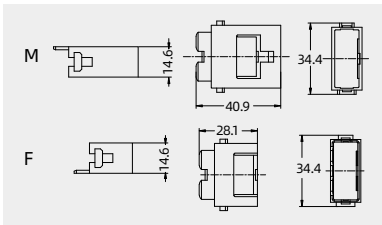

## Crimp contacts

Crimp contacts 5A

Contact resistance  $\leq 3m\Omega$   
gold plated



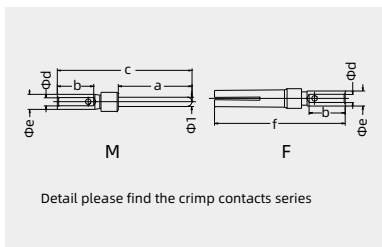

Male	Order No.	Female	Order No.
CSGM-0.25	101 014 210 0101	CSGF-0.25	101 014 220 0101
CSGM-0.33	101 014 210 0201	CSGF-0.33	101 014 220 0201
CSGM-0.52	101 014 210 0501	CSGF-0.52	101 014 220 0501



# HMSB-024 Shielding Module

## Stamped contacts 5A

Contact resistance  $\leq 10\text{m}\Omega$

	Male	Order No.	Female	Order No.
silver plated 	CSSM-0.82P	101 014 110 0750	CSSF-0.82P	101 014 120 0750
gold plated 	CSGM-0.82P	101 014 210 0750	CSGF-0.82P	101 014 220 0750
coil stock 				

Note: 10kpcs/volume

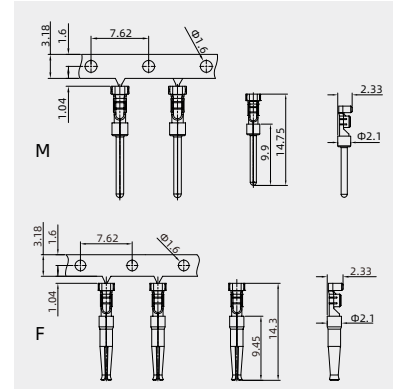

### Tools

	Wire gauge	Designation	Order No.
Crimping tool 	0.09-0.82mm <sup>2</sup>	TL03	198 001 001 0002

Notes: The tools for crimp terminal may influence the product quality and stability. Please select the tools recognized by our company.

## Cable clamp

### -Accessories for GigaBit, MegaBit and HMSB-024 shielding module

#### Technical characteristics

Specifications	DIN EN 60 664 DIN EN 61 984
Cable clamp	
Material	zinc alloy
Surface	passivated
Clamping range	5-14mm

#### Cable clamp



Clamping range	Designation	Order No.
5-7 mm	HM-CLP5-7	198 002 003 0031

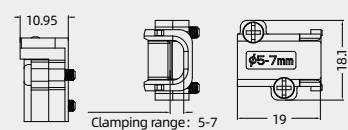

#### Cable clamp



Clamping range	Designation	Order No.
7-10 mm	HM-CLP7-10	198 002 003 0032

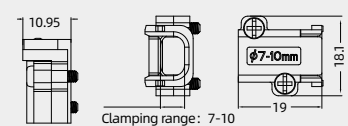

#### Cable clamp

Not applicable to HMMB with two outlet module



Clamping range	Designation	Order No.
9-11 mm	HM-CLP9-11	198 002 003 0037

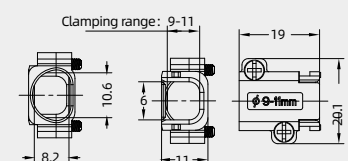

#### Cable clamp



Clamping range	Designation	Order No.
10-12 mm	HM-CLP10-12	198 002 003 0033

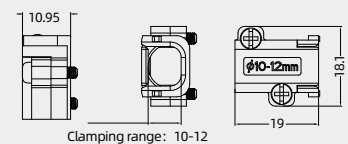

#### Cable clamp

Not applicable to HMMB with two outlet module



Clamping range	Designation	Order No.
11-14 mm	HM-CLP11-14	198 002 003 0044

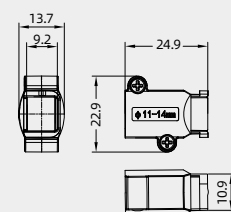

HM

# HMDS-009 D-Sub module - for one cable

50V 5A

Inserts



Combination with hinged frame and other modules possible.

## Technical characteristics

Specifications	DIN EN 60 664 DIN EN 61 984		
Approvals	VDE CE ENEC		
Inserts		Contacts	
Number of contacts	9	Material	copper alloy
Electrical data acc. to EN 61 984		Surface	hard-silver plated
-Rated current	5A		hard-gold plated
-Rated voltage	50V	Contact resistance	≤ 3mΩ
-Rated impulse voltage	0.8kV	Crimp terminal	
-Pollution degree	3	-mm <sup>2</sup>	0.09-0.82mm <sup>2</sup>
Insulation resistance	≥ 10 <sup>10</sup> Ω	-AWG	28-18
Material	polycarbonate		
Limiting temperatures	-40°C ...+125°C		
Flammability acc. to UL 94	V0		
Mechanical working life			
- mating cycles	≥ 500		

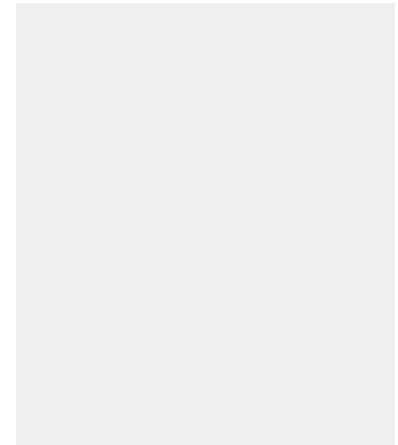

### Crimp terminal

Order crimp contacts separately



Insert	Description	Designation	Order No.
Male	for one cable	HMDS/2.1-009-MC	129 009 010 0101
Female	for one cable	HMDS/2.1-009-FC	129 009 020 0101

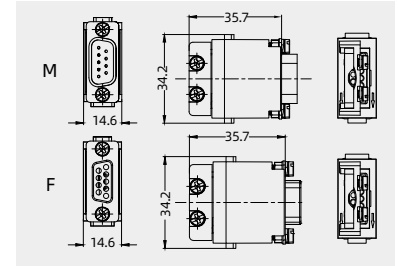

### Crimp terminal

Order crimp contacts separately



Insert	Description	Designation	Order No.
Male	for one cable	HMDS/2.1-009-MC 3SP01	129 009 010 0506
Female	for one cable	HMDS/2.1-009-FC 3SP01	129 009 020 0506

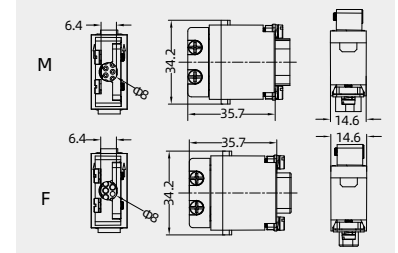

Clamp locking range: Φ 7mm

## Crimp contacts

### Crimp contacts 5A

Contact resistance ≤ 3mΩ  
silver plated

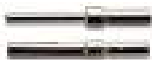

gold plated



Male	Order No.	Female	Order No.
CSSM-0.25	101 014 110 0101	CSSF-0.25	101 014 120 0101
CSSM-0.33	101 014 110 0201	CSSF-0.33	101 014 120 0201
CSSM-0.52	101 014 110 0501	CSSF-0.52	101 014 120 0501
CSSM-0.82	101 014 110 0701	CSSF-0.82	101 014 120 0701
CSGM-0.25	101 014 210 0101	CSGF-0.25	101 014 220 0101
CSGM-0.33	101 014 210 0201	CSGF-0.33	101 014 220 0201
CSGM-0.52	101 014 210 0501	CSGF-0.52	101 014 220 0501
CSGM-0.82	101 014 210 0701	CSGF-0.82	101 014 220 0701

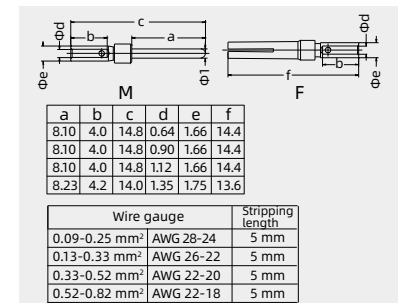

Notes: The tools for crimp terminal may influence the product quality and stability. Please select the tools recognized by our company.

HMDS-009 D-Sub module  
- for one cable

Stamped contacts 5A

Contact resistance  $\leq 10\text{m}\Omega$

silver plated



gold plated



coil stock



Note: 10kpcs/volume

Tools

Crimping tool



Contact removal tool



Male	Order No.	Female	Order No.
CSSM-0.82P	101 014 110 0750	CSSF-0.82P	101 014 120 0750
CSGM-0.82P	101 014 210 0750	CSGF-0.82P	101 014 220 0750

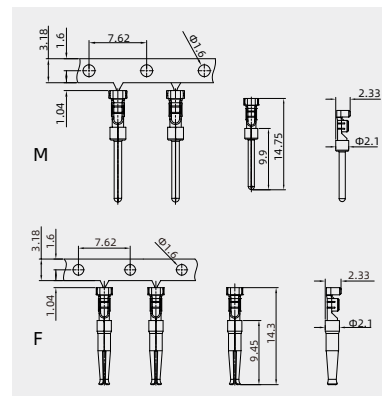

Wire gauge	Designation	Order No.
0.09-0.82mm <sup>2</sup>	TL03	198 001 001 0002
Application	Designation	Order No.
for 5A crimp contact	TL08	198 001 000 0006

Notes: The tools for crimp terminal may influence the product quality and stability. Please select the tools recognized by our company.

# HMDS-009 D-Sub module - for two cables

50V 5A

Inserts



Combination with hinged frame and other modules possible.

## Technical characteristics

Specifications	DIN EN 60 664 DIN EN 61 984		
Approvals			
Inserts		Contacts	
Number of contacts	9	Material	copper alloy
Electrical data acc. to EN 61 984		Surface	hard-silver plated
-Rated current	5A		hard-gold plated
-Rated voltage	50V	Contact resistance	≤ 3mΩ
-Rated impulse voltage	0.8kV	Crimp terminal	
-Pollution degree	3	-mm <sup>2</sup>	0.09-0.82mm <sup>2</sup>
Insulation resistance	≥ 10 <sup>10</sup> Ω	-AWG	28-18
Material	polycarbonate		
Limiting temperatures	-40°C ...+125°C		
Flammability acc. to UL 94	V0		
Mechanical working life			
- mating cycles	≥ 500		

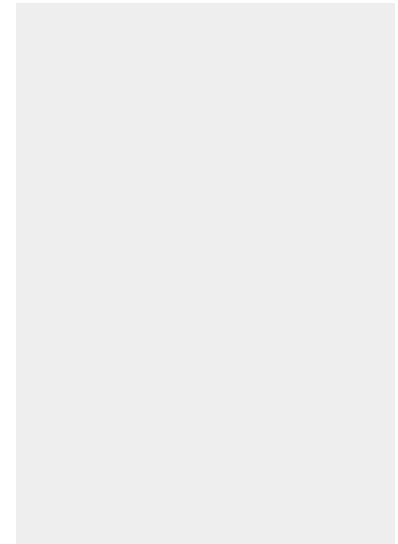

### Crimp terminal

Order crimp contacts separately

Insert	Description	Designation	Order No.
Male	for two cables	HMDS/2.2-009-MC	129 009 010 0102
Female	for two cables	HMDS/2.2-009-FC	129 009 020 0102

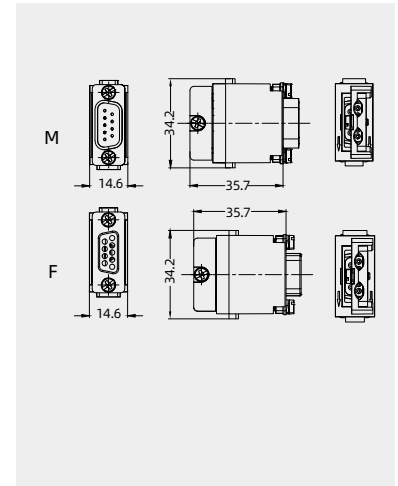

## Crimp contacts

Crimp contacts 5A

Contact resistance ≤ 3mΩ  
silver plated



gold plated



Male	Order No.	Female	Order No.
CSSM-0.25	101 014 110 0101	CSSF-0.25	101 014 120 0101
CSSM-0.33	101 014 110 0201	CSSF-0.33	101 014 120 0201
CSSM-0.52	101 014 110 0501	CSSF-0.52	101 014 120 0501
CSSM-0.82	101 014 110 0701	CSSF-0.82	101 014 120 0701
CSGM-0.25	101 014 210 0101	CSGF-0.25	101 014 220 0101
CSGM-0.33	101 014 210 0201	CSGF-0.33	101 014 220 0201
CSGM-0.52	101 014 210 0501	CSGF-0.52	101 014 220 0501
CSGM-0.82	101 014 210 0701	CSGF-0.82	101 014 220 0701

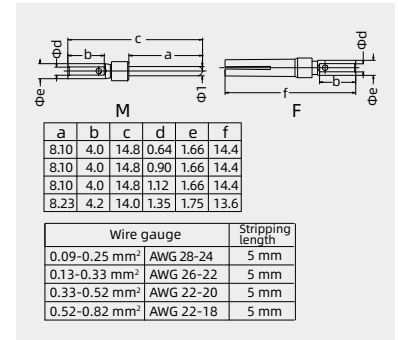

Notes: The tools for crimp terminal may influence the product quality and stability. Please select the tools recognized by our company.

HMDS-009 D-Sub module  
- for two cables

Stamped contacts 5A

Contact resistance  $\leq 10\text{m}\Omega$

silver plated



gold plated



coil stock



Note: 10kpcs/volume

Tools

Crimping tool



Contact removal tool



Male	Order No.	Female	Order No.
CSSM-0.82P	101 014 110 0750	CSSF-0.82P	101 014 120 0750
CSGM-0.82P	101 014 210 0750	CSGF-0.82P	101 014 220 0750

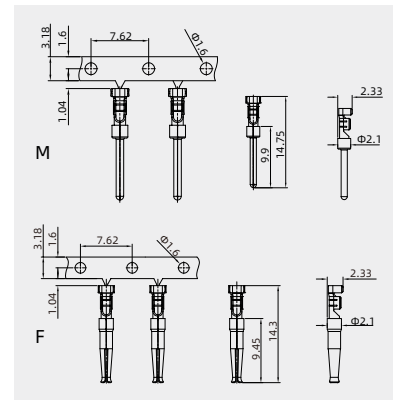

Wire gauge	Designation	Order No.
0.09-0.82mm <sup>2</sup>	TL03	198 001 001 0002
Application	Designation	Order No.
for 5A crimp contact	TL08	198 001 000 0006

Notes: The tools for crimp terminal may influence the product quality and stability. Please select the tools recognized by our company.

# HMDS-025 High Density module

50V 4A

Inserts



Combination with hinged frame and other modules possible.

## Technical characteristics

Specifications	DIN EN 60 664 DIN EN 61 984		
Approvals			
Inserts		Contacts	
Number of contacts	25	Material	copper alloy
Electrical data acc. to EN 61 984		Surface	hard-silver plated
-Rated current	4A		hard-gold plated
-Rated voltage	50V	Contact resistance	≤ 3mΩ
-Rated impulse voltage	0.8kV	Crimp terminal	
-Pollution degree	3	-mm <sup>2</sup>	0.09-0.52mm <sup>2</sup>
Insulation resistance	≥ 10 <sup>10</sup> Ω	-AWG	28-20
Material	polycarbonate		
Limiting temperatures	-40°C ... +125°C		
Flammability acc. to UL 94	V0		
Mechanical working life			
- mating cycles	≥ 500		

### Current carrying capacity

The current carrying is limited by maximum temperature of materials for inserts and contacts including terminals

Control and test procedures according to DIN EN 60512-5

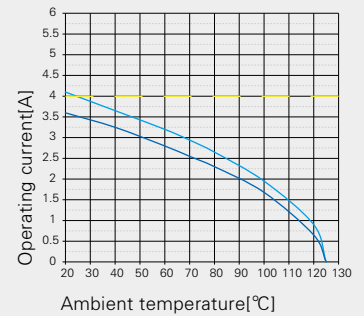

- 24 B hoods/housings with 6 modules, wire gauge: 0.5mm<sup>2</sup>(turned contacts)
- 24 B hoods/housings with 6 modules, wire gauge: 0.5mm<sup>2</sup>(stamped contacts)

### Crimp terminal

Order crimp contacts separately

Insert	Designation	Order No.
Male	HMDS-025-MC	129 025 010 0001
Female	HMDS-025-FC	129 025 020 0001

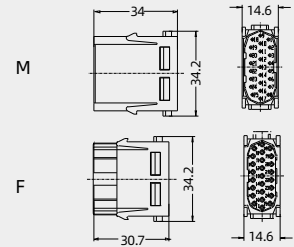

## Crimp contacts

### Crimp contacts 5A

Contact resistance ≤ 3mΩ  
silver plated



gold plated



Male	Order No.	Female	Order No.
CSSM-0.25	101 014 110 0101	CSSF-0.25	101 014 120 0101
CSSM-0.33	101 014 110 0201	CSSF-0.33	101 014 120 0201
CSSM-0.52	101 014 110 0501	CSSF-0.52	101 014 120 0501
CSGM-0.25	101 014 210 0101	CSGF-0.25	101 014 220 0101
CSGM-0.33	101 014 210 0201	CSGF-0.33	101 014 220 0201
CSGM-0.52	101 014 210 0501	CSGF-0.52	101 014 220 0501

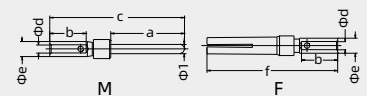

a	b	c	d	e	f
8.10	4.0	14.8	0.64	1.66	14.4
8.10	4.0	14.8	0.90	1.66	14.4
8.10	4.0	14.8	1.12	1.66	14.4

Wire gauge	Stripping length
0.09-0.25 mm <sup>2</sup>	AWG 28-24
0.13-0.33 mm <sup>2</sup>	AWG 26-22
0.33-0.52 mm <sup>2</sup>	AWG 22-20



# HMDS-025 High Density module

## Stamped contacts 5A

Contact resistance  $\leq 10m\Omega$

silver plated



gold plated



coil stock



Note: 10kpcs/volume

### Tools

Crimping tool



Contact removal tool



Male	Order No.	Female	Order No.
CSSM-0.82P	101 014 110 0750	CSSF-0.82P	101 014 120 0750
CSGM-0.82P	101 014 210 0750	CSGF-0.82P	101 014 220 0750

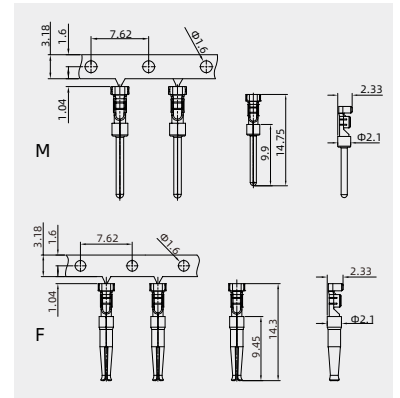

Wire gauge	Designation	Order No.
0.09-0.82mm <sup>2</sup>	TL03	198 001 001 0002
Application	Designation	Order No.
for 5A crimp contact	TL08	198 001 000 0006

Notes: The tools for crimp terminal may influence the product quality and stability. Please select the tools recognized by our company.

# HMDS-036 High Density module

32V 4A

Inserts



Combination with hinged frame and other modules possible.

## Technical characteristics

Specifications	DIN EN 60 664 DIN EN 61 984		
Approvals			
Inserts		Contacts	
Number of contacts	36	Material	copper alloy
Electrical data acc. to EN 61 984		Surface	hard-silver plated
-Rated current	4A		hard-gold plated
-Rated voltage	32V	Contact resistance	≤ 3mΩ
-Rated impulse voltage	0.8kV	Crimp terminal	
-Pollution degree	3	-mm <sup>2</sup>	0.09-0.52mm <sup>2</sup>
Insulation resistance	≥ 10 <sup>10</sup> Ω	-AWG	28-20
Material	polycarbonate		
Limiting temperatures	-40°C ...+125°C		
Flammability acc. to UL 94	V0		
Mechanical working life			
- mating cycles	≥ 500		

### Crimp terminal

Order crimp contacts separately



Insert	Designation	Order No.
Male	HMDS-036-MC	129 036 010 0001
Female	HMDS-036-FC	129 036 020 0001

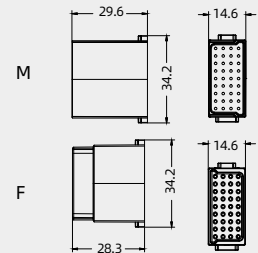

## Crimp contacts

Crimp contacts 5A

Contact resistance ≤ 3mΩ  
silver plated



gold plated



Male	Order No.	Female	Order No.
CSSM-0.25	101 014 110 0101	CSSF-0.25	101 014 120 0101
CSSM-0.33	101 014 110 0201	CSSF-0.33	101 014 120 0201
CSSM-0.52	101 014 110 0501	CSSF-0.52	101 014 120 0501
CSGM-0.25	101 014 210 0101	CSGF-0.25	101 014 220 0101
CSGM-0.33	101 014 210 0201	CSGF-0.33	101 014 220 0201
CSGM-0.52	101 014 210 0501	CSGF-0.52	101 014 220 0501

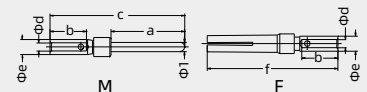

	a	b	c	d	e	f
8.10	4.0	14.8	0.64	1.66	14.4	
8.10	4.0	14.8	0.90	1.66	14.4	
8.10	4.0	14.8	1.12	1.66	14.4	

Wire gauge	Stripping length
0.09-0.25 mm <sup>2</sup>	AWG 28-24
0.13-0.33 mm <sup>2</sup>	AWG 26-22
0.33-0.52 mm <sup>2</sup>	AWG 22-20

Notes: The tools for crimp terminal may influence the product quality and stability. Please select the tools recognized by our company.

# HMDS-036 High Density module

## Stamped contacts 5A

Contact resistance  $\leq 10m\Omega$

silver plated



gold plated



coil stock



Note: 10kpcs/volume

### Tools

Crimping tool



Contact removal tool



Male	Order No.	Female	Order No.
CSSM-0.82P	101 014 110 0750	CSSF-0.82P	101 014 120 0750
CSGM-0.82P	101 014 210 0750	CSGF-0.82P	101 014 220 0750

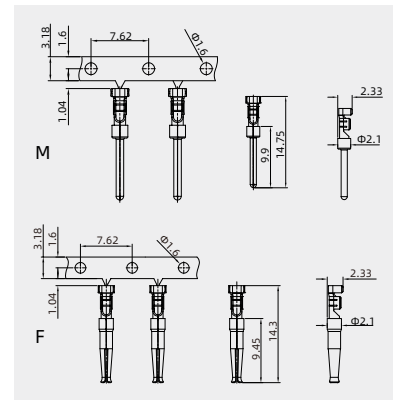

Wire gauge	Designation	Order No.
0.09-0.82mm <sup>2</sup>	TL03	198 001 001 0002
Application	Designation	Order No.
for 5A crimp contact	TL08	198 001 000 0006

Notes: The tools for crimp terminal may influence the product quality and stability. Please select the tools recognized by our company.

## HM-USB module

50V 1A

Inserts



Combination with hinged frame and other modules possible.

## Technical characteristics

Specifications	DIN EN 60 664 DIN EN 61 984
Approvals	ENEC
Inserts	
Number of contacts	4
Electrical data acc. to EN 61 984	
-Rated current	1A
-Rated voltage	50V
-Rated impulse voltage	0.8kV
-Pollution degree	3
Insulation resistance	< 30V
Material	$\geq 10^{10}\Omega$
Limiting temperatures	polycarbonate
Flammability acc. to UL 94	-40°C ...+85°C
Mechanical working life	V0
- mating cycles	$\geq 500$

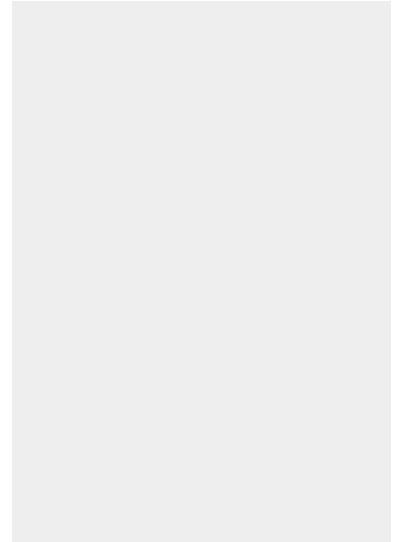

## Used to connect cables



Insert	Designation	Order No.
Male	HM-USB-M	129 001 001 0004
Female	HM-USB-F	129 001 002 0093

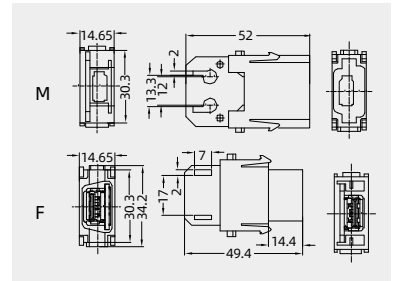

## HM-USB module

50V 1A

## Inserts



Combination with hinged frame and other modules possible.

## Technical characteristics

Specifications	DIN EN 60 664 DIN EN 61 984
----------------	--------------------------------

## Approvals

## Inserts

Number of contacts	8
Electrical data acc. to EN 61 984	
-Rated current	1A
-Rated voltage	50V
-Rated impulse voltage	0.8kV
-Pollution degree	3
Insulation resistance	< 30V
Material	$\geq 10^{10}\Omega$
Limiting temperatures	polycarbonate
Flammability acc. to UL 94	-40°C ... +85°C
Mechanical working life	V0
- mating cycles	$\geq 3000$

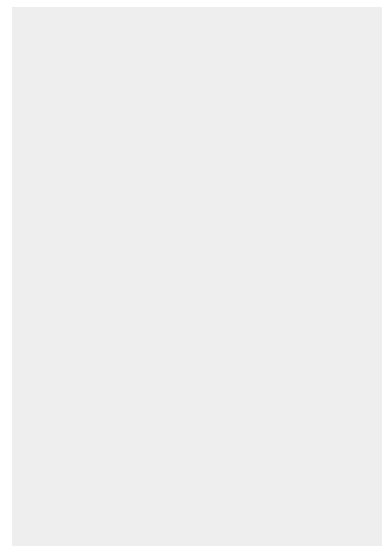

## Used to connect cables



Insert	Designation	Order No.
Female	HM-USB3.0-F	129 000 002 0002

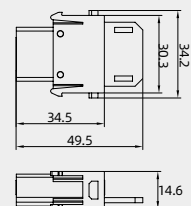

# HM-RJ45 module

50V 1A

## Inserts



Male inserts only suitable for high structure shells. Combination with hinged frame and other modules possible.

## Technical characteristics

Specifications	DIN EN 60 664 DIN EN 61 984
Approvals	ENEC
Inserts	
Number of contacts	8
Electrical data acc. to EN 61 984	
-Rated current	1A
-Rated voltage	50V
-Rated impulse voltage	0.8kV
-Pollution degree	3
Rated voltage acc. to UL	< 30 V
Transmission features	Category 6 /Class E up to 500 MHz; acc. to ISO/IEC 11 801:2002 and EN 50 173-1
Transmission rate	10/100/1000Mbit/10Gbit/s
Insulation resistance	≥ 10 <sup>10</sup> Ω
Material	polycarbonate
Limiting temperatures	-40°C ...+85°C
Flammability acc. to UL 94	V0
Mechanical working life	
- mating cycle	≥ 500

### Inserts for patch cable



Insert	Designation	Order No.
Male	HM-RJ45-M	229 001 001 0001
Female	HM-RJ45-F	129 001 002 0092

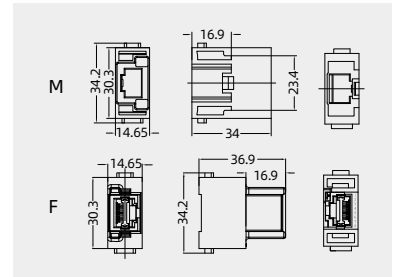

### Adapter



Insert	Designation	Order No.
go with male insert for standard cable	HM-RJ45-APT/2	229 001 000 0005

Please refer to page 10-50 for matching cable (no plastic cable)  
go with male insert: HM-RJ45-M/APT/2 129 001 001 0002

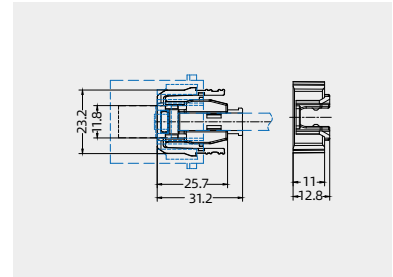

## HM

### Adapter



Description	Designation	Order No.
go with male insert for standard cable	HM-RJ45-APT	229 001 000 0003

Please refer to page 10-50.1 for matching cable  
go with male insert: HM-RJ45-M/APT 129 001 001 0001

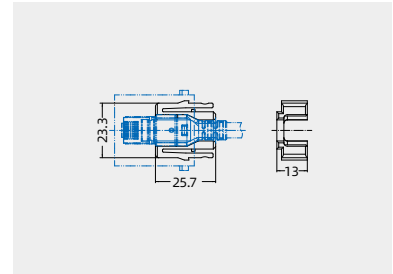

## HM-RJ45 module

50V 1A

## Inserts

## Technical characteristics

Specifications	DIN EN 60 664 DIN EN 61 984
Approvals	
Inserts	
Number of contacts	8
Electrical data acc. to EN 61 984	
-Rated current	1A
-Rated voltage	50V
-Rated impulse voltage	0.8kV
-Pollution degree	3
Rated voltage acc. to UL	< 30 V
Transmission features	Category 6 /Class E up to 500 MHz; acc. to ISO/IEC 11 801:2002 and EN 50 173-1
Transmission rate	10/100/1000Mbit/10Gbit/s
Insulation resistance	$\geq 10^{10} \Omega$
Material	polycarbonate
Limiting temperatures	-40°C ...+85°C
Flammability acc. to UL 94	V0
Mechanical working life	
- mating cycle	$\geq 500$

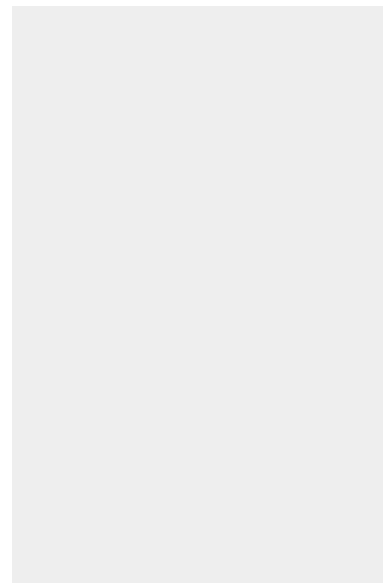

## Inserts for patch cable

Insert	Designation	Order No.
	HM-RJ45-M/F	198 002 009 0001



Transmission features: Category 6 /Class E up to 500 MHz

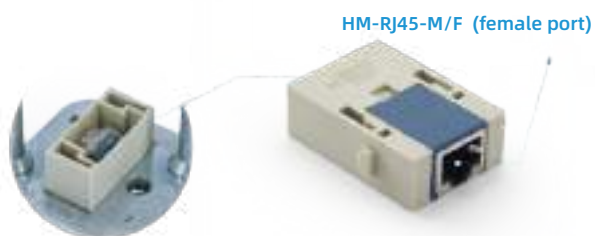
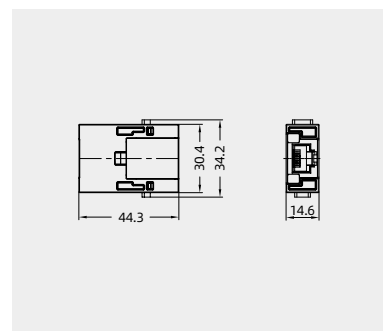

HM-RJ45-M/F (male port)

HM-RJ45-M/F (female port)

### Characteristics

- Preset Registered jack, no need for on-site crimping and assembly
- The male module does not require additional adapter assembly
- Suitable for WAIN standard framework or single module framework
- Transmission features: Category 6 /Class E up to 500 MHz

## HM-RJ45 Patch cables

50V 1A

### Technical characteristics

Specifications	ISO/IEC 24 702 ISO/IEC 11 801 ISO/IEC 61 935-2	
Cat.5 e RJ45 Patch cables	Cat.6A RJ45 Patch cables	
Transmission features	Category 5 /Class D up to 100 MHz;acc. to ISO/IEC 24 702 or ISO/IEC 11 801	Transmission features Category 6 /Class D up to 500 MHz;acc. to ISO/IEC 24 702 or ISO/IEC 11 801
Transmission rate	10/100/1000 Mbit/s	Transmission rate 10/100/1000 Mbit/10Gbit/s
Cable type	1:1 EIA/TIA 568 B, 8 poles	Cable type EIA/TIA 568 B,8 poles
Material cables	SF/UTP, PVC, blue	Material cables S/FTP,PUR,Water blue
Limiting temperatures	Limiting temperatures	
- mobile	0°C ...+60°C	- mobile 0°C ...+60°C
- stationary	-40°C ...+80°C	- stationary -40°C ...+80°C
Flammability	Flammability lame retardant,halogen-free	
Degree of protection	IP20	Degree of protection IP20

### Assembly diagram

HM-RJ45-APT/2



### Standard cable<sup>1)</sup>

1) Further cable length upon request.



Length(L)	Designation	Order No.
1.5m	PC/2-RJ45-1.5(Cat.5e)	906 010 000 0048
2m	PC/2-RJ45-2.0(Cat.5e)	906 010 000 0049
3m	PC/2-RJ45-3.0(Cat.5e)	906 010 000 0050
4m	PC/2-RJ45-4.0(Cat.5e)	906 010 000 0051
5m	PC/2-RJ45-5.0(Cat.5e)	906 010 000 0052
7m	PC/2-RJ45-7.0(Cat.5e)	906 010 000 0053
9m	PC/2-RJ45-9.0(Cat.5e)	906 010 000 0054
10m	PC/2-RJ45-10.0(Cat.5e)	906 010 000 0055

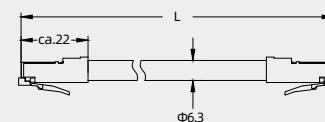

### Standard cable<sup>1)</sup>

1) Further cable length upon request.



Length(L)	Designation	Order No.
1.5m	PC/2-RJ45-1.5(Cat.6A)-PUR	198 002 010 0005
2m	PC/2-RJ45-2.0(Cat.6A)-PUR	198 002 010 0006
3m	PC/2-RJ45-3.0(Cat.6A)-PUR	198 002 010 0007
4m	PC/2-RJ45-4.0(Cat.6A)-PUR	198 002 010 0008

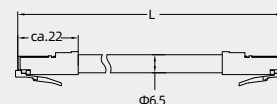



# HM-RJ45 Patch cables

50V 1A

## Technical characteristics

Specifications	ISO/IEC 24 702 ISO/IEC 11 801 ISO/IEC 61 935-2	
Cat.6A RJ45 Patch cables		Assembly diagram HM-RJ45-APT
Transmission features	Category 6 /Class D up to 500 MHz;acc. to ISO/IEC 24 702 or ISO/IEC 11 801	
Transmission rate	10/100/1000 Mbit/10Gbit/s	
Cable type	EIA/TIA 568 B,8 poles	
Material cables	S/FTP,PUR,Water blue	
Limiting temperatures		
- mobile	0°C ...+60°C	
- stationary	-40°C ...+80°C	
Flammability	flame retardant, halogen-free	
Degree of protection	IP20	

### Standard cable<sup>1)</sup>

1) Further cable length upon request.



Length(L)	Designation	Order No.
0.5m	2RJ45-M08-T-0.5-PUR-Cat.6a	172 008 401 4026
1.0m	2RJ45-M08-T-1.0-PUR-Cat.6a	172 008 401 4020
1.5m	2RJ45-M08-T-1.5-PUR-Cat.6a	172 008 401 4027
2m	2RJ45-M08-T-2.0-PUR-Cat.6a	172 008 401 4019
3m	2RJ45-M08-T-3.0-PUR-Cat.6a	172 008 401 4025
4m	2RJ45-M08-T-4.0-PUR-Cat.6a	172 008 401 4021
7m	2RJ45-M08-T-7.0-PUR-Cat.6a	172 008 401 4018

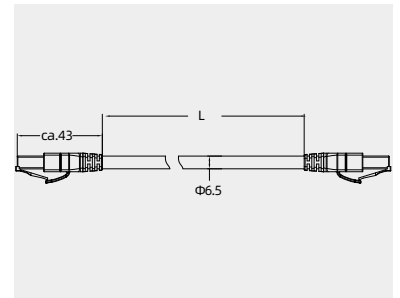

# HMP-002 Pneumatic module



Combination with hinged frame and other modules possible.

## Inserts

### Technical characteristics

Specifications	DIN EN 60 664 DIN EN 61 984		
Approvals			
Inserts	Contacts		
Number of contacts	2	Material	delrin acetal
Colour	blue	Colour	black
Material	polycarbonate	Tube termination	
Limiting temperatures	-40°C ...+80°C	- Internal diameter (ID)	6.0mm / 1/4 "
Flammability acc. to UL 94	V0	Working pressure	up to 8 bar / 116 psi
Mechanical working life		Sealing	
- mating cycles	≥ 500	-Material	FPM
		Shut off valve	
		-Material	polyformaldehyde

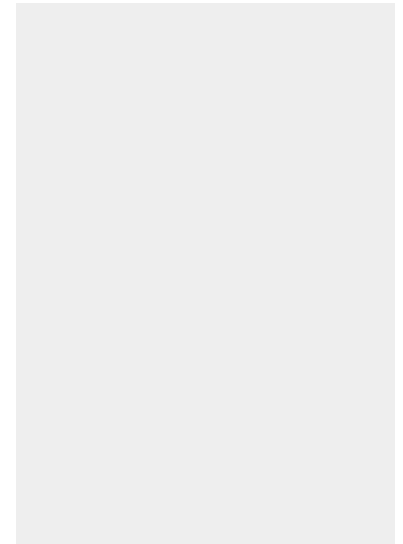

### Pneumatic module

Order contacts separately



Description	Designation	Order No.
for 6 mm	HMP-002	129 002 000 0001

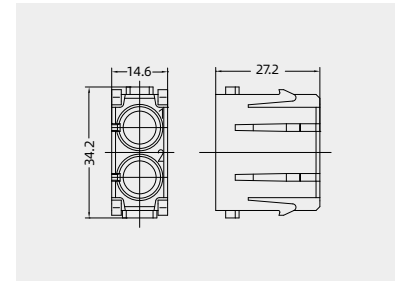

## Contacts

### Pneumatic contacts

for tube internal diameter(ID)



Description	Category	ID	Designation	Order No.
without shut off Male		6.0mm	PCM-6.0	101 100 001 0004
without shut off Female		6.0mm	PCF-6.0	101 100 002 0004

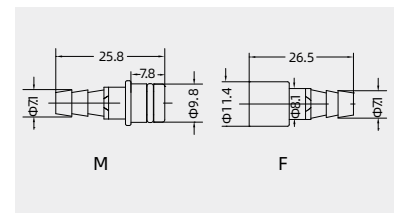

### Pneumatic contacts

for tube internal diameter(ID)



Description	Category	ID	Designation	Order No.
with shut off Female		6.0mm	PCFS-6.0	101 100 002 0014

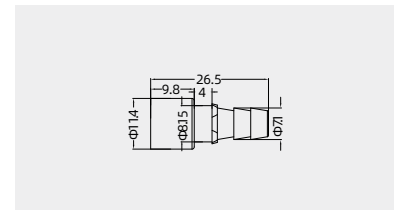



Combination with hinged frame and other modules possible.

Inserts

Technical characteristics

Specifications	DIN EN 60 664 DIN EN 61 984		
Approvals			
Inserts	Contacts		
Number of contacts	3	Material	polyformaldehyde
Colour	blue	Colour	black
Material	polycarbonate	Tube termination	
Limiting temperatures	-40°C ...+80°C	- Internal diameter (ID)	1.6mm / 1/16 "
Flammability acc. to UL 94	V0		3.0mm
Mechanical working life			4.0mm / 1/8 "
- mating cycles	≥ 500	Working pressure	up to 8 bar / 116 psi
		Sealing	
		-Material	FPM
		Shut off valve	
		-Material	polyformaldehyde

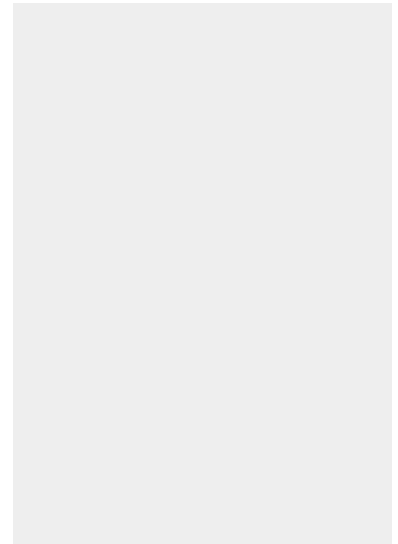

Pneumatic module  
Order contacts separately



Insert	Designation	Order No.
HMP-003		129 003 000 0001

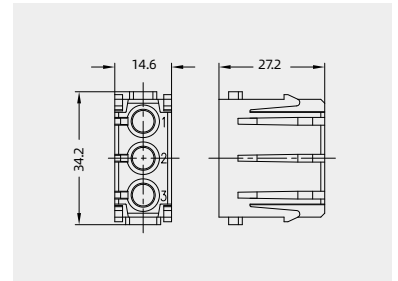

Contacts

Pneumatic contacts  
for tubeinternal diameter(ID)



Description	Category	ID	Designation	Order No.
without shut off	Male	1.6 mm	PCM-1.6	101 100 001 0001
		3.0 mm	PCM-3.0	101 100 001 0002
		4.0 mm	PCM-4.0	101 100 001 0003
without shut of	Female	1.6 mm	PCF-1.6	101 100 002 0001
		3.0 mm	PCF-3.0	101 100 002 0002
		4.0 mm	PCF-4.0	101 100 002 0003

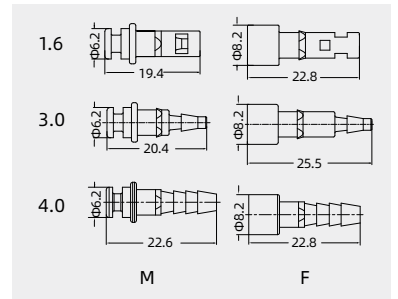

Pneumatic contacts  
for tubeinternal diameter(ID)



Description	Category	ID	Designation	Order No.
with shut off	Female	1.6 mm	PCFS-1.6	101 100 002 0011
		3.0 mm	PCFS-3.0	101 100 002 0012
		4.0 mm	PCFS-4.0	101 100 002 0013

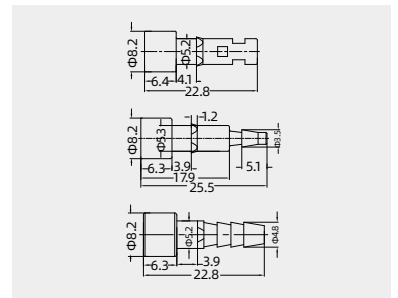

# HMP-003 Metal Pneumatic Module



Combination with hinged frame and other modules possible.

## Inserts

### Technical characteristics

Specifications	DIN EN 60 664 DIN EN 61 984		
Approvals			
Inserts	Contacts		
Number of contacts	3	Material	copper
Material	polycarbonate	Colour	nickel plating
Limiting temperatures	-40°C ... +80°C	Tube termination	
Flammability acc. to UL 94	V0	- Outer diameter (OD)	3.0mm / 4.0mm / 6.0mm
Mechanical working life		Working pressure	up to 10 bar / 145 psi
- mating cycles	≥ 500	Sealing	
		-Material	FPM
		Shut off valve	
		-Material	polyformaldehyde

Metal Pneumatic Module  
Order contacts separately



Insert	Designation	Order No.
	HMP-003-V2	129 003 000 0505

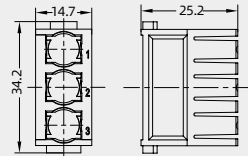

## Contacts

Metal Pneumatic Contacts

Used for Flexible Tube(OD)



Description	Category	OD	Designation	Order No.
without shut off	Male	3.0mm	MPCM-OD3.0	101 100 001 0005
		4.0mm	MPCM-OD4.0	101 100 001 0006
		6.0mm	MPCM-OD6.0	101 100 001 0007
without shut off	Female	3.0mm	MPCF-OD3.0	101 100 002 0017
		4.0mm	MPCF-OD4.0	101 100 002 0019
		6.0mm	MPCF-OD6.0	101 100 002 0021

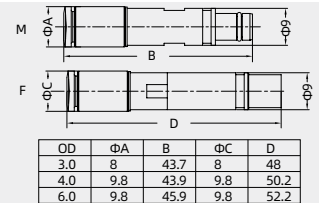

Metal Pneumatic Contacts

Used for Flexible Tube(OD)



Description	Category	OD	Designation	Order No.
with shut off	Female	3.0mm	MPCFS-OD3.0	101 100 002 0016
		4.0mm	MPCFS-OD4.0	101 100 002 0018
		6.0mm	MPCFS-OD6.0	101 100 002 0020

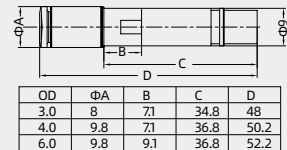

Tools

Contact removal tool



Application	Designation	Order No.
for HMP-003-V2 Metal Pneumatic Module	TL26	198 001 000 0030



Combination with hinged frame and other modules possible.

## Inserts

### Technical characteristics

Specifications	DIN EN 60 664 DIN EN 61 984		
Approvals			
Inserts			
Number of contacts	3	Contacts	
Material	polycarbonate	Material	copper
Limiting temperatures	-40°C ...+80°C	Colour	nickel plating
Flammability acc. to UL 94	V0	Tube termination	
Mechanical working life		- Internal diameter (ID)	3.0mm / 4.0mm / 6.0mm
- mating cycles	≥ 500	Working pressure	up to 10 bar / 145 psi
		Sealing	
		-Material	FPM
		Shut off valve	
		-Material	polyformaldehyde

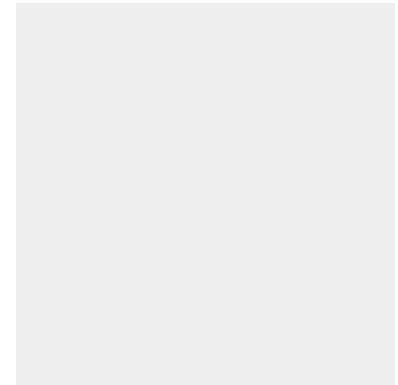

Metal Pneumatic Module  
Order contacts separately



Insert	Designation	Order No.
	HMP-003-V2	129 003 000 0505

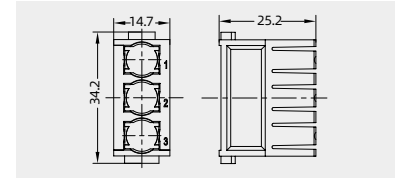

## Contacts

Metal Pneumatic Contacts

Used for Flexible Tube(ID)



Description	Category	ID	Designation	Order No.
without shut off	Male	3.0mm	MPCM-ID3.0	101 100 001 1102
		4.0mm	MPCM-ID4.0	101 100 001 1201
		6.0mm	MPCM-ID6.0	101 100 401 1301
without shut off	Female	3.0mm	MPCF-ID3.0	101 100 002 1102
		4.0mm	MPCF-ID4.0	101 100 002 1202
		6.0mm	MPCF-ID6.0	101 100 402 1302

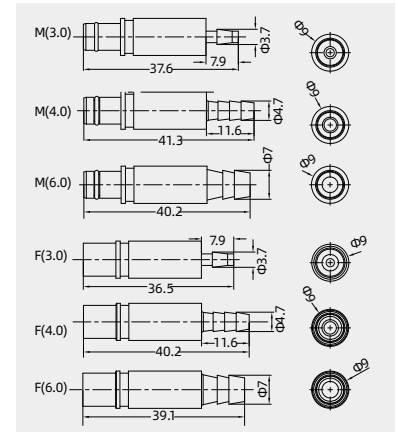

Metal Pneumatic Contacts

Used for Flexible Tube(ID)



Description	Category	ID	Designation	Order No.
with shut off	Male	6.0mm	MPCMS-ID6.0	101 100 400 1301
with shut off	Female	3.0mm	MPCFS-ID3.0	101 100 002 1101
		4.0mm	MPCFS-ID4.0	101 100 002 1201
		6.0mm	MPCFS-ID6.0	101 100 402 1301

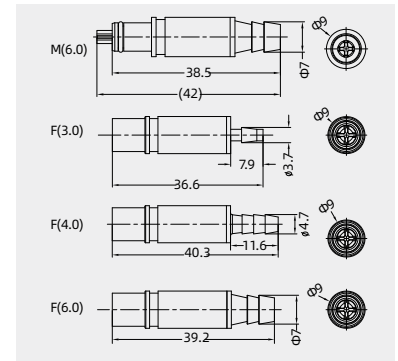

Tools

Contact removal tool



Application	Designation	Order No.
for HMP-003-V2 Metal Pneumatic Module	TL26	198 001 000 0030

HM

# HMSC-004 SC Fiber module



Combination with hinged frame and other modules possible.

## Inserts

### Technical characteristics

Specifications	DIN EN 60 664
	DIN EN 61 984

#### Approvals

Inserts	
Number of contacts	4
Insertion loss	< 0.5 dB
Material polycarbonate	polycarbonate
Limiting temperatures	-40 ° C ... +85 ° C
Flammability acc. to UL 94	V 0
Mechanical working life	
- mating cycles	≥ 500

#### Assembly instructions

**HMSC-004-MC**

Assemble the SC contact  
Push the SC contact from the side into the relevant insert (1)  
Push the fixing plate from the side over the contacts (2)  
B: SC contact fixed in the module

**HMSC-004-MC**

Assemble the SC contact  
Push the centering ferrule (included in delivery) on the SC contact (1)  
Push the SC contact from the side into the relevant insert (2)  
Push the fixing plate from the side over the contacts (3)  
B: SC contact fixed in the module

### SC module

Order SC Optical fiber connector separately



Insert	Designation	Order No.
Male	HMSC-004-MC	129 004 010 0091
Female	HMSC-004-FC	129 004 020 0091

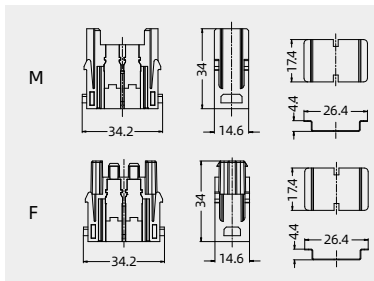

### SC Optical fiber connector<sup>1)</sup>

SC Optical fiber connector  
single mode: 9/125µm ,for GI fibre



Describtion	Designation	Order No.
Spare parts <sup>2)</sup>	SC-PC/SM-3.0	295 000 001 0002
Fiber jumper	PC-SC/UPC-SC/UPC-1.0(9/125µm-φ3.0)	906 010 000 0099
	PC-SC/UPC-SC/UPC-2.0(9/125µm-φ3.0)	906 010 000 0100

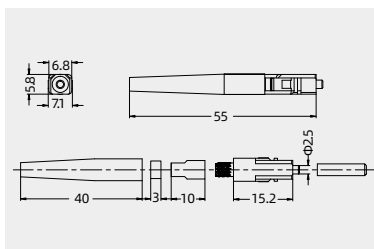

SC Optical fiber connector  
multimode: 50/125µm or 62.5/125µm,  
for GI fibre



Describtion	Designation	Order No.
Spare parts <sup>2)</sup>	SC-PC/MM-3.0	295 000 001 0001
Fiber jumper	PC-SC/UPC-SC/UPC-1.0(50/125µm-φ3.0)	906 010 000 0097
	PC-SC/UPC-SC/UPC-2.0(50/125µm-φ3.0)	906 010 000 0098
	PC-SC/UPC-SC/UPC-1.0(62.5/125µm-φ3.0)	906 010 000 0095
	PC-SC/UPC-SC/UPC-2.0(62.5/125µm-φ3.0)	906 010 000 0096

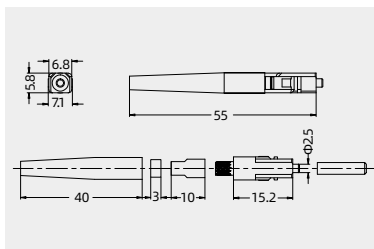

1) SC, FC, ST, LC, MTRJ, different specifications and lengths of fiber optic jumper can be customized  
2) Order spare parts should be equipped with corresponding equipment

# HASC-004 SC Fiber module

Hoods/Housings: **size 3A with sealing**, please find the details on page 15-54~15-60.  
cannot match the metal hood: HP3A/H-BK-SE, HP3A/H-SF-2H-M20,HP3A/H-SF-2H-PG13.5,HP3A/H-SF-2H

## Inserts

### Technical characteristics

Specifications	DIN EN 60 664 DIN EN 61 984
<b>Approvals</b>	
<b>Inserts</b>	
Number of contacts	4
Insertion loss	< 0,5 dB
Material polycarbonate	polycarbonate
Limiting temperatures	-40 ° C ... +85 ° C
Flammability acc. to UL 94	V 0
Mechanical working life	
- mating cycles	≥ 500
• Degree of protection up to IP 65/IP68	
• For WAIN fibre optic SC Optical fiber connector ;	
up to 4 SC Optical fiber connector	
• For Multimode fibre 50 - 62.5 / 125 µm and	
Singlemode fibre 9 / 125 µm	

<b>Assembly instructions</b>	
HASC-004-MC	 <p>Assemble the SC contact (1) Push the SC contact from the side into the relevant insert (2) Push the spring clip over the contact body.</p>
HASC-004-FC	 <p>Assemble the SC contact (1) Push the centering ferrule (included in delivery) on the SC contact (2) Push the SC contact from the side into the relevant insert (3) Push the spring clip over the contact body.</p>

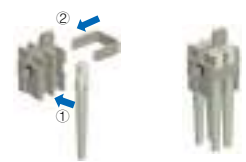
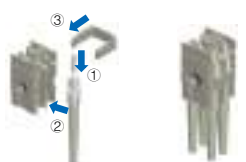

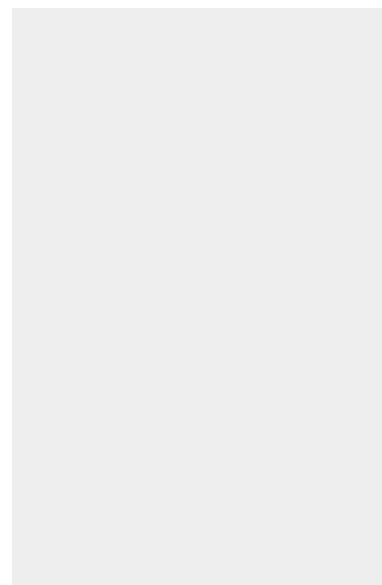
### SC module

Order SC Optical fiber connector separately



Insert	Designation	Order No.
Male	HASC-004-MC	121 004 010 0001
Female	HASC-004-FC	121 004 020 0001

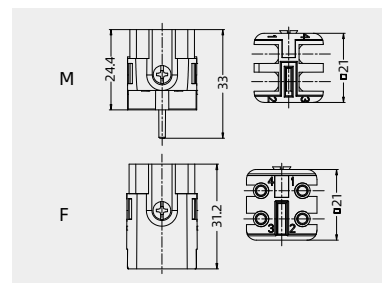

### SC Optical fiber connector<sup>1)</sup>

SC Optical fiber connector  
single mode: 9/125µm ,for GI fibre



Describtion	Designation	Order No.
Spare parts <sup>2)</sup>	SC-PC/SM-3.0	295 000 001 0002
Fiber jumper	PC-SC/UPC-SC/UPC-1.0(9/125µm-φ3.0)	906 010 000 0099
	PC-SC/UPC-SC/UPC-2.0(9/125µm-φ3.0)	906 010 000 0100

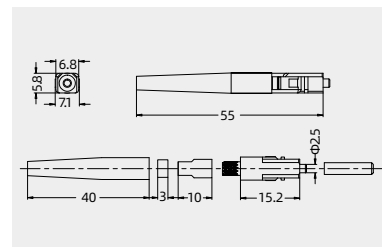

SC Optical fiber connector  
multimode: 50/125µm or 62.5/125µm,  
for GI fibre



Describtion	Designation	Order No.
Spare parts <sup>2)</sup>	SC-PC/MM-3.0	295 000 001 0001
Fiber jumper	PC-SC/UPC-SC/UPC-1.0(50/125µm-φ3.0)	906 010 000 0097
	PC-SC/UPC-SC/UPC-2.0(50/125µm-φ3.0)	906 010 000 0098
	PC-SC/UPC-SC/UPC-1.0(62.5/125µm-φ3.0)	906 010 000 0095
	PC-SC/UPC-SC/UPC-2.0(62.5/125µm-φ3.0)	906 010 000 0096

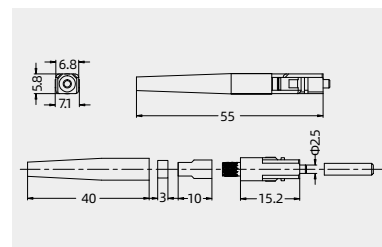

1) SC, FC, ST, LC, MTRJ, different specifications and lengths of fiber optic jumper can be customized  
2) Order spare parts should be equipped with corresponding equipment

# H3A RJ45

125V AC 1.5A Combination of RJ45 and H3A Hoods/Housings

## Inserts

### Technical characteristics

Specifications	ISO/IEC 11 801:2002 EN 50 173-1		
Inserts	Hoods/Housings		
Number of contacts	8	Material	Zinc alloy, SprayingRAL7037
Transmission performance	Category 5 /Class E up to100 MHz acc. to ISO/IEC 11 801:2002, EN 50 173-1	Degree of protection	IP65
Transmission rate	10/100 Mbit/s, 1 Gbit/s		
Shielding	fully shielded, 360° shielding contact		
Cable termination	with piercing		
Limiting temperatures	-40°C ... +70°C		
Mechanical working life			
- mating cycle	≥ 500		

#### H3A RJ45 With cable gland



Insert	Designation	Order No.
Male	H3A-TE/S-2B-PG11-RJ45/M	110 003 410 1191
	H3A-TE/S-2B-M20-RJ45/M	110 003 400 1192
Female	H3A-BK-1L/W-RJ45/F	110 003 324 1091
	H3A-BK-1L/W-MCV-RJ45/F	110 003 324 1092

#### H3A RJ45, side entry, With cable gland



Insert	Designation	Order No.
Male	H3A-SE/S-2B-PG11-RJ45/M	110 003 510 1191
	H3A-SE/S-2B-M20-RJ45/M	110 003 510 1192

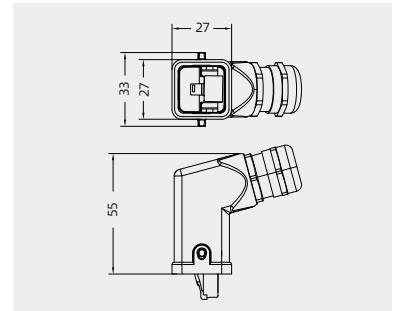
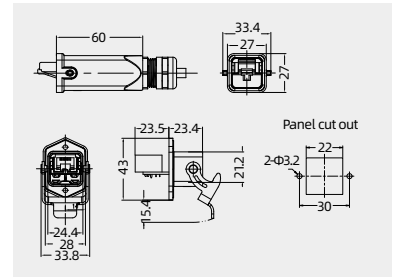
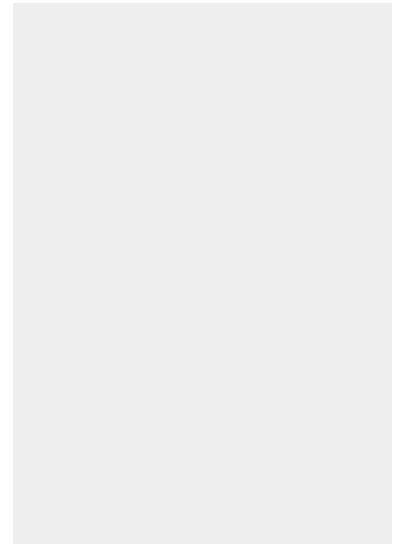



## Structural characteristics and assembly instruction

### Functional characteristics:

- ① Compatible with standard shielding CAT5 RJ45 connector on the market;
- ② Coding pin provides coding function.

### Innovation:

- ① The boss of male adapter 1 positioned together with the groove of network cable of ordinary shielding RJ45;
- ② Male adapter has groove to fix the network cable;
- ③ Male adapter 1 and male adapter 2 cooperate by a hook;
- ④ Coding pin provides coding function.

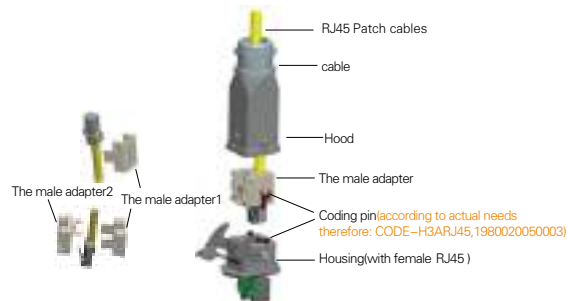

### Assembly instructions:

- Step 1: Put one end of the network cable through the cable gland, strip length is about 15 mm, straighten the cable;
- Step 2: Use the wire crimper to connect the cable and the crystal head;
- Step 3: Install the crystal head in the adapter;
- Step 4: Lock the adapter in the hood with a screwdriver (Torque 0.5 N.M), lock the cable gland with a wrench. If needed, a coding pin can also be used, and be careful about the mating of the hood and the housing, and the installation direction of the coding pin;
- Step 5: Lock the hood and the housing with the lever.

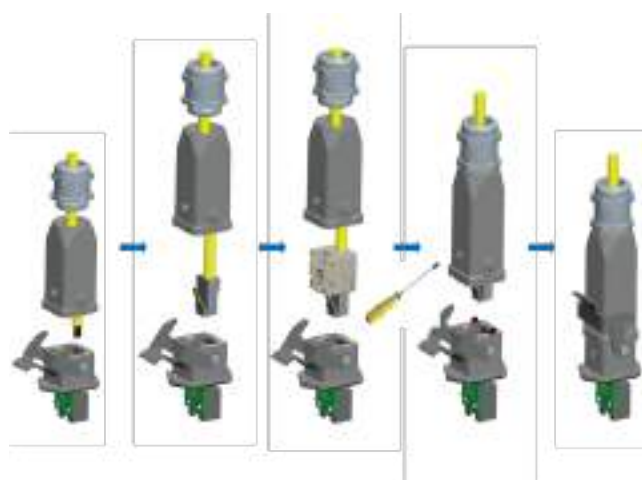

## H3A RJ45

125V AC 1.5A Combination of RJ45 and H3A Hoods/Housings

## Inserts

## Technical characteristics

Specifications ISO/IEC 11 801:2002  
EN 50 173-1

Inserts		Hoods/Housings	
Number of contacts	8	Material	Zinc alloy, Spraying RAL7037
Transmission performance	Category 6 /Class D up to 500MHZ acc. ISO/IEC 11 801:2002, EN 50 173-1	Degree of protection	IP65
Transmission rate	10/100/1000Mbit/10Gbit/s		
Shielding	fully shielded, 360° shielding contact		
Wire termination	By piercing the contact		
Limiting temperatures	-40°C ... +85°C		
Mechanical working life			
- mating cycle	≥ 500		

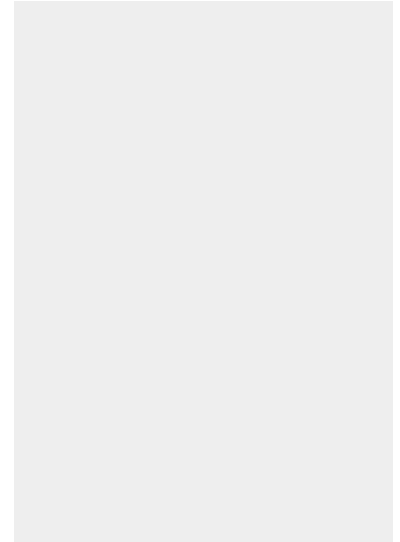

## H3A RJ45, top entry, With cable gland



Insert	Designation	Order No.
Male	H3A-TE/S-2B-PG11-RJ45/M-cat.6a	121 000 099 0500
	H3A-TE/S-2B-M20-RJ45/M-cat.6a	121 000 099 0501

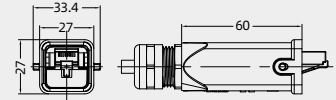

## H3A RJ45 With cable gland



Insert	Designation	Order No.
Female	H3A-BK-1L/W-RJ45/F-cat.6a	121 000 099 0502
	H3A-BK-1L/W-MCV-RJ45/F-cat.6a	121 000 099 0503

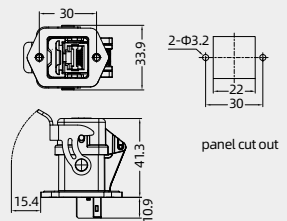
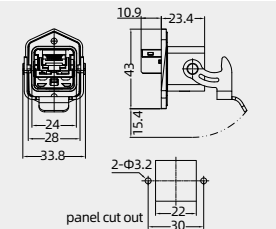

HM

## H3A RJ45, side entry, With cable gland



Insert	Designation	Order No.
Male	H3A-SE/S-2B-M20-RJ45/M-cat.6a	110 003 515 1500

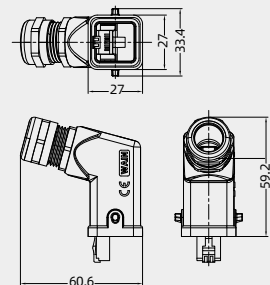

## H3A RJ45

## 48V 16A Combination of RJ45 and H3A Hoods/Housings

## Inserts

## Technical characteristics

Specifications	ISO/IEC 11 801:2002 EN 50 173-1	
Inserts(male)	Inserts(female)	
Number of contacts	4( data) + 4( power)	Number of contacts 8( data) + 4( power)
Transmission performance	Category 5 /Class E up to 100 MHz acc. to ISO/IEC 11 801:2002, EN 50 173-1	Transmission performance Category 6 /Class D up to 500MHZ acc. ISO/IEC 11 801:2002, EN 50 173-1
Transmission rate	10/100Mbit/s	Transmission rate 10/100/1000Mbit/10Gbit/s
Shielding	fully shielded,360°	Shielding fully shielded,360° shielding contact
Wire termination	Puncture contact(data), IDC puncture(power)	Terminal spring terminal(power)
Cable diameter	6...12mm	Pulse withstand voltage 800V
Rated voltage	48V	Rated voltage 48V
Rated current	16A	Rated current 16A
conductor cross-section	24AWG..22AWG(data), 16AWG(power)	conductor cross-section 22AWG..12AWG(power), 0.34...4.0mm <sup>2</sup> (power)
	0.22...0.32mm <sup>2</sup> (data), 1.5mm <sup>2</sup> (power)	Limiting temperatures -40°C ...+70°C
Limiting temperatures	-40°C ...+70°C	Mechanical working life - mating cycle ≥ 500
Mechanical working life - mating cycle	≥ 500	
Hoods/Housings		
Material	Zinc alloy,SprayingRAL7037	
Degree of protection	IP65	

## H3A RJ45 With cable gland



Insert	Designation	Order No.
male	H3A-TE/S-2B-M20-004/RJ45-M	121 008 001 0501
female	H3A-BK-1L/W-004/RJ45-F	121 008 002 0501

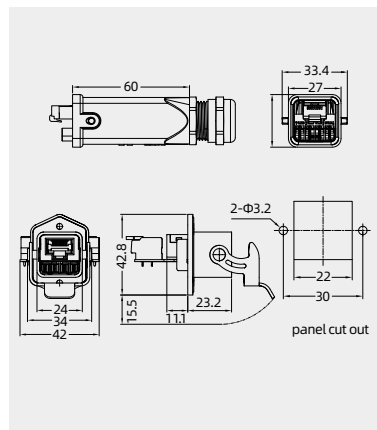

# Q-Coax Electromagnetic screening module



## Technical characteristics

Specifications	DIN EN 60 664 DIN EN 61 984
Approvals	UL C E FCC
Inserts	
Number of contacts	1,2
Insulation resistance	$\geq 10^{10}\Omega$
Material	polycarbonate
Limiting temperatures	-40°C ...+125°C
Flammability acc. to UL 94	V0
Mechanical working life(mating cycles)	$\geq 500$
Q-Coax contacts	
Number of contacts	
- Q-Coax	4 + shielding
- High Density Q-Coax	8 + shielding
Electrical data acc. to EN 61 984	
- Q-Coax	10A 50V 0.8kV 3
- High Density Q-Coax	5A 50V 0.8kV 3
Rated current	10/5A
Rated voltage	50V
Rated impulse voltage	0.8kV
Pollution degree	3
Material	
- Insulator	polycarbonate
- Outer conductor	zinc alloy
Contact resistance	$\leq 4m\Omega$
Limiting temperatures	-40°C ...+85°C
Flammability acc. to UL 94	V0
Outer surface finish	nickel
Cable diameter	3-9.5mm
D-Sub crimp contacts(5A)	
Material	copper alloy
Surface	hard-gold plated
Contact resistance	$\leq 3m\Omega$
Crimp terminal	
-mm <sup>2</sup>	0.09-0.52mm <sup>2</sup>
-AWG	28-20
D contacts(10A)	
Material	copper alloy
Surface	hard-gold plated
Contact resistance	$\leq 3m\Omega$
Crimp terminal	
-mm <sup>2</sup>	0.14-2.5mm <sup>2</sup>
-AWG	26-14

## • Features

- Shielding bus separate from housing potential
- Perfect for transmission of sensitive signals
- The four pole Q-Coax contact is suitable for Ethernet Cat. 5e and PROFIBUS when diagonally wiring of the data pairs.

## Q-Coax Electromagnetic screening module

Assembly instructions see P10-63.



Combination with hinged frame and other modules possible.

### Crimp terminal



Insert	Designation	Order No.
Male	H2M-002-M	129 002 001 0001
Female	H2M-002-F	129 002 002 0001

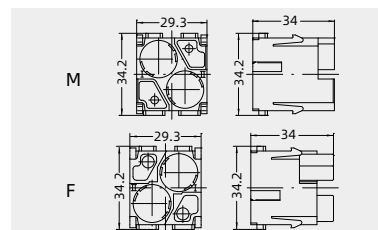

### Q-Coax metal adapter



Description	Designation	Order No.
	APT-H2MQ	198 002 007 0006

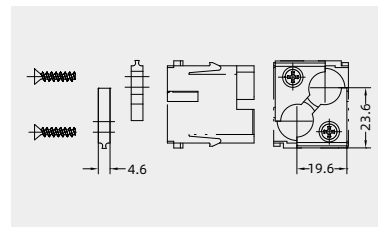

### Q-Coax plastic adapter



Description	Designation	Order No.
	APT.P-H2MQ	198 002 007 0032

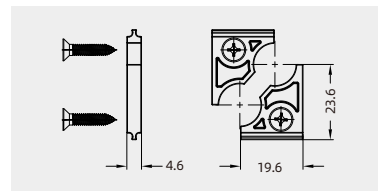

### Rubber stopper



Description	Designation	Order No.
	φ16*10	198 002 099 0035

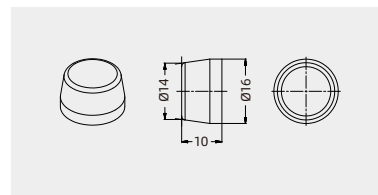

### Q-Coax 4 + shielding

Crimp contacts 10A  
Order crimp contacts separately  
Cable diameter 3mm-9.5mm



Description	Designation	Order No.
Male	EMC-004-MC	129 004 010 0082
Female	EMC-004-FC	129 004 020 0082

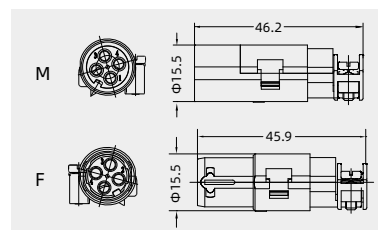

## Crimp contacts

### Crimp contacts 10A

Contact resistance ≤ 3mΩ  
gold plated



More 10A crimp contacts  
see P13-02, P13-03.

Wire gauge	Male	Order No.	Female	Order No.
0.09-0.25	CDGM-0.25	101 017 210 0101	CDGF-0.25	101 017 220 0101
0.14-0.37	CDGM-0.37	101 017 210 0301	CDGF-0.37	101 017 220 0301
0.5	CDGM-0.50	101 017 210 0401	CDGF-0.50	101 017 220 0401
0.75	CDGM-0.75	101 017 210 0601	CDGF-0.75	101 017 220 0601
1	CDGM-1.0	101 017 210 0801	CDGF-1.0	101 017 220 0801
1.5	CDGM-1.5	101 017 210 0901	CDGF-1.5	101 017 220 0901
2.5	CDGM-2.5	101 017 210 1001	CDGF-2.5	101 017 220 1001

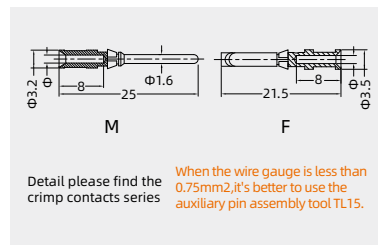

Notes: The tools for crimp terminal may influence the product quality and stability. Please select the tools recognized by our company.

\*Please find the details of crimp contact tools on page 32-02~32-05.

# Q-Coax Electromagnetic screening module

Assembly instructions see P10-63.



Combination with hinged frame and other modules possible.

## Crimp terminal



Insert	Designation	Order No.
Male	H2M-002-M	129 002 001 0001
Female	H2M-002-F	129 002 002 0001

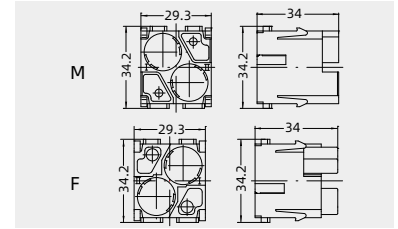

## Q-Coax metal adapter



Description	Designation	Order No.
	APT-H2MQ	198 002 007 0006

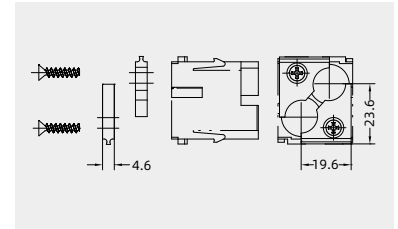

## Q-Coax plastic adapter



Description	Designation	Order No.
	APT.P-H2MQ	198 002 007 0032

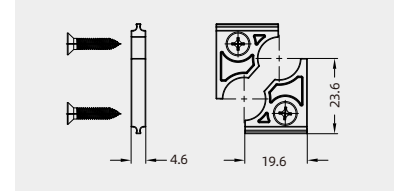

## Rubber stopper



Description	Designation	Order No.
	φ16*10	198 002 099 0035

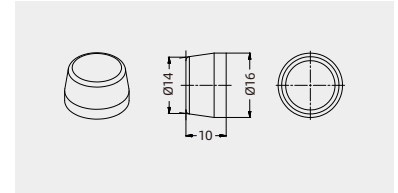

## Q-Coax 8 + shielding

Crimp contacts 5A  
Order crimp contacts separately  
Cable diameter 3mm-9.5mm



Description	Designation	Order No.
Male	EMC-008-MC	129 008 010 0082
Female	EMC-008-FC	129 008 020 0082

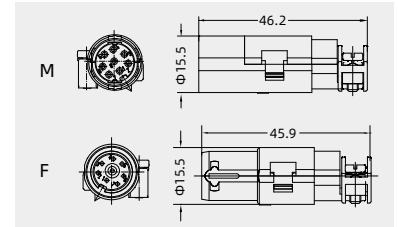

HM

## Crimp contacts

### Crimp contacts 5A

Contact resistance ≤ 3mΩ  
gold plated



Male	Order No.	Female	Order No.
CSGM-0.25	101 014 210 0101	CSGF-0.25	101 014 220 0101
CSGM-0.33	101 014 210 0201	CSGF-0.33	101 014 220 0201
CSGM-0.52	101 014 210 0501	CSGF-0.52	101 014 220 0501

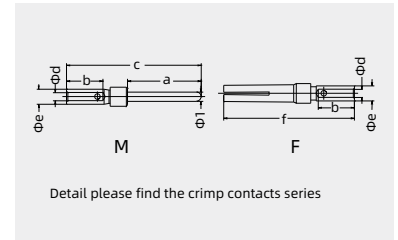

Notes: The tools for crimp terminal may influence the product quality and stability. Please select the tools recognized by our company.

\*Please find the details of crimp contact tools on page 32-02~32-05.

Stamped contacts 5A

Contact resistance  $\leq 10\text{m}\Omega$

silver plated



gold plated



coil stock



Note: 10kpcs/volume

	Male	Order No.	Female	Order No.
silver plated	CSSM-0.82P	101 014 110 0750	CSSF-0.82P	101 014 120 0750
gold plated				
	CSGM-0.82P	101 014 210 0750	CSGF-0.82P	101 014 220 0750

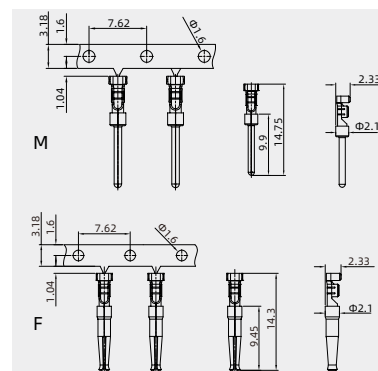

# Q-Coax Electromagnetic screening module

Assembly instructions see P10-63.

Hoods/Housings: size 3A with sealing, please find the details on page 10-64~10-70.

## Crimp terminal



Insert	Designation	Order No.
Male	H3A-001-M	121 001 001 0001
Female	H3A-001-F	121 001 002 0001

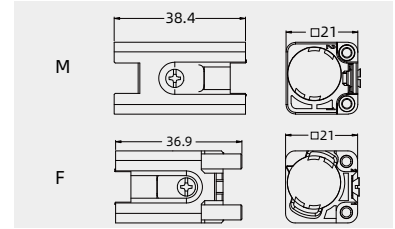

## Q-Coax 4 + shielding

Crimp contacts 10A  
Order crimp contacts separately  
Cable diameter 3mm-9.5mm



Description	Designation	Order No.
Male	EMC-004-MC	129 004 010 0082
Female	EMC-004-FC	129 004 020 0082

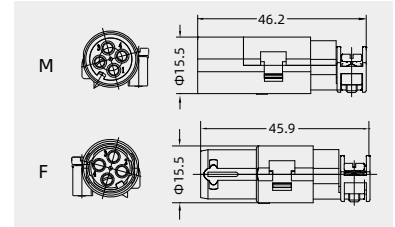

## Q-Coax 8 + shielding

Crimp contacts 5A  
Order crimp contacts separately  
Cable diameter 3mm-9.5mm



Description	Designation	Order No.
Male	EMC-008-MC	129 008 010 0082
Female	EMC-008-FC	129 008 020 0082

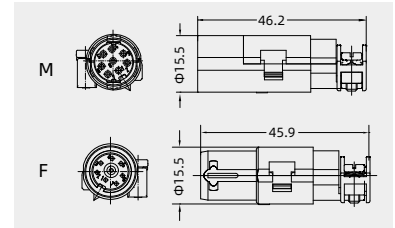

## Crimp contacts

### Crimp contacts 5A

Contact resistance  $\leq 3m\Omega$   
gold plated

Male	Order No.	Female	Order No.
CSGM-0.25	101 014 210 0101	CSGF-0.25	101 014 220 0101
CSGM-0.33	101 014 210 0201	CSGF-0.33	101 014 220 0201
CSGM-0.52	101 014 210 0501	CSGF-0.52	101 014 220 0501

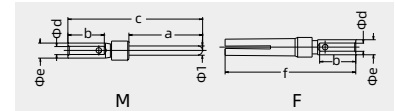

Detail please find the crimp contacts series

### Stamped contacts 5A

Contact resistance  $\leq 10m\Omega$

silver plated



gold plated



coil stock



Note: 10kpcs/volume

Male	Order No.	Female	Order No.
CSSM-0.82P	101 014 110 0750	CSSF-0.82P	101 014 120 0750
CSGM-0.82P	101 014 210 0750	CSGF-0.82P	101 014 220 0750

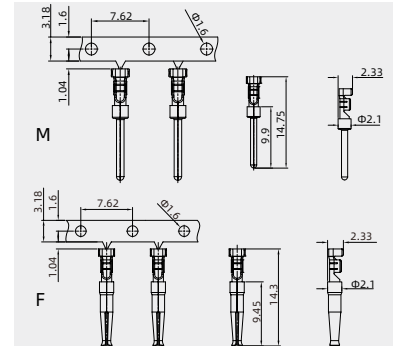

### Crimp contacts 10A

Contact resistance  $\leq 3m\Omega$   
gold plated



More 10A crimp contacts  
see P13-02, P13-03.

Wire gauge	Male	Order No.	Female	Order No.
0.09-0.25	CDGM-0.25	101 017 210 0101	CDGF-0.25	101 017 220 0101
0.14-0.37	CDGM-0.37	101 017 210 0301	CDGF-0.37	101 017 220 0301
0.5	CDGM-0.50	101 017 210 0401	CDGF-0.50	101 017 220 0401
0.75	CDGM-0.75	101 017 210 0601	CDGF-0.75	101 017 220 0601
1	CDGM-1.0	101 017 210 0801	CDGF-1.0	101 017 220 0801
1.5	CDGM-1.5	101 017 210 0901	CDGF-1.5	101 017 220 0901
2.5	CDGM-2.5	101 017 210 1001	CDGF-2.5	101 017 220 1001

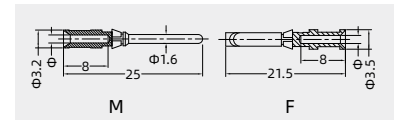

Detail please find the crimp contacts series  
When the wire gauge is less than 0.75mm2, it's better to use the auxiliary pin assembly tool TL15.

Notes: The tools for crimp terminal may influence the product quality and stability. Please select the tools recognized by our company.

\*Please find the details of crimp contact tools on page 32-02~32-05.



# Coax Electromagnetic screening module



## Technical characteristics

Specifications	DIN EN 60 664	DIN EN 61 984
Approvals	VDE CE ENEC	
Inserts		
Number of contacts	1,2	
Insulation resistance	$\geq 10^{10}\Omega$	
Material	polycarbonate	
Limiting temperatures	-40°C ...+85°C	
Flammability acc. to UL 94	V0	
Mechanical working life(mating cycles)	$\geq 500$	
Coax contacts		
Number of contacts	1 + shielding	
Electrical data acc. to EN 61 984		
- D Coax	10A 50V 0.8kV 3	
- E Coax	16A 50V 0.8kV 3	
Rated current	10/16A	
Rated voltage	50V	
Rated impulse voltage	0.8kV	
Pollution degree	3	
Impedance		
- D Coax	75Ω	
- E Coax	50Ω	
Material		
- Insulator	polycarbonate	
- Outer conductor	zinc alloy	
Contact resistance	$\leq 4m\Omega$	
Limiting temperatures	-40°C ...+85°C	
Flammability acc. to UL 94	V0	
Outer surface finish	nickel	
Cable diameter	3-9.5mm	
D Coax contacts(10A)		
Material	copper alloy	
Surface	hard-gold plated	
Contact resistance	$\leq 3m\Omega$	
Crimp terminal		
-mm <sup>2</sup>	0.14-2.5mm <sup>2</sup>	
-AWG	26-14	
E Coax contacts		
Material	copper alloy	
Surface	hard-gold plated	
Contact resistance	$\leq 1m\Omega$	
Crimp terminal		
-mm <sup>2</sup>	0.14-4mm <sup>2</sup>	
-AWG	26-12	

## Features

- Shielding bus separate from housing potential
- Perfect for transmission of sensitive signals
- The four pole Q-Coax contact is suitable for Ethernet Cat. 5e and PROFIBUS when diagonally wiring of the data pairs.

## Transmission characteristics

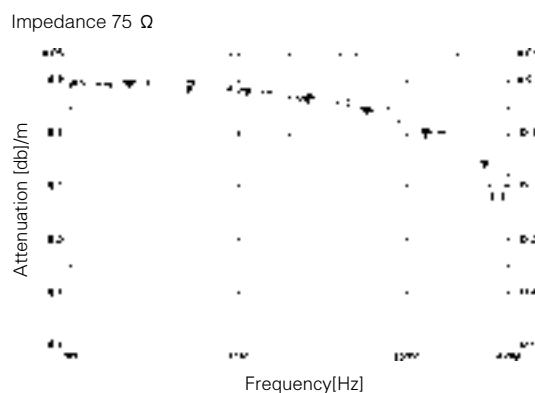

- 75 Ω cable
  - 75 Ω cable with D Coax contacts
- 75 Ω coax cable diameter shielding: 7.3 mm

## Impedance 50 Ω

E Coax with ETCS S21 Eurobalise cable (4 mm <sup>2</sup> )	27 MHz
Return loss [db]	35,4
Attenuation [db]	0,017

E Coax with RG 213 cable(2.5 mm <sup>2</sup> )	200 MHz	500 MHz	1,0 GHz	1,2 GHz	1,5 GHz	2,0 GHz	2,5 GHz
Return loss [db]	23,8	21,1	>18,7	>17,7	>16,4	>14,1	>12,0
Attenuation [db]	0,07	0,11	0,17	0,2	<0,23	<0,53	<2,0

# Coax Electromagnetic screening module

Assembly instructions see P10-63.



Combination with hinged frame and other modules possible.

## Crimp terminal



Insert	Designation	Order No.
Male	H2M-002-M	129 002 001 0001
Female	H2M-002-F	129 002 002 0001

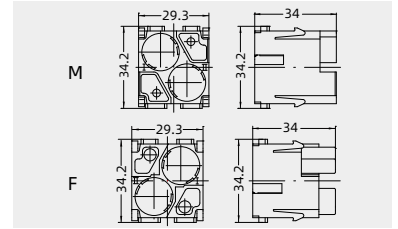

## Q-Coax metal adapter



Description	Designation	Order No.
	APT-H2MQ	198 002 007 0006

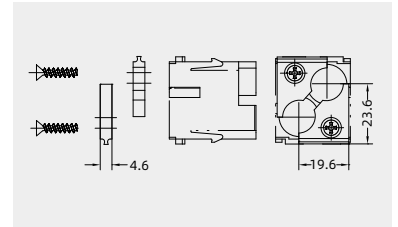

## Q-Coax plastic adapter



Description	Designation	Order No.
	APT.P-H2MQ	198 002 007 0032

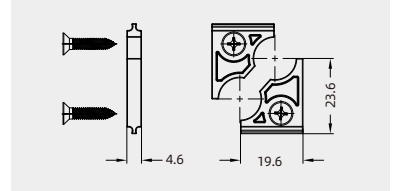

## Rubber stopper



Description	Designation	Order No.
	φ16*10	198 002 099 0035

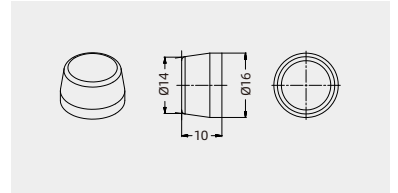

## D Coax 1 + shielding

Impedance 75Ω  
Crimp contacts 10A  
Order crimp contacts separately  
Cable diameter 3mm-9.5mm



Description	Designation	Order No.
Male	EMC-001-MC	129 001 010 0082
Female	EMC-001-FC	129 001 020 0082

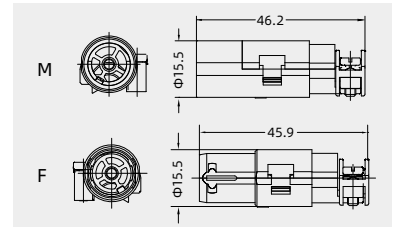

HM

## Crimp contacts

### Crimp contacts 10A

Contact resistance ≤ 3mΩ  
gold plated



More 10A crimp contacts  
see P13-02, P13-03.

Wire gauge	Male	Order No.	Female	Order No.
0.09-0.25	CDGM-0.25	101 017 210 0101	CDGF-0.25	101 017 220 0101
0.14-0.37	CDGM-0.37	101 017 210 0301	CDGF-0.37	101 017 220 0301
0.5	CDGM-0.50	101 017 210 0401	CDGF-0.50	101 017 220 0401
0.75	CDGM-0.75	101 017 210 0601	CDGF-0.75	101 017 220 0601
1	CDGM-1.0	101 017 210 0801	CDGF-1.0	101 017 220 0801
1.5	CDGM-1.5	101 017 210 0901	CDGF-1.5	101 017 220 0901
2.5	CDGM-2.5	101 017 210 1001	CDGF-2.5	101 017 220 1001

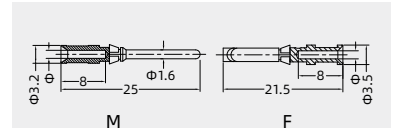

Detail please find the crimp contacts series  
When the wire gauge is less than 0.75mm2, it's better to use the auxiliary pin assembly tool TL15.

Notes: The tools for crimp terminal may influence the product quality and stability. Please select the tools recognized by our company.

\*Please find the details of crimp contact tools on page 32-02~32-05.

## Coax Electromagnetic screening module

Assembly instructions see P10-63.



Combination with hinged frame and other modules possible.

## Crimp terminal



Insert	Designation	Order No.
Male	H2M-002-M	129 002 001 0001
Female	H2M-002-F	129 002 002 0001

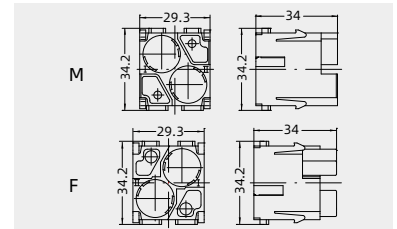

## Q-Coax metal adapter



Description	Designation	Order No.
	APT-H2MQ	198 002 007 0006

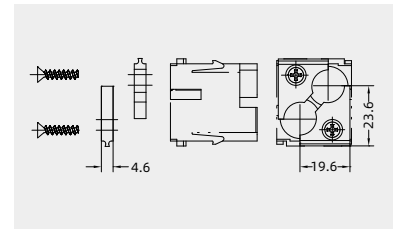

## Q-Coax plastic adapter



Description	Designation	Order No.
	APT.P-H2MQ	198 002 007 0032

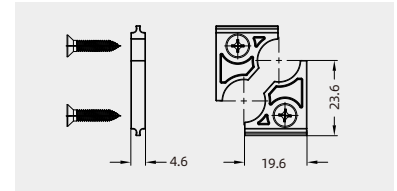

## Rubber stopper



Description	Designation	Order No.
	φ16*10	198 002 099 0035

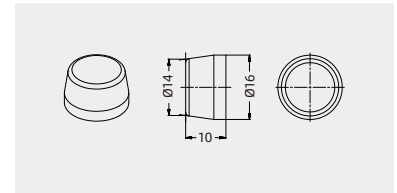

## E Coax 1 + shielding

Impedance 50Ω  
Crimp contacts 16A  
Order crimp contacts separately  
Cable diameter 3mm-9.5mm



Description	Designation	Order No.
Male	EMC-001-MC/E	129 001 010 0083
Female	EMC-001-FC/E	129 001 020 0083

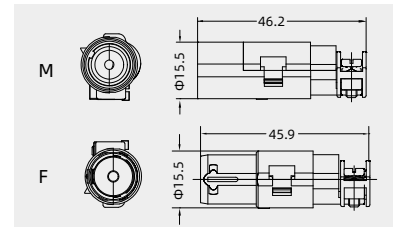

## Crimp contacts

## Crimp contacts 16A

Contact resistance ≤ 1mΩ  
gold plated



Wire gauge	Male	Order No.	Female	Order No.
0.14-0.37	CEGM-0.37	101 019 210 0301	CEGF-0.37	101 019 220 0301
0.5	CEGM-0.50	101 019 210 0401	CEGF-0.50	101 019 220 0401
0.75	CEGM-0.75	101 019 210 0601	CEGF-0.75	101 019 220 0601
1	CEGM-1.0	101 019 210 0801	CEGF-1.0	101 019 220 0801
1.5	CEGM-1.5	101 019 210 0901	CEGF-1.5	101 019 220 0901
2.5	CEGM-2.5	101 019 210 1001	CEGF-2.5	101 019 220 1001
3	CEGM-3.0	101 019 210 1101	CEGF-3.0	101 019 220 1101
4	CEGM-4.0	101 019 210 1201	CEGF-4.0	101 019 220 1201

More 16A crimp contacts see P13-04.

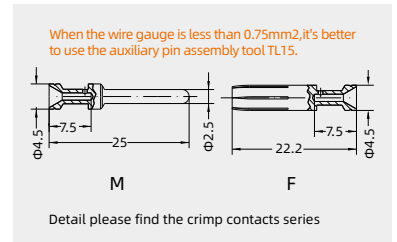

Notes: The tools for crimp terminal may influence the product quality and stability. Please select the tools recognized by our company.

\*Please find the details of crimp contact tools on page 32-02~32-05.

## Coax Electromagnetic screening module

Assembly instructions see P10-63.

Hoods/Housings: size 3A(top entry) with sealing, please find the details on page 10-64~10-70.

## Crimp terminal



Insert	Designation	Order No.
Male	H3A-001-M	121 001 001 0001
Female	H3A-001-F	121 001 002 0001

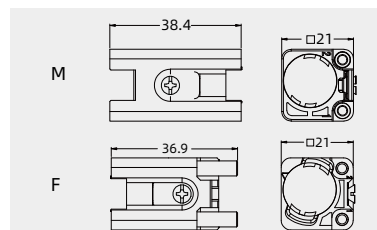

## D Coax 1 + shielding

Impedance 75Ω  
Crimp contacts 10A  
Order crimp contacts separately  
Cable diameter 3mm-9.5mm



Description	Designation	Order No.
Male	EMC-001-MC	129 001 010 0082
Female	EMC-001-FC	129 001 020 0082

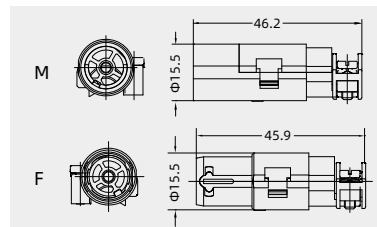

## E Coax 1 + shielding

Impedance 50Ω  
Crimp contacts 16A  
Order crimp contacts separately  
Cable diameter 3mm-9.5mm



Description	Designation	Order No.
Male	EMC-001-MC/E	129 001 010 0083
Female	EMC-001-FC/E	129 001 020 0083

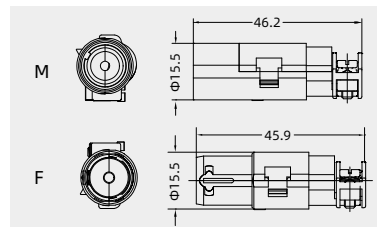

## Crimp contacts

## Crimp contacts 10A

Contact resistance ≤ 3mΩ  
gold plated



More 10A crimp contacts  
see P13-02, P13-03.

Wire gauge	Male	Order No.	Female	Order No.
0.09-0.25	CDGM-0.25	101 017 210 0101	CDGF-0.25	101 017 220 0101
0.14-0.37	CDGM-0.37	101 017 210 0301	CDGF-0.37	101 017 220 0301
0.5	CDGM-0.50	101 017 210 0401	CDGF-0.50	101 017 220 0401
0.75	CDGM-0.75	101 017 210 0601	CDGF-0.75	101 017 220 0601
1	CDGM-1.0	101 017 210 0801	CDGF-1.0	101 017 220 0801
1.5	CDGM-1.5	101 017 210 0901	CDGF-1.5	101 017 220 0901
2.5	CDGM-2.5	101 017 210 1001	CDGF-2.5	101 017 220 1001

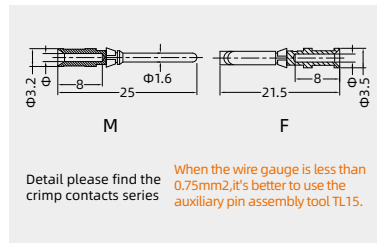

## Crimp contacts 16A

Contact resistance ≤ 1mΩ  
gold plated



More 16A crimp contacts see P13-04.

Wire gauge	Male	Order No.	Female	Order No.
0.14-0.37	CEGM-0.37	101 019 210 0301	CEGF-0.37	101 019 220 0301
0.5	CEGM-0.50	101 019 210 0401	CEGF-0.50	101 019 220 0401
0.75	CEGM-0.75	101 019 210 0601	CEGF-0.75	101 019 220 0601
1	CEGM-1.0	101 019 210 0801	CEGF-1.0	101 019 220 0801
1.5	CEGM-1.5	101 019 210 0901	CEGF-1.5	101 019 220 0901
2.5	CEGM-2.5	101 019 210 1001	CEGF-2.5	101 019 220 1001
3	CEGM-3.0	101 019 210 1101	CEGF-3.0	101 019 220 1101
4	CEGM-4.0	101 019 210 1201	CEGF-4.0	101 019 220 1201

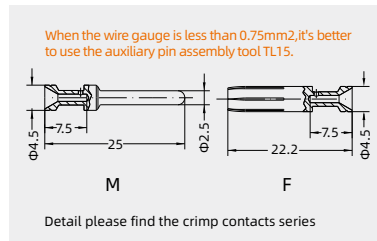

Notes: The tools for crimp terminal may influence the product quality and stability. Please select the tools recognized by our company.

\*Please find the details of crimp contact tools on page 32-02~32-05.

## Assembly instructions

### Q-Coax inserts

1. Strip cable acc. to drawing 1 and fold the shielding over the cable.
2. Crimp Dcontacts onto the wires.
3. Insert D contacts into corresponding cavities of insulator until they are snapped in.
4. Fit the insert including the cable into the opened shielded bushing. The coding pin of the shielded bushing has to meet the groove of the insulator.
5. Clamp the tilt over the shielding onto the cable by means of the special clamp (small opening for cable diameter of 3 - 6 mm, large opening for cable diameter of 6 - 9.5 mm).
6. Check the wiring.
7. Close the shielded bushing with the cover and insert it into the corresponding cavity of the Quintax Module as usual.

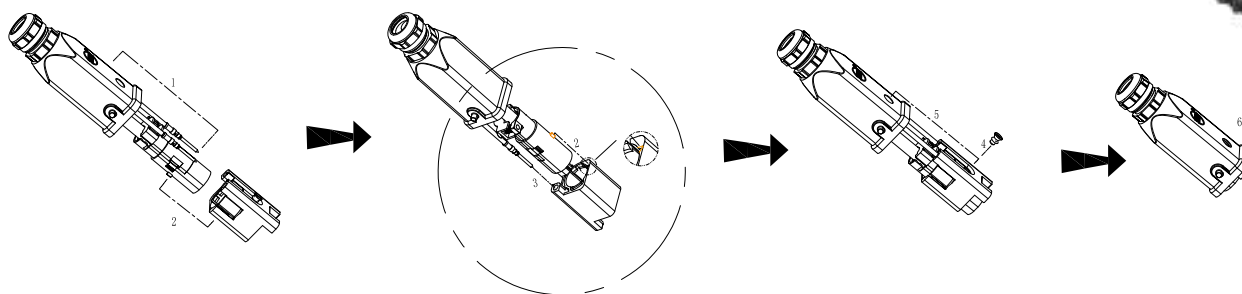
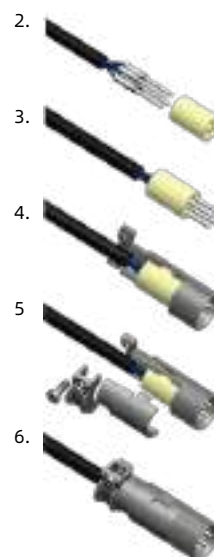
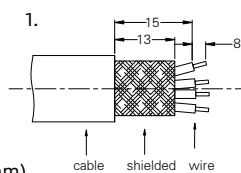

### Installation instruction of H3A-001-M/F

- Step 1: cable conductor will pass through H3A housing and Coax mortise (assembly type shown in the above figure) and 2pin D-type cold pressing pin will be installed. Refer to figure 1.
- Step 2: "triangulation positioning key" on the housing of Coax mortise is directed at "triangulation positioning slot" on the H3A-001-M/F plug for installation, which is shown in the figure 2. In addition, assembly is completed if "click" is heard. Namely, step surface of Coax has been stuck by the card hook.
- Step 3: 2 pin D-type pin will be installed in H3A-001-M/F mortise as per sequence of hole site.
- Step 4: grounding screw of H3A-001-M/F will be removed.
- Step 5: In addition, H3A-001-M/F mortise will be installed in H3A housing, aiming at grounding hole.
- Step 6: At last, grounding screw will be locked and installation is completed.

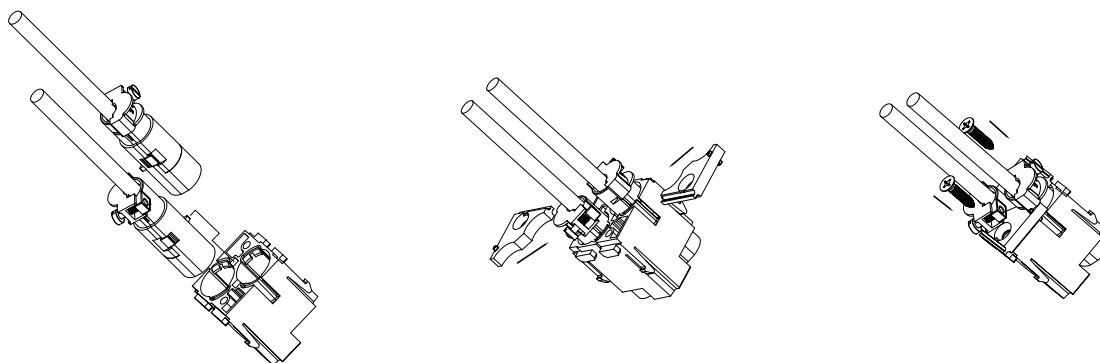

### Installation instruction of H2M-002-M/F

- Step 1: slug of Coax that has been installed will be installed in the plug of H2M-002-M/F. "triangulation positioning key" on the housing of Coax mortise must be directed at the "positioning slot" on the plug of H2M-002-M/F in the installation process. In addition, assembly is completed if "click" is heard. Namely, step surface of Coax has been stuck by the card hook.
- Step 2: a pair of APT-H2MQ adapter will be horizontally installed at the fixed step surface of H2M-002-M/F and Coax slug as per the arrow direction. Refer to the figure 2.
- Step 3: the adapter will be fixed with the screw lock, which means that H2M-002-M/F module has been installed.

# HMC-004 Coaxial module

50V 1.5A

## Inserts



Combination with hinged frame and other modules possible.

## Technical characteristics

Specifications	DIN EN 60 664 DIN EN 61 984
----------------	--------------------------------

Inserts	
Number of contacts	4
Electrical data acc. to EN 61 984	
-Rated current	1.5A
-Rated voltage	50V
-Contact resistance	≤ 10mΩ
-Impedance	50Ω, 75Ω
-Pollution degree	3
Insulation resistance	≥ 10 <sup>10</sup> Ω
Material	polycarbonate
Limiting temperatures	-40°C ...+125°C
Flammability acc. to UL 94	V0
Mechanical working life	≥ 500
- mating cycle	≥ 500



## Coaxial Module

Order Coaxial contacts separately



Insert	Designation	Order No.
Male	HMC-004-MC	129 004 010 0505
Female	HMC-004-FC	129 004 020 0505

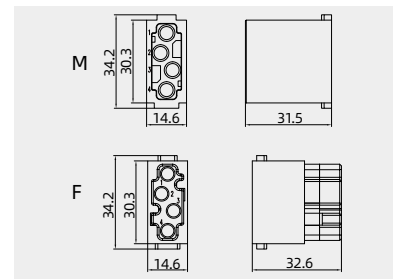
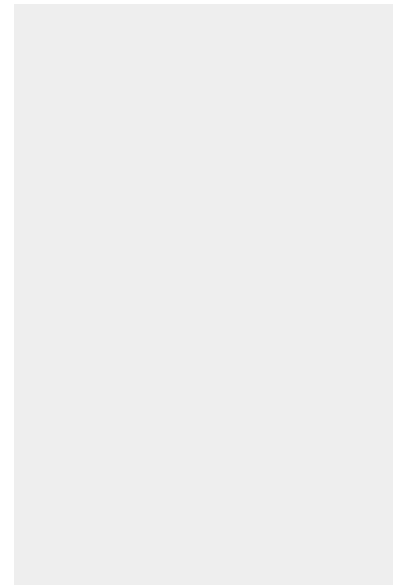

## Coaxial contacts

Contact resistance ≤ 10mΩ  
Impedance 50Ω  
Gold plated



Male	Order No.	Female	Order No.
SCGM50-5.5	101 110 210 0002	SCGF50-5.5	101 110 220 0002

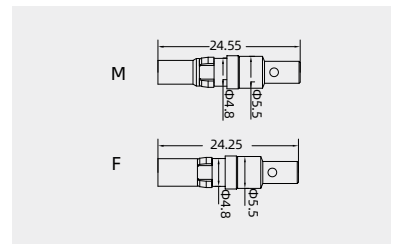

HM

## Tools



Crimping pliers



Wire gauge	Designation	Order No.
	TL31	198 001 001 0041

Contact removal tool



Application	Designation	Order No.
Coaxial Module	TL29	198 001 000 0041
H2MC-012		
HMC-004		

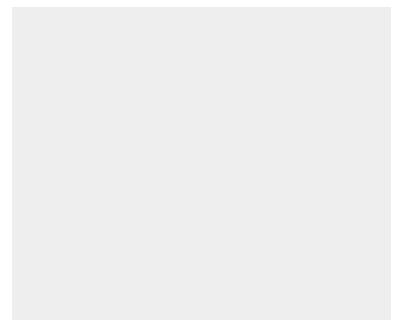

## H2MC-012 Coaxial module

50V 1.5A

### Inserts



Combination with hinged frame and other modules possible.

### Technical characteristics

Specifications	DIN EN 60 664 DIN EN 61 984
----------------	--------------------------------

Inserts	
Number of contacts	12
Electrical data acc. to EN 61 984	
-Rated current	1.5A
-Rated voltage	50V
-Contact resistance	≤ 10mΩ
-Impedance	50Ω,75Ω
-Pollution degree	3
Insulation resistance	≥ 10 <sup>10</sup> Ω
Material	polycarbonate
Limiting temperatures	-40°C ...+125°C
Flammability acc. to UL 94	V0
Mechanical working life	≥ 500
- mating cycle	≥ 500

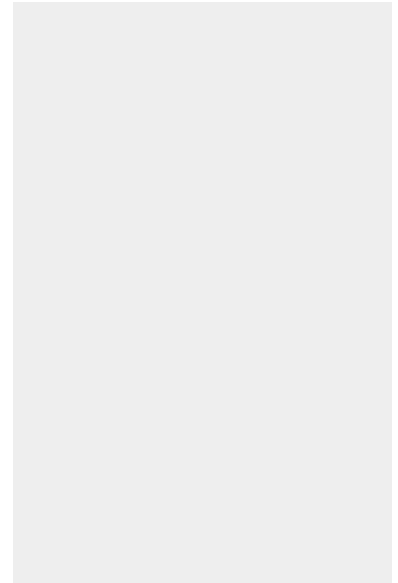

### Coaxial Module

Order Coaxial contacts separately



Insert	Designation	Order No.
Male	H2MC-012-MC	129 012 010 0503
Female	H2MC-012-FC	129 012 020 0503

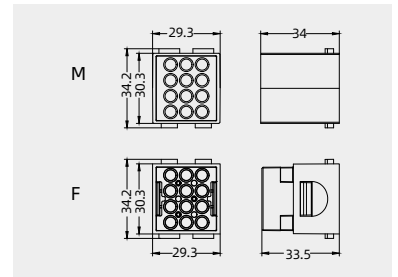

### Coaxial contacts

Contact resistance ≤ 10mΩ  
Impedance 50Ω  
Gold plated



Male	Order No.	Female	Order No.
SCGM50-5.5	101 110 210 0002	SCGF50-5.5	101 110 220 0002

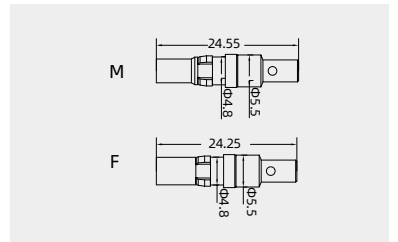

### Tools



Crimping pliers



Contact removal tool



Wire gauge	Designation	Order No.
	TL31	198 001 001 0041

Application	Designation	Order No.
Coaxial Module	TL29	198 001 000 0041
H2MC-012		
HMC-004		

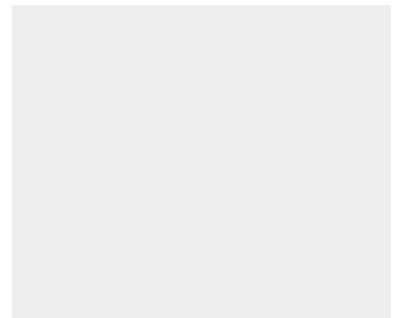

## 3A Plastic hoods/housings

With sealing

Degree of protection: IP65

## Hoods, top entry



Thread	Designation	Order No.
M20	H3A.P-TE/S-2B-M20	118 003 410 1102
PG11	H3A.P-TE/S-2B-PG11	118 003 410 1108

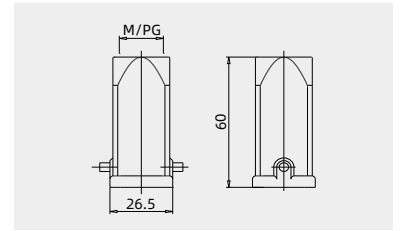

## Bulkhead mounted housings



Thread	Designation	Order No.
---	H3A.P-BK-1L	118 003 327 1001

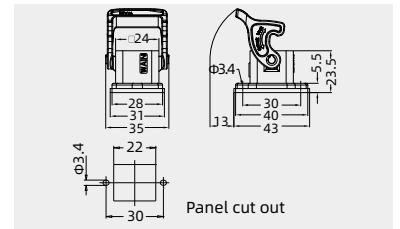

## Surface mounted housings



Thread	Designation	Order No.
M20	H3A.P-SF-1L-M20	118 003 227 1002
PG11	H3A.P-SF-1L-PG11	118 003 227 1008

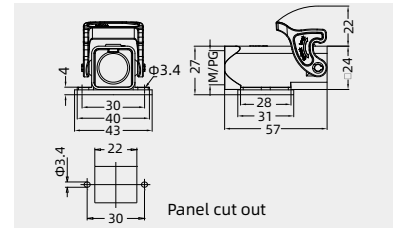

## Housings, cable to cable



Thread	Designation	Order No.
M20	H3A.P-CCT-1L-M20	118 003 727 1002
PG11	H3A.P-CCT-1L-PG11	118 003 727 1008

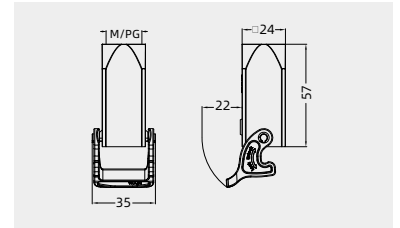





## 3A Plastic hoods/housings

With sealing

Degree of protection: IP65

### Protection covers



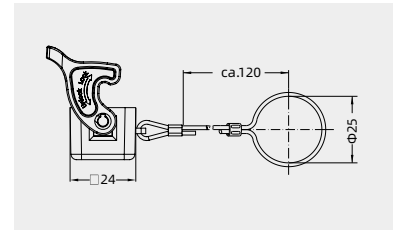

Connect way	Designation	Order No.
	H3A-CV-1L/1M (for male insert)	110 003 027 8001
	H3A-CV-1L/1F (for female insert)	110 003 027 8002



### Protection covers



Connect way	Designation	Order No.
	H3A-CV/S-2B/1	110 003 010 8003
	H3A-CV/S-2B/2	110 003 010 8006

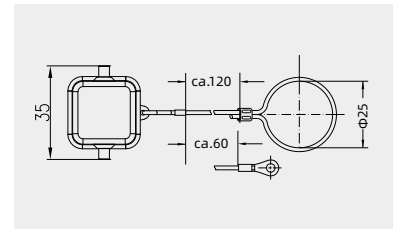

### 3A Metal hoods/housings

With sealing

Degree of protection: IP65

#### Hoods, top entry



Thread	Designation	Order No.
M20	H3A-TE/S-2B-M20	110 003 410 1102
PG11	H3A-TE/S-2B-PG11	110 003 410 1108

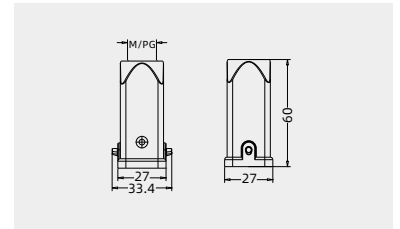

#### Bulkhead mounted housings



Thread	Designation	Order No.
---	H3A-BK-1L/W	110 003 324 1001

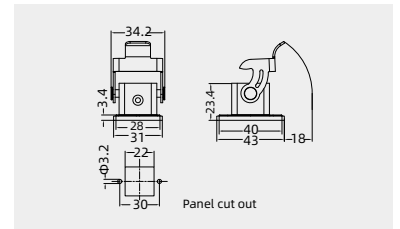

#### Bulkhead mounted housings



Thread	Designation	Order No.
---	H3A-BK-1L/W-MCV/S	110 003 364 1103

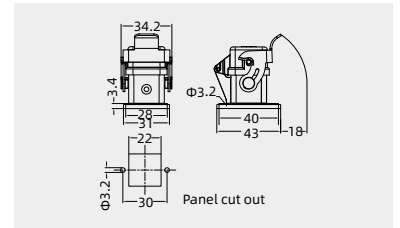

#### Surface mounted housings



Thread	Designation	Order No.
M20	H3A-SF-1L/W-M20	110 003 224 1002
PG11	H3A-SF-1L/W-PG11	110 003 224 1008

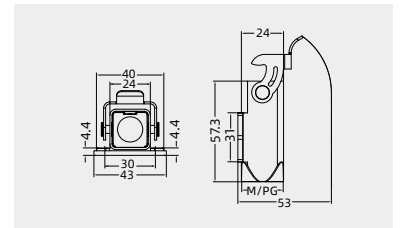

#### Housings, cable to cable



Thread	Designation	Order No.
M20	H3A-CCT-1L/W-M20	110 003 724 1002
PG11	H3A-CCT-1L/W-PG11	110 003 724 1008

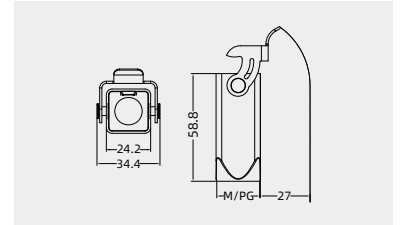

## 3A Metal hoods/housings(EMC)

With sealing

Degree of protection: IP65

Hoods, top entry



Thread	Designation	Order No.
M20	EMC.H3A-TE/S-2B-M20	110 603 410 1102
PG11	EMC.H3A-TE/S-2B-PG11	110 603 410 1108

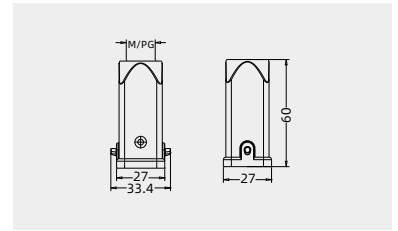

Bulkhead mounted housings



Thread	Designation	Order No.
---	EMCD.H3A-BK-1L/W	110 603 324 1101

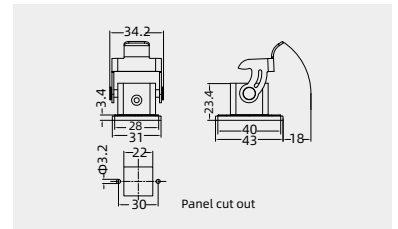

Bulkhead mounted housings



Thread	Designation	Order No.
---	EMCD.H3A-BK-1L/W-MCV/S	110 603 364 1103

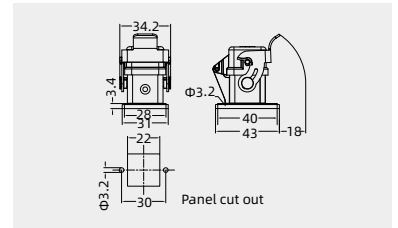

Surface mounted housings



Thread	Designation	Order No.
M20	EMC.H3A-SF-1L/W-M20	110 603 224 1002
PG11	EMC.H3A-SF-1L/W-PG11	110 603 224 1008

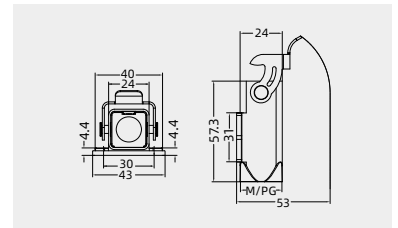

Housings, cable to cable



Thread	Designation	Order No.
M20	EMC.H3A-CCT-1L/W-M20	110 603 724 1002
PG11	EMC.H3A-CCT-1L/W-PG11	110 603 724 1008

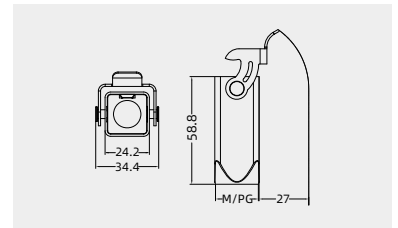



## 3A Metal hoods/housings

With sealing

Degree of protection: IP65

## Protection covers



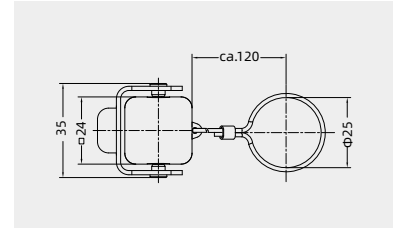

Connect way	Designation	Order No.
	H3A-MCV-1L/1M (for male insert)	110 003 024 8101
	H3A-MCV-1L/1F (for female insert)	110 003 024 8102



## Protection covers



Connect way	Designation	Order No.
	H3A-MCV/S-2B/1	110 003 010 8103
	H3A-MCV/S-2B/2	110 003 010 8106

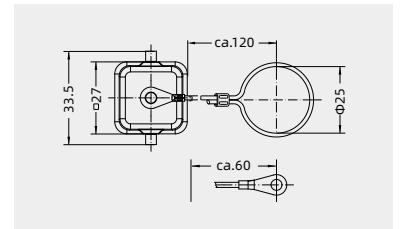

## 3A Pressure tight hoods/housings

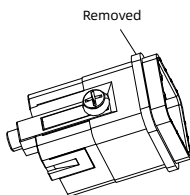

Note: Before installation, if there is a square seal ring on the used insert, the seal ring shall be removed before installation. For more details, please contact us.

Epoxy power paint  
Degree of protection: IP68

H version

## Hoods, top entry



Thread	Designation	Order No.
	Epoxy power paint · Screw locking	
M20	HP3A/H-TE-2S-M20	113 003 420 1002
PG13.5	HP3A/H-TE-2S-PG13.5	113 003 420 1009
	Epoxy power paint · Toggle locking	
M20	HP3A/H-TE-2T-M20	113 003 440 1002
PG13.5	HP3A/H-TE-2T-PG13.5	113 003 440 1009

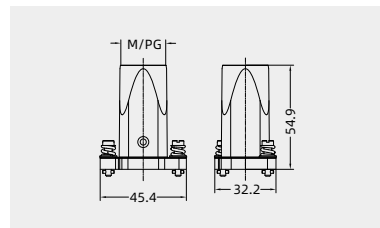

## Bulkhead mounted housings



Thread	Designation	Order No.
	Epoxy power paint · Screw locking	
---	HP3A/H-BK-2H	113 003 320 1001
	Epoxy power paint · Toggle locking	
---	HP3A/H-BK-2T	113 003 340 1001

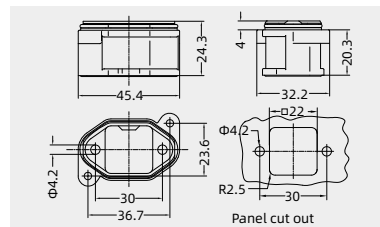

## Adaptor for Housings\*



Thread	Designation	Order No.
	Epoxy power paint	
---	HP3A/H-BK-SE	113 003 900 1001

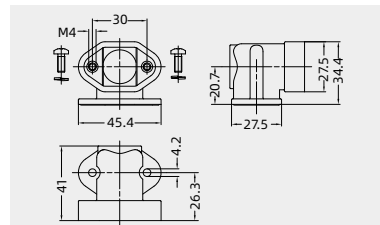

## Surface mounted housings



Thread	Designation	Order No.
	Epoxy power paint · Screw locking	
M20	HP3A/H-SF-2H-M20	113 003 220 1002
PG13.5	HP3A/H-SF-2H-PG13.5	113 003 220 1009

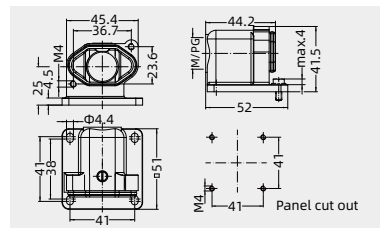

## Bulkhead mounted housings



Thread	Designation	Order No.
	Epoxy power paint · Screw locking	
---	HP3A/H-SF-2H	113 003 220 1001

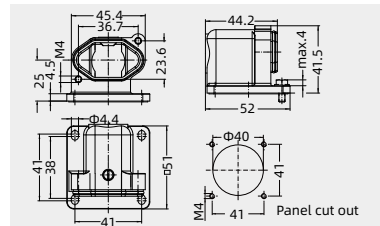

## 3A Pressure tight hoods/housings

## Epoxy power paint

Degree of protection: IP68

## Hoods, top entry, high construction



Thread	Designation	Order No.
	Epoxy power paint · Screw locking	
M25	HP3A/H-TEH-2S-M25	113 003 420 5003
	Epoxy power paint · Toggle locking	
M25	HP3A/H-TEH-2T-M25	113 003 440 5003

## H version

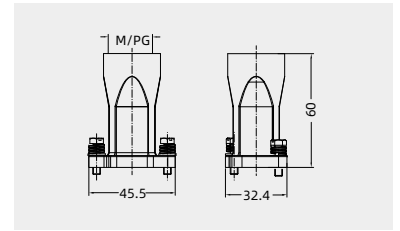

## Protection covers



Connect way	Designation	Order No.
	Epoxy power paint · Screw locking	
---	HP3A/H-MCV-2S	113 003 020 8103
	HP3A/H-MCV-2S/2S	113 003 020 8102
	Epoxy power paint · Toggle locking	
---	HP3A/H-MCV-2T	113 003 040 8103
	HP3A/H-MCV-2T/2S	113 003 040 8102

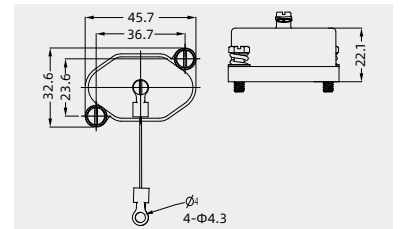

## Degree of protection: IP68

## Hoods, top entry



Thread	Designation	Order No.
M20	HP3A-TE-2S-M20	115 003 420 1002
PG11	HP3A-TE-2S-PG11	115 003 420 1008

## W version

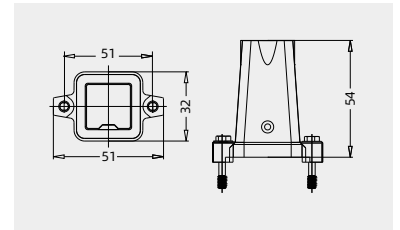

## Housings, bulkhead mounting



Connect way	Designation	Order No.
---	HP3A-BK-2H	115 003 320 1001

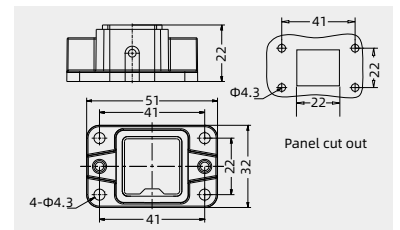

## HQ SERIES

Compact connector



## HQ-001 Compact inserts

### Technical characteristics

Specifications	DIN EN 60 664 DIN EN 61 984
Approvals	
Inserts	
Number of contacts	1
Electrical data acc. to EN 61 984	
-Rated current	100A
-Rated voltage	400V
-Rated impulse voltage	6kV
-Pollution degree	3
Rated voltage acc. to UL	-
Insulation resistance	$\geq 10^{10}\Omega$
Material polycarbonate	polycarbonate
Limiting temperatures	-40°C ...+125°C
Flammability acc. to UL 94	V0
Mechanical working life(mating cycles)	$\geq 500$
Contacts	
Material	copper alloy
Surface	hard-silver plated
Contact resistance	$\leq 0.3m\Omega$
Axial screw termination	
- mm <sup>2</sup>	10-25mm <sup>2</sup>
Cable outer diameter	$\leq 13.4m$
Strip length	10mm
Tightening torque	mm <sup>2</sup> : 10 16 25 N · m: 6 6 7
Hoods/Housings	
lastic hoods/housings	
-Material	polycarbonate
-Flammability acc. to UL 94	V0
-Degree of protection acc. to DIN EN 60 529 for coupled connector	IP65
Hoods/Housings, metal	
-Material	zinc die-cast
-Degree of protection acc. to DIN EN 60 529 for coupled connector	IP65/IP68

### Current carrying capacity

The current carrying is limited by maximum temperature of materials for inserts and contacts including terminals

Control and test procedures according to DIN EN 60512-5



# HQ-001 Compact inserts-high voltage

400V 100A 1+⊕



Hoods/Housings: size 3A, please find the details on page 15-06~15-16.1.

Hoods only suitable: H3A-TE (Conventional internal thread) ;H3A.P-TE(Conventional internal thread); HP3A/H-TEH

Housings only suitable: H3A-BK;H3A-SF;H3A-CCT;H3A.P-BK;H3A.P-SF;H3A.P-CCT;HP3A/H-BK;

## Inserts

Axial screw termination<sup>1)</sup>  
with heat shrink tube<sup>2)</sup>



Insert	Wire gauge	Designation	Order No.
	10-25mm <sup>2</sup>	HQ-001.1-M (10-25mm <sup>2</sup> )	130 001 011 0500
	10-25mm <sup>2</sup>	HQ-001.1-F (10-25mm <sup>2</sup> )	130 001 021 0500
	16-35mm <sup>2</sup>	HQ-001.2-M (16-35mm <sup>2</sup> )	130 001 011 0501
	16-35mm <sup>2</sup>	HQ-001.2-F (16-35mm <sup>2</sup> )	130 001 021 0501

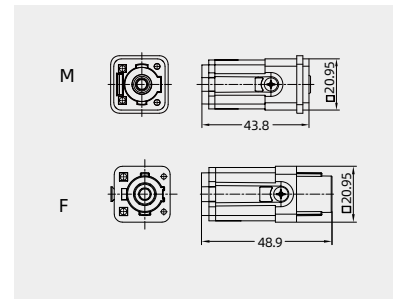

## Accessories

### Tool

Hex key



Description	Designation	Order No.
for axial setscrew with grip	SW-4*150	198 001 003 0007

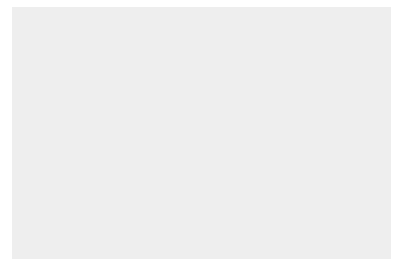

## HQ-002 Compact inserts



### Technical characteristics

Specifications	DIN EN 60 664 DIN EN 61 984
Approvals	<b>UL</b> ENEC
Inserts	
Number of contacts	2+PE
Electrical data acc. to EN 61 984	
-Rated current	40A
-Rated voltage	830V
-Rated impulse voltage	6kV
-Pollution degree	3
Rated voltage acc. to UL	600V
Insulation resistance	$\geq 10^{10}\Omega$
Material polycarbonate	polycarbonate
Limiting temperatures	-40°C ...+125°C
Flammability acc. to UL 94	V0
Mechanical working life(mating cycles)	$\geq 500$
Contacts	
Material	copper alloy
Surface	hard-silver plated
Contact resistance	$\leq 1m\Omega$
Axial screw termination	
- mm <sup>2</sup>	2.5-10mm <sup>2</sup>
- AWG	14-8
Tightening torque	1.8Nm
Stripping length	8mm <sup>±1</sup>
Hoods/Housings	
lastic hoods/housings	
-Material	polycarbonate
-Flammability acc. to UL 94	V0
-Degree of protection acc. to DIN EN 60 529 for coupled connector	IP65
Hoods/Housings, metal	
-Material	zinc die-cast
-Degree of protection acc. to DIN EN 60 529 for coupled connector	IP65/IP68

### Current carrying capacity

The current carrying is limited by maximum temperature of materials for inserts and contacts including terminals

Control and test procedures according to DIN EN 60512-5

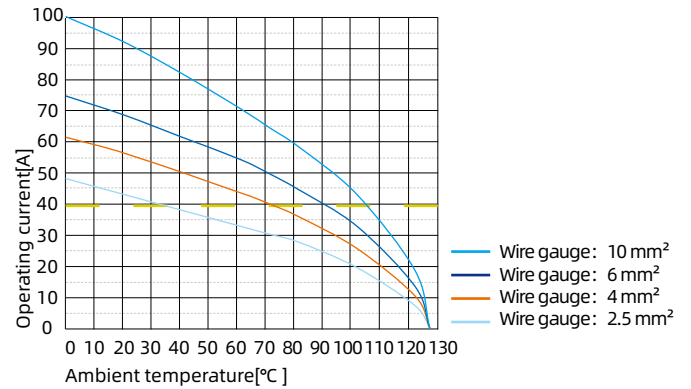

## HQ-002 Compact inserts-high voltage

830V 40A 2+ ⊕



### Inserts

Hoods/Housings: size 3A, please find the details on page 15-06~15-16.1.

Axial screw termination<sup>1)</sup>  
with heat shrink tube<sup>2)</sup>



Insert	Wire gauge	Designation	Order No.
Male	2.5-6.0mm <sup>2</sup>	HQ-002.1-M (2.5-6.0mm <sup>2</sup> )	130 002 011 0001
	4-10mm <sup>2</sup>	HQ-002.2-M (4-10mm <sup>2</sup> )	130 002 011 0002
Female	2.5-6.0mm <sup>2</sup>	HQ-002.1-F (2.5-6.0mm <sup>2</sup> )	130 002 021 0001
	4-10mm <sup>2</sup>	HQ-002.2-F (4-10mm <sup>2</sup> )	130 002 021 0002

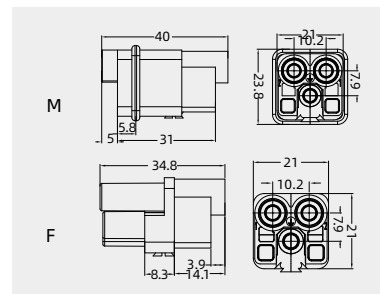

### Accessories

#### Tool

Hex key SW2



Description	Designation	Order No.
for axial setscrew with grip	SW-2*100	198 001 003 0002

#### Coding element



Description	Designation	Order No.
coding, pokayoke	CODE-Q2	198 002 005 0011

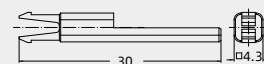

1) See P00-12-00-13 for the structural characteristics and description of Axial screw terminal.

2) Compared with HQV-002, HQ-002 has pressure-tight heat shrink tubing so that insulation performance has been increased and rated voltage has been enhanced.

## HQV-002 Compact inserts



### Technical characteristics

Specifications	DIN EN 60 664 DIN EN 61 984
Approvals	ENEC
Inserts	
Number of contacts	2+PE
Electrical data acc. to EN 61 984	
-Rated current	40A
-Rated voltage	400V
-Rated impulse voltage	6kV
-Pollution degree	3
Rated voltage acc. to UL	400V
Insulation resistance	$\geq 10^{10}\Omega$
Material	polycarbonate
Limiting temperatures	-40°C ...+125°C
Flammability acc. to UL 94	V0
Mechanical working life(mating cycles)	$\geq 500$
Contacts	
Material	copper alloy
Surface	hard-silver plated
Contact resistance	$\leq 1m\Omega$
Axial screw termination	
- mm <sup>2</sup>	2.5-10mm <sup>2</sup>
- AWG	14-8
Tightening torque	1.8Nm
Stripping length	8mm <sup>-1</sup>
Hoods/Housings	
Plastic hoods/housings	
-Material	polycarbonate
-Flammability acc. to UL 94	V0
-Degree of protection acc. to DIN EN 60 529 for coupled connector	IP65
Hoods/Housings, metal	
-Material	zinc die-cast
-Degree of protection acc. to DIN EN 60 529 for coupled connector	IP65/IP68

### Current carrying capacity

The current carrying is limited by maximum temperature of materials for inserts and contacts including terminals

Control and test procedures according to DIN EN 60512-5

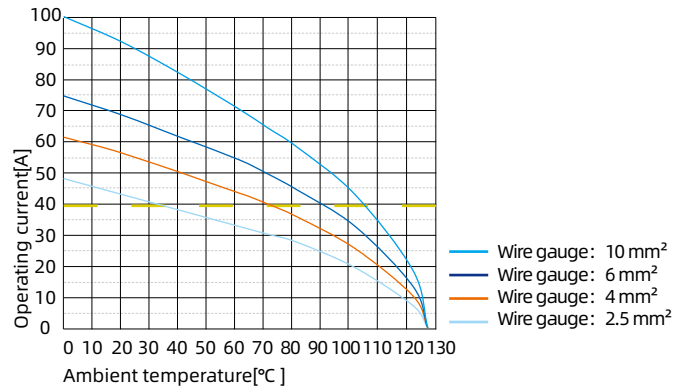

## HQV-002 Compact inserts

400V 40A 2+ 



### Inserts

Hoods/Housings: size 3A, please find the details on page 15-06~15-16.1.

Axial screw termination<sup>1)</sup>



Insert	Wire gauge	Designation	Order No.
Male	2.5-6.0mm <sup>2</sup>	HQV-002.1-M (2.5-6.0mm <sup>2</sup> )	130 002 011 0101
	4-10mm <sup>2</sup>	HQV-002.2-M (4-10mm <sup>2</sup> )	130 002 011 0102
Female	2.5-6.0mm <sup>2</sup>	HQV-002.1-F (2.5-6.0mm <sup>2</sup> )	130 002 021 0101
	4-10mm <sup>2</sup>	HQV-002.2-F (4-10mm <sup>2</sup> )	130 002 021 0102

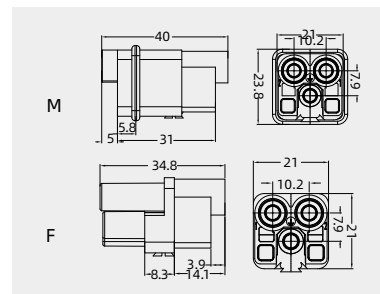

### Accessories

#### Tool

Hex key SW2



Description	Designation	Order No.
for axial setscrew with grip	SW-2*100	198 001 003 0002

#### Coding element



Description	Designation	Order No.
coding, pokayoke	CODE-Q2	198 002 005 0011

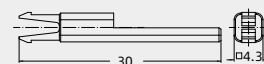

1) See P00-12-00-13 for the structural characteristics and description of Axial screw terminal.

## HQV-002 Compact inserts

400V 40A 2+ 



### Inserts

Hoods/Housings: size 3A, please find the details on page 15-06~15-16.1.

#### Crimp terminal



Insert	Designation	Order No.
Male	HQV-002/0-MC	130 002 010 0501
Female	HQV-002/0-FC	130 002 020 0501

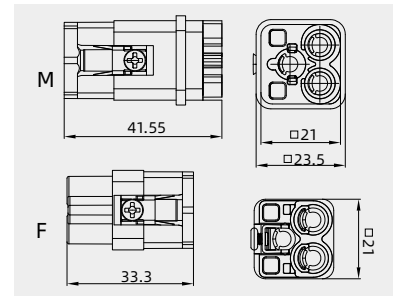

## Accessories

#### Tool

Hex key SW2



Description	Designation	Order No.
for axial setscrew with grip	SW-2*100	198 001 003 0002

#### Coding element



Description	Designation	Order No.
coding, pokayoke	CODE-Q2	198 002 005 0011

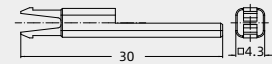

1) See P00-12~00-13 for the structural characteristics and description of Axial screw terminal.

## HQV-002 Compact inserts

400V 40A 2+ 



### Inserts

Hoods/Housings: size3A, please find the details on page 15-06~15-16.1.

#### Crimp terminal



Insert	Designation	Order No.
Male	HQ-002/0-MC	130 002 010 0500
Female	HQ-002/0-FC	130 002 020 0500

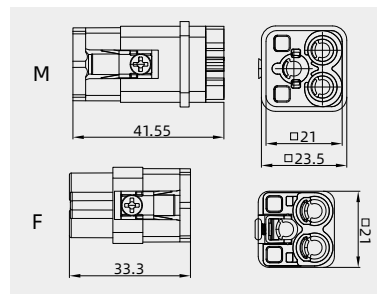

## Accessories

#### Tool

Hex key SW2



Description	Designation	Order No.
for axial setscrew with grip	SW-2*100	198 001 003 0002

#### Coding element



Description	Designation	Order No.
coding, pokayoke	CODE-Q2	198 002 005 0011

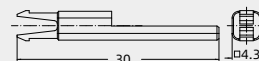

1) See P00-12~00-13 for the structural characteristics and description of Axial screw terminal.

# HQ-003/0 Compact inserts

## Technical characteristics

Specifications	DIN EN 60 664 DIN EN 61 984
Approvals	
Inserts	
Number of contacts	3+PE
Electrical data acc. to EN 61 984	
-Rated current	40A
-Rated voltage	400V
-Rated impulse voltage	6kV
-Pollution degree	3
Rated voltage acc. to UL/CSA	600V
Insulation resistance	$\geq 10^{10}\Omega$
Material	polycarbonate
Colour	RAL 7032 (light grey)
Limiting temperatures	-40°C ...+125°C
Flammability acc. to UL 94	V0
Mechanical working life(mating cycles)	$\geq 500$
Contacts	
Terminal:	crimp terminal
Material	copper alloy
Surface	hard-silver plated
	hard-gold plated
Contact resistance	$\leq 1m\Omega$
Wire gauge	
-mm <sup>2</sup>	1.5-10mm <sup>2</sup>
-AWG	16-8



# HQ-003/0 Compact inserts

400V 40A 3+ ⊕

## Inserts

Hoods/Housings: size3A, please find the details on page 15-06~15-16.1.

### Crimp terminal

order crimp contacts separately



Insert	Designation	Order No.
Male	HQ-003/0-MC	130 003 010 0002
Female	HQ-003/0-FC	130 003 020 0002

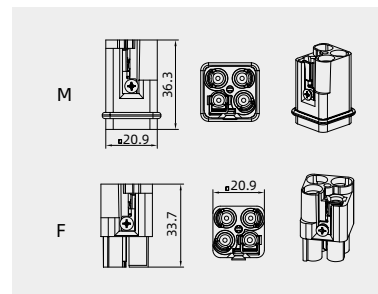

## Accessories

### Crimp contacts 40A

Contact resistance ≤ 1mΩ

silver plated



gold plated



Male	Order No.	Female	Order No.
CCSM-1.5	101 023 110 0901	CCSF-1.5	101 023 120 0901
CCSM-2.5	101 023 110 1001	CCSF-2.5	101 023 120 1001
CCSM-4.0	101 023 110 1201	CCSF-4.0	101 023 120 1201
CCSM-6.0	101 023 110 1301	CCSF-6.0	101 023 120 1301
CCSM-10.0	101 023 110 1401	CCSF-10.0	101 023 120 1401
CCGM-1.5	101 023 210 0901	CCGF-1.5	101 023 220 0901
CCGM-2.5	101 023 210 1001	CCGF-2.5	101 023 220 1001
CCGM-4.0	101 023 210 1201	CCGF-4.0	101 023 220 1201
CCGM-6.0	101 023 210 1301	CCGF-6.0	101 023 220 1301
CCGM-10.0	101 023 210 1401	CCGF-10.0	101 023 220 1401

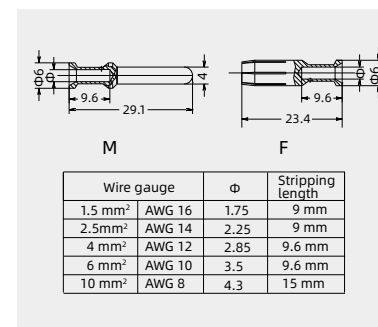

### Tools

Crimping tool



Contact removal tool



Wire gauge	Designation	Order No.
1.5-6mm <sup>2</sup>	TL02-0G	198 001 001 0012
4/6/10mm <sup>2</sup>	TL02-3G	198 001 001 0013

Application	Designation	Order No.
for crimp contacts 40A	TL06G	198 001 000 0009

### Coding element



Description	Designation	Order No.
coding, pokayoke	CODE-Q3	198 002 005 0034

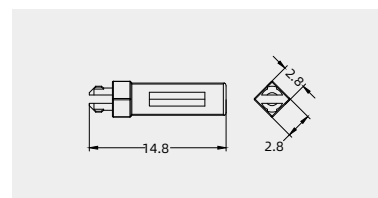

1) See P00-12-00-13 for the structural characteristics and description of Axial screw terminal.

## HQ-005/0 Compact inserts



### Technical characteristics

Specifications	DIN EN 60 664 DIN EN 61 984
Approvals	
Inserts	
Number of contacts	5+PE
Electrical data acc. to EN 61 984	
-Rated current	16A
-Rated voltage conductor - ground	230V
-Rated voltage conductor - conductor	400V
-Rated impulse voltage	4kV
-Pollution degree	3
-Pollution degree 2 also	16A 320/500V 4kV 2
Rated voltage acc. to UL	600V
Insulation resistance	$\geq 10^{10}\Omega$
Material	polycarbonate
Limiting temperatures	-40°C ...+125°C
Flammability acc. to UL 94	V0
Mechanical working life(mating cycles)	$\geq 500$
Contacts	
Material	copper alloy
Surface	hard-silver plated hard-gold plated
Contact resistance	$\leq 1m\Omega$
Crimp terminal	
- mm <sup>2</sup>	0.14-4.0mm <sup>2</sup>
- AWG	26-12
PE screw terminal	
-mm <sup>2</sup>	2.5mm <sup>2</sup>
-AWG	14
Hoods/Housings	
Plastic hoods/housings	
-Material	polycarbonate
-Flammability acc. to UL 94	V0
-Degree of protection acc. to DIN EN 60 529 for coupled connector	IP65
Hoods/Housings, metal	
-Material	zinc die-cast
-Degree of protection acc. to DIN EN 60 529 for coupled connector	IP65/IP68

### Current carrying capacity

The current carrying is limited by maximum temperature of materials for inserts and contacts including terminals

Control and test procedures according to DIN EN 60512-5

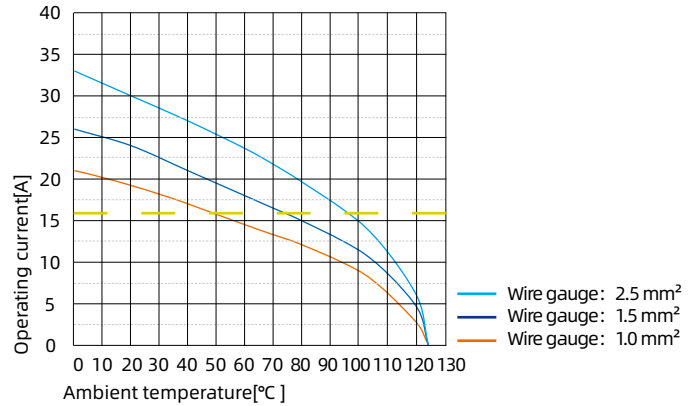

# HQ-005/0 Compact inserts

230/400V 16A 5+ ⊕



## Inserts

Hoods/Housings: size 3A, please find the details on page 15-06~15-16.1.

### Crimp terminal

order crimp contacts separately



Insert	Designation	Order No.
Male	HQ-005/0-MC	130 005 010 0001
Female	HQ-005/0-FC	130 005 020 0001

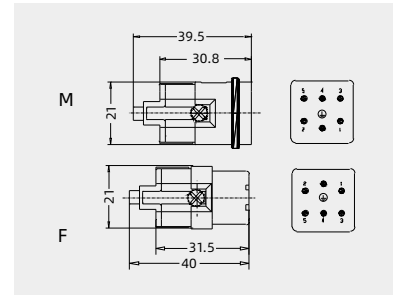

## Crimp contacts

### Crimp contacts 16A Contact

resistance ≤ 1mΩ

silver plated



gold plated



Male	Order No.	Female	Order No.
CESM-0.37	101 019 110 0301	CESF-0.37	101 019 120 0301
CESM-0.50	101 019 110 0401	CESF-0.50	101 019 120 0401
CESM-0.75	101 019 110 0601	CESF-0.75	101 019 120 0601
CESM-1.0	101 019 110 0801	CESF-1.0	101 019 120 0801
CESM-1.5	101 019 110 0901	CESF-1.5	101 019 120 0901
CESM-2.5	101 019 110 1001	CESF-2.5	101 019 120 1001
CESM-3.0	101 019 110 1101	CESF-3.0	101 019 120 1101
CESM-4.0	101 019 110 1201	CESF-4.0	101 019 120 1201
CEGM-0.37	101 019 210 0301	CEGF-0.37	101 019 220 0301
CEGM-0.50	101 019 210 0401	CEGF-0.50	101 019 220 0401
CEGM-0.75	101 019 210 0601	CEGF-0.75	101 019 220 0601
CEGM-1.0	101 019 210 0801	CEGF-1.0	101 019 220 0801
CEGM-1.5	101 019 210 0901	CEGF-1.5	101 019 220 0901
CEGM-2.5	101 019 210 1001	CEGF-2.5	101 019 220 1001
CEGM-3.0	101 019 210 1101	CEGF-3.0	101 019 220 1101
CEGM-4.0	101 019 210 1201	CEGF-4.0	101 019 220 1201

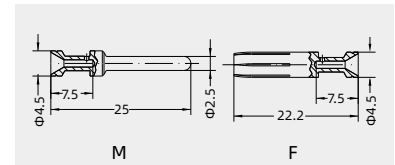

Identification	Wire gauge	Stripping length
no groove	0.14-0.37 mm <sup>2</sup> AWG 26-22	7.5mm
no groove	0.5 mm <sup>2</sup> AWG 20	7.5mm
1 groove	0.75 mm <sup>2</sup> AWG 18	7.5mm
1 groove	1 mm <sup>2</sup> AWG 18	7.5mm
2 groove	1.5 mm <sup>2</sup> AWG 16	7.5mm
3 groove	2.5 mm <sup>2</sup> AWG 14	7.5mm
wide groove	3 mm <sup>2</sup> AWG 12	7.5mm
no groove	4 mm <sup>2</sup> AWG 12	7.5mm

When the wire gauge is less than 0.75mm<sup>2</sup>, it's better to use the auxiliary pin assembly tool TL15.

### Relay contacts

silver plated



Wire gauge (mm <sup>2</sup> )	Designation	Order No.
1	CESM-1.0R	101 019 110 0808
1.5	CESM-1.5R	101 019 110 0908
2.5	CESM-2.5R	101 019 110 1008

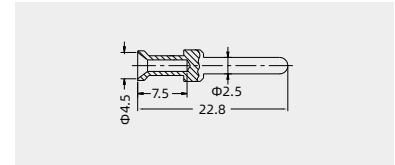

### Tools

#### Crimping tool



#### Contact removal tool



Wire gauge	Designation	Order No.
0.14-4mm <sup>2</sup>	TL02G	198 001 001 0011
Wire gauge: 0.14-0.37mm <sup>2</sup> please select TL02 Crimping tool.		
Application		
for crimp contacts 16A	TL01	198 001 000 0002

More tools detail please find the page 32-02~32-05.

### Coding element



Description	Designation	Order No.
coding, pokayoke	CODE-E	198 002 005 0002

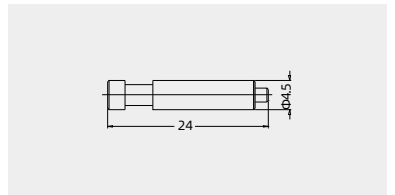
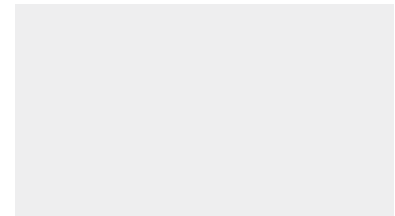

Notes: The tools for crimp terminal may influence the product quality and stability. Please select the tools recognized by our company.

# HQ-005/0 Compact inserts

230/400V 16A 5+



## Inserts

Hoods/Housings: size 3A, please find the details on page 15-06~15-16.1.

### Crimp terminal

order crimp contacts separately



Insert	Designation	Order No.
Male	HQ-005/0-MC/C	130 005 010 0505
Female	HQ-005/0-FC/C	130 005 020 0504

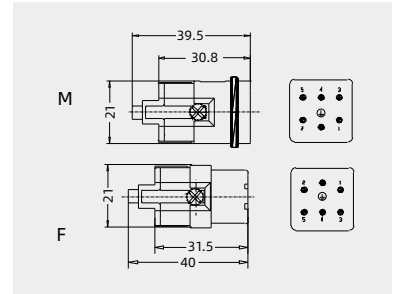

## Crimp contacts

### Crimp contacts 16A Contact

resistance ≤ 1mΩ

silver plated



gold plated



Male	Order No.	Female	Order No.
CESM-0.37	101 019 110 0301	CESF-0.37	101 019 120 0301
CESM-0.50	101 019 110 0401	CESF-0.50	101 019 120 0401
CESM-0.75	101 019 110 0601	CESF-0.75	101 019 120 0601
CESM-1.0	101 019 110 0801	CESF-1.0	101 019 120 0801
CESM-1.5	101 019 110 0901	CESF-1.5	101 019 120 0901
CESM-2.5	101 019 110 1001	CESF-2.5	101 019 120 1001
CESM-3.0	101 019 110 1101	CESF-3.0	101 019 120 1101
CESM-4.0	101 019 110 1201	CESF-4.0	101 019 120 1201
CEGM-0.37	101 019 210 0301	CEGF-0.37	101 019 220 0301
CEGM-0.50	101 019 210 0401	CEGF-0.50	101 019 220 0401
CEGM-0.75	101 019 210 0601	CEGF-0.75	101 019 220 0601
CEGM-1.0	101 019 210 0801	CEGF-1.0	101 019 220 0801
CEGM-1.5	101 019 210 0901	CEGF-1.5	101 019 220 0901
CEGM-2.5	101 019 210 1001	CEGF-2.5	101 019 220 1001
CEGM-3.0	101 019 210 1101	CEGF-3.0	101 019 220 1101
CEGM-4.0	101 019 210 1201	CEGF-4.0	101 019 220 1201

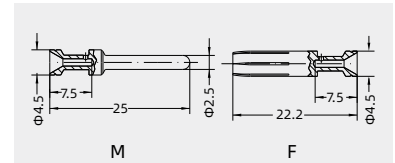

Identification	Wire gauge	Stripping length
no groove	0.14-0.37 mm <sup>2</sup> AWG 26-22	7.5mm
no groove	0.5 mm <sup>2</sup> AWG 20	7.5mm
1 groove	0.75 mm <sup>2</sup> AWG 18	7.5mm
1 groove	1 mm <sup>2</sup> AWG 18	7.5mm
2 groove	1.5 mm <sup>2</sup> AWG 16	7.5mm
3 groove	2.5 mm <sup>2</sup> AWG 14	7.5mm
wide groove	3 mm <sup>2</sup> AWG 12	7.5mm
no groove	4 mm <sup>2</sup> AWG 12	7.5mm

When the wire gauge is less than 0.75mm<sup>2</sup>, it's better to use the auxiliary pin assembly tool TL15.

### Relay contacts

silver plated



Wire gauge (mm <sup>2</sup> )	Designation	Order No.
1	CESM-1.0R	101 019 110 0808
1.5	CESM-1.5R	101 019 110 0908
2.5	CESM-2.5R	101 019 110 1008

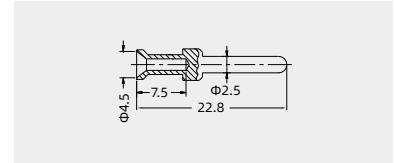

### Tools

#### Crimping tool



Wire gauge	Designation	Order No.
0.14-4mm <sup>2</sup>	TL02G	198 001 001 0011

Wire gauge: 0.14-0.37mm<sup>2</sup> please select TL02 Crimping tool.

#### Contact removal tool



Application	Designation	Order No.
for crimp contacts 16A	TL01	198 001 000 0002

More tools detail please find the page 32-02~32-05.

#### Coding element



Description	Designation	Order No.
coding, pokayoke	CODE-Q5/C	198 002 005 0042

Notes: The tools for crimp terminal may influence the product quality and stability. Please select the tools recognized by our company.

## HQ-005/0 Quick-in



### Technical characteristics

Specifications	DIN EN 60 664 DIN EN 61 984
Approvals	
Inserts	
Number of contacts	5+PE
Electrical data acc. to EN 61 984	
-Rated current	16A
-Rated voltage	230V/400V
-Rated impulse voltage	4kV
-Pollution degree	3
Insulation resistance	$\geq 10^{10}\Omega$
Material	polycarbonate
Colour	RAL 7032 (light grey)
Limiting temperatures	-40°C ...+125°C
Flammability acc. to UL 94	V0
Mechanical working life(mating cycles)	$\geq 500$
Contacts	
Terminal:	Spring terminal(Quick-in)
Material	copper alloy
Surface	hard-silver plated
Contact resistance	$\leq 3m\Omega$
Wire gauge	0.5-4.0mm <sup>2</sup> / 20-12AWG
Wire gauge(For wires with crimped ferrule)	0.14-2.5mm <sup>2</sup> / 26-14AWG
Stripping length	10±0.5mm

HQ-005/0 Quick-in

230/400V 16A 5+ 

Inserts

Hoods/Housings: size 3A, please find the details on page 15-06~15-16.1.

Spring terminal(Quick-in)



Insert	Designation	Order No.
Male	HQ-005/0-MQ	130 005 001 0001
Female	HQ-005/0-FQ	130 005 002 0001

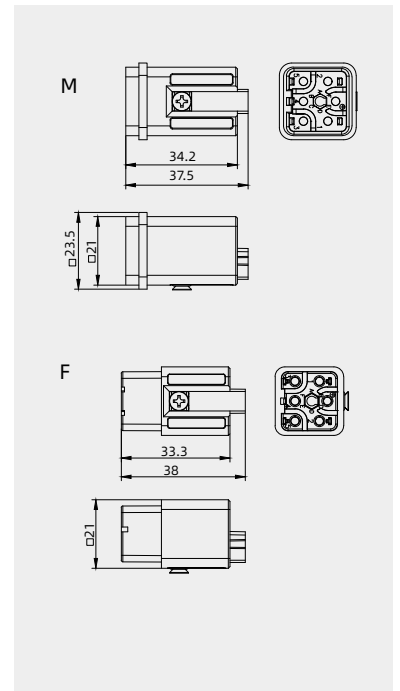

Coding element

Coding element



Description	Designation	Order No.
coding, pokayoke	CODE-Q5	198 002 005 0036

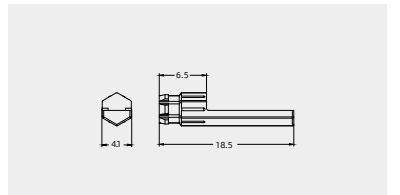

## HQ-007 Compact inserts



### Technical characteristics

Specifications	DIN EN 60 664 DIN EN 61 984
Approvals	
Inserts	
Number of contacts	7+PE
Electrical data acc. to EN 61 984	
-Rated current	10A
-Rated voltage	400V
-Rated impulse voltage	6kV
-Pollution degree	3
-Pollution degree 2 also	10A 400/690V 6kV 2
Rated voltage acc. to UL	600V
Insulation resistance	$\geq 10^{10}\Omega$
Material	polycarbonate
Limiting temperatures	-40°C ... +125°C
Flammability acc. to UL 94	V0
Mechanical working life(mating cycles)	$\geq 500$
Contacts	
Material	copper alloy
Surface	hard-silver plated
	hard-gold plated
Contact resistance	$\leq 3m\Omega$
Crimp terminal	
- mm <sup>2</sup>	0.14-2.5mm <sup>2</sup>
- AWG 26 ... 14	26-14
PE screw terminal	
-mm <sup>2</sup>	2.5mm <sup>2</sup>
-AWG	14
Hoods/Housings	
Plastic hoods/housings	
-Material	polycarbonate
-Flammability acc. to UL 94	V0
-Degree of protection acc. to DIN EN 60 529 for coupled connector	IP65
Hoods/Housings, metal	
-Material	zinc die-cast
-Degree of protection acc. to DIN EN 60 529 for coupled connector	IP65/IP68

### Current carrying capacity

The current carrying is limited by maximum temperature of materials for inserts and contacts including terminals

Control and test procedures according to DIN EN 60512-5

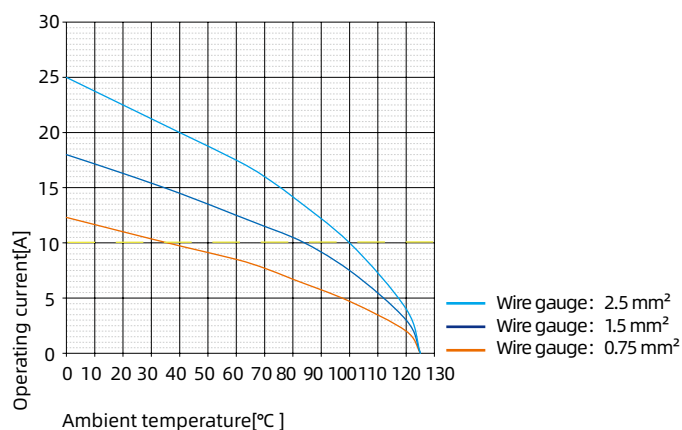

## HQ-007 Compact inserts

400V 10A 7+ ⊕



### Inserts

Hoods/Housings: size 3A, please find the details on page 15-06~15-16.1.

Crimp terminal  
order crimp contacts separately



Insert	Designation	Order No.
Male	HQ-007/0-MC <sup>1)</sup>	130 007 010 0001
Female	HQ-007/0-FC <sup>1)</sup>	130 007 020 0001

1).can match PCB adapter,see page 14-08~14-09.

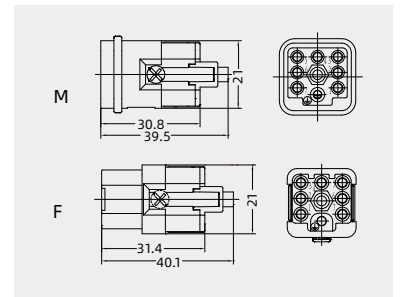

### Accessories

Crimp contacts 10A

Contact resistance ≤ 3mΩ

silver plated



gold plated

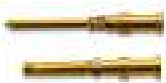

More crimp contacts 10A  
see P13-02,P13-03.

Tools



Wire gauge	Designation	Order No.
0.14-4mm <sup>2</sup>	TL02G	198 001 001 0011

Application	Designation	Order No.
for crimp contacts 10A	TL00	198 001 000 0001

More tools detail please find the page32-02~32-05.

Coding element



Description	Category	Designation	Order No.
coding,pokayoke	Male	CODE-Q7M	198 002 005 0007
	Female	CODE-Q7F	198 002 005 0008

Wire gauge	Φ	Stripping length
0.09-0.25 mm <sup>2</sup> AWG 28-24	0.65	5 mm
0.14-0.37 mm <sup>2</sup> AWG 26-22	0.9	8 mm
0.5 mm <sup>2</sup> AWG 20	1.1	8 mm
0.75 mm <sup>2</sup> AWG 18	1.3	8 mm
1 mm <sup>2</sup> AWG 18	1.45	8 mm
1.5 mm <sup>2</sup> AWG 16	1.75	8 mm
2.5 mm <sup>2</sup> AWG 14	2.25	6 mm

When the wire gauge is less than 0.75mm<sup>2</sup>,it's better to use the auxiliary pin assembly tool TL15.

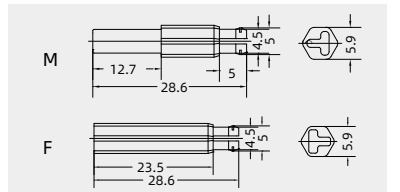
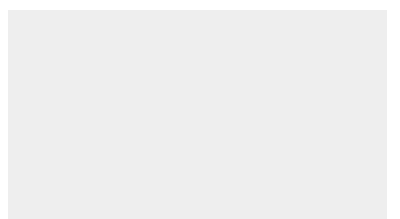

Notes: The tools for crimp terminal may influence the product quality and stability. Please select the tools recognized by our company.



## HQ-012/0 Compact inserts



### Technical characteristics

Specifications	DIN EN 60 664 DIN EN 61 984
Approvals	<b>UL</b> <b>CE</b> <b>EH</b>
Inserts	
Number of contacts	12+PE
Electrical data acc. to EN 61 984	
-Rated current	10A
-Rated voltage	400V
-Rated impulse voltage	6kV
-Pollution degree	3
-Pollution degree 2 also	10A 400/690V 6kV 2
Rated voltage acc. to UL	600V
Insulation resistance	$\geq 10^{10}\Omega$
Material	polycarbonate
Limiting temperatures	-40°C ...+125°C
Flammability acc. to UL 94	V0
Mechanical working life(mating cycles)	$\geq 500$
Contacts	
Material	copper alloy
Surface	hard-silver plated
	hard-gold plated
Contact resistance	$\leq 3m\Omega$
Crimp terminal	
-mm <sup>2</sup>	0.14-2.5mm <sup>2</sup>
-AWG	26-14
PE contact	
-mm <sup>2</sup>	0.5-2.5mm <sup>2</sup>
-AWG	20-14
Strip length	6-7mm
Hoods/Housings	
Plastic hoods/housings	
-Material	polycarbonate
-Flammability acc. to UL 94	V0
-Degree of protection acc. to DIN EN 60 529 for coupled connector	IP65
Hoods/Housings, metal	
-Material	zinc die-cast
-Degree of protection acc. to DIN EN 60 529 for coupled connector	IP65/IP68

### Current carrying capacity

The current carrying is limited by maximum temperature of materials for inserts and contacts including terminals

Control and test procedures according to DIN EN 60512-5

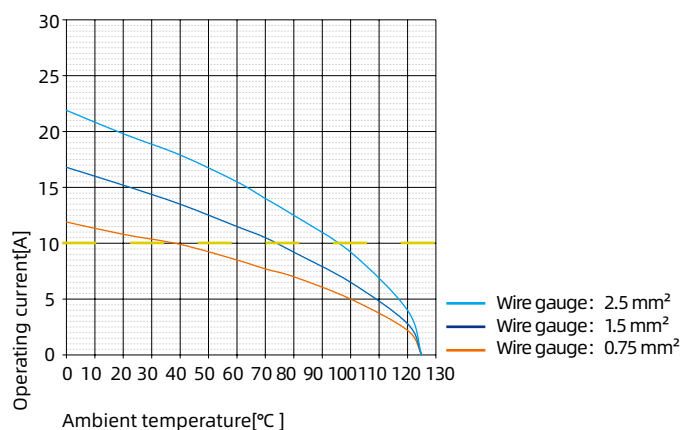

## HQ-012/0 Compact inserts

400V 10A 12+ 



### Inserts

Hoods/Housings: size 3A, please find the details on page 15-06~15-16.1.

Crimp terminal

order crimp contacts separately



Insert	Designation	Order No.
Male	HQ-012/0-MC	130 012 010 0001
Female	HQ-012/0-FC	130 012 020 0001

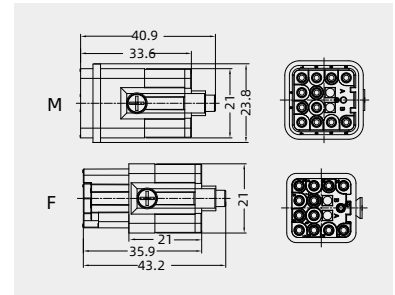

### Accessories

Crimp contacts 10A

Contact resistance  $\leq 3m\Omega$

silver plated



gold plated



More crimp contacts 10A  
see P13-02,P13-03.

Tools



Male	Order No.	Female	Order No.
CDSM-0.25	101 017 110 0101	CDSF-0.25	101 017 120 0101
CDSM-0.37	101 017 110 0301	CDSF-0.37	101 017 120 0301
CDSM-0.50	101 017 110 0401	CDSF-0.50	101 017 120 0401
CDSM-0.75	101 017 110 0601	CDSF-0.75	101 017 120 0601
CDSM-1.0	101 017 110 0801	CDSF-1.0	101 017 120 0801
CDSM-1.5	101 017 110 0901	CDSF-1.5	101 017 120 0901
CDSM-2.5	101 017 110 1001	CDSF-2.5	101 017 120 1001
CDGM-0.25	101 017 210 0101	CDGF-0.25	101 017 220 0101
CDGM-0.37	101 017 210 0301	CDGF-0.37	101 017 220 0301
CDGM-0.50	101 017 210 0401	CDGF-0.50	101 017 220 0401
CDGM-0.75	101 017 210 0601	CDGF-0.75	101 017 220 0601
CDGM-1.0	101 017 210 0801	CDGF-1.0	101 017 220 0801
CDGM-1.5	101 017 210 0901	CDGF-1.5	101 017 220 0901
CDGM-2.5	101 017 210 1001	CDGF-2.5	101 017 220 1001

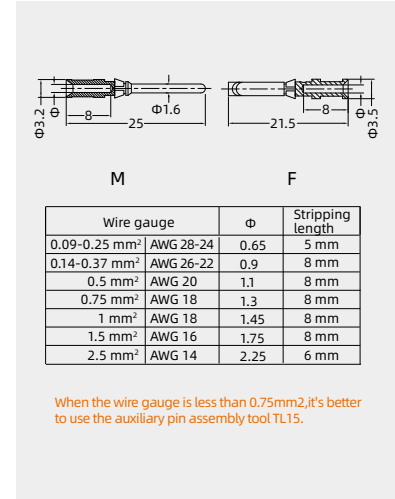

Coding element



Wire gauge	Designation	Order No.
0.14-4mm <sup>2</sup>	TL02G	198 001 001 0011

Application	Designation	Order No.
for crimp contacts 10A	TL00	198 001 000 0001

More tools detail please find the page 32-02~32-05.

Description	Designation	Order No.
coding,pokayoke	CODE-Q12	198 002 005 0010

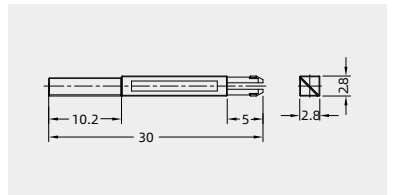
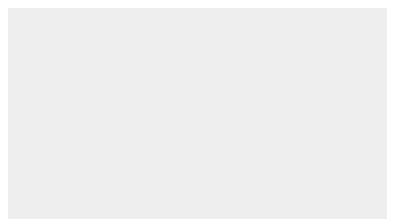

Notes: The tools for crimp terminal may influence the product quality and stability. Please select the tools recognized by our company.

# HQ-008/0 Compact inserts



## Technical characteristics

Specifications	DIN EN 60 664 DIN EN 61 984
Approvals	
Inserts	
Number of contacts	8+PE
Electrical data acc. to EN 61 984	
-Rated current	16A
-Rated voltage	500V
-Rated impulse voltage	6kV
-Pollution degree	3
-Pollution degree 2 also	10A 400/690V 6kV 2
-Mounted metal hood	10A 230/400V 4kV 3
Rated voltage acc. to UL	600V
Insulation resistance	$\geq 10^{10}\Omega$
Material	polycarbonate
Limiting temperatures	-40°C ...+125°C
Flammability acc. to UL 94	V0
Mechanical working life(mating cycles)	$\geq 500$
Contacts	
Material	copper alloy
Surface	hard-silver plated hard-gold plated
Contact resistance	$\leq 1m\Omega$
Crimp terminal	
-mm <sup>2</sup>	0.14-4mm <sup>2</sup> partly loaded up to 4 mm <sup>2</sup> is possible
-AWG	26-12
Hoods/Housings	
Plastic hoods/housings	
Material	thermoplastic
-Locking element	Polyamide
-Hoods/Housings seal	NBR
-Limiting temperatures	-40°C ...+125°C
-Flammability acc. to UL 94	V0
-Degree of protection acc. to DIN EN 60 529 for coupled connector	IP65
Hoods/Housings, metal	
-Material	metal
-Locking element	Stainless steel
-Hoods/Housings seal	NBR
-Limiting temperatures	-40°C ...+125°C
-Degree of protection acc. to DIN EN 60 529 for coupled connector	IP65

## Current carrying capacity

The current carrying is limited by maximum temperature of materials for inserts and contacts including terminals

Control and test procedures according to DIN EN 60512-5

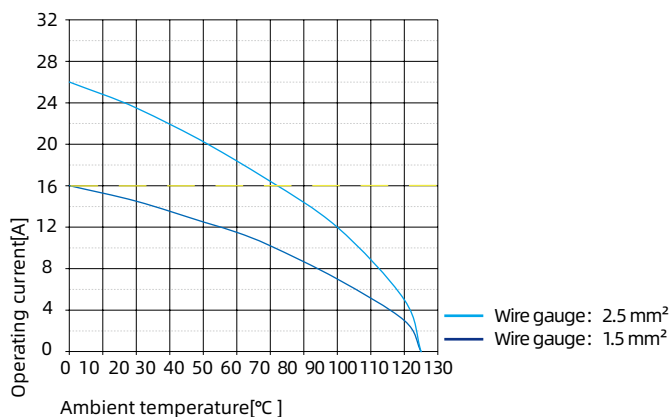

# HQ-008/0 Compact inserts

500V 16A 8+ 



## Inserts

Hoods/Housings: size HC, please find the details on page 15-163~15-168.

Crimp terminal  
order crimp contacts separately



Insert	Designation	Order No.
Male	HQ-008/0-MC <sup>1)</sup>	130 008 010 0001
Female	HQ-008/0-FC <sup>1)</sup>	130 008 020 0001

1).can match PCB adapter,see page 14-10~14-11.

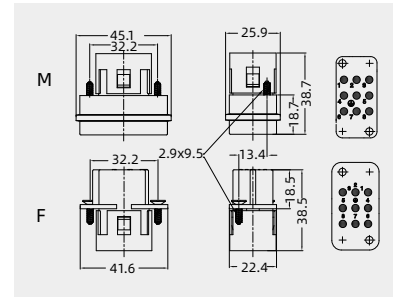

## Crimp contacts

Crimp contacts 16A Contact  
resistance ≤ 1mΩ

silver plated



gold plated



Male	Order No.	Female	Order No.
CESM-0.37	101 019 110 0301	CESF-0.37	101 019 120 0301
CESM-0.50	101 019 110 0401	CESF-0.50	101 019 120 0401
CESM-0.75	101 019 110 0601	CESF-0.75	101 019 120 0601
CESM-1.0	101 019 110 0801	CESF-1.0	101 019 120 0801
CESM-1.5	101 019 110 0901	CESF-1.5	101 019 120 0901
CESM-2.5	101 019 110 1001	CESF-2.5	101 019 120 1001
CESM-3.0	101 019 110 1101	CESF-3.0	101 019 120 1101
CESM-4.0	101 019 110 1201	CESF-4.0	101 019 120 1201
CEGM-0.37	101 019 210 0301	CEGF-0.37	101 019 220 0301
CEGM-0.50	101 019 210 0401	CEGF-0.50	101 019 220 0401
CEGM-0.75	101 019 210 0601	CEGF-0.75	101 019 220 0601
CEGM-1.0	101 019 210 0801	CEGF-1.0	101 019 220 0801
CEGM-1.5	101 019 210 0901	CEGF-1.5	101 019 220 0901
CEGM-2.5	101 019 210 1001	CEGF-2.5	101 019 220 1001
CEGM-3.0	101 019 210 1101	CEGF-3.0	101 019 220 1101
CEGM-4.0	101 019 210 1201	CEGF-4.0	101 019 220 1201

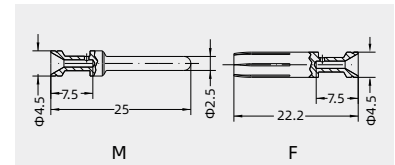

Identification	Wire gauge	Stripping length
no groove	0.14-0.37 mm <sup>2</sup> AWG 26-22	7.5mm
no groove	0.5 mm <sup>2</sup> AWG 20	7.5mm
1 groove	0.75 mm <sup>2</sup> AWG 18	7.5mm
1 groove	1 mm <sup>2</sup> AWG 18	7.5mm
2 groove	1.5 mm <sup>2</sup> AWG 16	7.5mm
3 groove	2.5 mm <sup>2</sup> AWG 14	7.5mm
wide groove	3 mm <sup>2</sup> AWG 12	7.5mm
no groove	4 mm <sup>2</sup> AWG 12	7.5mm

When the wire gauge is less than 0.75mm<sup>2</sup>,it's better to use the auxiliary pin assembly tool TL15.

Relay contacts

silver plated



Wire gauge (mm <sup>2</sup> )	Designation	Order No.
1	CESM-1.0R	101 019 110 0808
1.5	CESM-1.5R	101 019 110 0908
2.5	CESM-2.5R	101 019 110 1008

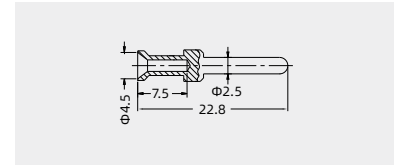

Tools

Crimping tool



Wire gauge	Designation	Order No.
0.14-4mm <sup>2</sup>	TL02G	198 001 001 0011

Wire gauge: 0.14-0.37mm<sup>2</sup>please select TL02 Crimping tool.

Contact removal tool



Application	Designation	Order No.
for crimp contacts16A	TL01	198 001 000 0002

More tools detail please find the page32-02~32-05.

Coding element



Description	Designation	Order No.
coding, pokayoke	CODE-E	198 002 005 0002

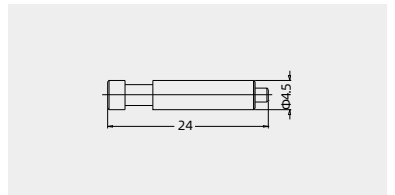
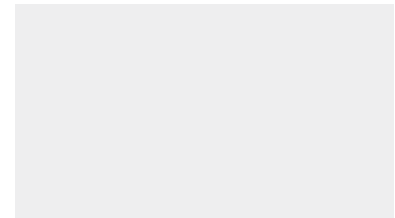

Notes: The tools for crimp terminal may influence the product quality and stability. Please select the tools recognized by our company.

# HQ-017 Compact inserts



## Technical characteristics

Specifications	DIN EN 60 664 DIN EN 61 984
Approvals	<b>UL</b> <b>CE</b> <b>ERC</b> <b>CQC</b>
Inserts	
Number of contacts	17+PE
Electrical data acc. to EN 61 984	
-Rated current	10A
-Rated voltage	250V
-Rated impulse voltage	4kV
-Pollution degree	2
Rated voltage acc. to UL	250V
Insulation resistance	$\geq 10^{10}\Omega$
Material	polycarbonate
Limiting temperatures	-40°C ...+125°C
Flammability acc. to UL 94	V0
Mechanical working life(mating cycles) cycles	$\geq 500$
Contacts	
Material	copper alloy
Surface	hard-silver plated hard-gold plated
Contact resistance	$\leq 3m\Omega$
Crimp terminal	
-mm <sup>2</sup>	0.14-2.5mm <sup>2</sup>
-AWG	26-14
Hoods/Housings	
Plastic hoods/housings	
-Material	thermoplastic
-Locking element	polyamide
-Hoods/Housings seal	NBR
-Limiting temperatures	-40°C ...+125°C
-Flammability acc. to UL 94	V0
-Degree of protection acc. to DIN EN 60 529 for coupled connector	IP65
Hoods/Housings, metal	
-Material	metal
-Locking element	stainless steel
-Hoods/Housings seal	NBR
-Limiting temperatures	-40°C ...+125°C
-Degree of protection acc. to DIN EN 60 529 for coupled connector	IP65

## Current carrying capacity

The current carrying is limited by maximum temperature of materials for inserts and contacts including terminals

Control and test procedures according to DIN EN 60512-5

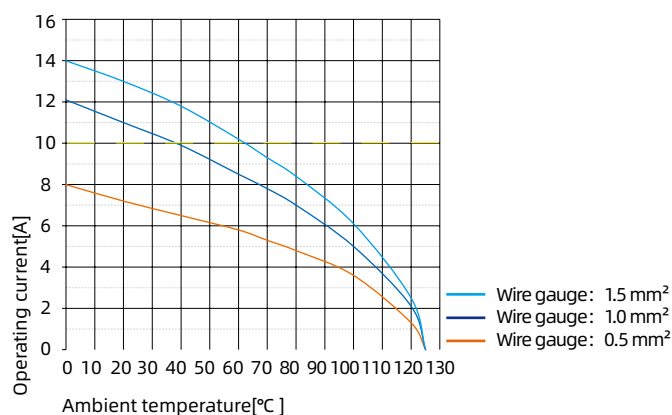

# HQ-017 Compact inserts

250V 10A 17+ 



## Inserts

Hoods/Housings: size HC, please find the details on page 15-163~15-168.

Crimp terminal  
order crimp contacts separately



Insert	Designation	Order No.
Male	HQ-017-MC	130 017 010 0001
Female	HQ-017-FC	130 017 020 0001

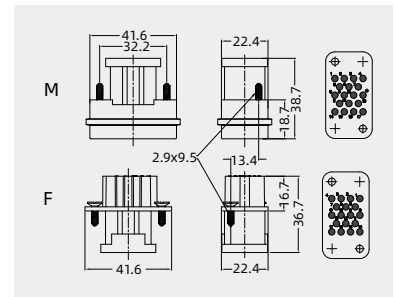

## Accessories

Crimp contacts 10A

Contact resistance  $\leq 3m\Omega$

silver plated



gold plated



More crimp contacts 10A  
see P13-02,P13-03.

Tools



Male	Order No.	Female	Order No.
CDSM-0.25	101 017 110 0101	CDSF-0.25	101 017 120 0101
CDSM-0.37	101 017 110 0301	CDSF-0.37	101 017 120 0301
CDSM-0.50	101 017 110 0401	CDSF-0.50	101 017 120 0401
CDSM-0.75	101 017 110 0601	CDSF-0.75	101 017 120 0601
CDSM-1.0	101 017 110 0801	CDSF-1.0	101 017 120 0801
CDSM-1.5	101 017 110 0901	CDSF-1.5	101 017 120 0901
CDSM-2.5	101 017 110 1001	CDSF-2.5	101 017 120 1001
CDGM-0.25	101 017 210 0101	CDGF-0.25	101 017 220 0101
CDGM-0.37	101 017 210 0301	CDGF-0.37	101 017 220 0301
CDGM-0.50	101 017 210 0401	CDGF-0.50	101 017 220 0401
CDGM-0.75	101 017 210 0601	CDGF-0.75	101 017 220 0601
CDGM-1.0	101 017 210 0801	CDGF-1.0	101 017 220 0801
CDGM-1.5	101 017 210 0901	CDGF-1.5	101 017 220 0901
CDGM-2.5	101 017 210 1001	CDGF-2.5	101 017 220 1001

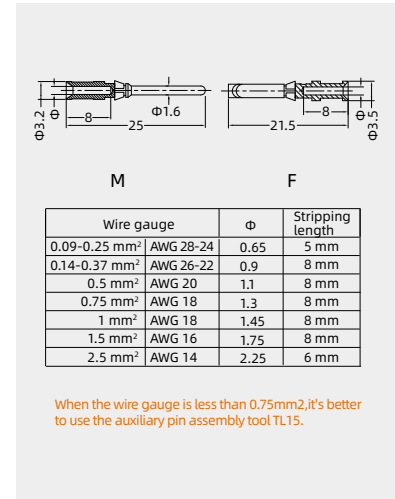

Wire gauge	Designation	Order No.
0.14-4mm <sup>2</sup>	TL02G	198 001 001 0011

Application	Designation	Order No.
for crimp contacts 10A	TL00	198 001 000 0001

More tools detail please find the page32-02~32-05.

Notes: The tools for crimp terminal may influence the product quality and stability. Please select the tools recognized by our company.

## HQ-004/2 Compact inserts



### Technical characteristics

Specifications	DIN EN 60 664 DIN EN 61 984
Approvals	CE ENEC
Inserts	
Number of contacts	4/2+PE
Electrical data acc. to EN 61 984	
Power side	
-Rated current	40A
-Rated voltage conductor - ground	400V
-Rated voltage conductor - conductor	690V
-Rated impulse voltage	6kV
-Pollution degree	3
Signal side	
-Rated current	10A
-Rated voltage	250V
-Rated impulse voltage	4kV
-Pollution degree	3
Rated voltage acc. to UL	600/250V
Insulation resistance	$\geq 10^{10}\Omega$
Material	polycarbonate
Limiting temperatures	-40°C ...+125°C
Flammability acc. to UL 94	V0
Mechanical working life(mating cycles)	$\geq 500$
Contacts	
Material	copper alloy
Surface	hard-silver plated hard-gold plated
Contact resistance	$\leq 1m\Omega$
Crimp terminal	
- mm <sup>2</sup>	1.5-6mm <sup>2</sup> / 0.14-2.5mm <sup>2</sup>
- AWG	16-10 / 26-14
Max. insulation diameter	
- Power contacts	5mm
Hoods/Housings	
Plastic hoods/housings	
Material	thermoplastic
-Locking element	polyamide
-Hoods/Housings seal	NBR
-Limiting temperatures	-40°C ...+125°C
-Flammability acc. to UL 94	V0
-Degree of protection acc. to DIN EN 60 529 for coupled connector	IP65

### Current carrying capacity

The current carrying is limited by maximum temperature of materials for inserts and contacts including terminals

Control and test procedures according to DIN EN 60512-5

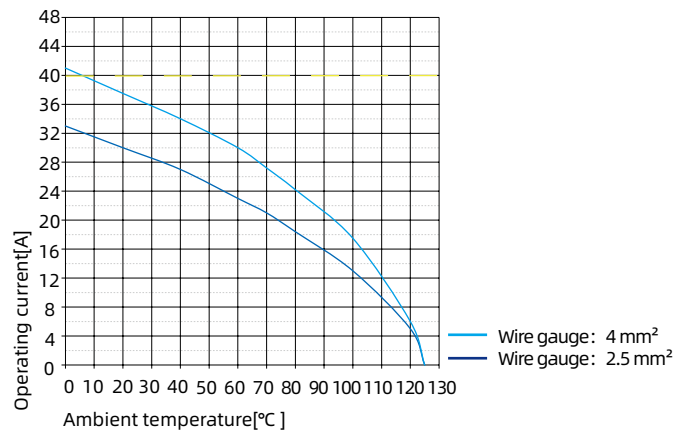

# HQ-004/2 Compact inserts

400/690V 40/10A 4/2+ ⊕

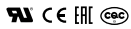

Hoods/Housings: size **HC**, please find the details on page 15-163~15-168.  
(cannot match the metal hood with side entry:130 008 510 1003, 130 608 510 1003)

## Inserts

Crimp terminal  
order crimp contacts separately



Insert	Designation	Order No.
Male	HQ-004/2-MC <sup>1)</sup>	130 006 010 0001
Female	HQ-004/2-FC <sup>1)</sup>	130 006 020 0001

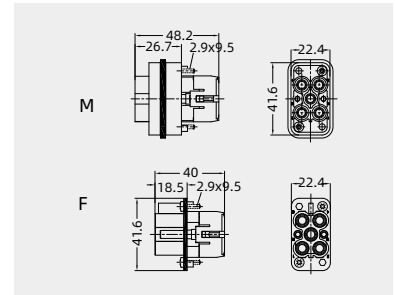

1).can match PCB adapter,see page 14-06~14-07.

## Accessories

Crimp contacts 10A  
Contact resistance ≤ 3mΩ

silver plated



Male	Order No.	Female	Order No.
CDSM-0.25	101 017 110 0101	CDSF-0.25	101 017 120 0101
CDSM-0.37	101 017 110 0301	CDSF-0.37	101 017 120 0301
CDSM-0.50	101 017 110 0401	CDSF-0.50	101 017 120 0401
CDSM-0.75	101 017 110 0601	CDSF-0.75	101 017 120 0601
CDSM-1.0	101 017 110 0801	CDSF-1.0	101 017 120 0801
CDSM-1.5	101 017 110 0901	CDSF-1.5	101 017 120 0901
CDSM-2.5	101 017 110 1001	CDSF-2.5	101 017 120 1001

gold plated



Male	Order No.	Female	Order No.
CDGM-0.25	101 017 210 0101	CDGF-0.25	101 017 220 0101
CDGM-0.37	101 017 210 0301	CDGF-0.37	101 017 220 0301
CDGM-0.50	101 017 210 0401	CDGF-0.50	101 017 220 0401
CDGM-0.75	101 017 210 0601	CDGF-0.75	101 017 220 0601
CDGM-1.0	101 017 210 0801	CDGF-1.0	101 017 220 0801
CDGM-1.5	101 017 210 0901	CDGF-1.5	101 017 220 0901
CDGM-2.5	101 017 210 1001	CDGF-2.5	101 017 220 1001

More crimp contacts 10A  
see P13-02,P13-03.

Crimp contacts 40A

Contact resistance ≤ 1mΩ

silver plated



Male	Order No.	Female	Order No.
CCSM-1.5	101 023 110 0901	CCSF-1.5	101 023 120 0901
CCSM-2.5	101 023 110 1001	CCSF-2.5	101 023 120 1001
CCSM-4.0	101 023 110 1201	CCSF-4.0	101 023 120 1201
CCSM-6.0	101 023 110 1301	CCSF-6.0	101 023 120 1301

## Tools

Crimping tool



Wire gauge	Designation	Order No.
0.14-4mm <sup>2</sup>	TL02G	198 001 001 0011
1.5-6mm <sup>2</sup>	TL02-0G	198 001 001 0012

Contact removal tool



Application	Designation	Order No.
for crimp contacts 10A	TL00	198 001 000 0001
for crimp contacts 40A	TL06G	198 001 000 0009

More tools detail please find the page32-02~32-05.

Wire gauge	Φ	Stripping length
0.09-0.25 mm <sup>2</sup>	AWG 28-24	0.65 5 mm
0.14-0.37 mm <sup>2</sup>	AWG 26-22	0.9 8 mm
0.5 mm <sup>2</sup>	AWG 20	1.1 8 mm
0.75 mm <sup>2</sup>	AWG 18	1.3 8 mm
1 mm <sup>2</sup>	AWG 18	1.45 8 mm
1.5 mm <sup>2</sup>	AWG 16	1.75 8 mm
2.5 mm <sup>2</sup>	AWG 14	2.25 6 mm

When the wire gauge is less than 0.75mm<sup>2</sup>,it's better to use the auxiliary pin assembly tool TL15.

Wire gauge	Φ	Stripping length
1.5 mm <sup>2</sup>	AWG 16	1.75 9 mm
2.5mm <sup>2</sup>	AWG 14	2.25 9 mm
4 mm <sup>2</sup>	AWG 12	2.85 9.6 mm
6 mm <sup>2</sup>	AWG 10	3.5 9.6 mm
10 mm <sup>2</sup>	AWG 8	4.3 15 mm

Notes: The tools for crimp terminal may influence the product quality and stability. Please select the tools recognized by our company.



## HQ-RJ45/10 High Density inserts

### Technical characteristics

Specifications	DIN EN 60 664 DIN EN 61 984
Approvals	
Inserts	
Number of contacts	10+RJ45
Electrical data acc. to EN 61 984	
-Rated current	5A
	1A
-Rated voltage	50V
-Rated impulse voltage	0.8kV
-Pollution degree	3
Insulation resistance	$\geq 10^{10}\Omega$
Material	polycarbonate
Limiting temperatures	-40°C ...+85°C
Flammability acc. to UL 94	V0
Mechanical working life(mating cycles)	$\geq 500$
Transmission characteristics:	over 6 type jumper up to 500MHz According to ISO/IEC 24 702; ISO/IEC 11 801
Transmission rate:	10/100/1000Mbit/10Gbit/s
Contacts	
Material	copper alloy
Surface	hard-silver plated/hard-gold plated
Contact resistance	$\leq 3m\Omega$
Crimp terminal	
-mm <sup>2</sup>	0.09-0.52mm <sup>2</sup>
-AWG	28-20

# HQ-RJ45/10 High Density inserts

50V 5/1A 10+RJ45

Hoods/Housings: size HC, please find the details on page 15-163~15-168.  
Please refer to page 10-50 for matching cable (no plastic cable)

## Inserts

Crimp terminal  
order crimp contacts separately



Insert	Designation	Order No.
Male	HQ-RJ45/10-MC	130 000 010 0001
Female	HQ-RJ45/10-FC	130 000 020 0001

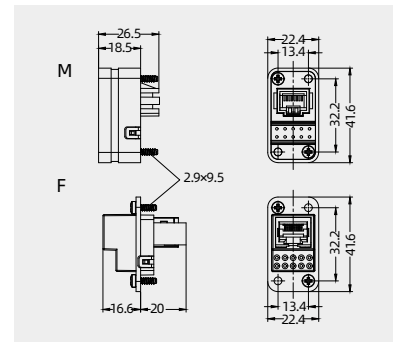

## Crimp contacts

Crimp contacts 5A

Contact resistance  $\leq 3m\Omega$   
silver plated



gold plated



Male	Order No.	Female	Order No.
CSSM-0.25	101 014 110 0101	CSSF-0.25	101 014 120 0101
CSSM-0.33	101 014 110 0201	CSSF-0.33	101 014 120 0201
CSSM-0.52	101 014 110 0501	CSSF-0.52	101 014 120 0501

Male	Order No.	Female	Order No.
CSGM-0.25	101 014 210 0101	CSGF-0.25	101 014 220 0101
CSGM-0.33	101 014 210 0201	CSGF-0.33	101 014 220 0201
CSGM-0.52	101 014 210 0501	CSGF-0.52	101 014 220 0501

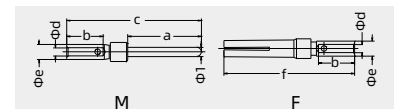

a	b	c	d	e	f
8.10	4.0	14.8	0.64	1.66	14.4
8.10	4.0	14.8	0.90	1.66	14.4
8.10	4.0	14.8	1.12	1.66	14.4

Wire gauge	Stripping length
0.09-0.25 mm <sup>2</sup>	AWG 28-24
0.13-0.33 mm <sup>2</sup>	AWG 26-22
0.33-0.52 mm <sup>2</sup>	AWG 22-20

Stamped contacts 5A

Contact resistance  $\leq 10m\Omega$   
silver plated



gold plated



coil stock



Note: 10kpcs/volume

Male	Order No.	Female	Order No.
CSSM-0.82P	101 014 110 0750	CSSF-0.82P	101 014 120 0750
CSGM-0.82P	101 014 210 0750	CSGF-0.82P	101 014 220 0750

Tools

Crimping tool



Contact removal tool



Wire gauge	Designation	Order No.
0.09-0.82mm <sup>2</sup>	TL03	198 001 001 0002

Application	Designation	Order No.
for crimp contacts 5A	TL08	198 001 000 0006

Notes: The tools for crimp terminal may influence the product quality and stability. Please select the tools recognized by our company.

# HQ-021 High Density inserts

## Technical characteristics

Specifications	DIN EN 60 664 DIN EN 61 984
Approvals	
Inserts	
Number of contacts	21
Electrical data acc. to EN 61 984	
-Rated current	6.5A
-Rated voltage	50V
-Rated impulse voltage	0.8kV
-Pollution degree	3
Rated voltage AC	50 V
Rated voltage DC	120 V
Insulation resistance	$\geq 10^{10}\Omega$
Material	polycarbonate
Limiting temperatures	-40°C ...+125°C
Flammability acc. to UL 94	V0
Mechanical working life(mating cycles)	$\geq 500$
Contacts	
Material	copper alloy
Surface	hard-silver plated
	hard-gold plated
Contact resistance	$\leq 3m\Omega$
Crimp terminal	
-mm <sup>2</sup>	0.09-0.52mm <sup>2</sup>
-AWG	28-20

## Current carrying capacity

The current carrying is limited by maximum temperature of materials for inserts and contacts including terminals

Control and test procedures according to DIN EN 60512-5

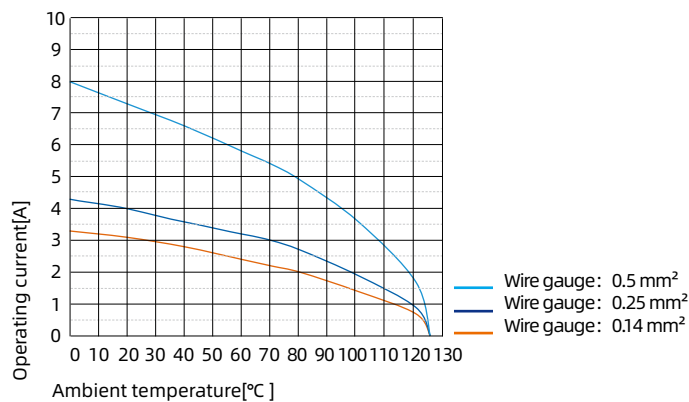

# HQ-021 High Density inserts

50V 6.5A 21

## Inserts

Hoods/Housings: size 3A, please find the details on page 15-06~15-16.1.

### Crimp terminal

order crimp contacts separately



Insert	Designation	Order No.
Male	HQ-021-MC	130 021 010 0001
Female	HQ-021-FC	130 021 020 0001

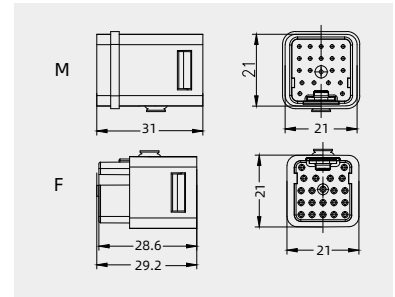

## Crimp contacts

### Crimp contacts 5A

Contact resistance  $\leq 3m\Omega$   
silver plated



gold plated



Male	Order No.	Female	Order No.
CSSM-0.25	101 014 110 0101	CSSF-0.25	101 014 120 0101
CSSM-0.33	101 014 110 0201	CSSF-0.33	101 014 120 0201
CSSM-0.52	101 014 110 0501	CSSF-0.52	101 014 120 0501

Male	Order No.	Female	Order No.
CSGM-0.25	101 014 210 0101	CSGF-0.25	101 014 220 0101
CSGM-0.33	101 014 210 0201	CSGF-0.33	101 014 220 0201
CSGM-0.52	101 014 210 0501	CSGF-0.52	101 014 220 0501

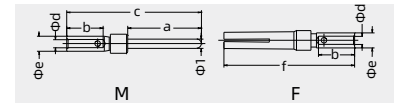

a	b	c	d	e	f
8.10	4.0	14.8	0.64	1.66	14.4
8.10	4.0	14.8	0.90	1.66	14.4
8.10	4.0	14.8	1.12	1.66	14.4

Wire gauge	Stripping length
0.09-0.25 mm <sup>2</sup>	AWG 28-24
0.13-0.33 mm <sup>2</sup>	AWG 26-22
0.33-0.52 mm <sup>2</sup>	AWG 22-20

### Stamped contacts 5A

Contact resistance  $\leq 10m\Omega$   
silver plated



gold plated



coil stock



Note: 10kpcs/volume

Male	Order No.	Female	Order No.
CSSM-0.82P	101 014 110 0750	CSSF-0.82P	101 014 120 0750

Male	Order No.	Female	Order No.
CSGM-0.82P	101 014 210 0750	CSGF-0.82P	101 014 220 0750

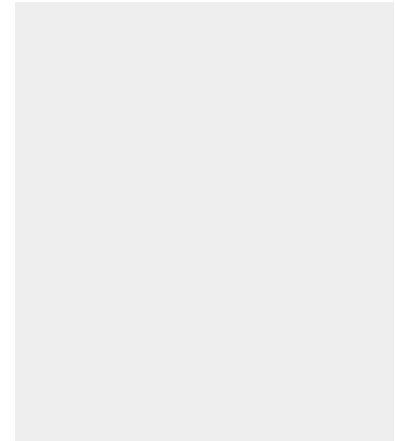

### Tools

Crimping tool



Contact removal tool



Wire gauge	Designation	Order No.
0.09-0.82mm <sup>2</sup>	TL03	198 001 001 0002

Application	Designation	Order No.
for crimp contacts 5A	TL08	198 001 000 0006

Notes: The tools for crimp terminal may influence the product quality and stability. Please select the tools recognized by our company.



# HK-003, HC SERIES

Modular Heavy-current connector



## HK-003/0, HK-003/2 Heavy-current inserts



### Technical characteristics

Specifications	DIN EN 60 664 DIN EN 61 984
Approvals	CE
<b>Inserts</b>	
Number of contacts	3/0+PE,3/2+PE
Electrical data acc. to EN 61 984	
<b>Power area</b>	
-Rated current	200A
-Rated voltage conductor	1150/2000V
-Rated impulse voltage	8kV
-Pollution degree	3
Pollution degree 2 also	200A 2000V 12kV 2
<b>Signal area</b>	
-Rated current	16A
-Rated voltage	400V
-Rated impulse voltage	6kV
-Pollution degree	3
Pollution degree 2 also	16A 500V 6kV 2
Insulation resistance	$\geq 10^{10}\Omega$
Material	polycarbonate
Limiting temperatures	-40°C ...+125°C
Flammability acc. to UL 94	V0
Mechanical working life(mating cycles)	$\geq 500$
<b>Contacts</b>	
Material	copper alloy
Surface	silver
Contact resistance	$\leq 0.2m\Omega$
For stranded wire acc. to IEC 60 228 Class 5	
<b>Axial screw termination</b>	
<b>Power contacts</b>	
- Wire gauge	35-70mm <sup>2</sup>
- AWG	2-00
- Hexagonal driver	SW5
- Stripping length	22mm
	mm <sup>2</sup> 35 50 70
- Tightening torque	N.m 8 9 10
<b>PE contact</b>	
- Wire gauge	16-35mm <sup>2</sup>
- AWG	5-2
- Hexagonal driver	SW4
- Stripping length	14mm
- Tightening torque	6Nm
<b>Signal contact (only HK 3/2)</b>	
- Wire gauge	2.5mm <sup>2</sup>
- AWG	14
- Stripping length	7mm
- Tightening torque	0.5Nm

### Current carrying capacity

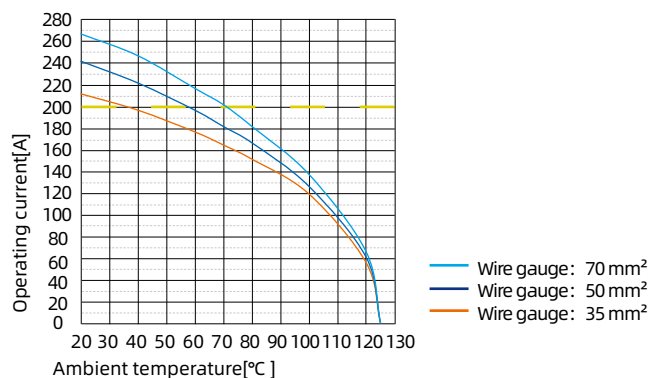

The current carrying is limited by maximum temperature of materials for inserts and contacts including terminals

Control and test procedures according to DIN EN 60512-5



24B Pressure tight hoods/housings with 1 modules

HK-003/0, HK-003/2 Heavy-current inserts

1150/2000V 200A 3/0  , 3/2+ 

CE

Inserts

Hoods/Housings: size Pressure tight hoods/housings, please find the details on page 12-04~12-05.

Axial screw terminal <sup>1)</sup>



Insert	Designation	Order No.
Male	HK-003/0-M	128 003 011 0001
Female	HK-003/0-F	128 003 021 0001

Axial screw terminal <sup>1)</sup>



Insert	Designation	Order No.
Male	HK-003/2-M	128 005 011 0001
Female	HK-003/2-F	128 005 021 0001

Distance for contact max. 21 mm

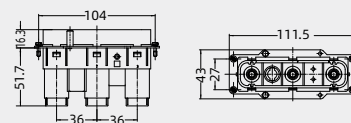

M

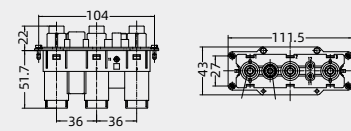

F



Pressure tight hoods/housings

Degree of protection: IP68/IP69K

H version

Hoods, top entry, high construction



Thread	Designation	Order No.
	Screw locking	
3M25	HP24B/H-TEH-2S-3M25	113 624 420 5036
3M25,M20	HP24B/H-TEH-2S-3M25M20	113 624 420 5040
	Toggle locking	
3M25	HP24B/H-TEH-2T-3M25	113 624 440 5036
3M25,M20	HP24B/H-TEH-2T-3M25M20	113 624 440 5040

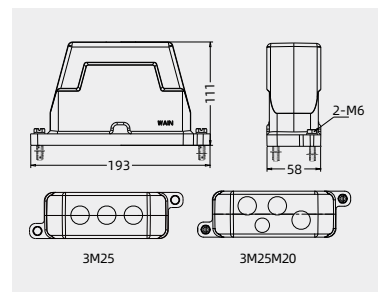

Hoods, top entry, high construction



Thread	Designation	Order No.
	Screw locking	
M63	HP24B/H-TEH-2S-M63	113 624 420 5007
	Toggle locking	
M63	HP24B/H-TEH-2T-M63	113 624 440 5007

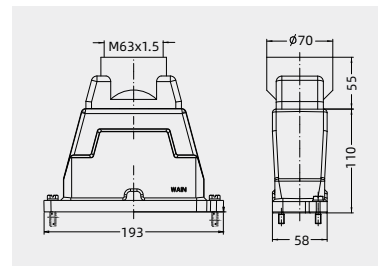

Surface mounted housings high construction



Thread	Designation	Order No.
	Screw locking	
3M25	HP24B/H-SFH-2H-3M25	113 624 220 5036
3M25,M20	HP24B/H-SFH-2H-3M25M20	113 624 220 5040
	Toggle locking	
3M25	HP24B/H-SFH-2T-3M25	113 624 240 5036
3M25,M20	HP24B/H-SFH-2T-3M25M20	113 624 240 5040

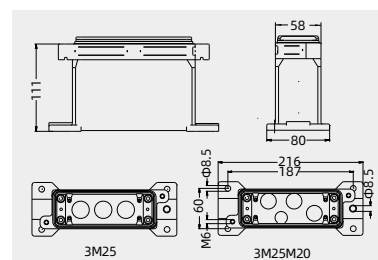

Surface mounted housings high construction



Thread	Designation	Order No.
	Screw locking	
3M25	HP24B/H-BK-SE-2H-3M25	113 624 920 1036
3M25,M20	HP24B/H-BK-SE-2H-3M25M20	113 624 920 1040
M50	HP24B/H-BK-SE-2H-M50	113 624 920 1006
	Toggle locking	
3M25	HP24B/H-BK-SE-2T-3M25	113 624 940 1036
3M25,M20	HP24B/H-BK-SE-2T-3M25M20	113 624 940 1040
M50	HP24B/H-BK-SE-2T-M50	113 624 940 1006

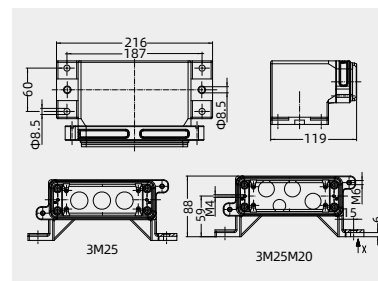

Surface mounted housings



Thread	Designation	Order No.
	Screw locking	
---	HP24B/H-BK-2H	113 624 320 1001
	Toggle locking	
---	HP24B/H-BK-2T	113 624 340 1001

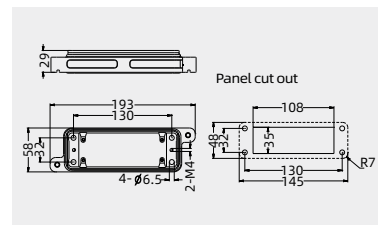

## Pressure tight hoods/housings

Degree of protection: IP68/IP69K

The following hoods/housings comply with the standards for rail transport industry in China.

H version

### Hoods, top entry, high construction



Thread	Designation	Order No.
	Screw locking	
3M25	HP24B/H-TEH-4S-3M25	113 624 430 5036
3M25,M20	HP24B/H-TEH-4S-3M25M20 3SP	113 624 430 5040

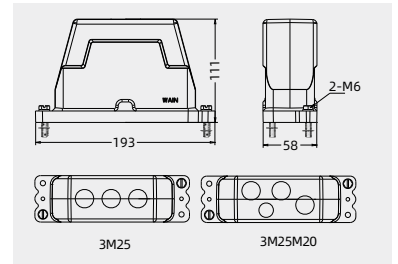

### Hoods, top entry, high construction



Thread	Designation	Order No.
	Screw locking	
M63	HP24B/H-TEH-4S-M63	113 624 430 5007

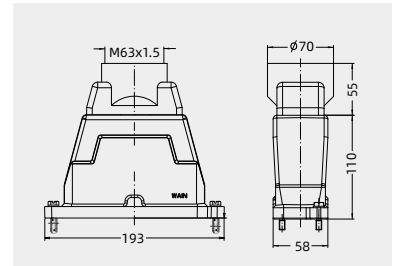

### Surface mounted housings high construction



Thread	Designation	Order No.
	Screw locking	
3M25	HP24B/H-SFH/BK-4H-3M25	113 624 230 5036
3M25,M20	HP24B/H-SFH-4H-3M25M20	113 624 230 5040

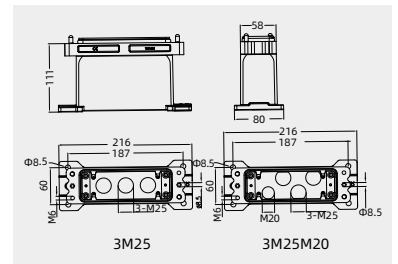

### Surface mounted housings high construction



Thread	Designation	Order No.
	Screw locking	
3M25	HP24B/H-BK-SE-4H-3M25	113 624 930 1036
3M25,M20	HP24B/H-BK-SE-4H-3M25M20	113 624 930 1040
M50	HP24B/H-BK-SE-4H-M50	113 624 930 1006

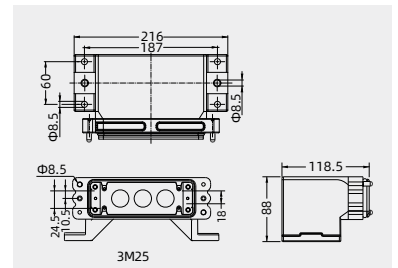

### Surface mounted housings



Thread	Designation	Order No.
	Screw locking	
---	HP24B/H-BK-4H	113 624 330 1001

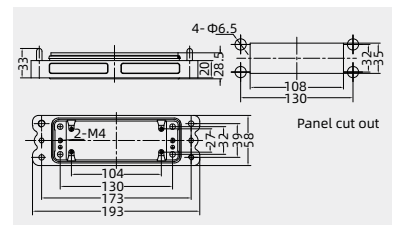

# HC-250 Heavy-current inserts

## Crimp terminal



### Technical characteristics

Specifications	DIN EN 60 664 DIN EN 61 984
Approvals	
<b>Inserts</b>	
Number of contacts	1,2,3,4,3+PE
Electrical data acc. to DIN EN 61 984	
Rated current	250A
-Rated voltage	2000V
-Rated impulse voltage	12kV
-Pollution degree	3
Insulation resistance	$\geq 10^{10}\Omega$
Material	polycarbonate
Limiting temperatures	-40°C ...+125°C
Flammability acc. to UL 94	V0
Mechanical working life(mating cycles)	$\geq 500$
<b>Contacts</b>	
Material	Copper alloy
Surface	hard-silver plated
Contact resistance	$\leq 0.3\text{ m}\Omega$
<b>Crimp terminal</b>	
- mm <sup>2</sup>	35 - 70 mm <sup>2</sup>
Max. insulation diameter	18 mm
Crimp dies	acc. to DIN 46 325
Pressing force requirement	130 kN
<b>Frame</b>	
Material	stainless steel
Tightening torque of the M3 fixing screws	0.5Nm

### Current carrying capacity

The current carrying is limited by maximum temperature of materials for inserts and contacts including terminals

Control and test procedures according to DIN EN 60512-5

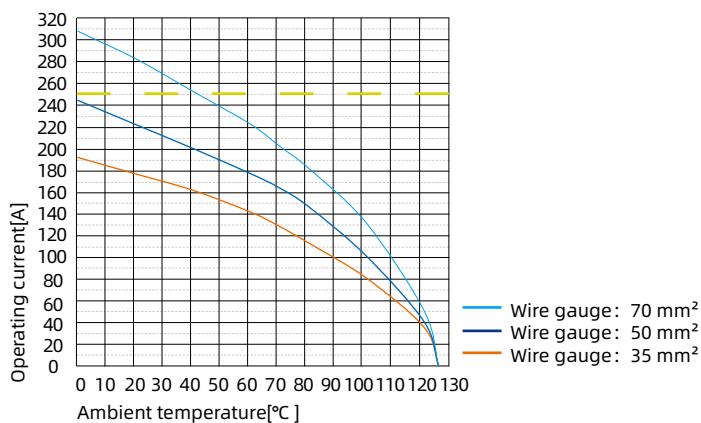

### Assembly Details

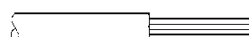

Cut the cable head square and strip the insulation

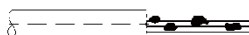

The copper strands must be cleaned from dirt and oxide film



Copper strands must not be twisted

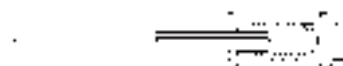

Check if the cable strand is inserted completely into the crimp ferrule of the contact

# HC-250 Heavy-current inserts

2000V 250A



## Inserts

Hoods/Housings: size Pressure tight hoods/housings, please find the details on page 12-08~12-09.

### Crimp terminal

Order crimp contacts separately



Insert	Designation	Order No.
Male	HC250-MC	131 001 010 0001
Female	HC250-FC	131 001 020 0001

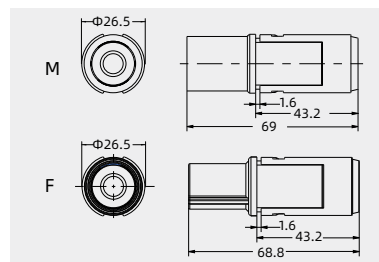

## Crimp contacts

### Crimp contacts 250A

Silver plated



NO.	Male	Order No.	Female	Order No.
①	CHSM250-35	101 028 110 1701	CHSF250-35G	101 028 120 1703
②	CHSM250-50	101 028 110 1801	CHSF250-50G	101 028 120 1803
③	CHSM250-70	101 028 110 1901	CHSF250-70G	101 028 120 1903

For stranded wire acc. to IEC 60 228-5  
Crimp zone acc. to DIN 46 235

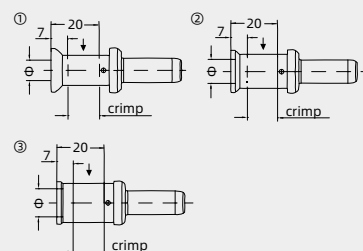

NO.	Wire gauge	Φ	Stripping length
①	35 mm <sup>2</sup>	8.45 mm	22 mm
②	50 mm <sup>2</sup>	10.25 mm	22 mm
③	70 mm <sup>2</sup>	11.75 mm	22 mm

### PE crimp contacts 250A

Silver plated



Male	Order No.	Female	Order No.
CHSM250PE-35	101 028 110 1704	CHSF250PE-35	101 028 120 1704

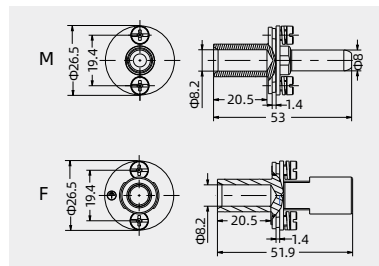

### Tools

Manual hydraulic clamp

Wire gauge	Designation	Order No.
10-240mm <sup>2</sup>	TL05	198 001 001 0005



Notes: The tools for crimp terminal may influence the product quality and stability. Please select the tools recognized by our company.

# Pressure tight hoods/housings

Degree of protection: IP68/IP69K

H version

### Hoods, top entry, high construction



Thread	Designation	Order No.
	Screw locking	
4M20	HP24B/H-TEH-2S-4M20	113 624 420 5038
4M25	HP24B/H-TEH-2S-4M25	113 624 420 5039
	Toggle locking	
4M20	HP24B/H-TEH-2T-4M20	113 624 440 5038
4M25	HP24B/H-TEH-2T-4M25	113 624 440 5039

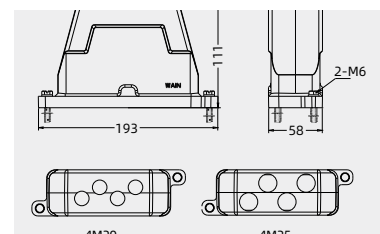

### Surface mounted housings high construction



Thread	Designation	Order No.
	Screw locking	
4M20	HP24B/H-SFH-2H-4M20	113 624 220 5038
4M25	HP24B/H-SFH-2H-4M25	113 624 220 5039
	Toggle locking	
4M20	HP24B/H-SFH-2T-4M20	113 624 240 5038
4M25	HP24B/H-SFH-2T-4M25	113 624 240 5039

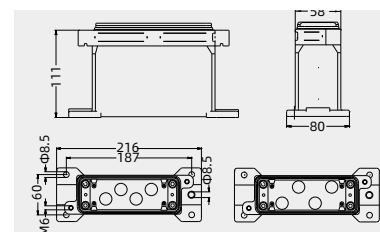

### Surface mounted housings



Thread	Designation	Order No.
	Screw locking	
4M20	HP24B/H-BK-SE-2H-4M20	113 624 920 1038
4M25	HP24B/H-BK-SE-2H-4M25	113 624 920 1039
	Toggle locking	
4M20	HP24B/H-BK-SE-2T-4M20	113 624 940 1038
4M25	HP24B/H-BK-SE-2T-4M25	113 624 940 1039

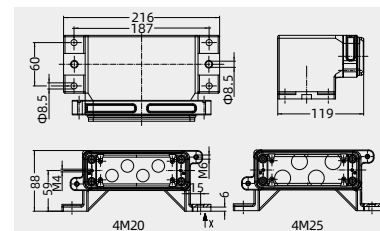

### Bulkhead mounted housings



Thread	Designation	Order No.
	Screw locking	
---	HP24B/H-BK-2H	113 624 320 1001
	Toggle locking	
---	HP24B/H-BK-2T	113 624 340 1001

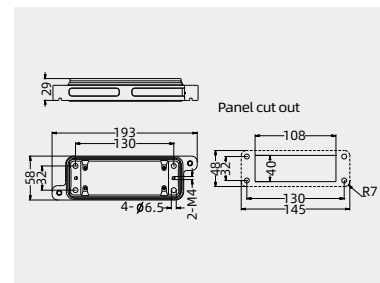

### Frame

for 4 pins



Describe	Designation	Order No.
---	HF24B-004A-M	131 024 000 1011
---	HF24B-004A-F	131 024 000 1012

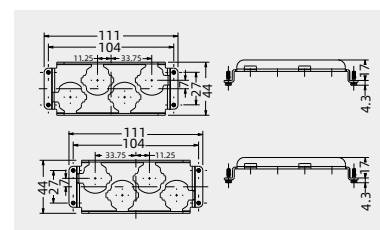

Pressure tight hoods/housings

Degree of protection: IP68/IP69K

The following hoods/housings comply with the standards for rail transport industry in China.

H version

Hoods, top entry, high construction



Thread	Designation	Order No.
	Screw locking	
4M20	HP24B/H-TEH-4S-4M20	113 624 430 5038
4M25	HP24B/H-TEH-4S-4M25	113 624 430 5039

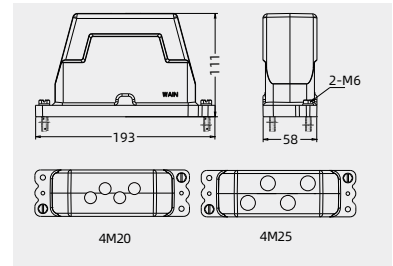

Surface mounted housings high construction



Thread	Designation	Order No.
	Screw locking	
4M20	HP24B/H-SFH-4H-4M20	113 624 230 5038
4M25	HP24B/H-SFH-4H-4M25	113 624 230 5039

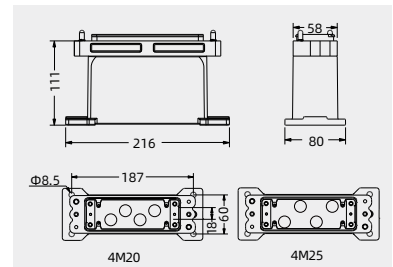

Surface mounted housings



Thread	Designation	Order No.
	Screw locking	
4M20	HP24B/H-BK-SE-4H-4M20	113 624 930 1038
4M25	HP24B/H-BK-SE-4H-4M25	113 624 930 1039

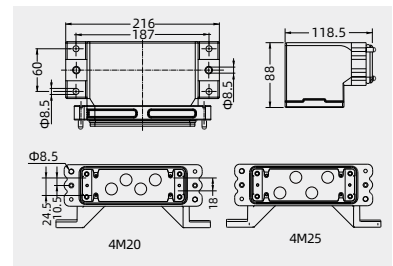

Bulkhead mounted housings



Thread	Designation	Order No.
	Screw locking	
---	HP24B/H-BK-4H	113 624 330 1001

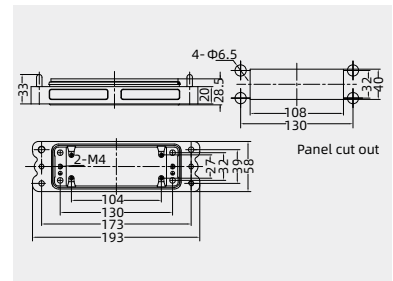

Frame

for 4 pins



Describe	Designation	Order No.
---	HF24B-004A-M	131 024 000 1011
---	HF24B-004A-F	131 024 000 1012

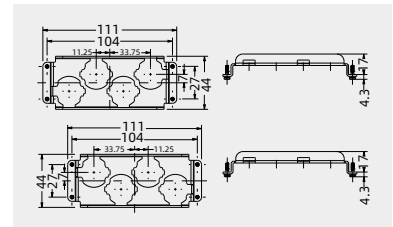

## Pressure tight hoods/housings

Degree of protection: IP68/IP69K

The following hoods/housings comply with the standards for rail transport industry in China.

Only suitable for cable with 18mm diameter

H version

### Hoods, top entry, high construction



Thread	Designation	Order No.
	Screw locking	
4M25	HP16B/HE-TEHH-4S-4M25	113 016 430 5003

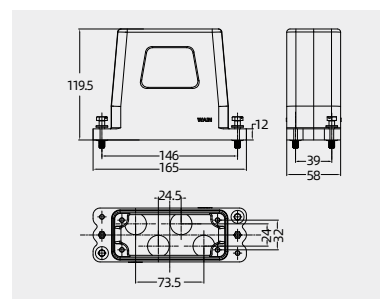

### Bulkhead mounted housings



Thread	Designation	Order No.
	Screw locking	
---	HP16B/HE-BK-4H	113 016 330 1002

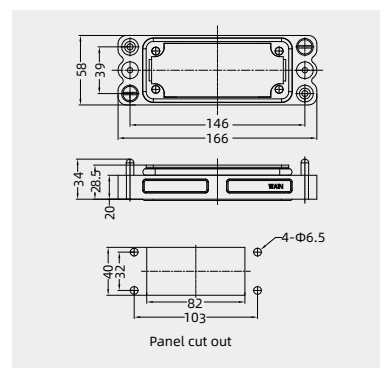

### Frame

for 4 pins



Describe	Designation	Order No.
---	HF16B-004A/E-M	131 016 000 1006
---	HF16B-004A/E-F	131 016 000 1007

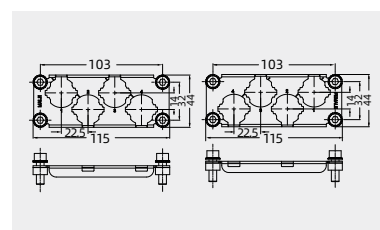

# HC-350 Heavy-current inserts

## Crimp terminal



### Technical characteristics

Specifications	DIN EN 60 664	DIN EN 61 984
Approvals		
Inserts		
Number of contacts	1,2,3,4	
Electrical data acc. to EN 61 984		
without adapter		
-Rated current	350A	
-Rated voltage	2000V	
-Rated impulse voltage	12kV	
-Pollution degree	3	
with adapter		
-Rated voltage	4000V	
-Rated impulse voltage	18kV	
-Pollution degree	3	
Insulation resistance	$\geq 10^{10}\Omega$	
Material	polyamide	
Limiting temperatures	-40°C ...+125°C	
Flammability acc. to UL 94	V0	
Mechanical working life(mating cycles)	$\geq 500$	
Contacts		
Material	copper alloy	
Surface	hard-silver plated	
Contact resistance	$\leq 0.3m\Omega$	
Crimp terminal		
- mm <sup>2</sup>	35 - 120 mm <sup>2</sup>	
Max. insulation diameter	22 mm	
Crimp dies	acc. to DIN 46 235	
Pressing force	130kN	
Frame		
Material	stainless steel	
Tightening torque of the M3 fixing screws	0.5 Nm	
Tightening torque of the M4 fixing screws	1.5 Nm	
Tightening torque of the M6 fixing screws	4Nm	

### Current carrying capacity

The current carrying is limited by maximum temperature of materials for inserts and contacts including terminals

Control and test procedures according to DIN EN 60512-5

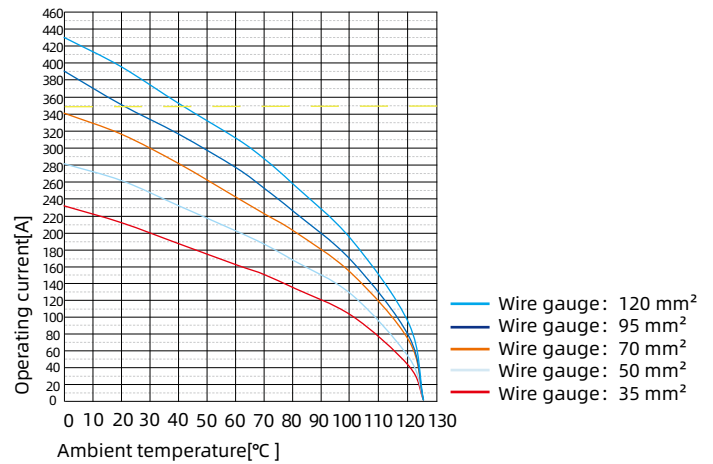

24B Pressure tight hoods/housings with 3 modules

### Assembly Details

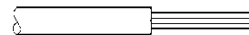

Cut the cable head square and strip the insulation

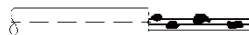

The copper strands must be cleaned from dirt and oxide film



Copper strands must not be twisted

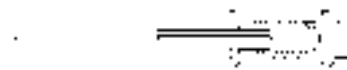

Check if the cable strand is inserted completely into the crimp ferrule of the contact



# HC-350 Heavy-current inserts

2000/4000V 350A



## Inserts

Hoods/Housings: size Pressure tight hoods/housings, please find the details on page 12-12~12-19.

### Crimp terminal

Order crimp contacts separately



Insert	Designation	Order No.
Male	HC350-MC	131 001 010 0101
Female	HC350-FC	131 001 020 0101

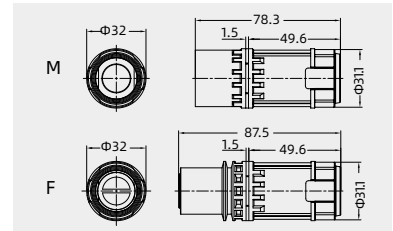

## Crimp contacts

### Crimp contacts 350A

Silver plated



NO.	Male	Order No.	Female	Order No.
①	CHSM350-35	101 029 110 1701	CHSF350-35G	101 029 120 1703
②	CHSM350-50	101 029 110 1801	CHSF350-50G	101 029 120 1803
③	CHSM350-70	101 029 110 1901	CHSF350-70G	101 029 120 1903
④	CHSM350-95	101 029 110 2001	CHSF350-95G	101 029 120 2003
⑤	CHSM350-120	101 029 110 2101	CHSF350-120G	101 029 120 2103

For stranded wire acc. to IEC 60 228-5  
Crimp zone acc. to DIN 46 235

NO.	Wire gauge	Φ	Stripping length
①	35 mm <sup>2</sup>	8.2 mm	26 mm
②	50 mm <sup>2</sup>	10.0 mm	28 mm
③	70 mm <sup>2</sup>	11.5 mm	28 mm
④	95 mm <sup>2</sup>	13.5 mm	30 mm
⑤	120 mm <sup>2</sup>	15.5 mm	24 mm

### Tools

Manual hydraulic clamp



Wire gauge	Designation	Order No.
10-240mm <sup>2</sup>	TL05	198 001 001 0005

### Hexagonal adapter [optional]

metal version  
with O-Ring



Describe	Designation	Order No.
for 350 Hoods/Housings	WNSC-M25M25/APT	102 103 018 1001
	WNSC-M32M32/APT	102 103 019 1001

	WNSC-M25M25/APT	WNSC-M32M32/APT
Thread(LG)	M25x1.5	M32x1.5
Thread(AG)	M25x1.5	M32x1.5
length of thread(L1)	13.5	16.5
length of thread(L2)	5.5	5.5
Wrench Size(SW)	30	40

Notes: The tools for crimp terminal may influence the product quality and stability. Please select the tools recognized by our company.

Pressure tight hoods/housings

Degree of protection: IP68/IP69K

H version

Hoods, top entry, high construction



Thread	Designation	Order No.
	Screw locking	
M25	HP6B/H-TEH-2S-M25	113 606 420 5003
M32	HP6B/H-TEH-2S-M32	113 606 420 5004
	Toggle locking	
M25	HP6B/H-TEH-2T-M25	113 606 440 5003
M32	HP6B/H-TEH-2T-M32	113 606 440 5004

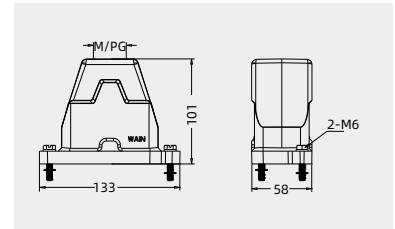

Frame, size 6B hoods/housings

for 1 pins



Describe for 1 pin	Designation	Order No.
	HF6B-001C	131 006 000 1001

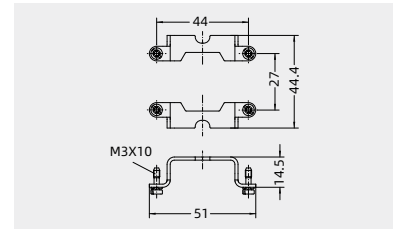

Bulkhead mounted housings



Thread	Designation	Order No.
	Screw locking	
---	HP6B/H-BK-2H	113 606 320 1001
	Toggle locking	
---	HP6B/H-BK-2T	113 606 340 1001

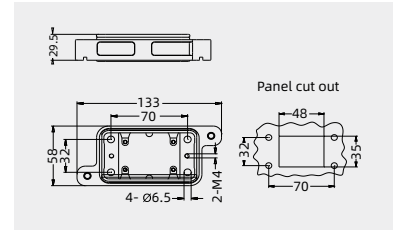

Hoods, top entry, high construction



Thread	Designation	Order No.
	Screw locking	
2M25	HP16B/H-TEH-2S-2M25	113 616 420 5023
	Toggle locking	
2M25	HP16B/H-TEH-2T-2M25	113 616 440 5023

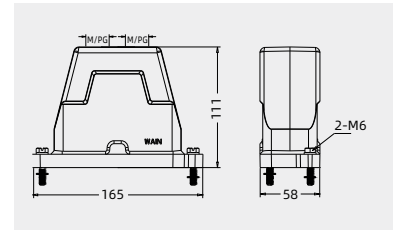

Frame, size 16B hoods/housings

for 2 pins



Describe for 2 pins	Designation	Order No.
	HF16B-002C	131 016 000 1001

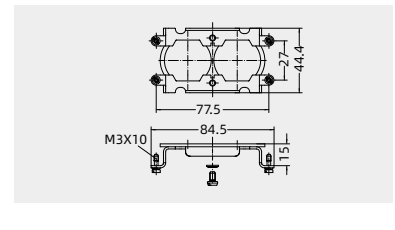

Bulkhead mounted housings



Thread	Designation	Order No.
	Screw locking	
---	HP16B/H-BK-2H	113 616 320 1001
	Toggle locking	
---	HP16B/H-BK-2T	113 616 340 1001

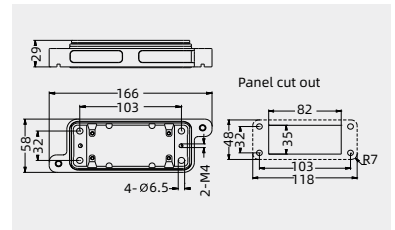

Pressure tight hoods/housings

Degree of protection: IP68/IP69K

H version

Hoods, top entry, high construction



Thread	Designation	Order No.
	Screw locking	
2M25	HP24B/H-TEH-2S-2M25	113 624 420 5023
2M32	HP24B/H-TEH-2S-2M32	113 624 420 5024
	Toggle locking	
2M25	HP24B/H-TEH-2T-2M25	113 624 440 5023
2M32	HP24B/H-TEH-2T-2M32	113 624 440 5024

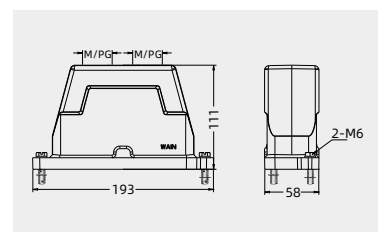

Frame, size 24B hoods/housings

for 2 pins



Describe for 2 pins	Designation	Order No.
	HF24B-002C	131 024 000 1001

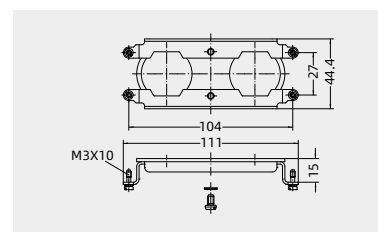

Bulkhead mounted housings



Thread	Designation	Order No.
	Screw locking	
---	HP24B/H-BK-2H	113 624 320 1001
	Toggle locking	
---	HP24B/H-BK-2T	113 624 340 1001

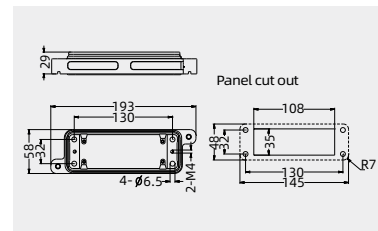

Pressure tight hoods/housings

Degree of protection: IP68/IP69K

H version

Hoods, top entry, high construction



Thread	Designation	Order No.
3M25	Screw locking	113 624 420 5036
	HP24B/H-TEH-2S-3M25	
3M25	Toggle locking	113 624 440 5036
	HP24B/H-TEH-2T-3M25	

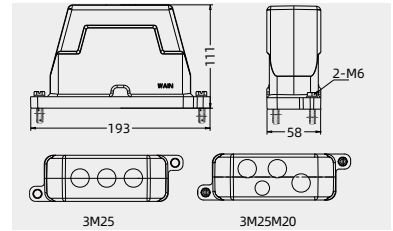

Frame, size 24B hoods/housings

for 3 pins



Describe for 3 pins	Designation	Order No.
	HF24B-003C	131 024 000 1003

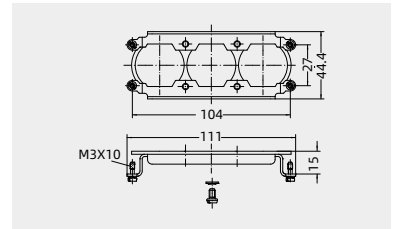

Bulkhead mounted housings



Thread	Designation	Order No.
---	Screw locking	113 624 320 1001
	HP24B/H-BK-2H	
---	Toggle locking	113 624 340 1001
	HP24B/H-BK-2T	

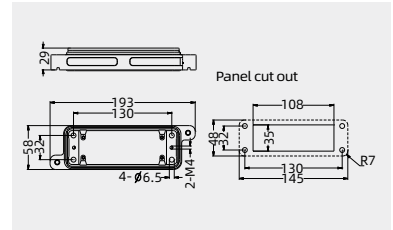

Surface mounted housings high construction



Thread	Designation	Order No.
3M25	Screw locking	113 624 220 5036
	HP24B/H-SFH-2H-3M25	
3M25	Toggle locking	113 624 240 5036
	HP24B/H-SFH-2T-3M25	

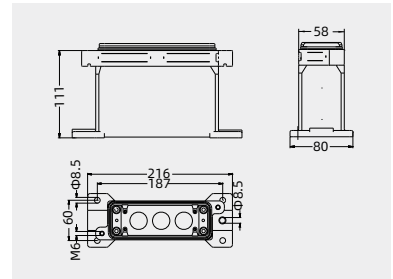

Surface mounted housings high construction



Thread	Designation	Order No.
3M25	Screw locking	113 624 920 1036
	HP24B/H-BK-SE-2H-3M25	
3M25	Toggle locking	113 624 940 1036
	HP24B/H-BK-SE-2T-3M25	

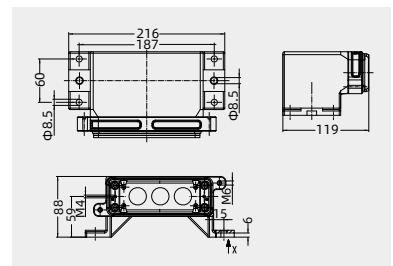

Pressure tight hoods/housings

Degree of protection: IP68/IP69K

The following hoods/housings comply with the standards for rail transport industry in China.

H version

Hoods, top entry, high construction



Thread	Designation	Order No.
	Screw locking	
M25	HP6B/H-TEH-4S-M25	113 606 430 5003
M32	HP6B/H-TEH-4S-M32	113 606 430 5004

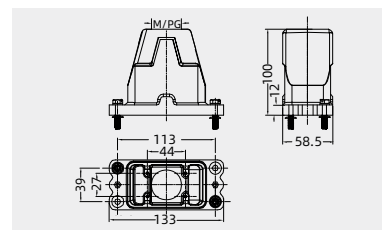

Frame, size 6B hoods/housings

for 1 pins



Describe for 1 pin	Designation	Order No.
	HF6B-001C	131 006 000 1001

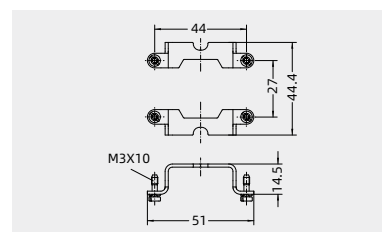

Bulkhead mounted housings



Thread	Designation	Order No.
	Screw locking	
---	HP6B/H-BK-4H	113 606 330 1001

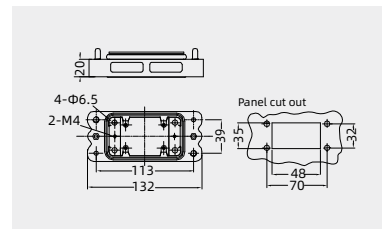

Hoods, top entry, high construction



Thread	Designation	Order No.
	Screw locking	
2M25	HP16B/H-TEH-4S-2M25	113 616 430 5023

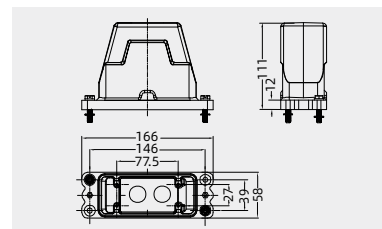

Frame, size 16B hoods/housings

for 2 pins



Describe for 2 pins	Designation	Order No.
	HF16B-002C	131 016 000 1001

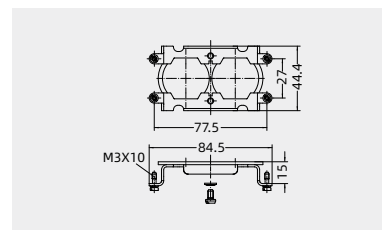

Bulkhead mounted housings



Thread	Designation	Order No.
	Screw locking	
---	HP16B/H-BK-4H	113 616 330 1001

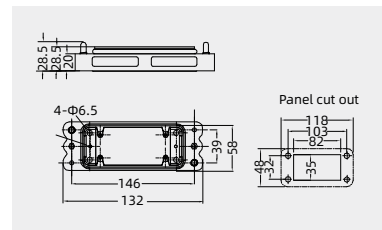

Pressure tight hoods/housings

Degree of protection: IP68/IP69K

The following hoods/housings comply with the standards for rail transport industry in China.

H version

Hoods, top entry, high construction



Thread	Designation	Order No.
	Screw locking	
2M25	HP24B/H-TEH-4S-2M25	113 624 430 5023
2M32	HP24B/H-TEH-4S-2M32	113 624 430 5024

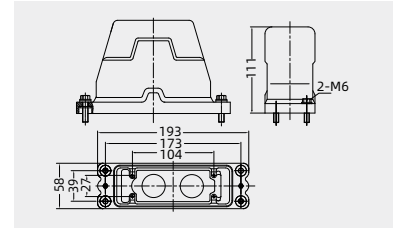

Frame, size 24B hoods/housings

for 2 pins



Describe for 2 pins	Designation	Order No.
	HF24B-002C	131 024 000 1001

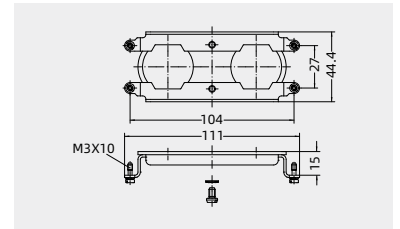

Bulkhead mounted housings



Thread	Designation	Order No.
	Screw locking	
---	HP24B/H-BK-4H	113 624 330 1001

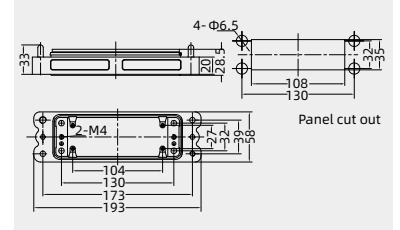

Pressure tight hoods/housings

Degree of protection: IP68/IP69K

The following hoods/housings comply with the standards for rail transport industry in China.

H version

Hoods, top entry, high construction



Thread	Designation	Order No.
3M25	HP24B/H-TEH-4S-3M25	113 624 430 5036

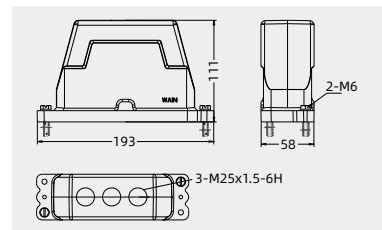

Hoods, top entry, high construction



Thread	Designation	Order No.
3M32	HP24B/H-TEHH-4S-3M32	113 624 430 5037

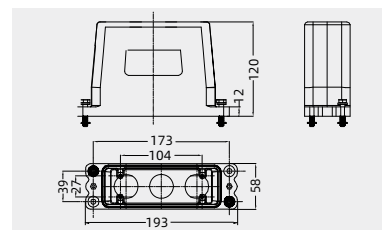

Frame, size 24B hoods/housings

for 3 pins



Describe	Designation	Order No.
for 3 pins	HF24B-003C	131 024 000 1003

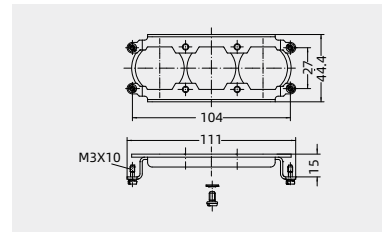

Bulkhead mounted housings



Thread	Designation	Order No.
---	HP24B/H-BK-4H	113 624 330 1001

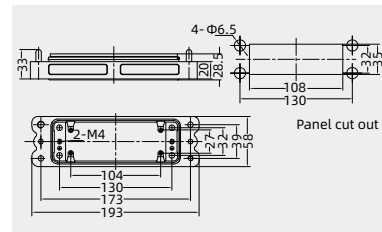

Surface mounted housings  
high construction



Thread	Designation	Order No.
3M25	HP24B/H-SFH/BK-4H-3M25	113 624 230 5036

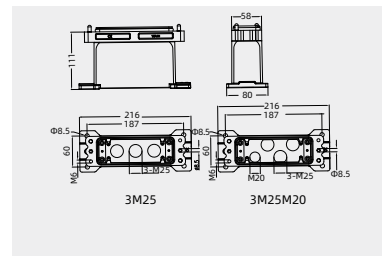

Surface mounted housings



Thread	Designation	Order No.
3M25	HP24B/H-BK-SE-4H-3M25	113 624 930 1036

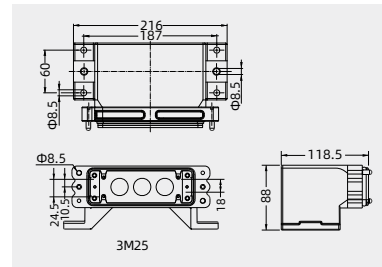

Pressure tight hoods/housings  
- enlarged

Degree of protection: IP68/IP69K

The following hoods/housings comply with the standards for rail transport industry in China.

Only suitable for cable with 18mm diameter

H version

Hoods, top entry, high construction



Thread	Designation	Order No.
	Screw locking	
3M32	HP24B/HE-TEHH-4S-3M32	113 624 430 5137

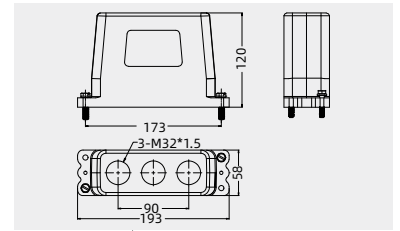

Male, Frame, size 24B hoods/housings

for 3 pins



Describe for 3 pins	Designation	Order No.
	HF24B-003C/E-M	131 024 000 1005

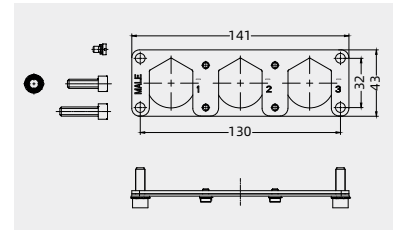

Female, Frame, size 24B hoods/housings

for 3 pins



Describe for 3 pins	Designation	Order No.
	HF24B-003C/E-F	131 024 000 1006

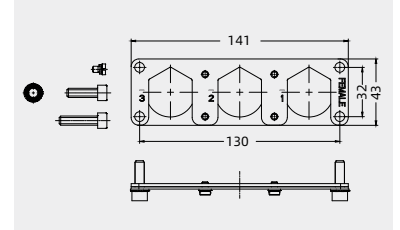

Bulkhead mounted housings



Thread	Designation	Order No.
	Screw locking	
---	HP24B/HE-BK-4H	113 624 330 1101

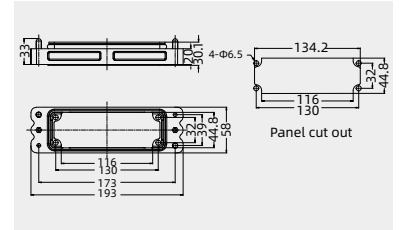

Surface mounted housings



Thread	Designation	Order No.
	Screw locking	
3M32	HP24B/HE-BK-SE-3M32	113 624 900 1137

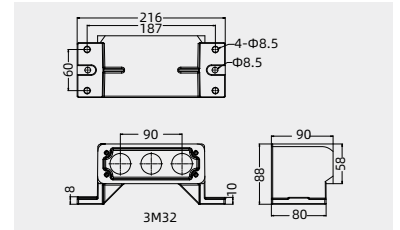



### Pressure tight hoods/housings

Degree of protection: IP68/IP69K

The following hoods/housings comply with the standards for rail transport industry in China.

Only suitable for cable with 18mm diameter

H version

#### Hoods, top entry, high construction



Thread	Designation	Order No.
	Screw locking	
4M25	HP24B/HE-TEHH-4S-4M25	113 624 430 5139

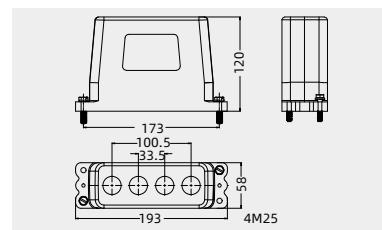

#### Male, Frame, size 24B hoods/housings

for 4 pins



Describe	Designation	Order No.
for 4 pins	HF24B-004C/E-M	131 024 000 1009

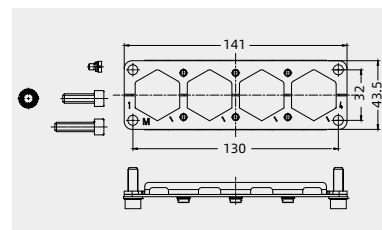

#### Female, Frame, size 24B hoods/housings

for 4 pins



Describe	Designation	Order No.
for 4 pins	HF24B-004C/E-F	131 024 000 1010

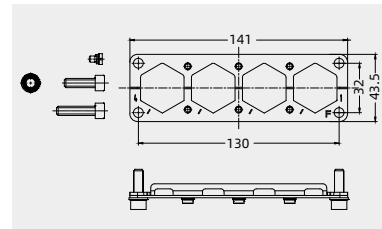

#### Bulkhead mounted housings



Thread	Designation	Order No.
	Screw locking	
---	HP24B/HE-BK-4H	113 624 330 1101

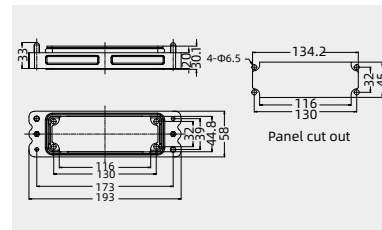

#### Surface mounted housings



Thread	Designation	Order No.
	Screw locking	
---	HP24B/HE-BK-SE-4M25	113 624 900 1139

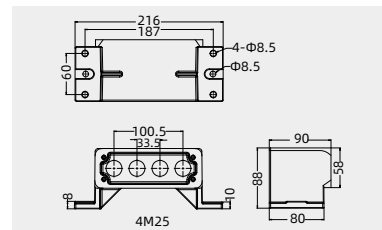

Pressure tight hoods/housings  
- enlarged

Hoods/Housings: size 48B, please find the details on page15-160 ~15-161 .

Degree of protection: IP68/IP69K

The following hoods/housings comply with the standards for rail transport industry in China.

Only suitable for cable with 18mm diameter

Frame



Insert	Designation	Order No.
Male	HF48B-004C/2HQ005-M	131 048 000 1002
Female	HF48B-004C/2HQ005-F	131 048 000 1003

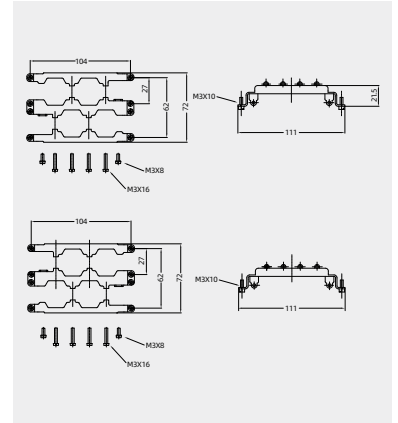

Crimp contacts 350A

350A Crimp contacts

silver plated



NO.	Male	Order No.	Female	Order No.
①	CHSM350PE-35	101 029 101 1701	CHSF350PE-35G	101 029 120 1701
②	CHSM350PE-50	101 029 101 1801	CHSF350PE-50G	101 029 120 1801

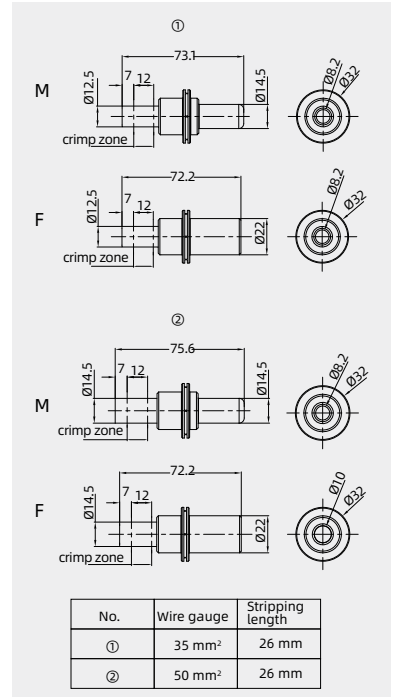

Tools

Manual hydraulic clamp



Wire gauge	Designation	Order No.
10-240mm <sup>2</sup>	TL05	198 001 001 0005

Notes: The tools for crimp terminal may influence the product quality and stability. Please select the tools recognized by our company.

# HC-650 Heavy-current inserts

## Axial screw terminal



### Technical characteristics

Specifications	DIN EN 60 664	DIN EN 61 984
Approvals		
Inserts		
Number of contacts	1,2,3	
Electrical data acc. to EN 61 984		
without adapter		
-Rated current	650A	
-Rated voltage	2000V	
-Rated impulse voltage	12kV	
-Pollution degree	3	
with adapter		
-Rated voltage	4000V	
-Rated impulse voltage	18kV	
-Pollution degree	3	
Insulation resistance	$\geq 10^{10}\Omega$	
Material	polyamide	
Limiting temperatures	-40°C ...+125°C	
Flammability acc. to UL 94	V0	
Mechanical working life(mating cycles)	$\geq 500$	
Contacts		
Material	copper alloy	
Surface	silver	
Contact resistance	$\leq 0.2m\Omega$	
For stranded wire acc. to IEC 60 228 Class 5		
Axial screw termination		
- Wire gauge	35-70 /70-120 / 150-185mm <sup>2</sup>	
- MCM	138 - 236 / 300 - 350	
- Stripping length	23-25	
- Max. cable diameter	26.5mm	
	mm <sup>2</sup> 35 50 70 95 120 150 185	
- Tightening torque	Nm 8 10 12 14 16 17 18	
Screw terminal		
- Thread	M12	
- Tightening torque	8-18Nm	
Frame		
Material	stainless steel	
Tightening torque of the M3 fixing screws	0.5Nm	

### Current carrying capacity

The current carrying is limited by maximum temperature of materials for inserts and contacts including terminals

Control and test procedures according to DIN EN 60512-5

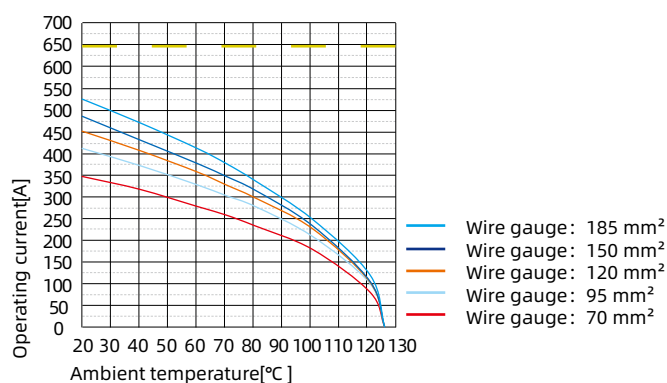

24B Pressure tight hoods/housings with 2 modules

# HC-650 Heavy-current inserts

4000V 650A

## Inserts

Hoods/Housings: size Pressure tight hoods/housings, please find the details on page 12-24~12-26.

### Axial screw terminal<sup>1)</sup>



Insert	Wire gauge	Designation	Order No.
Male	35-70mm <sup>2</sup>	HC650.70-M(35-70mm <sup>2</sup> )	131 001 011 0203
	70-120mm <sup>2</sup>	HC650.120-M (70-120mm <sup>2</sup> )	131 001 011 0201
	150-185mm <sup>2</sup>	HC650.185-M (150-185mm <sup>2</sup> )	131 001 011 0202
Female	35-70mm <sup>2</sup>	HC650.70-F(35-70mm <sup>2</sup> )	131 001 021 0203
	70-120mm <sup>2</sup>	HC650.120-F (70-120mm <sup>2</sup> )	131 001 021 0201
	150-185mm <sup>2</sup>	HC650.185-F (150-185mm <sup>2</sup> )	131 001 021 0202

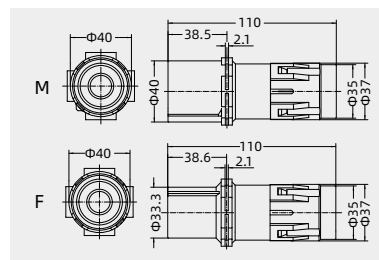

### Assembly details

**Step 1:** Strip cable to 23+2 mm

**Step 2:** Push conductor through the cable gland and the housing. Push the stripped end of the conductor into the termination entry of the module until the insulation touches the contact.

**Step 3:** To tighten the axial screw, a hexagonal wrench size 8 is needed. Insert the hexagonal wrench on the mating side of the contact. At the same time, push the conductor over the axial screw. The locking screw has to be tightened with the recommended tightening torque that is determined by the conductor's cross section.

**Step 4:** Once the modules are terminated, they are mounted into the housing by using two metal frames (tightening torque of the fixing screws = 0.5 Nm). The modules have 4 pegs formed by 2 parallel ribs (each peg shapes like a "H"). Each rib takes 1 pole frame, where the lateral link has to go into the relief of the frame. The 2 pole frames have 2 cutouts on the wall which get fitted to the "H"-shaped pegs (see figure). The heads of the screws have to face the mating direction of the module. Coding can be established by rotating the contact by 90 degrees. Therefore it is important that the corresponding modules are assembled in the correct position otherwise mating is not possible.

**Step 5:** After assembling the modules in the housing, the tightening torque of the locking screw can be checked and corrected if necessary.

**Step 6:** After final assembly of the contacts, the user should ensure that the cable is adequately strain relieved to protect the contact from radial stress.

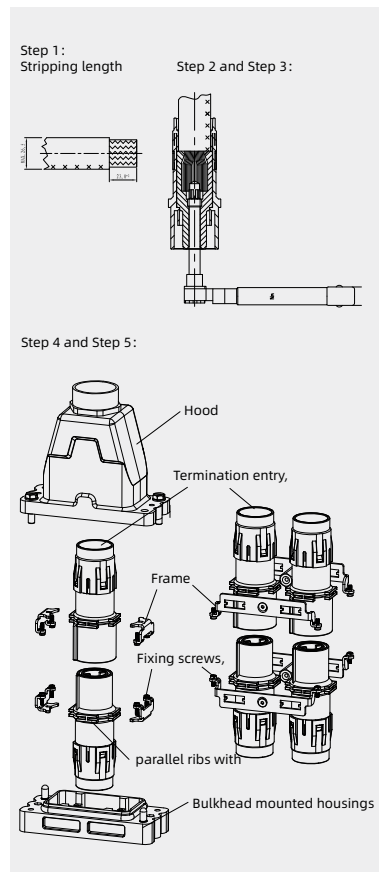

1) See P00-30-00-31 for the structural characteristics and description of Axial screw terminal.

# HC-650 Heavy-current inserts

## Crimp terminal



### Technical characteristics

Specifications	DIN EN 60 664	DIN EN 61 984
Approvals		
Inserts		
Number of contacts	1,2,3	
Electrical data acc. to EN 61 984		
without adapter		
-Rated current	650A	
-Rated voltage	2000V	
-Rated impulse voltage	12kV	
-Pollution degree	3	
with adapter		
-Rated voltage	4000V	
-Rated impulse voltage	18kV	
-Pollution degree	3	
Insulation resistance	$\geq 10^{10}\Omega$	
Material	polyamide	
Limiting temperatures	-40°C ...+125°C	
Flammability acc. to UL 94	V0	
Mechanical working life(mating cycles)	$\geq 500$	
Contacts		
Material	copper alloy	
Surface	hard-silver plated	
Contact resistance	$\leq 0.3m\Omega$	
Crimp terminal		
- mm <sup>2</sup>	240mm <sup>2</sup>	
Max. insulation diameter	32mm	
Pressing force requirement	130kN	
Frame		
Material	stainless steel	
Tightening torque of the M3 fixing screws	0.5 Nm	
Tightening torque of the M4 fixing screws	1.5 Nm	
Tightening torque of the M6 fixing screws	4 Nm	

### Current carrying capacity

The current carrying is limited by maximum temperature of materials for inserts and contacts including terminals

Control and test procedures according to DIN EN 60512-5

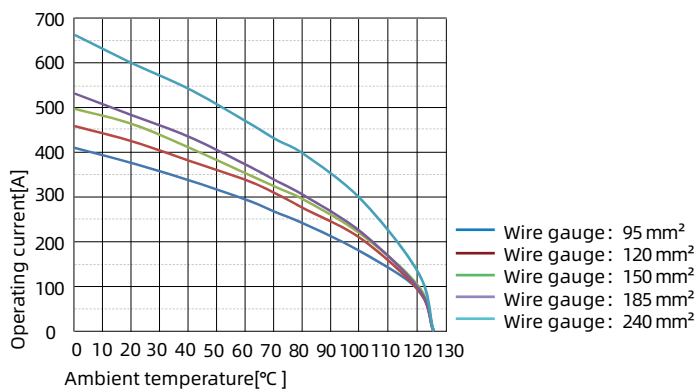

24B Pressure tight hoods/housings with 2 modules

### Assembly Details

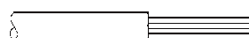

Cut the cable head square and strip the insulation

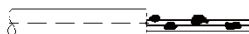

The copper strands must be cleaned from dirt and oxide film



Copper strands must not be twisted



Check if the cable strand is inserted completely into the crimp ferrule of the contact

# HC-650 Heavy-current inserts

4000V 650A

## Inserts

Hoods/Housings: size Pressure tight hoods/housings, please find the details on page 12-24-12-26.

### Crimp terminal

Order crimp contacts separately



Insert	Designation	Order No.
Male	HC650-MC	131 001 010 0201
Female	HC650-FC	131 001 020 0201

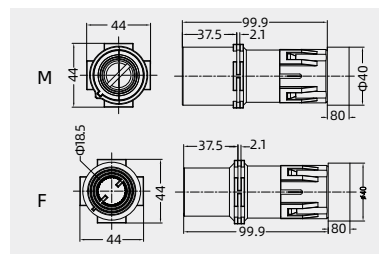

## Crimp contacts 650A (with crown spring), for HC650 inserts.

Contact resistance  $\leq 0.3m\Omega$

silver plated



NO.	Male	Order No.	Female	Order No.
①	CHSM650-95	101 030 110 2002	CHSF650-95G	101 030 120 2002
①	CHSM650-120	101 030 110 2101	CHSF650-120G	101 030 120 2101
①	CHSM650-150	101 030 110 2202	CHSF650-150G	101 030 120 2202
②	CHSM650-185	101 030 110 2301	CHSF650-185G	101 030 120 2303
②	CHSM650-240	101 030 110 2401	CHSF650-240G	101 030 120 2403

For stranded wire acc. to IEC 60 228-5  
Crimp zone acc. to DIN 46 235

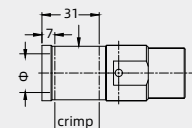
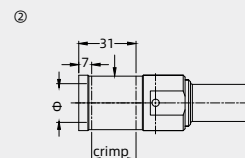
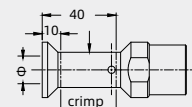
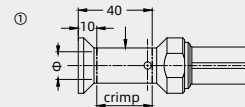

### Tools

Manual hydraulic clamp



Wire gauge	Designation	Order No.
10-240mm <sup>2</sup>	TL05	198 001 001 0005

NO.	Wire gauge	Φ	Stripping length
①	95 mm <sup>2</sup>	13.5 mm	42 mm
	120 mm <sup>2</sup>	15.5 mm	42 mm
	150 mm <sup>2</sup>	17 mm	42 mm
②	185 mm <sup>2</sup>	19.4 mm	46 mm
	240 mm <sup>2</sup>	22.5 mm	46 mm

Notes: The tools for crimp terminal may influence the product quality and stability. Please select the tools recognized by our company.

Pressure tight hoods/housings

Degree of protection: IP68/IP69K

H version

Hoods, top entry, high construction



Thread	Designation	Order No.
	Screw locking	
M40	HP6B/H-TEH-2S-M40B	113 606 420 5105
	Toggle locking	
M40	HP6B/H-TEH-2T-M40B	113 606 440 5105

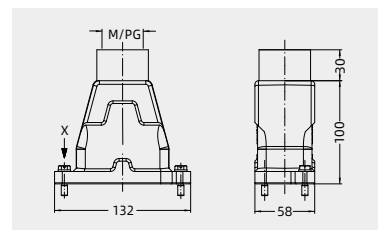

Frame, size 6B hoods/housings

for 1 pins



Describe for 1 pin	Designation	Order No.
	HF6B-001R	131 006 000 1002

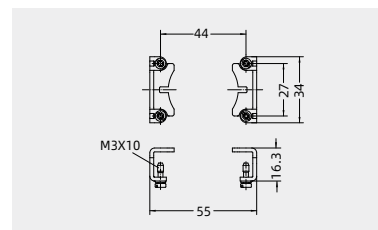

Bulkhead mounted housings



Thread	Designation	Order No.
	Screw locking	
---	HP6B/H-BKH-2H	113 606 320 1002
	Toggle locking	
---	HP6B/H-BKH-2T	113 606 340 1002

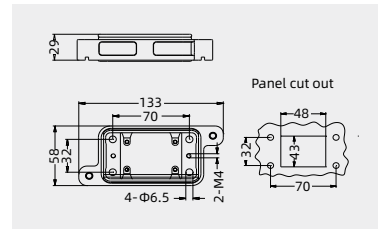

Hoods, top entry, high construction



Thread	Designation	Order No.
	Screw locking	
2M40	HP24B/H-TEH-2S-2M40B	113 624 420 5125
	Toggle locking	
2M40	HP24B/H-TEH-2T-2M40B	113 624 440 5125

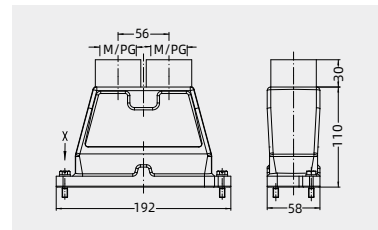

Frame, size 24B hoods/housings

for 2 pins



Describe for 2 pins	Designation	Order No.
	HF24B-002R	131 024 000 1002

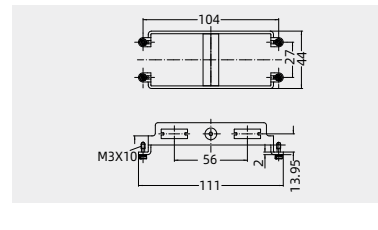

Bulkhead mounted housings



Thread	Designation	Order No.
	Screw locking	
---	HP24B/H-BK-2H	113 624 320 1001
	Toggle locking	
---	HP24B/H-BK-2T	113 624 340 1001

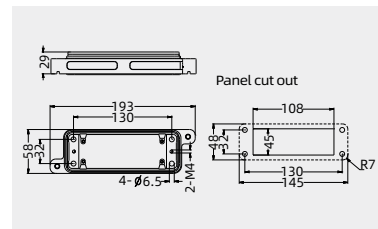

HC

Pressure tight hoods/housings

Degree of protection: IP68/IP69K

The following hoods/housings comply with the standards for rail transport industry in China.

H version

Hoods, top entry, high construction



Thread	Designation	Order No.
M40	HP6B/H-TEH-4S-M40B	113 606 430 5105

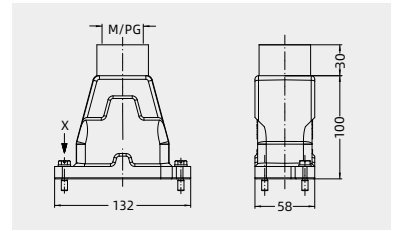

Frame, size 6B hoods/housings

for 1 pins



Describe for 1 pin	Designation	Order No.
	HF6B-001R	131 006 000 1002

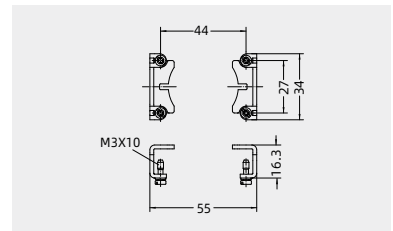

Bulkhead mounted housings



Thread	Designation	Order No.
---	HP6B/H-BK-4H	113 606 330 1001

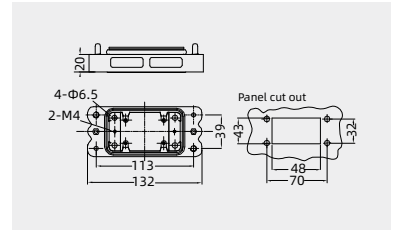

Hoods, top entry, high construction



Thread	Designation	Order No.
2M40	HP24B/H-TEH-4S-2M40B	113 624 430 5125

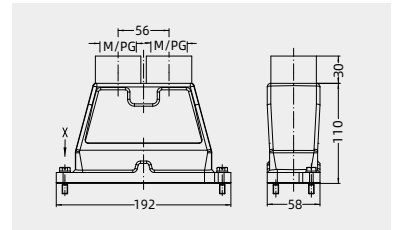

Frame, size 24B hoods/housings

for 2 pins



Describe for 2 pins	Designation	Order No.
	HF24B-002R	131 024 000 1002

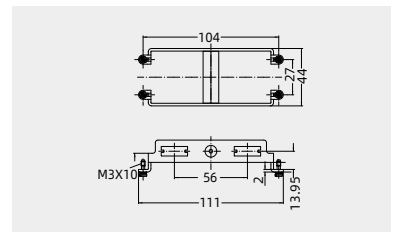

Bulkhead mounted housings



Thread	Designation	Order No.
---	HP24B/H-BK-4H	113 624 330 1001

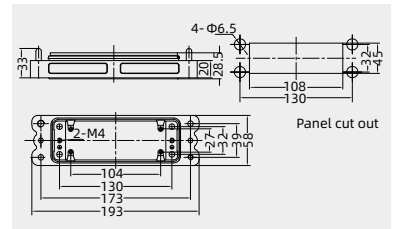



Pressure tight hoods/housings  
- enlarged

Degree of protection: IP68/IP69K

The following hoods/housings comply with the standards for rail transport industry in China.

Only suitable for cable with 25mm diameter

H version

Hoods, top entry, high construction



Thread	Designation	Order No.
	Screw locking	
3M32	HP24B/HE-TEHH-4S-3M32	113 624 430 5137

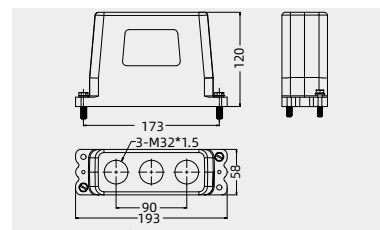

Male, Frame, size 24B hoods/housings

for 3 pins



Describe	Designation	Order No.
for 3 pins	HF24B-003R/E-M	131 024 000 1007

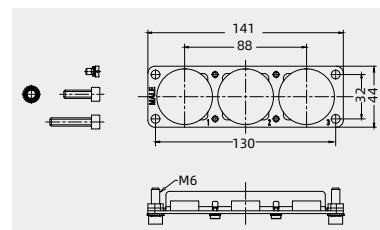

Female, Frame, size 24B hoods/housings

for 3 pins



Describe	Designation	Order No.
for 3 pins	HF24B-003R/E-F	131 024 000 1008

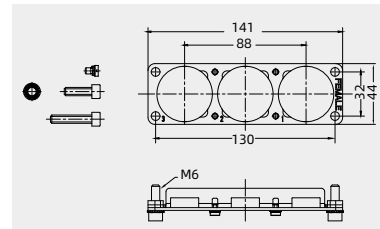

Bulkhead mounted housings



Thread	Designation	Order No.
	Screw locking	
---	HP24B/HE-BK-4H	113 624 330 1101

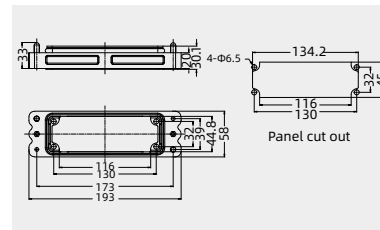

Surface mounted housings



Thread	Designation	Order No.
	Screw locking	
3M32	HP24B/HE-BK-SE-3M32	113 624 900 1137

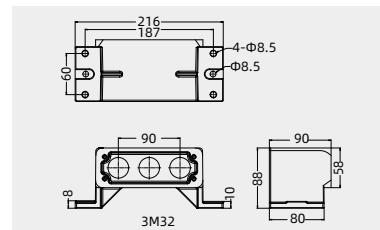

Hexagonal adapter [optional]

metal version  
with O-Ring



Describe	Designation	Order No.
for 650 Hoods/Housings:	WNSC-M32M32/APT	102 103 019 1001
	HP24B/HE-TEHH-4S-3M32,	
	HP24B/HE-BK-SE-3M32	

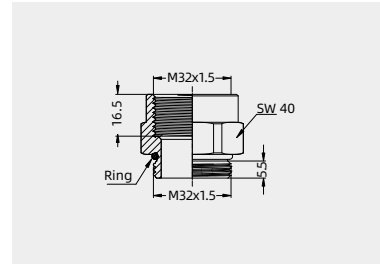

## Pressure tight hoods/housings

Degree of protection: IP68/IP69K

The following hoods/housings comply with the standards for rail transport industry in China.

H version

### Hoods, top entry, high construction



Thread	Designation	Order No.
M50	Screw locking	114 000 435 0001
	HP1T/H-TEH-4S-M50	

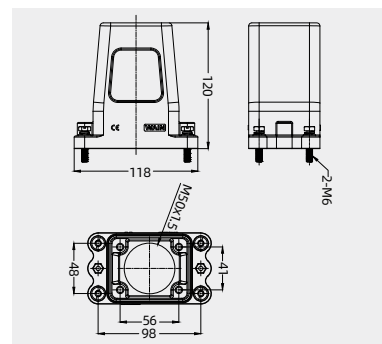

### Bulkhead mounted housings



Thread	Designation	Order No.
---	Screw locking	114 000 335 0001
	HP1T/H-BK-4H	

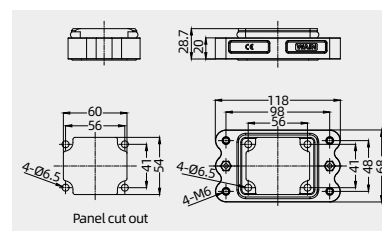

### Protective cover (housings)



Thread	Designation	Order No.
---	Screw locking	114 000 135 9011
	HP1T/H-MCV-4S	

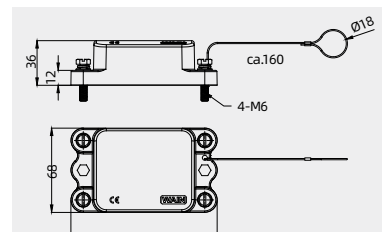

### Protective cover (Hoods)



Thread	Designation	Order No.
---	Screw locking	114 000 135 9001
	HP1T/H-MCV-4H	

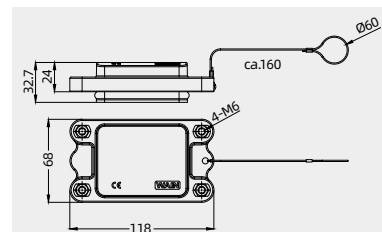

### Frame



Describe for 1 pins	Designation	Order No.
	HF1T-001	131 001 099 0001

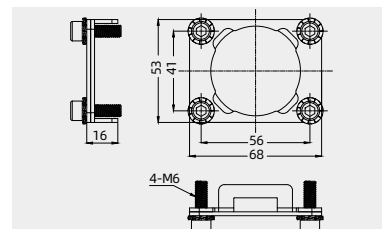

### Coding element



Describe coding, pokayoke	Designation	Order No.
	CODE-HP	198 002 005 0038

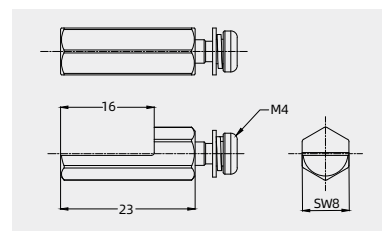

# HC-1000 Heavy-current inserts

4000V 1000A

## Inserts

Crimp terminal

Order crimp contacts separately



Insert	Designation	Order No.
Male	HC1000-MC	131 001 010 0506
Female	HC1000-FC	131 001 020 0506

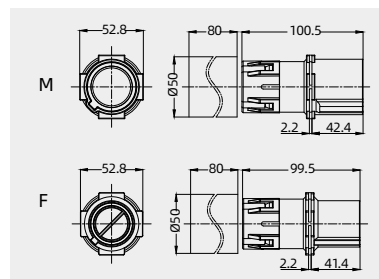

## Crimp contacts 1000A

Crimp contacts 1000A

silver plated



NO.	Male	Order No.	Female	Order No.
①	CHSM1000-240	101 042 110 2401	CHSF1000-240G	101 042 120 2401
②	CHSM1000-300	101 042 110 3551	CHSF1000-300G	101 042 120 3551

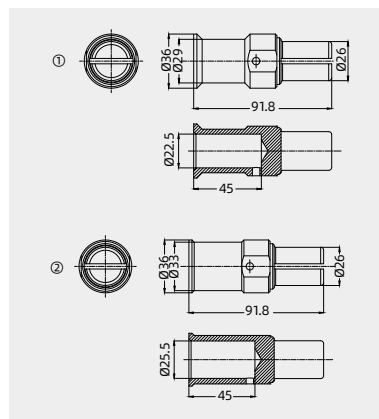

Tools

Manual hydraulic clamp



Wire gauge	Designation	Order No.
10-300mm <sup>2</sup>	TL05-EA	198 001 001 0020

# HCM Series



## HCM small-sized solder insert

### Technical characteristics

Specifications	DIN EN 60 664 DIN EN 61 984
Approvals	
Inserts	
Electrical data acc. to EN 61 984	
Number of contacts	15、 18、 21
Rated current	5A
Rated voltage	50V
Rated impulse voltage	0.8KV
Pollution degree	3
Insulation resistance	$\geq 10^{10}\Omega$
Material	polycarbonate/thermoplastic resin
Limiting temperatures	-40°C - +85°C
Mechanical working life(mating cycles)	$\geq 50$
Contacts	
Material	copper alloy
Contact resistance	$\leq 3m\Omega$
Crimp terminal	
-mm <sup>2</sup>	0.09-0.82mm <sup>2</sup>
-AWG	28-18
Surface	hard-silver plated
	hard-gold plated
Solder terminal	Solder hole 0.8mm

# HCM-015 small-sized solder insert

50V 5A

## Inserts

Solder/Crimp terminal

Order crimp contacts separately



Insert	Color	Designation	Order No.
Male	Black	HCM-015-MT.BK	137 015 001 0002
	White	HCM-015-MT.WH	137 015 001 0003
	Grey	HCM-015-MT.GY	137 015 001 0004
Female	Blue	HCM-015-MT.BU	137 015 001 0005
	Black	HCM-015-FC.BK	137 015 020 0002
	White	HCM-015-FC.WH	137 015 020 0003
	Grey	HCM-015-FC.GY	137 015 020 0004
	Blue	HCM-015-FC.BU	137 015 020 0005

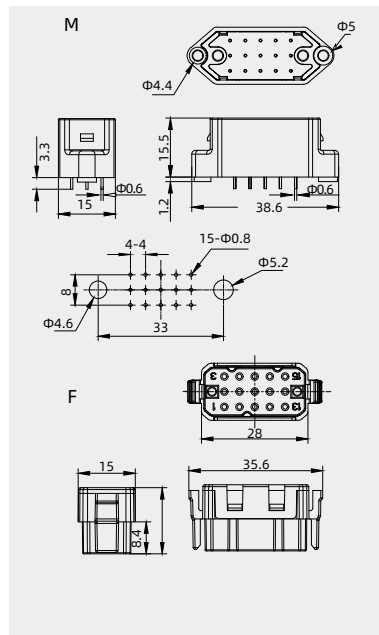

Coding element



Description	Designation	Order No.
coding, pokayoke	CODE-Q3	198 002 005 0034

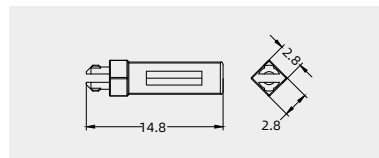

## Crimp contacts

Crimp contacts 5A

Contact resistance  $\leq 3m\Omega$   
silver plated



gold plated



Female	Order No.
CSSF-0.25	101 014 120 0101
CSSF-0.33	101 014 120 0201
CSSF-0.52	101 014 120 0501
CSSF-0.82	101 014 120 0701
<hr/>	
CSGF-0.25	101 014 220 0101
CSGF-0.33	101 014 220 0201
CSGF-0.52	101 014 220 0501
CSGF-0.82	101 014 220 0701

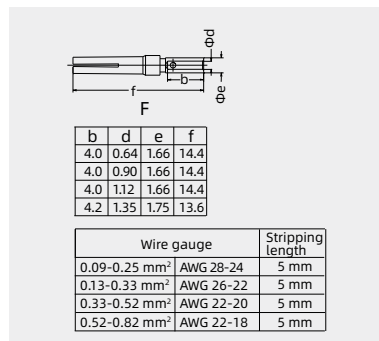

# HCM-015 small-sized solder insert

## Stamped contacts 5A

Contact resistance  $\leq 10m\Omega$

silver plated



gold plated



coil stock



Note: 10kpcs/volume

### Tools

Crimping tool



Contact removal tool



Male	Order No.	Female	Order No.
CSSM-0.82P	101 014 110 0750	CSSF-0.82P	101 014 120 0750
CSGM-0.82P	101 014 210 0750	CSGF-0.82P	101 014 220 0750

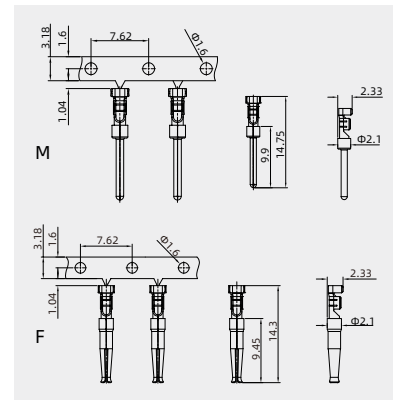

Wire gauge	Designation	Order No.
0.09-0.82mm <sup>2</sup>	TL03	198 001 001 0002
Application	Designation	Order No.
for 5A crimp contact	TL08	198 001 000 0006

Notes: The tools for crimp terminal may influence the product quality and stability. Please select the tools recognized by our company.

# HCM-018 small-sized solder insert

50V 5A

## Inserts

Solder/Crimp terminal  
Order crimp contacts separately



Insert	Color	Designation	Order No.
Male	Black	HCM-018-MT.BK	137 018 001 0002
	White	HCM-018-MT.WH	137 018 001 0003
	Grey	HCM-018-MT.GY	137 018 001 0004
Female	Black	HCM-018-FC.BK	137 018 020 0002
	White	HCM-018-FC.WH	137 018 020 0003
	Grey	HCM-018-FC.GY	137 018 020 0004
	Blue	HCM-018-FC.BU	137 018 020 0005

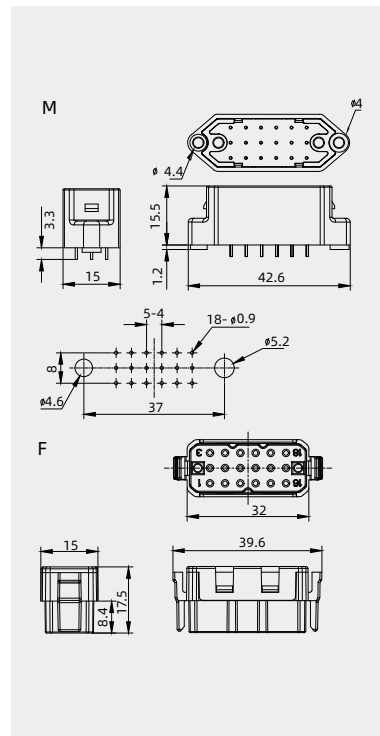

## Coding element



Description	Designation	Order No.
coding, pokayoke	CODE-Q3	198 002 005 0034

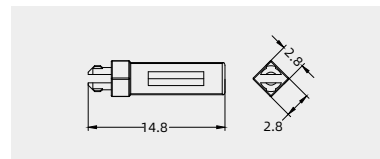

## Crimp contacts

Crimp contacts 5A

Contact resistance  $\leq 3m\Omega$   
silver plated



gold plated



Female	Order No.
CSSF-0.25	101 014 120 0101
CSSF-0.33	101 014 120 0201
CSSF-0.52	101 014 120 0501
CSSF-0.82	101 014 120 0701
CSGF-0.25	101 014 220 0101
CSGF-0.33	101 014 220 0201
CSGF-0.52	101 014 220 0501
CSGF-0.82	101 014 220 0701

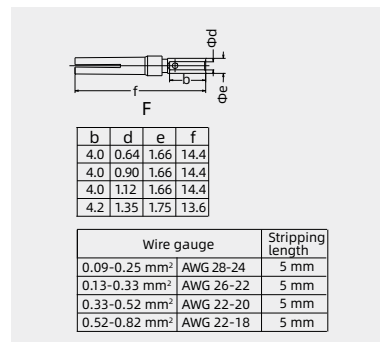



# HCM-018 small-sized solder insert

## Stamped contacts 5A

Contact resistance  $\leq 10\text{m}\Omega$

silver plated



gold plated



coil stock



Note: 10kpcs/volume

### Tools

Crimping tool



Contact removal tool



Male	Order No.	Female	Order No.
CSSM-0.82P	101 014 110 0750	CSSF-0.82P	101 014 120 0750
CSGM-0.82P	101 014 210 0750	CSGF-0.82P	101 014 220 0750

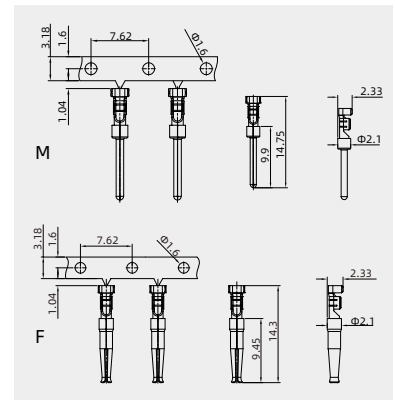

Wire gauge	Designation	Order No.
0.09-0.82mm <sup>2</sup>	TL03	198 001 001 0002
Application	Designation	Order No.
for 5A crimp contact	TL08	198 001 000 0006

Notes: The tools for crimp terminal may influence the product quality and stability. Please select the tools recognized by our company.

# HCM-021 small-sized solder insert

50V 5A

## Inserts

Solder/Crimp terminal

Order crimp contacts separately



Insert	Color	Designation	Order No.
Male	Black	HCM-021-MT.BK	137 021 001 0002
	White	HCM-021-MT.WH	137 021 001 0003
	Grey	HCM-021-MT.GY	137 021 001 0004
	Blue	HCM-021-MT.BU	137 021 001 0005
	Red	HCM-021-MT.RD	137 021 001 0006
	Yellow	HCM-021-MT.YE	137 021 001 0007
Female	Black	HCM-021-FC.BK	137 021 020 0002
	White	HCM-021-FC.WH	137 021 020 0003
	Grey	HCM-021-FC.GY	137 021 020 0004
	Blue	HCM-021-FC.BU	137 021 020 0005
	Red	HCM-021-FC.RD	137 021 020 0006
	Yellow	HCM-021-FC.YE	137 021 020 0007
	Green	HCM-021-FC.GN	137 021 020 0008

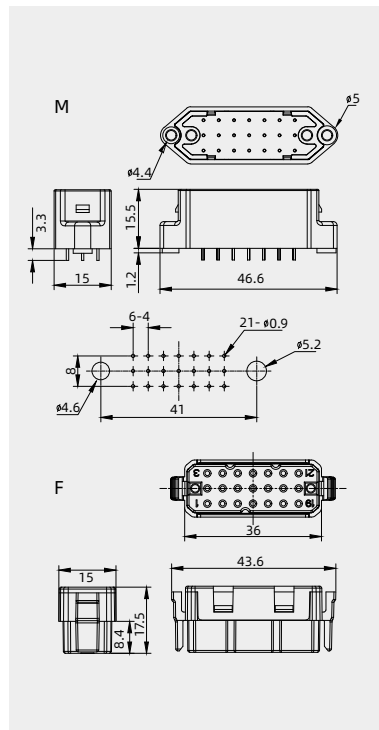

Coding element



Description	Designation	Order No.
coding, pokayoke	CODE-Q3	198 002 005 0034

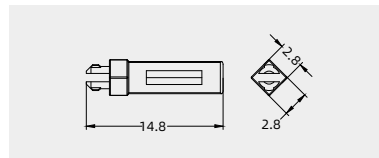

## Crimp contacts

Crimp contacts 5A

Contact resistance  $\leq 3\text{m}\Omega$   
silver plated



gold plated



Female	Order No.
CSSF-0.25	101 014 120 0101
CSSF-0.33	101 014 120 0201
CSSF-0.52	101 014 120 0501
CSSF-0.82	101 014 120 0701
CSGF-0.25	101 014 220 0101
CSGF-0.33	101 014 220 0201
CSGF-0.52	101 014 220 0501
CSGF-0.82	101 014 220 0701

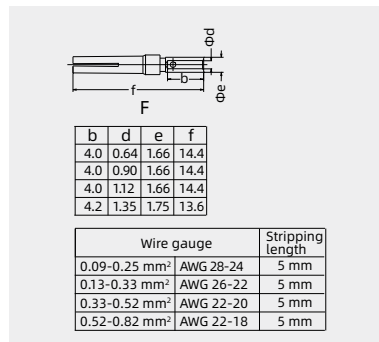

# HCM-021 small-sized solder insert

## Stamped contacts 5A

Contact resistance  $\leq 10\text{m}\Omega$

silver plated



gold plated



coil stock



Note: 10kpcs/volume

### Tools

Crimping tool



Contact removal tool



Male	Order No.	Female	Order No.
CSSM-0.82P	101 014 110 0750	CSSF-0.82P	101 014 120 0750
CSGM-0.82P	101 014 210 0750	CSGF-0.82P	101 014 220 0750

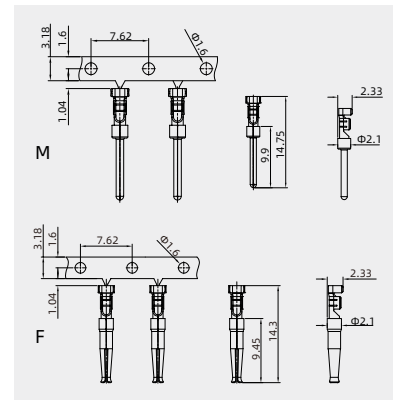

Wire gauge	Designation	Order No.
0.09-0.82mm <sup>2</sup>	TL03	198 001 001 0002
Application	Designation	Order No.
for 5A crimp contact	TL08	198 001 000 0006

Notes: The tools for crimp terminal may influence the product quality and stability. Please select the tools recognized by our company.

# Crimp contacts



## Crimp contacts

### Crimp contacts 5A-Standard, for HM, EMC-008, D-SUB, HR23 inserts.

Contact resistance  $\leq 3m\Omega$

silver plated



gold plated



Male	Order No.	Female	Order No.
CSSM-0.25	101 014 110 0101	CSSF-0.25	101 014 120 0101
CSSM-0.33	101 014 110 0201	CSSF-0.33	101 014 120 0201
CSSM-0.52	101 014 110 0501	CSSF-0.52	101 014 120 0501
CSSM-0.82	101 014 110 0701	CSSF-0.82	101 014 120 0701
CSGM-0.25	101 014 210 0101	CSGF-0.25	101 014 220 0101
CSGM-0.33	101 014 210 0201	CSGF-0.33	101 014 220 0201
CSGM-0.52	101 014 210 0501	CSGF-0.52	101 014 220 0501
CSGM-0.82	101 014 210 0701	CSGF-0.82	101 014 220 0701

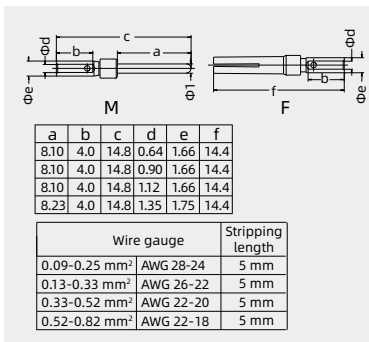

### Stamped contacts 5A

Contact resistance  $\leq 10m\Omega$

silver plated



gold plated



coil stock



Wire gauge	Contacts	Female	Order No.
0.09-0.82mm <sup>2</sup>	male	CSSM-0.82P	101 014 110 0750
	female	CSSF-0.82P	101 014 120 0750
0.09-0.82mm <sup>2</sup>	male	CSGM-0.82P	101 014 210 0750
	female	CSGF-0.82P	101 014 220 0750

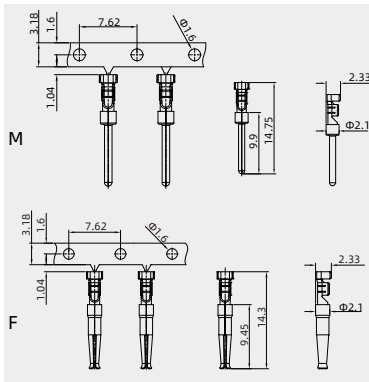

### Crimp contacts 10A-Standard, for HD, HDD, HM, HK, HQ inserts.

Contact resistance  $\leq 3m\Omega$

silver plated



gold plated



Male	Order No.	Female	Order No.
CDSM-0.25	101 017 110 0101	CDSF-0.25	101 017 120 0101
CDSM-0.37	101 017 110 0301	CDSF-0.37	101 017 120 0301
CDSM-0.50	101 017 110 0401	CDSF-0.50	101 017 120 0401
CDSM-0.75	101 017 110 0601	CDSF-0.75	101 017 120 0601
CDSM-1.0	101 017 110 0801	CDSF-1.0	101 017 120 0801
CDSM-1.5	101 017 110 0901	CDSF-1.5	101 017 120 0901
CDSM-2.5	101 017 110 1001	CDSF-2.5	101 017 120 1001
CDGM-0.25	101 017 210 0101	CDGF-0.25	101 017 220 0101
CDGM-0.37	101 017 210 0301	CDGF-0.37	101 017 220 0301
CDGM-0.50	101 017 210 0401	CDGF-0.50	101 017 220 0401
CDGM-0.75	101 017 210 0601	CDGF-0.75	101 017 220 0601
CDGM-1.0	101 017 210 0801	CDGF-1.0	101 017 220 0801
CDGM-1.5	101 017 210 0901	CDGF-1.5	101 017 220 0901
CDGM-2.5	101 017 210 1001	CDGF-2.5	101 017 220 1001

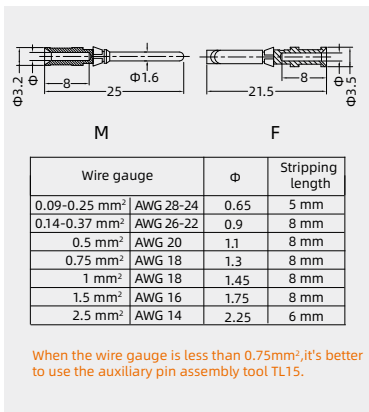

### Crimp contacts 10A-Enhanced I ( prevent deflected insertion), HD, HDD, HM, HK, HQ inserts.

Contact resistance  $\leq 3m\Omega$

silver plated



gold plated



Male	Order No.	Female	Order No.
CDSM-0.37	101 017 110 0301	CDSF-0.37C	101 017 120 0306
CDSM-0.50	101 017 110 0401	CDSF-0.50C	101 017 120 0406
CDSM-0.75	101 017 110 0601	CDSF-0.75C	101 017 120 0606
CDSM-1.0	101 017 110 0801	CDSF-1.0C	101 017 120 0806
CDSM-1.5	101 017 110 0901	CDSF-1.5C	101 017 120 0906
CDSM-2.5	101 017 110 1001	CDSF-2.5C	101 017 120 1006
CDGM-0.37	101 017 210 0301	CDGF-0.37C	101 017 220 0306
CDGM-0.50	101 017 210 0401	CDGF-0.50C	101 017 220 0406
CDGM-0.75	101 017 210 0601	CDGF-0.75C	101 017 220 0606
CDGM-1.0	101 017 210 0801	CDGF-1.0C	101 017 220 0806
CDGM-1.5	101 017 210 0901	CDGF-1.5C	101 017 220 0906
CDGM-2.5	101 017 210 1001	CDGF-2.5C	101 017 220 1006

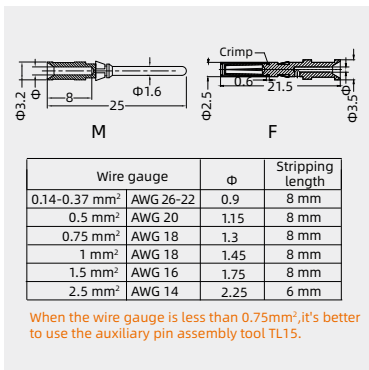

Notes: The tools for crimp terminal may influence the product quality and stability. Please select the tools recognized by our company.

## Crimp contacts

Crimp contacts 10A-Enhanced II ( prevent deflected insertion,vibration resistance), for HD, HDD, HM, HK, HQ inserts.

Contact resistance  $\leq 3m\Omega$ 

silver plated



gold plated



Male	Order No.	Female	Order No.
CDSM-0.37B	101 017 110 0303	CDSF-0.37B	101 017 120 0303
CDSM-0.50B	101 017 110 0403	CDSF-0.50B	101 017 120 0403
CDSM-0.75B	101 017 110 0603	CDSF-0.75B	101 017 120 0603
CDSM-1.0B	101 017 110 0803	CDSF-1.0B	101 017 120 0803
CDSM-1.5B	101 017 110 0903	CDSF-1.5B	101 017 120 0903
CDSM-2.5B	101 017 110 1003	CDSF-2.5B	101 017 120 1003
CDGM-0.37B	101 017 210 0303	CDGF-0.37B	101 017 220 0303
CDGM-0.50B	101 017 210 0403	CDGF-0.50B	101 017 220 0403
CDGM-0.75B	101 017 210 0603	CDGF-0.75B	101 017 220 0603
CDGM-1.0B	101 017 210 0803	CDGF-1.0B	101 017 220 0803
CDGM-1.5B	101 017 210 0903	CDGF-1.5B	101 017 220 0903
CDGM-2.5B	101 017 210 1003	CDGF-2.5B	101 017 220 1003

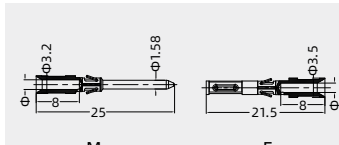

Wire gauge	$\phi$	Stripping length
0.14-0.37 mm <sup>2</sup> AWG 26-22	0.9	8 mm
0.5 mm <sup>2</sup> AWG 20	1.15	8 mm
0.75 mm <sup>2</sup> AWG 18	1.3	8 mm
1 mm <sup>2</sup> AWG 18	1.45	8 mm
1.5 mm <sup>2</sup> AWG 16	1.75	8 mm
2.5 mm <sup>2</sup> AWG 14	2.25	6 mm

When the wire gauge is less than 0.75mm<sup>2</sup>, it's better to use the auxiliary pin assembly tool TL15.

Crimp contacts 10A-Enhanced III (recommended use in rail transport industry), for HD, HDD, HM, HK, HQ inserts.

Contact resistance  $\leq 3m\Omega$ 

silver plated



gold plated



Male	Order No.	Female	Order No.
ZCDSM-0.37	101 017 110 0302	ZCDSF-0.37	101 017 120 0302
ZCDSM-0.50	101 017 110 0402	ZCDSF-0.50	101 017 120 0402
ZCDSM-0.75	101 017 110 0602	ZCDSF-0.75	101 017 120 0602
ZCDSM-1.0	101 017 110 0802	ZCDSF-1.0	101 017 120 0802
ZCDSM-1.5	101 017 110 0902	ZCDSF-1.5	101 017 120 0902
ZCDSM-2.5	101 017 110 1002	ZCDSF-2.5	101 017 120 1002
ZCDGM-0.37	101 017 210 0302	ZCDGF-0.37	101 017 220 0302
ZCDGM-0.50	101 017 210 0402	ZCDGF-0.50	101 017 220 0402
ZCDGM-0.75	101 017 210 0602	ZCDGF-0.75	101 017 220 0602
ZCDGM-1.0	101 017 210 0802	ZCDGF-1.0	101 017 220 0802
ZCDGM-1.5	101 017 210 0902	ZCDGF-1.5	101 017 220 0902
ZCDGM-2.5	101 017 210 1002	ZCDGF-2.5	101 017 220 1002

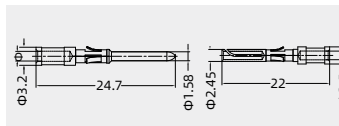

Wire gauge	$\phi$	Stripping length
0.14-0.37 mm <sup>2</sup> AWG 26-22	0.9	6 mm
0.5 mm <sup>2</sup> AWG 20	1.1	6 mm
0.75 mm <sup>2</sup> AWG 18	1.3	6 mm
1 mm <sup>2</sup> AWG 18	1.45	6 mm
1.5 mm <sup>2</sup> AWG 16	1.75	6 mm
2.5 mm <sup>2</sup> AWG 14	2.25	6 mm

When the wire gauge is less than 0.75mm<sup>2</sup>, it's better to use the auxiliary pin assembly tool TL15.

Can not be compatible use with above three 10A Crimp contacts.

Stamped contacts 10A, for HD-040-MC/P, HD-040-FC/P, HD-064-MC/P, HD-064-FC/P inserts.

Contact resistance  $\leq 5m\Omega$ 

silver plated



coil stock



Wire gauge	Contacts	Female	Order No.
0.5-1.5mm <sup>2</sup>	male	CDSM-1.5P	101 017 110 0905
	female	CDSF-1.5P	101 017 120 0905
1.5-2.5mm <sup>2</sup>	male	CDSM-2.5P	101 017 110 1005
	female	CDSF-2.5P	101 017 120 1005

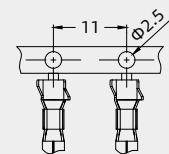

Distance map

Notes: The tools for crimp terminal may influence the product quality and stability. Please select the tools recognized by our company.

### Crimp contacts

#### Crimp contacts 16A-Standard, for HAC, HEC, HEE, HM, HK inserts.

Contact resistance  $\leq 1\text{m}\Omega$

silver plated



gold plated



Male	Order No.	Female	Order No.
CESM-0.37	101 019 110 0301	CESF-0.37	101 019 120 0301
CESM-0.50	101 019 110 0401	CESF-0.50	101 019 120 0401
CESM-0.75	101 019 110 0601	CESF-0.75	101 019 120 0601
CESM-1.0	101 019 110 0801	CESF-1.0	101 019 120 0801
CESM-1.5	101 019 110 0901	CESF-1.5	101 019 120 0901
CESM-2.5	101 019 110 1001	CESF-2.5	101 019 120 1001
CESM-3.0	101 019 110 1101	CESF-3.0	101 019 120 1101
CESM-4.0	101 019 110 1201	CESF-4.0	101 019 120 1201
CEGM-0.37	101 019 210 0301	CEGF-0.37	101 019 220 0301
CEGM-0.50	101 019 210 0401	CEGF-0.50	101 019 220 0401
CEGM-0.75	101 019 210 0601	CEGF-0.75	101 019 220 0601
CEGM-1.0	101 019 210 0801	CEGF-1.0	101 019 220 0801
CEGM-1.5	101 019 210 0901	CEGF-1.5	101 019 220 0901
CEGM-2.5	101 019 210 1001	CEGF-2.5	101 019 220 1001
CEGM-3.0	101 019 210 1101	CEGF-3.0	101 019 220 1101
CEGM-4.0	101 019 210 1201	CEGF-4.0	101 019 220 1201

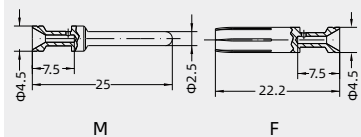

Identification	Wire gauge	Stripping length	
no groove	0.14-0.37 mm <sup>2</sup>	AWG 26-22	7.5mm
no groove	0.5 mm <sup>2</sup>	AWG 20	7.5mm
1 groove	0.75 mm <sup>2</sup>	AWG 18	7.5mm
1 groove	1 mm <sup>2</sup>	AWG 18	7.5mm
2 groove	1.5 mm <sup>2</sup>	AWG 16	7.5mm
3 groove	2.5 mm <sup>2</sup>	AWG 14	7.5mm
wide groove	3 mm <sup>2</sup>	AWG 12	7.5mm
no groove	4 mm <sup>2</sup>	AWG 12	7.5mm

When the wire gauge is less than 0.75mm<sup>2</sup>, it's better to use the auxiliary pin assembly tool TL15.

#### Crimp contacts 16A-Enhanced ( prevent deflected insertion , with crown spring), for HAC, HEC, HEE, HM, HK inserts.

Contact resistance  $\leq 1\text{m}\Omega$

silver plated



gold plated



Male	Order No.	Female	Order No.
CESM-0.37	101 019 110 0301	ZCESF-0.37G	101 019 120 0311
CESM-0.50	101 019 110 0401	ZCESF-0.50G	101 019 120 0411
CESM-0.75	101 019 110 0601	ZCESF-0.75G	101 019 120 0611
CESM-1.0	101 019 110 0801	ZCESF-1.0G	101 019 120 0811
CESM-1.5	101 019 110 0901	ZCESF-1.5G	101 019 120 0911
CESM-2.5	101 019 110 1001	ZCESF-2.5G	101 019 120 1011
CESM-3.0	101 019 110 1101	ZCESF-3.0G	101 019 120 1111
CESM-4.0	101 019 110 1201	ZCESF-4.0G	101 019 120 1211
CEGM-0.37	101 019 210 0301	ZCEGF-0.37G	101 019 220 0311
CEGM-0.50	101 019 210 0401	ZCEGF-0.50G	101 019 220 0411
CEGM-0.75	101 019 210 0601	ZCEGF-0.75G	101 019 220 0611
CEGM-1.0	101 019 210 0801	ZCEGF-1.0G	101 019 220 0811
CEGM-1.5	101 019 210 0901	ZCEGF-1.5G	101 019 220 0911
CEGM-2.5	101 019 210 1001	ZCEGF-2.5G	101 019 220 1011
CEGM-3.0	101 019 210 1101	ZCEGF-3.0G	101 019 220 1111
CEGM-4.0	101 019 210 1201	ZCEGF-4.0G	101 019 220 1211

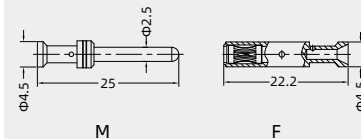

Identification	Wire gauge	Stripping length	
no groove	0.14-0.37 mm <sup>2</sup>	AWG 26-22	7.5mm
no groove	0.5 mm <sup>2</sup>	AWG 20	7.5mm
1 groove	0.75 mm <sup>2</sup>	AWG 18	7.5mm
1 groove	1 mm <sup>2</sup>	AWG 18	7.5mm
2 groove	1.5 mm <sup>2</sup>	AWG 16	7.5mm
3 groove	2.5 mm <sup>2</sup>	AWG 14	7.5mm
wide groove	3 mm <sup>2</sup>	AWG 12	7.5mm
no groove	4 mm <sup>2</sup>	AWG 12	7.5mm

When the wire gauge is less than 0.75mm<sup>2</sup>, it's better to use the auxiliary pin assembly tool TL15.

#### Crimp contacts 16A-Enhanced III ( prevent deflected insertion, with crown spring, recommended use in rail transport industry, vibration resistance), for HE-006-MC/N/FC/N, HEE-046-MC/N/FC/N inserts).

Contact resistance  $\leq 1\text{m}\Omega$

silver plated



gold plated



Male	Order No.	Female	Order No.
CESM-0.37/N	101 019 110 0302	CESF-0.37G/N	101 019 120 0302
CESM-0.50/N	101 019 110 0402	CESF-0.50G/N	101 019 120 0402
CESM-0.75/N	101 019 110 0602	CESF-0.75G/N	101 019 120 0602
CESM-1.0/N	101 019 110 0802	CESF-1.0G/N	101 019 120 0802
CESM-1.5/N	101 019 110 0902	CESF-1.5G/N	101 019 120 0902
CESM-2.5/N	101 019 110 1002	CESF-2.5G/N	101 019 120 1002
CESM-3.0/N	101 019 110 1102	CESF-3.0G/N	101 019 120 1102
CESM-4.0/N	101 019 110 1202	CESF-4.0G/N	101 019 120 1202
CEGM-0.37/N	101 019 210 0302	CEGF-0.37G/N	101 019 220 0302
CEGM-0.50/N	101 019 210 0402	CEGF-0.50G/N	101 019 220 0402
CEGM-0.75/N	101 019 210 0602	CEGF-0.75G/N	101 019 220 0602
CEGM-1.0/N	101 019 210 0802	CEGF-1.0G/N	101 019 220 0802
CEGM-1.5/N	101 019 210 0902	CEGF-1.5G/N	101 019 220 0902
CEGM-2.5/N	101 019 210 1002	CEGF-2.5G/N	101 019 220 1002
CEGM-3.0/N	101 019 210 1102	CEGF-3.0G/N	101 019 220 1102
CEGM-4.0/N	101 019 210 1202	CEGF-4.0G/N	101 019 220 1202

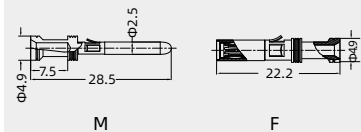

Identification	Wire gauge	Stripping length	
no groove	0.14-0.37 mm <sup>2</sup>	AWG 26-22	7.5mm
no groove	0.5 mm <sup>2</sup>	AWG 20	7.5mm
1 groove	0.75 mm <sup>2</sup>	AWG 18	7.5mm
1 groove	1 mm <sup>2</sup>	AWG 18	7.5mm
2 groove	1.5 mm <sup>2</sup>	AWG 16	7.5mm
3 groove	2.5 mm <sup>2</sup>	AWG 14	7.5mm
wide groove	3 mm <sup>2</sup>	AWG 12	7.5mm
no groove	4 mm <sup>2</sup>	AWG 12	7.5mm

When the wire gauge is less than 0.75mm<sup>2</sup>, it's better to use the auxiliary pin assembly tool TL15.

Can not be compatible use with above two 10A Crimp contacts.  
Male contact removal tool: TL00  
Female contact removal tool: TL09

Notes: The tools for crimp terminal may influence the product quality and stability. Please select the tools recognized by our company.

## Crimp contacts

Crimp contacts 16A - high mating cycles(mating cycles  $\geq 5000$ )Contact resistance  $\leq 1\text{m}\Omega$ 

gold plated



Male	Order No.	Female	Order No.
CEGMH-0.37	101 019 210 0309	CEGFH-0.37G	101 019 220 0309
CEGMH-0.50	101 019 210 0409	CEGFH-0.50G	101 019 220 0409
CEGMH-0.75	101 019 210 0609	CEGFH-0.75G	101 019 220 0609
CEGMH-1.0	101 019 210 0809	CEGFH-1.0G	101 019 220 0809
CEGMH-1.5	101 019 210 0909	CEGFH-1.5G	101 019 220 0909
CEGMH-2.5	101 019 210 1009	CEGFH-2.5G	101 019 220 1009
CEGMH-3.0	101 019 210 1109	CEGFH-3.0G	101 019 220 1109
CEGMH-4.0	101 019 210 1209	CEGFH-4.0G	101 019 220 1209

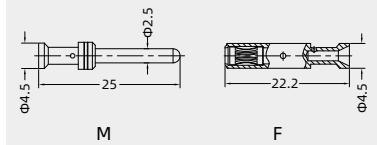

Identification	Wire gauge	Stripping length	
no groove	0.14-0.37 mm <sup>2</sup>	AWG 26-22	7.5mm
no groove	0.5 mm <sup>2</sup>	AWG 20	7.5mm
1 groove	0.75 mm <sup>2</sup>	AWG 18	7.5mm
1 groove	1 mm <sup>2</sup>	AWG 18	7.5mm
2 groove	1.5 mm <sup>2</sup>	AWG 16	7.5mm
3 groove	2.5 mm <sup>2</sup>	AWG 14	7.5mm
wide groove	3 mm <sup>2</sup>	AWG 12	7.5mm
no groove	4 mm <sup>2</sup>	AWG 12	7.5mm

When the wire gauge is less than 0.75mm<sup>2</sup>, it's better to use the auxiliary pin assembly tool TL15.

Notes: The tools for crimp terminal may influence the product quality and stability. Please select the tools recognized by our company.



## Crimp contacts

## Crimp contacts 40A-Standard, for HM, HK inserts.

Contact resistance  $\leq 1\text{m}\Omega$ 

silver plated



gold plated



Male	Order No.	Female	Order No.
CCSM-1.5	101 023 110 0901	CCSF-1.5	101 023 120 0901
CCSM-2.5	101 023 110 1001	CCSF-2.5	101 023 120 1001
CCSM-4.0	101 023 110 1201	CCSF-4.0	101 023 120 1201
CCSM-6.0	101 023 110 1301	CCSF-6.0	101 023 120 1301
CCSM-10.0	101 023 110 1401	CCSF-10.0	101 023 120 1401
CCGM-1.5	101 023 210 0901	CCGF-1.5	101 023 220 0901
CCGM-2.5	101 023 210 1001	CCGF-2.5	101 023 220 1001
CCGM-4.0	101 023 210 1201	CCGF-4.0	101 023 220 1201
CCGM-6.0	101 023 210 1301	CCGF-6.0	101 023 220 1301
CCGM-10.0	101 023 210 1401	CCGF-10.0	101 023 220 1401

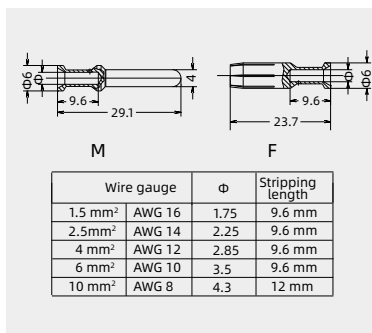

## Crimp contacts 40A-Enhanced (prevent deflected insertion, high mating cycle, with crown spring), for HK inserts.

Contact resistance  $\leq 1\text{m}\Omega$ 

gold plated



Male	Order No.	Female	Order No.
CCGMH-1.5	101 023 210 0909	CCGFH-1.5G	101 023 220 0909
CCGMH-2.5	101 023 210 1009	CCGFH-2.5G	101 023 220 1009
CCGMH-4.0	101 023 210 1209	CCGFH-4.0G	101 023 220 1209
CCGMH-6.0	101 023 210 1309	CCGFH-6.0G	101 023 220 1309
CCGMH-10.0	101 023 210 1409	CCGFH-10.0G	101 023 220 1409

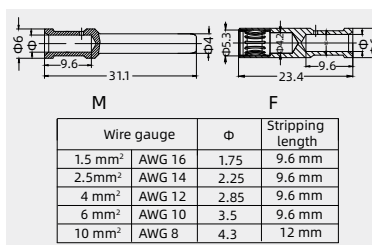

## Crimp contacts 70A, for HM inserts.

Contact resistance  $\leq 0.5\text{m}\Omega$ 

silver plated



Male	Order No.	Female	Order No.
CKSM70-6	101 034 110 1301	CKSF70-6	101 034 120 1301
CKSM70-10	101 034 110 1401	CKSF70-10	101 034 120 1401
CKSM70-16	101 034 110 1501	CKSF70-16	101 034 120 1501
CKSM70-25	101 034 110 1601	CKSF70-25	101 034 120 1601

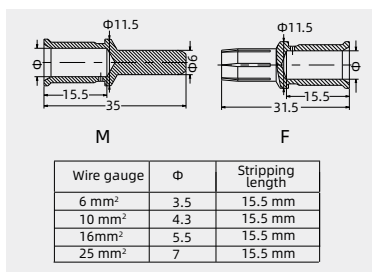

## Crimp contacts 100A (with crown spring), for HM, HK inserts.

Contact resistance  $\leq 0.3\text{m}\Omega$ 

silver plated



Male	Order No.	Female	Order No.
CKSM-10	101 026 110 1401	CKSF-10G	101 026 120 1403
CKSM-16	101 026 110 1501	CKSF-16G	101 026 120 1503
CKSM-25	101 026 110 1601	CKSF-25G	101 026 120 1603
CKSM-35	101 026 110 1701	CKSF-35G	101 026 120 1703

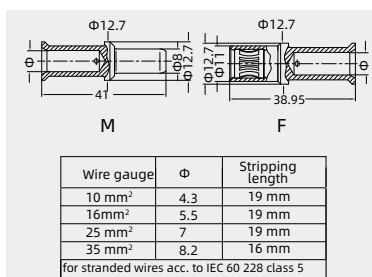

## Crimp contacts 200A, for HM inserts.

Contact resistance  $\leq 0.3\text{m}\Omega$ 

silver plated



Male	Order No.	Female	Order No.
CHSM200-25	101 027 110 1601	CHSF200-25	101 027 120 1601
CHSM200-35	101 027 110 1701	CHSF200-35	101 027 120 1701
CHSM200-50	101 027 110 1801	CHSF200-50	101 027 120 1801
CHSM200-70	101 027 110 1901	CHSF200-70	101 027 120 1901

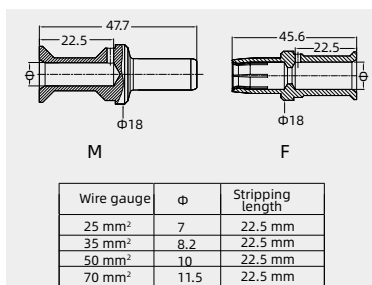

Notes: The tools for crimp terminal may influence the product quality and stability. Please select the tools recognized by our company.

## Crimp contacts

## Crimp contacts 250A (with crown spring), for HC250 inserts.

Contact resistance  $\leq 0.3m\Omega$ 

silver plated

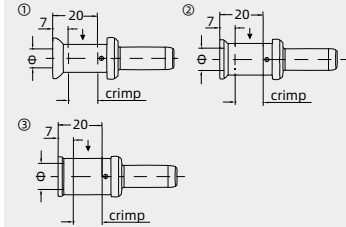

No.	Male	Order No.	Female	Order No.
①	CHSM250-35	101 028 110 1701	CHSF250-35G	101 028 120 1703
②	CHSM250-50	101 028 110 1801	CHSF250-50G	101 028 120 1803
③	CHSM250-70	101 028 110 1901	CHSF250-70G	101 028 120 1903

For stranded wire acc. to IEC 60 228-5  
Crimp zone acc. to DIN 46 235

NO.	Wire gauge	$\Phi$	Stripping length
①	35 mm <sup>2</sup>	8.45 mm	22 mm
②	50 mm <sup>2</sup>	10.25mm	22 mm
③	70 mm <sup>2</sup>	11.75 mm	22 mm

## Crimp contacts 300A , for H2MK 300 inserts.

Contact resistance  $\leq 0.3m\Omega$ 

silver plated



Male	Order No.	Order No.	订货号
CHSM300-70	101 041 110 1950	CHSF300-70	101 041 120 1950
CHSM300-95	101 041 110 2050	CHSF300-95	101 041 120 2050
CHSM300-120	101 041 110 2150	CHSF300-120	101 041 120 2150

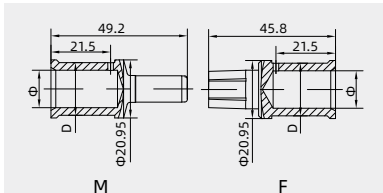

Wire gauge	$\Phi$	D	Stripping length
70 mm <sup>2</sup>	11.5	16.5mm	23.5 mm 22 mm
95 mm <sup>2</sup>	13.5	19mm	23.5 mm 22 mm
120 mm <sup>2</sup>	15.5	20,95mm	23.5 mm 22 mm

When the outer diameter of the insulation skin is  $\geq 22$ mm, the stripping length of the male pole is 31mm, and the stripping length of the female pole is 29.5m

## Crimp contacts 350A (with crown spring), for HC350 inserts.

Contact resistance  $\leq 0.3m\Omega$ 

silver plated

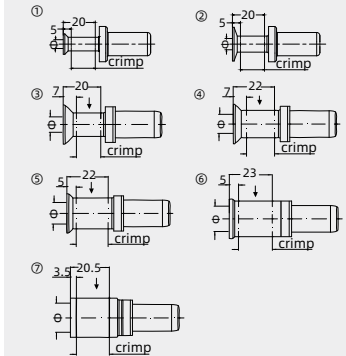

No.	Male	Order No.	Female	Order No.
①	CHSM350-16	101 029 110 1501	CHSF350-16G	101 029 120 1501
②	CHSM350-25	101 029 110 1600	CHSF350-25G	101 029 120 1601
③	CHSM350-35	101 029 110 1701	CHSF350-35G	101 029 120 1703
④	CHSM350-50	101 029 110 1801	CHSF350-50G	101 029 120 1803
⑤	CHSM350-70	101 029 110 1901	CHSF350-70G	101 029 120 1903
⑥	CHSM350-95	101 029 110 2001	CHSF350-95G	101 029 120 2003
⑦	CHSM350-120	101 029 110 2101	CHSF350-120G	101 029 120 2103

For stranded wire acc. to IEC 60 228-5  
Crimp zone acc. to DIN 46 235

NO.	Wire gauge	$\Phi$	Stripping length
①	16 mm <sup>2</sup>	5.5 mm	26 mm
②	25 mm <sup>2</sup>	7 mm	26 mm
③	35 mm <sup>2</sup>	8.2 mm	26 mm
④	50 mm <sup>2</sup>	10.0mm	28 mm
⑤	70 mm <sup>2</sup>	11.5 mm	28 mm
⑥	95 mm <sup>2</sup>	13.5 mm	30 mm
⑦	120 mm <sup>2</sup>	15.5 mm	24 mm

Notes: The tools for crimp terminal may influence the product quality and stability. Please select the tools recognized by our company.

## Crimp contacts

## Crimp contacts 650A (with crown spring), for HC650 inserts.

Contact resistance  $\leq 0.3\text{m}\Omega$ 

silver plated

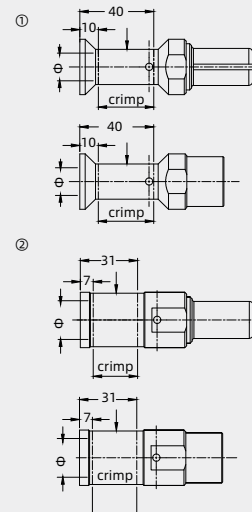

No.	Male	Order No.	Female	Order No.
①	CHSM650-95	101 030 110 2002	CHSF650-95G	101 030 120 2002
①	CHSM650-120	101 030 110 2101	CHSF650-120G	101 030 120 2101
①	CHSM650-150	101 030 110 2202	CHSF650-150G	101 030 120 2202
②	CHSM650-185	101 030 110 2301	CHSF650-185G	101 030 120 2303
②	CHSM650-240	101 030 110 2401	CHSF650-240G	101 030 120 2403

For stranded wire acc. to IEC 60 228-5  
Crimp zone acc. to DIN 46 235

NO.	Wire gauge	$\Phi$	Stripping length
①	95 mm <sup>2</sup>	13.5 mm	42 mm
	120 mm <sup>2</sup>	15.5 mm	42 mm
	150 mm <sup>2</sup>	17 mm	42 mm
②	185 mm <sup>2</sup>	19.4 mm	46 mm
	240 mm <sup>2</sup>	22.5 mm	46 mm

## Crimp contacts 1000A , for HC1000 inserts.

Contact resistance  $\leq 0.3\text{m}\Omega$ 

silver plated

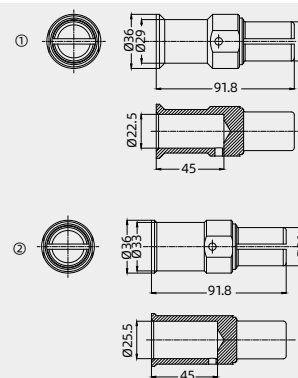

No.	Male	Order No.	Female	Order No.
①	CHSM1000-240	101 042 110 2401	CHSF1000-240G	101 042 120 2401
②	CHSM1000-300	101 042 110 3551	CHSF1000-300G	101 042 120 3551

Relay contact<sup>2)</sup>

silver plated



Wire gauge(mm <sup>2</sup> )	Designation	Order No.
1	CESM-1.0R	101 019 110 0808
1.5	CESM-1.5R	101 019 110 0908
2.5	CESM-2.5R	101 019 110 1008

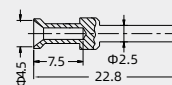







Identification	Wire gauge	Stripping length
1 groove	1 mm <sup>2</sup> AWG 18	7.5mm
2 groove	1.5 mm <sup>2</sup> AWG 16	7.5mm
3 groove	2.5 mm <sup>2</sup> AWG 14	7.5mm

Notes: The tools for crimp terminal may influence the product quality and stability. Please select the tools recognized by our company.

2) Delay pin is relatively short, delay contact, protect circuit to avoid electric arc. (General use: connect electrical signal with conventional pin, connect control signal with delay pin, contact of delay pin is later than that of conventional pin. After contacting delay pin in the insertion process, control signal of circuit is connected.)

## Crimp contacts

## Difference comparison of contact pins

D contacts				
	Standard	Enhanced I	Enhanced II	Enhanced III
Difference	Standard model, combined with standard D-type DD-type core body; the product adopts D-type metal dome positioning, leaf spring throat will provide positive pressure for retention of female contact pin.	Equipped with stainless steel bushing, and combined with standard D-type DD-type core body. 1. Product can avoid "tongue pressing" deformation and invalid contact of traditional open structure due to poor guiding or sudden situation. 2. Product adopts D-type metal dome positioning, leaf spring throat will provide positive pressure for retention of female contact pin. Tongue piece is always restricted within the elastic deformation scope of bushing.	1. Unique elastic structure of $\Phi 1.6$ jack socket uses beryllium copper as elastomer. In addition to the above advantages, it can avoid "tongue pressing" deformation and invalid contact of traditional open structure due to poor guiding or sudden situation. Contact pin adopts two-pad structure as the right figure shows to guarantee that supporting is more reliable and can completely be compatible with existing similar cold pressing pin. 2. Compared with split slot type jack socket, characteristics of crown spring type jack socket include: embedded with beryllium bronze multi-reed connection, it has excellent elastic performance after treatment, and fatigue life can reach 5,000 times. Beryllium bronze alloy is featured with high intensity, high elasticity and no magnetism through smelting, casting, hot rolling and special thermal treatment, which can be called as the king of elasticity of non-ferrous metals. Therefore, it is widely applied in spaceflight, aviation, rail transit, manufacturing electronic element, electric parts, and component of resistance welding equipment. In particular, it has larger advantages when it is used for elastic connectors.	Three-pad supporting, combined with standard D-type DD-type core body. The product uses three-pad metal dome positioning so that supporting and positioning are more uniform and stable. It is more suitable for vibration occasion. Leaf spring throat will provide positive pressure for retention of female contact pin.
E contacts				
	Standard	Enhanced	Enhanced III	
Difference	Standard model, combined with standard E-type EE-type cold pressing core body; leaf spring throat will provide positive pressure for retention of female contact pin.	1. Product can avoid "tongue pressing" deformation and invalid contact of traditional open structure due to poor guiding or sudden situation. 2. Compared with split slot type jack socket, characteristics of crown spring type jack socket include: embedded with beryllium bronze multi-reed connection, it has excellent elastic performance after treatment, and fatigue life can reach 5,000 times. Beryllium bronze alloy is featured with high intensity, high elasticity and no magnetism through smelting, casting, hot rolling and special thermal treatment, which can be called as the king of elasticity of non-ferrous metals. Therefore, it is widely applied in spaceflight, aviation, rail transit, manufacturing electronic element, electric parts, and component of resistance welding equipment. In particular, it has larger advantages when it is used for elastic connectors.	The product adopts N plug (such as HE-006-FC/N) and three-pad jack catch to position that will not be affected by conductor. So that supporting and positioning are more uniform and stable. It is more suitable for vibration occasion. Meanwhile, female contact pin is used together with standard E-type EE-type cold pressing core body. 1. Product can avoid "tongue pressing" deformation and invalid contact of traditional open structure due to poor guiding or sudden situation. 2. Compared with split slot type jack socket, characteristics of crown spring type jack socket include: embedded with beryllium bronze multi-reed connection, it has excellent elastic performance after treatment, and fatigue life can reach 5,000 times. Beryllium bronze alloy is featured with high intensity, high elasticity and no magnetism through smelting, casting, hot rolling and special thermal treatment, which can be called as the king of elasticity of non-ferrous metals. Therefore, it is widely applied in spaceflight, aviation, rail transit, manufacturing electronic element, electric parts, and component of resistance welding equipment. In particular, it has larger advantages when it is used for elastic connectors. Its main characteristics include: 1. Plug structure is simple; 2. As it uses beryllium copper three-pad clamp spring, it will not age or break like plastic jack catch of conventional product.	

Notes: The tools for crimp terminal may influence the product quality and stability. Please select the tools recognized by our company.

## Rectangular connector-Accessories

	Page
PCB-adapter	P14-02~P14-11
Rail bracket	P14-12~P14-13
Ground terminal/Docking frame	P14-14~P14-16
Code pin	P14-17~14-18
Cable clamp	P14-19

## HDD inserts with PCB-adapter



### Technical characteristics

Specifications	DIN EN 60 664 DIN EN 61 984
Approvals	UL CE ENEC CCC
inserts	
Number of contacts	24,42,72,108
Electrical data acc. to EN 61 984	
-Rated current	7.5A
-Rated voltage	250V
-Rated impulse voltage	4kV
-Pollution degree	3
Rated voltage acc. to UL	250V
Testing voltage Ueff	2kV
Insulation resistance	$\geq 10^{10}\Omega$
Material	polycarbonate
Limiting temperatures	-40°C ...+125°C
Flammability acc. to UL 94	V0
Mechanical working life(mating cycles)	$\geq 500$

### Layout of PCB

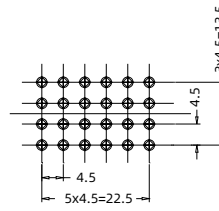

H24DD

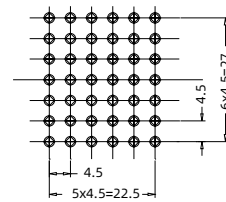

H42DD

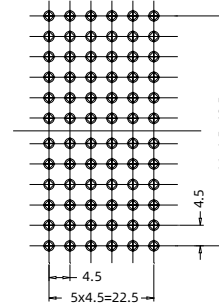

H72DD

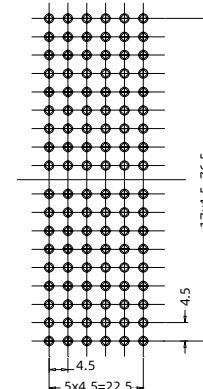

H108DD

# HDD inserts with PCB-adapter

## Assembly situation

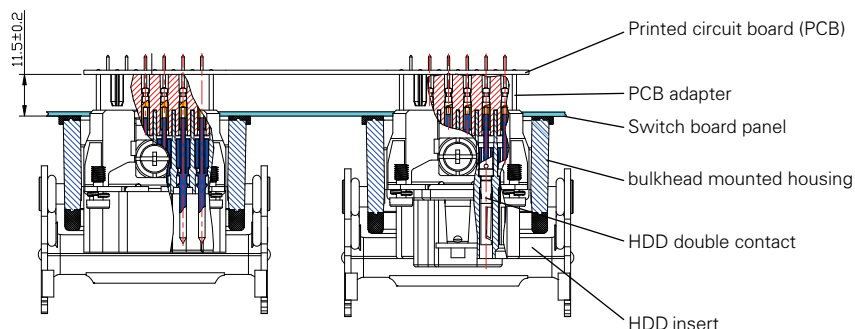

### HDD insert



Insert	Size	Designation	Order No.
Male	H6B	HDD-024-MC	126 024 010 0001
	H10B	HDD-042-MC	126 042 010 0001
	H16B	HDD-072-MC	126 072 010 0001
Female	H24B	HDD-108-MC	126 108 010 0001
	H6B	HDD-024-FC	126 024 020 0001
	H10B	HDD-042-FC	126 042 020 0001
	H16B	HDD-072-FC	126 072 020 0001
	H24B	HDD-108-FC	126 108 020 0001

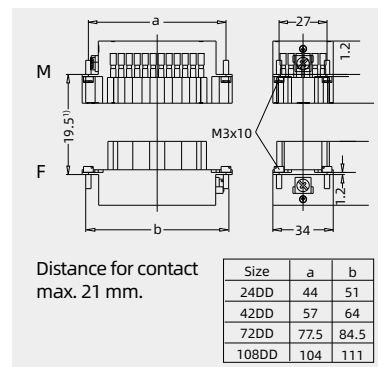

### PCB adapter



Description	Designation	Order No.
for PCBs up to 1.6mm	APT-6DD16	198 002 007 0002
for PCBs up to 2.4mm	APT-6DD24	198 002 007 0004

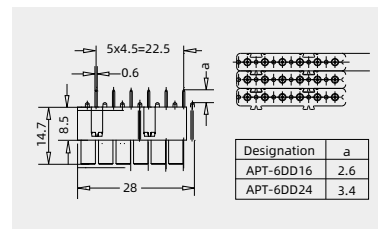

### HDD double contact



Contact	Designation	Order No.
Male	CDSM-P1.0	101 017 114 0001
Female	CDSF-P1.0	101 017 124 0001

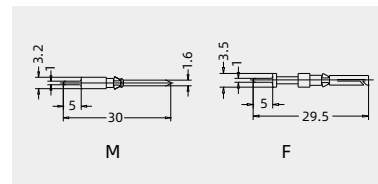

### Hoods/Housings

Hoods: further information see chapter DD

Bulkhead mounted housings: further information see chapter DD

## HEC inserts

## HEC inserts with PCB-adapter



## Technical characteristics

Specifications	DIN EN 60 664 DIN EN 61 984
Approvals inserts	
Number of contacts	6,10,16,24
Electrical data acc. to EN 61 984	
-Rated current	16A
-Rated voltage	500V
-Rated impulse voltage	6kV
-Pollution degree	3
Insulation resistance	$\geq 10^{10}\Omega$
Material	polycarbonate
Limiting temperatures	-40°C ...+125°C
Flammability acc. to UL 94	V0
Mechanical working life(mating cycles)	$\geq 500$

## Layout of PCB

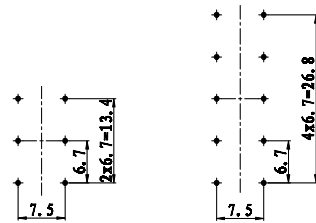

6E

10E

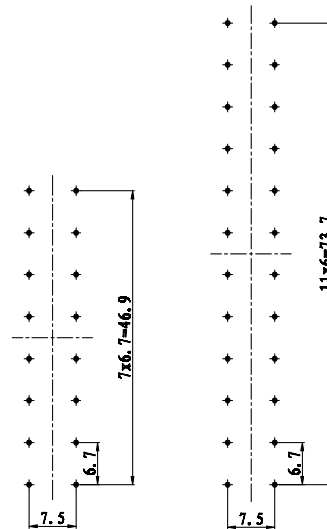

16E

24E



# HEC inserts with PCB-adapter

## Assembly situation

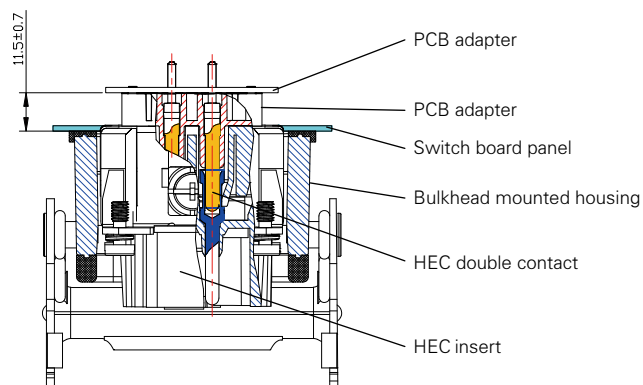

### HEC insert



Insert	Size	Designation	Order No.
Male	6B	HE-006-MC	122 006 010 0001
	10B	HE-010-MC	122 010 010 0001
	16B	HE-016-MC	122 016 010 0001
	24B	HE-024-MC	122 024 010 0001
Female	6B	HE-006-FC	122 006 020 0001
	10B	HE-010-FC	122 010 020 0001
	16B	HE-016-FC	122 016 020 0001
	24B	HE-024-FC	122 024 020 0001

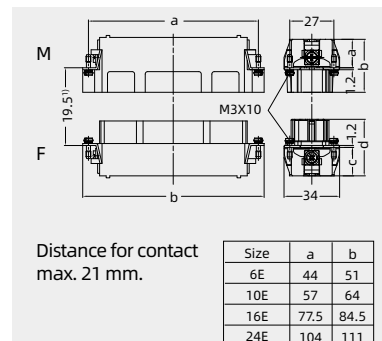

### PCB adapter



Description	Designation	Order No.
	APT-2E16	198 002 007 0001

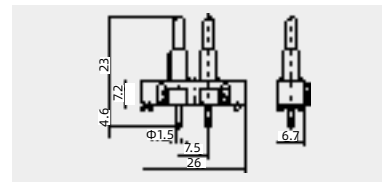

### HEC double contact



Contact	Designation	Order No.
Male	CESM-2.5P	101 019 114 0051
Female	CESF-2.5P	101 019 124 0051

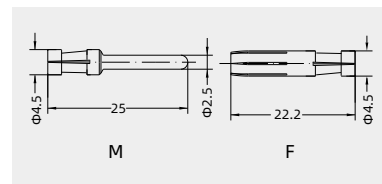

### Hoods/Housings

Hoods: further information see chapter HE

Bulkhead mounted housings: further information see chapter HE

## HQ-004/2 inserts

## HQ-004/2 inserts with PCB-adapter



### Technical characteristics

Specifications	DIN EN 60 664	DIN EN 61 984
Approvals		
inserts		
Number of contacts	4/2	
Electrical data acc. to EN 61 984		
Power area		
-Rated current	30A	
-Rated voltage conductor - ground	400V	
-Rated voltage conductor - conductor	690V	
-Rated impulse voltage	6kV	
-Pollution degree	2	
Signal area		
-Rated current	7.5A	
-Rated voltage	250V	
-Rated impulse voltage	4kV	
-Pollution degree	2	
Insulation resistance	$\geq 10^{10} \Omega$	
Material	LCP	
Limiting temperatures	-40°C ...+125°C	
Flammability acc. to UL 94	V0	

### Layout of PCB

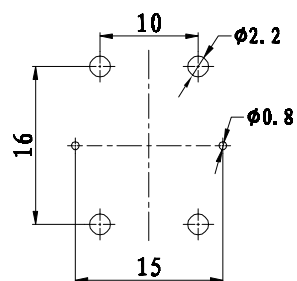

# HQC inserts with PCB-adapter

## Assembly situation

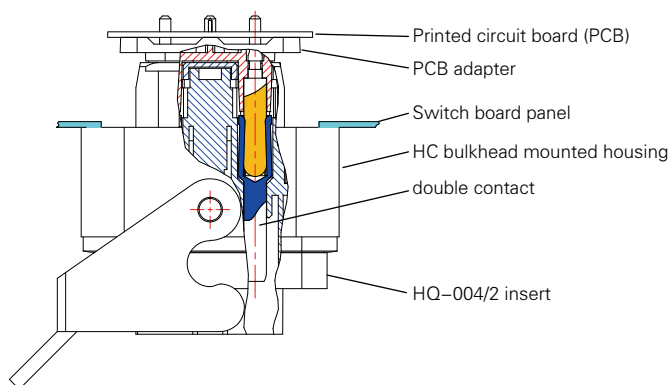

### HQ insert



Insert	Designation	Order No.
Male	HQ-004/2-MC	130 006 010 0001
Female	HQ-004/2-FC	130 006 020 0001

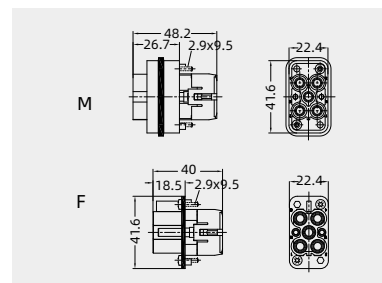

### PCB adapter



Description	Designation	Order No.
	APT-Q4/2	198 002 007 0009

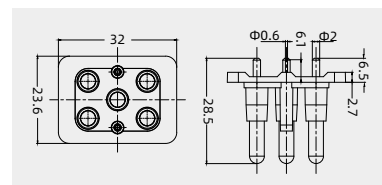

### C double contact, to connect the PCP-Adapter, Power contacts



Contact	Designation	Order No.
Male	CCSM-4.0P	101 023 114 1251
Female	CCSF-4.0P	101 023 124 1251

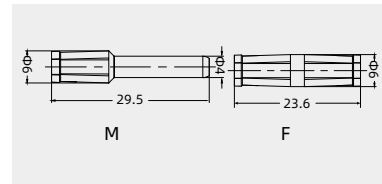

### D double contact, Signal contacts



Contact	Designation	Order No.
Male	CDSM-P1.0	101 017 114 0001
Female	CDSF-P1.0Q	101 017 124 0052

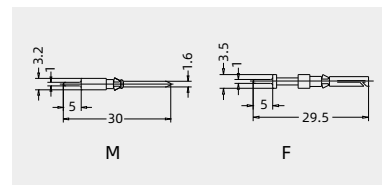

### HC bulkhead mounted housings



Thread	Designation	Order No.
---	HC.P-BK-1L	130 008 327 1001

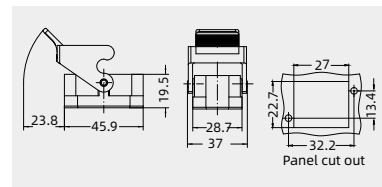

A

## HQ-007/0 inserts

## HQ-007/0 inserts with PCB-adapter



### Technical characteristics

Specifications	DIN EN 60 664 DIN EN 61 984
Approvals	UL VDE CE ENE CCC
inserts	
Number of contacts	7
Electrical data acc. to EN 61 984	
-Rated current	7.5A
-Rated voltage	250V
-Rated impulse voltage	4kV
-Pollution degree	3
Insulation resistance	$\geq 10^{10}\Omega$
Material	polycarbonate
Limiting temperatures	-40°C ...+125°C
Flammability acc. to UL 94	V0
Mechanical working life(mating cycles)	$\geq 500$

### Layout of PCB

recommended hole diameter: 0.8 mm

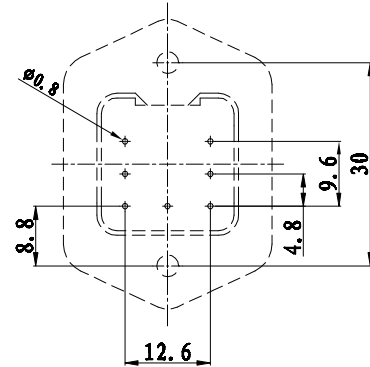

# HQ-007/0 inserts with PCB-adapter

## Assembly situation

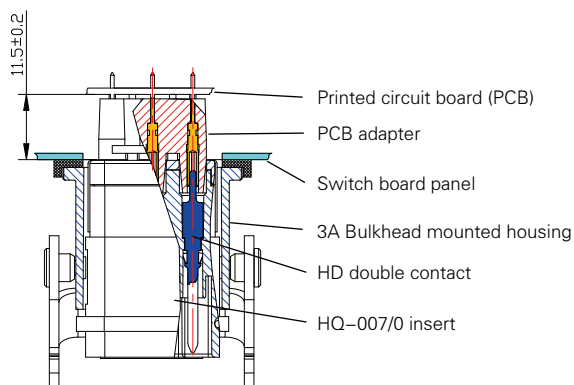

### HQ-007/0 insert



Insert	Designation	Order No.
Male	HQ-007/0-MC	130 007 010 0001
Female	HQ-007/0-FC	130 007 020 0001

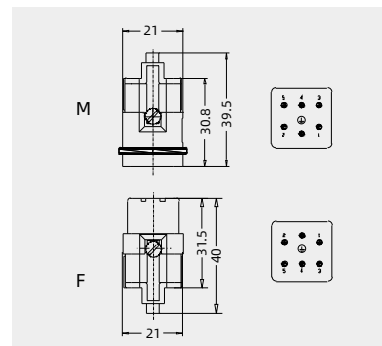

### PCB adapter



Description	Designation	Order No.
for PCBs up to 2.4mm	APT-Q7	198 002 007 0010

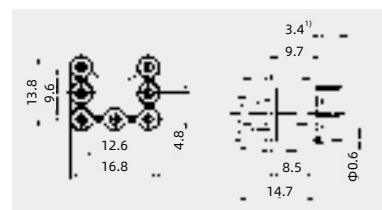

### HD double contact



Contact	Designation	Order No.
Male	CDSM-P1.0S	101 017 114 0002
Female	CDSF-P1.0S	101 017 124 0002

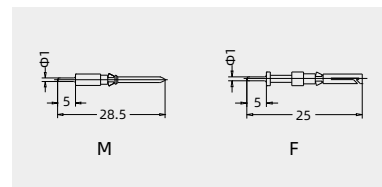

### 3A Bulkhead mounted housings



Thread	Designation	Order No.
---	H3A-BK-1L/W	110 003 324 1001

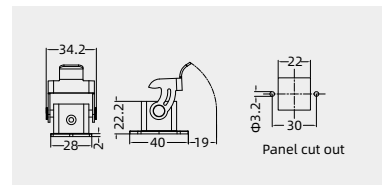

A

## HQ-008/0 inserts

## HQ-008/0 inserts with PCB-adapter



### Technical characteristics

Specifications	DIN EN 60 664	DIN EN 61 984
Approvals		
inserts		
Number of contacts	8/0	
Electrical data acc. to EN 61 984		
Rated current	16A	
Rated voltage conductor - ground	230V	
Rated voltage conductor - conductor	400V	
Rated impulse voltage	4kV	
Pollution degree	2	
Insulation resistance	$\geq 10^{10}\Omega$	
Material	LCP	
Limiting temperatures	-40°C ...+125°C	
Flammability acc. to UL 94	V0	

### Layout of PCB

dimensions in mm

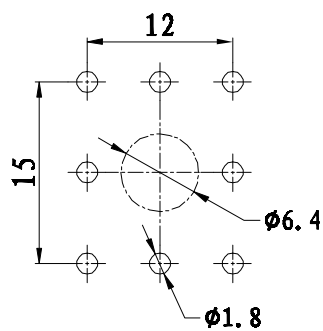

# HQC inserts with PCB-adapter

## Assembly situation

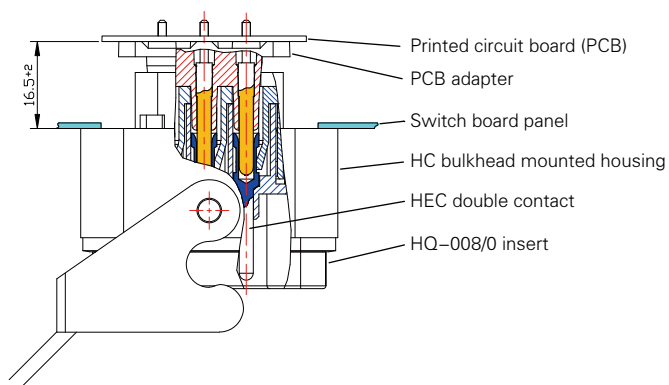

### HQ insert



Insert	Designation	Order No.
Male	HQ-008/0-MC	130 008 010 0001
Female	HQ-008/0-FC	130 008 020 0001

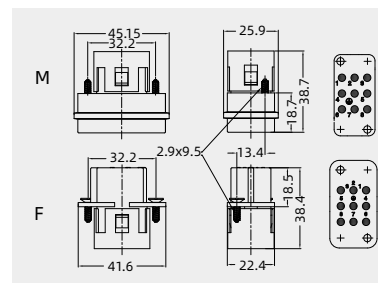

### PCB adapter



Description	Designation	Order No.
	APT-Q8	198 002 007 0011

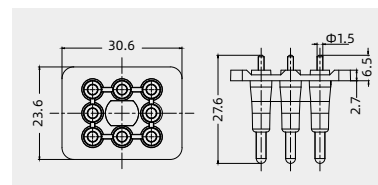

### HEC double contact, to connect the PCP-Adapter



Contact	Designation	Order No.
Male	CESM-2.5P	101 019 114 0051
Female	CESF-2.5P	101 019 124 0051

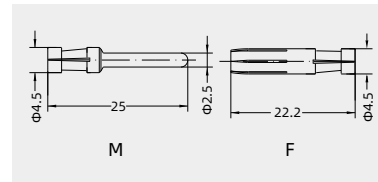

### HC Bulkhead mounted housings



Thread	Designation	Order No.
---	HC.P-BK-1L	130 008 327 1001

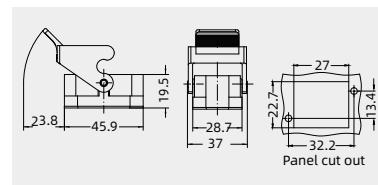

A

# Rail bracket

Is used to connect inserts fixed to the commonly used standard lateral rail.

A version



Size	Designation	Order No.
6B	CC6B	198 002 008 0009
10B	CC10B	198 002 008 0010
16B	CC16B	198 002 008 0011
24B	CC24B	198 002 008 0012

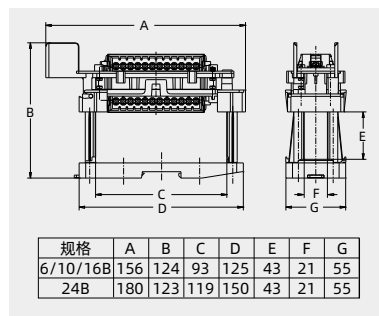

A

## Assembly instructions

A version

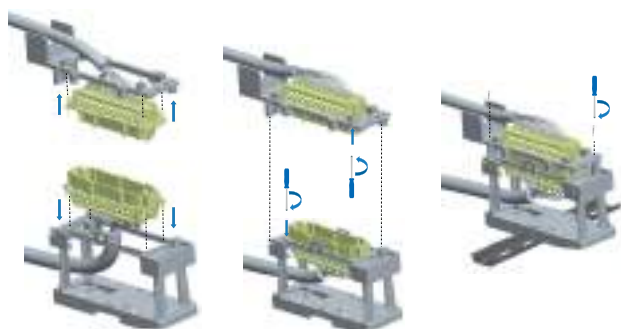

Is used to bulkhead mounted housings fixed to the commonly used standard lateral rail.



Size	Designation	Order No.
6B	CC6B-BK	198 002 008 0005
10B	CC10B-BK	198 002 008 0006
16B	CC16B-BK	198 002 008 0007
24B	CC24B-BK	198 002 008 0008

## Assembly instructions

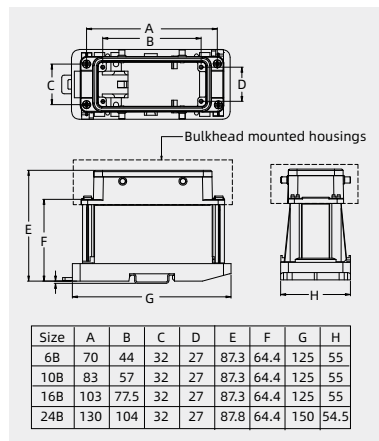



# Rail bracket

Is used to connect inserts fixed to the commonly used standard lateral rail. **Adjustable rail bracket**

## B version Rail bracket

### Latching parts with strain relief

### Latching parts

### Adjustable movable base

Description	Designation	Order No.
Suitable for all the inserts & module framework which match type B hood & housing	CCAB <sup>1)</sup>	198 002 008 0013

1) CCAB is a combined suite including: Latching parts with strain relief, Latching parts, Adjustable movable base

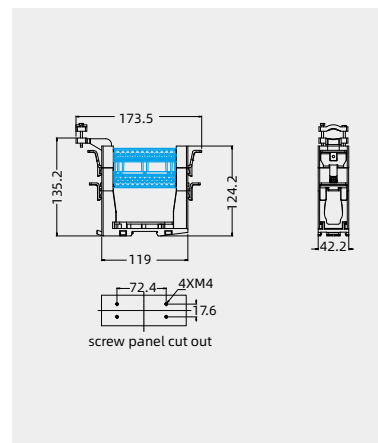

### Protecting cover can match CCAB

Description	Designation	Order No.
Play the protective role for insert.	CC6B-CV	198 002 008 0001
	CC10B-CV	198 002 008 0002
	CC16B-CV	198 002 008 0003
	CC24B-CV	198 002 008 0004

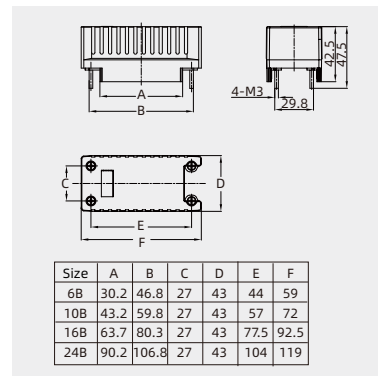

## Assembly instructions



## Adjustable movable base

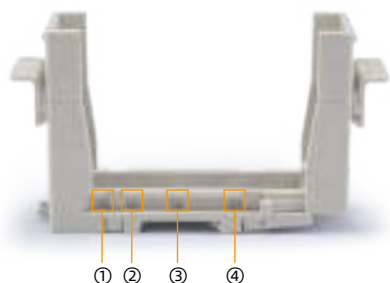

- ①: the insert and 6B version highed frame are matchable with 6B version shells
- ②: the insert and 10B version highed frame are matchable with 10B version shells
- ③: the insert and 16B version highed frame are matchable with 16B version shells
- ④: the insert and 24B version highed frame are matchable with 24B version shells

Ground terminal

Ground terminal-standard(for HE/HEE/HDD inserts in housings and hoods, high construction)

See P14-16 for assembly instructions

A

Size	Designation	Order No.
6B	B6B-PE	198 002 003 0001

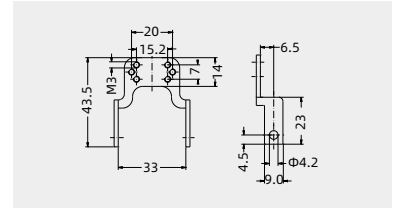

Size	Designation	Order No.
10B	B10B-PE	198 002 003 0002

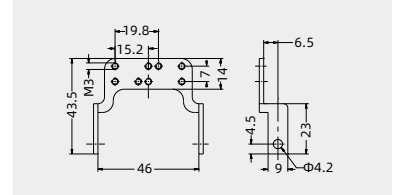

Size	Designation	Order No.
16B	B16B-PE	198 002 003 0003

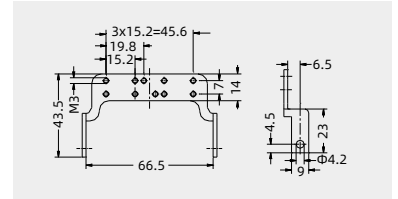

Size	Designation	Order No.
24B	B24B-PE	198 002 003 0004

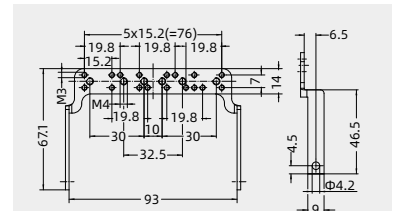

Size	Designation	Order No.
24B	B24B-PES	198 002 003 0005

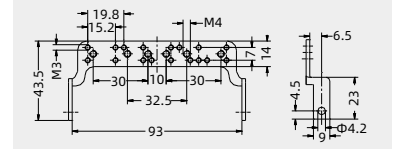

Ground terminal-for hinged frame(for HM frames in bulkhead mounted housings)

See P14-16 for assembly instructions

Size	Designation	Order No.
6B	M6B-PE	198 002 003 0008



Not suitable for P10-41~10-44 shielding modules

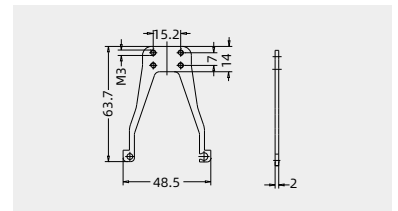

Size	Designation	Order No.
10B	M10B-PE	198 002 003 0009



Not suitable for P10-41~10-44 shielding modules

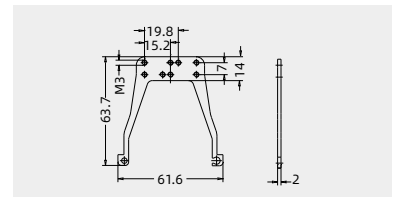

## Ground terminal/Grip frame/Screw adaptor/Clamps

### Ground terminal-for hinged(for HM frames in bulkhead mounted housings)

See P14-16 for assembly instructions



Size	Designation	Order No.
16B	M16B-PE	198 002 003 0010

Not suitable for P10-41~10-44 shielding modules

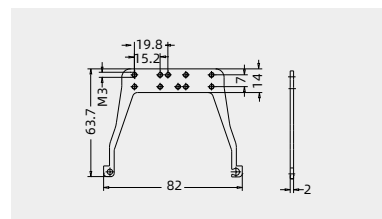

Size	Designation	Order No.
24B	M24B-PE	198 002 003 0014

Not suitable for P10-41~10-44 shielding modules

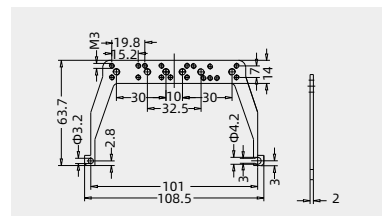

### Grip frame-with screw adaptor and screw



Size	Designation	Description	Order NO.
24B	GB-24B	blue	198 002 003 0006
24B	GB-24B-APT	with screw adaptor	198 002 003 0007

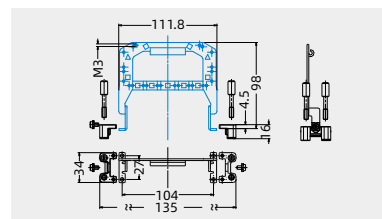

### Screw adaptor



Size	Designation	Description	Order NO.
---	S-APT01	blue	198 002 007 0012
---	S-APT02	blue	198 002 007 0014

Note: A complete set of adaptors requires an order of 2pcs per each

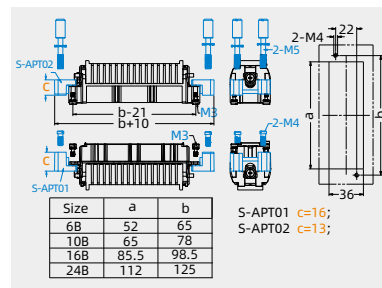

### Screw adaptor



Size	Designation	Order No.
---	CLP4.5-PE	198 002 003 0016

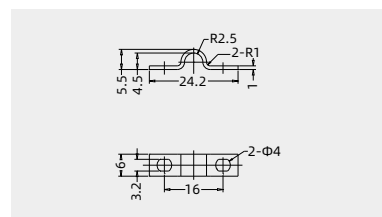

Size	Designation	Order No.
---	CLP10-PE	198 002 003 0017

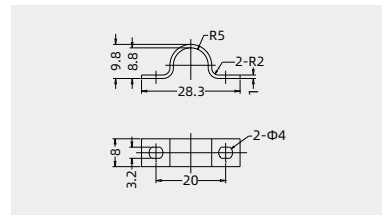

Ground terminal/Grip frame/Screw adaptor/Clamps

Ground terminal-for hinged(for HM frames in bulkhead mounted housings)

See P14-16 for assembly instructions



Size	Designation	Order No.
6B	M6B/E-PE	198 002 003 0039

Suitable for P10-41~10-44 shielding modules

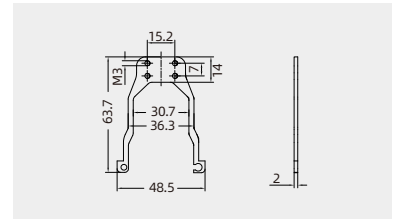

Size	Designation	Order No.
10B	M10B/E-PE	198 002 003 0040

Suitable for P10-41~10-44 shielding modules

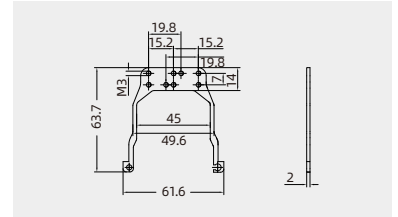

Size	Designation	Order No.
16B	M16B/E-PE	198 002 003 0041

Suitable for P10-41~10-44 shielding modules

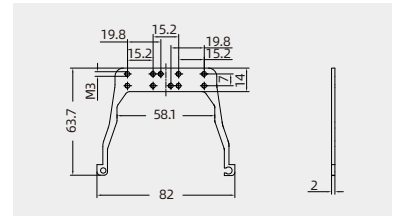

Size	Designation	Order No.
24B	M24B/E-PE	198 002 003 0042

Suitable for P10-41~10-44 shielding modules

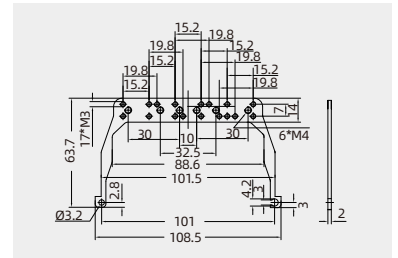

## Ground terminal assembly

## Ground terminal-standard(for HE/HEE/HDD inserts in housings and hoods, high construction)

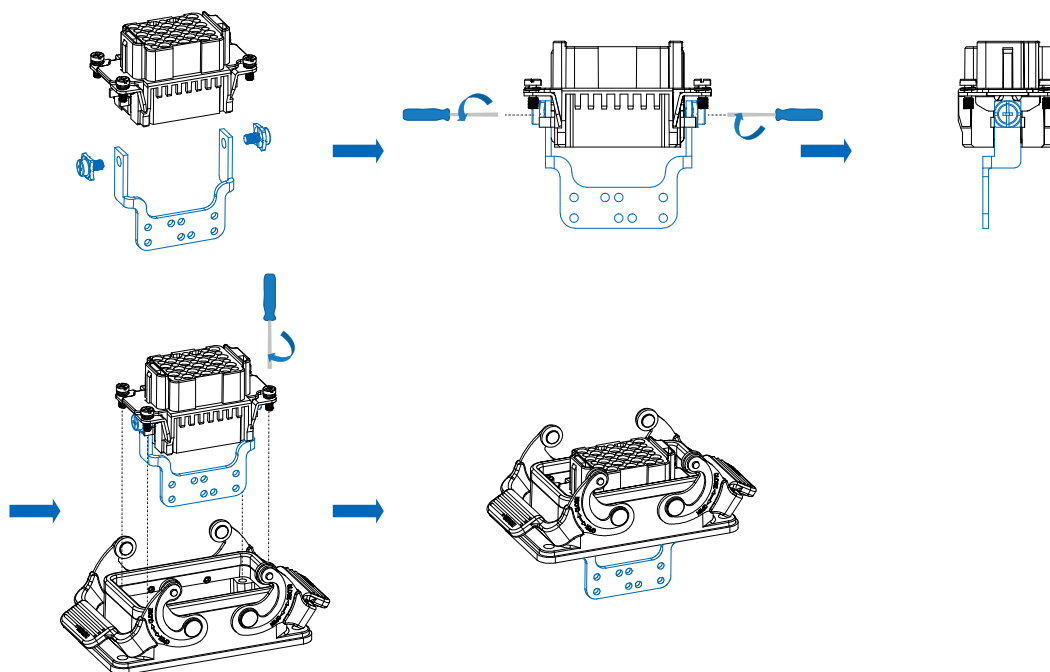

## Ground terminal-for hinged frame(for HM frames in bulkhead mounted housings)

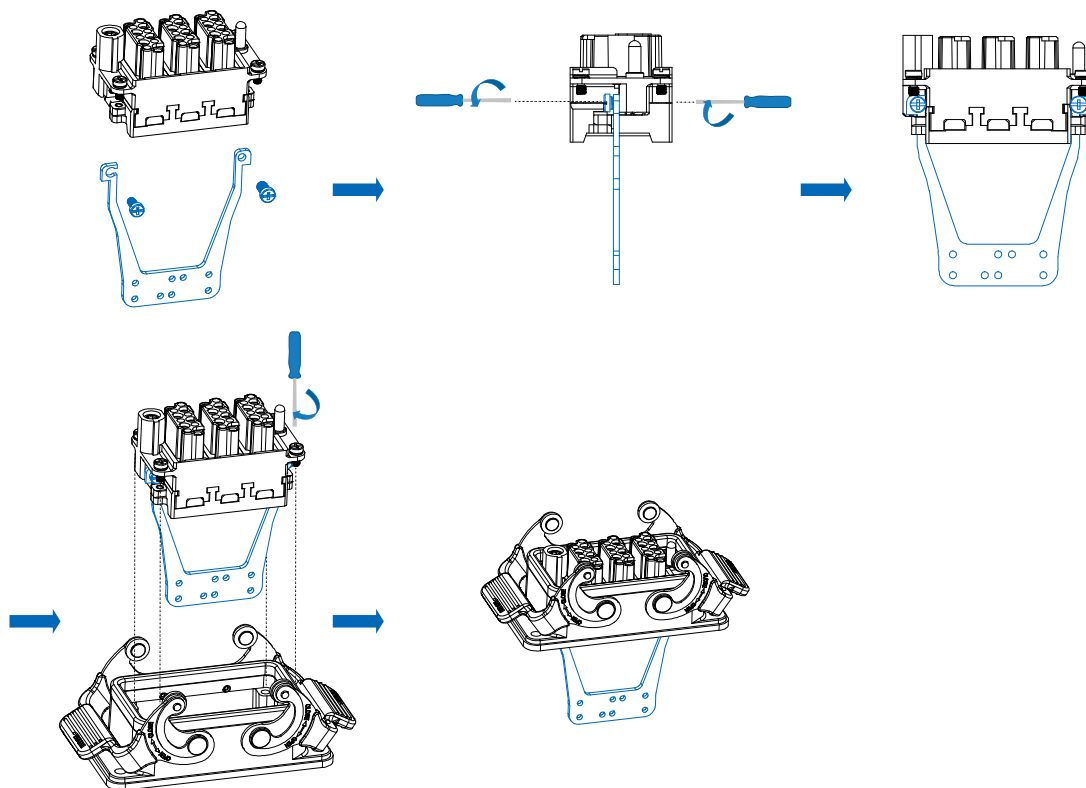

Accessories

Coding system with code pins

Code pin	Designation CODE-M3/S	Order No. 198 002 005 0006
----------	--------------------------	-------------------------------



Modular code pin	Designation MCODE-M3/S	Order No. 198 002 005 0020
------------------	---------------------------	-------------------------------



“/S” -stainless steel

Coding system with guide pins/bushes

Guide bush	Designation GBUSH-M3/S	Order No. 198 002 005 0018
------------	---------------------------	-------------------------------



Guide bush with crown spring	Designation GBUSH-M3/S 3CR	Order No. 198 002 005 0031
------------------------------	-------------------------------	-------------------------------



Guide pin	Designation GPIN-M3/S	Order No. 198 002 005 0017
-----------	--------------------------	-------------------------------



Modular guide bush	Designation MGBUSH-M3/S	Order No. 198 002 005 0023
--------------------	----------------------------	-------------------------------



Modular guide pin	Designation MGPIN-M3/S	Order No. 198 002 005 0022
-------------------	---------------------------	-------------------------------



“/S” -stainless steel

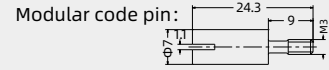
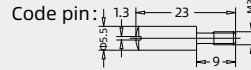

for hoods/housings with one insert/one frame

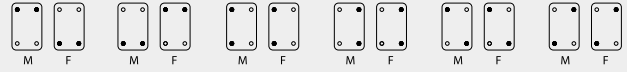

for hoods/housings with two inserts/two frames

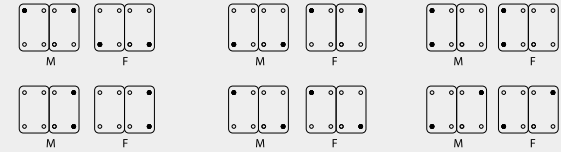

- Code pin
- Normal mounting screw
- M-Male insert
- F-Female insert

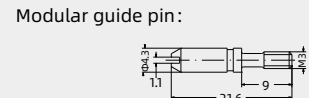
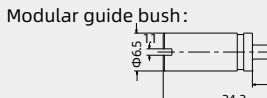
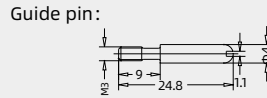
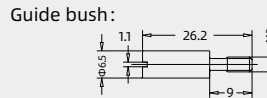

for hoods/housings with one insert/one frame

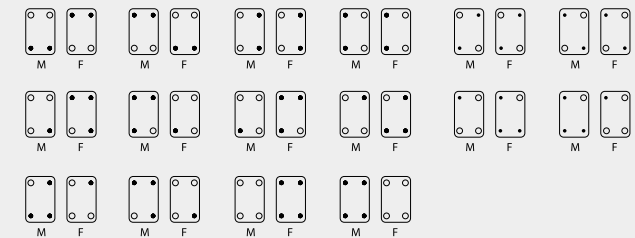

for hoods/housings with two inserts/two frames

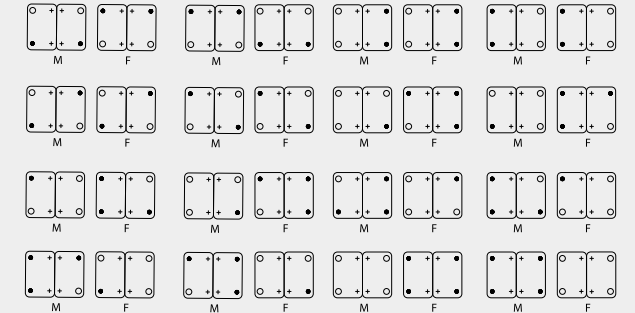

- Guide pin
- Bush
- + Normal mounting screw
- M-Male insert
- F-Female insert

## Accessories

### Coding

#### Code pin



Designation	Order No.
CODE-E	198 002 005 0002

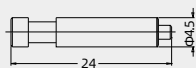

- ① Use of the coding pin prevents incorrect mating to other connectors of the same type.
- ② For HEC, HEE, HQ-005/0, HM-006, HM-008
- ③ The male pin should be omitted from the opposing cavity in the male insert.

#### Code pin



Designation	Order No.
CODE-D	198 002 005 0001

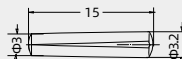

- ① Use of the coding pin prevents incorrect mating to other connectors of the same type.
- ② For HD, HDD, HMD-012, HMDD-017, HQ-7/0, HQ-012/0
- ③ The male pin should be omitted from the opposing cavity in the male insert.

#### Screw pin



Designation	Order No.
GH-M4	904 000 000 0077

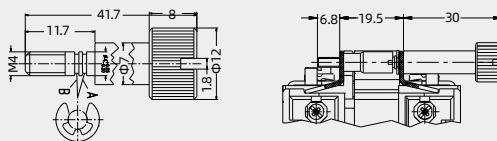

#### Screw bash



Designation	Order No.
GHT-M3	904 000 000 0079

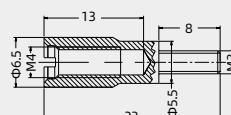

### frame

#### Mounting

##### for H version housings



Size	Designation	Order No.
6B	HP6B-MF	113 006 000 1091
10B	HP10B-MF	113 010 000 1091
16B	HP16B-MF	113 016 000 1091
24B	HP24B-MF	113 024 000 1091

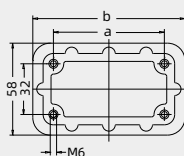

Size	a	b
6B	70	96
10B	83	109
16B	103	129
24B	130	156

#### Docking frame



Size	Designation	Order No.
6B	H6B-ADK	198 002 004 0001
10B	H10B-ADK	198 002 004 0002
16B	H16B-ADK	198 002 004 0003
24B	H24B-ADK	198 002 004 0005

#### Technical characteristics

- Material**
- Docking frame stainless steel
  - Fixing screws steel, zinc-plated
- Pull-in-range**
- x-axis ±1.5mm
  - y-axis ±1.5mm

- Mechanical working life**
- mating cycles ≥500

#### Range of delivery:

- 1 frame
- 4 cheese head shoulder screws to fix mm; for pneumatic contacts max. 26.5 mm

#### Assembly cut out

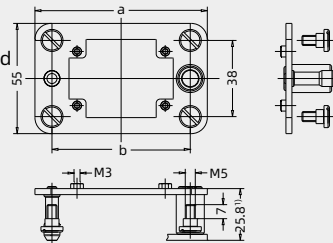

size	a	b	c	d	e
6B	86	69	69	54.5	84
10B	99	82	82	67.5	97
16B	119.5	102.5	102.5	88	117.5
24B	146	129	129	114.5	144

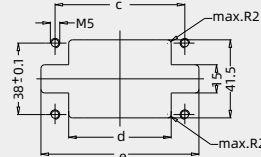

## Accessories

### Cable clamp fitting

#### Straight cable clamp fitting



Designation	Order No.
CCF-T	198 002 003 0021

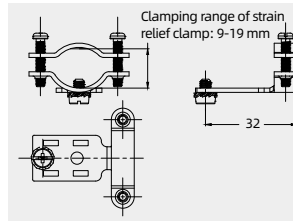

When using inserts without hoods or housings, a cable clamp is needed. The cable clamp is suitable for the following inserts: HDD, HE, HSB, HVE, HVES, HEE series, as well as HK-008/24, HD-040, HD-064 and the opposite end to the PE-termination.

#### Angled cable clamp fitting



Designation	Order No.
CCF-S	198 002 003 0020

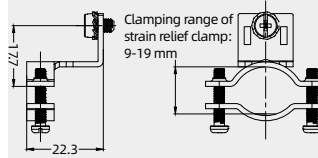

When using inserts without hoods or housings, a cable clamp is needed. The cable clamp is suitable for the following inserts: HDD, HE, HSB, HVE, HVES, HEE series, as well as HK-008/24, HD-040, HD-064 and the opposite end to the PE-termination.

#### Nickel plated multi-grounding number of grounding contacts 3



Designation	Order No.
PE-MGC	198 002 006 0015

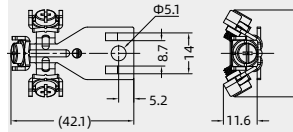

- Number of grounding contacts 3
- Material: copper alloy
- Surface: Nickel plating

Assembly requirements:  
It is suitable for high structure shell, and if the structure is side entry, the fittings are assembled on the side of the non-outlet hole

Adaptable products: HD (type B), HDD, HE, HVE, HEE, HSB, HK (with grounding connecting block structure on both sides) insert series.

### Screw

#### Grounding screw for 3A hoods/housings, With tapered seals



Designation	Order No.
M3*6	904 000 000 0029

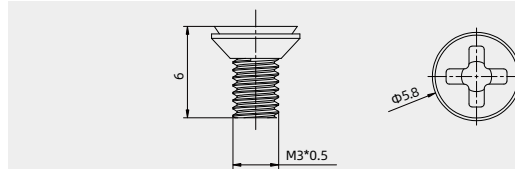

### HE-024 Sealing pad(dust, water, smoke, anti-shock)

#### Protection covers

for 24B Housings, bulkhead mounted (HE-024 inserts)



Technical characteristics  
Material PP+TPE  
Limiting temperatures -40°C ...+90°C  
Wire gauge 0.14-2.5mm<sup>2</sup>  
Wire diameter 1.3-3.6mm  
Degree of protection IP65

Designation	Order No.
24B-F/Pro-hum	903 000 000 0278

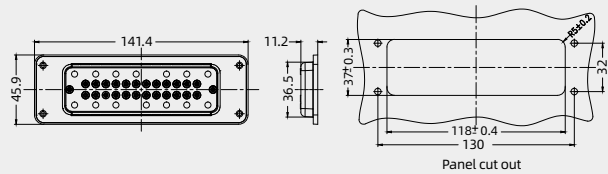

- TPE+PP material durable in use
- Unique hole site structure degree of protection up to IP65



Accessories

Adapter

Hoods/Housings: size 10A, please find the details on page 15-17~15-18.1

D-Sub adapter



Designation	Order No.
APT-10A/DB-d25	198 002 007 0030

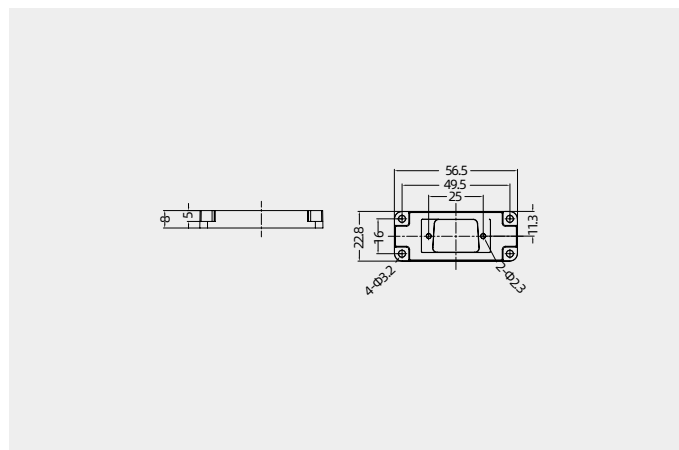

Hexagon bolt



Designation	Order No.
M3x6.2x11-#4-40	104 000 000 0001

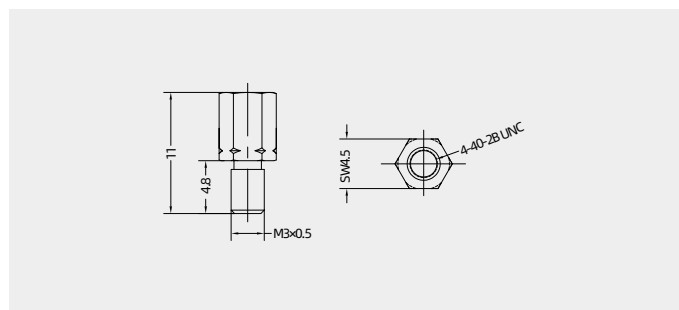

Grounded multiplier copper sheet

PE



Designation	Order No.
PE-8MGC	198 002 001 0011

Material: Cold-rolled sheet  
 Surface: zinc-plated  
 Torsion: The screw loses the protective tightening torque 1.2N.m  
 Assembly requirements: Suitable for BK perforated housing  
 Adaptable products: HD(type B),HDD,HE,H-VE,HEE,HSB,HK(with grounding connecting block structure on both sides) insert series.

A

# Hood&Housing



H



## Rectangular connector-Hoods/Housings Contents



Size	Type	Page
3A	Hoods/Housings(Plastic,Standard,EMC,Corrosion Resistance)	P15-06~P15-16.1
10A	Metal Hoods/Housings	P15-17~P15-18.1
16A	Metal Hoods/Housings	P15-19~P15-20
32A	Metal Hoods/Housings	P15-21~P15-24
6B	Hoods/Housings(Plastic,Metal,Corrosion Resistance )	P15-25~ P15-38.2
10B	Hoods/Housings(Plastic,Metal,suitable for harsh environment,Corrosion Resistance,Pressure Tight )	P15-39~P15-69
16B	Hoods/Housings(Plastic,Metal,suitable for harsh environment,EMC,Corrosion Resistance,Pressure Tight )	P15-70~P15-107.1
24B	Hoods/Housings(Plastic,Metal,suitable for harsh environment,Corrosion Resistance,Pressure Tight )	P15-108~P15-150
32B	Hoods/Housings(Metal,Pressure Tight )	P~P15-159
48B	Hoods/Housings(Metal,Pressure Tight )	P15-160~P15-162
HC	Metal Hoods/Housings	P15-163~P15-168
Thickned seal part	( H series BK housing)	P15-169~P15-170

## Levers for option

Identify	Main material	Description	Designation Example
	Stainless steel+TPR	high-strength locking, device with rubber cover, Suitable for harsh environment (anti-corrosion)	H24B-SF-1L/SC-M25
	PC+Stainless steel	removable locking device, suitable for general industrial environment	H24B-SF-1L/PSE-M25

## Rectangular connector-Hoods/Housings Contents

## the examples of products

	identify	The definition of Corrosion Class, on the basis of ISO12944	The neutral salt spray test ISO7253 /h	The examples of typical environments in temperate climates (for reference only)	models examples
	/480	C3 High	480	The urban and industrial atmospheres, moderate sulfur dioxide pollution, and low salinity coastal areas	W10B-TEH-4B-M32/480
	/720	C4 High	720	The industrial and coastal areas with moderate salinity	W10B-TEH-4B-M32/720
	/1440	C5 High	1440	The industrial areas with high humidity and harsh atmosphere and coastal areas with high salinity	W10B-TEH-4B-M32/1440

\*The metal casings such as the housing and the base of the connector can be corrosive to different degrees. The models in the table are only for the purpose of making the product model naming rules clearer for customers. More models are welcome to consult.

Dear customer:

Thank you very much for your continued trust in our products and your support for our company.

During the course of development, WAIN has always been trying to improve and enrich its products. To meet the customer's need for connectors between IP65 and IP68, we develop brand-new IP67 metal shells. Affected models include 6B、10B、16B、24B、32B、32A (3A、10A、16A and 48B are not included at present) . These new shells can endure harsher environments especially outdoor operating environments, such as tower crane infrastructure、road construction、construction vehicles、outdoor cabinets、mining machinery and so on.

IP67 shells are named W series products, their designations begin with the letter " W ", such as W6B、W10B、W16B、W24B、W32B、W32A. We redesign the appearance、seal flatness and manufacturing technique, while the size remains the same. W series products are compatible with H series products, as well as all standard inserts、modular frames、cable glands and so on.

The differences between W series products and H series products (take 24B for example):

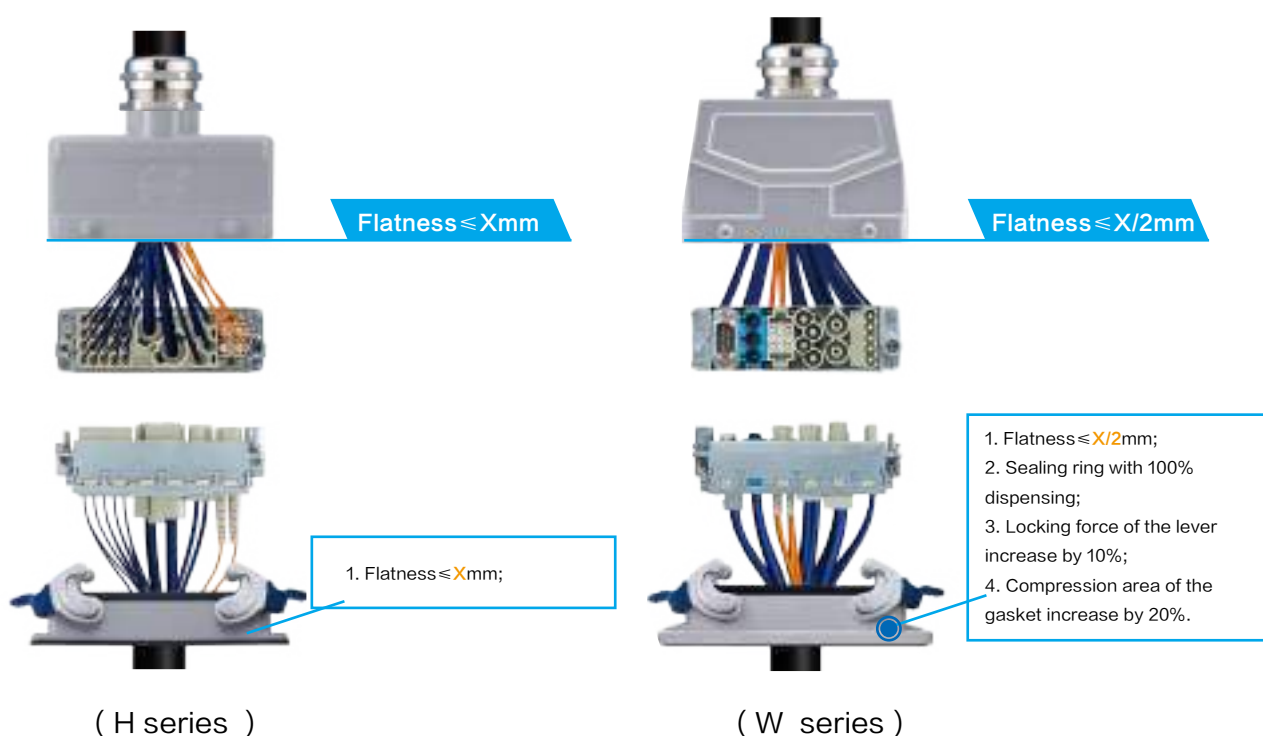

While promoting the W series products, the present H series products are also continued to be supplied, in other words we will supply IP65、IP67、IP68、IP69K products at the same time. ( For specific technical parameters of W series products, please kindly refer to our catalogue). Through redesigning these shells, we wish to demonstrate WAIN's innovative spirit and the ability of independent development. We appreciate your understanding and support in this matter, and we hope that you will like our redesigned shells. We will offer more products and innovations continuously.

Should you have any questions, please do not hesitate to contact us.

Illustration for IP65 or IP67 under different matches between W series shells and H series metal shells  
(take high construction hood+ bulkhead mounted housing for example)

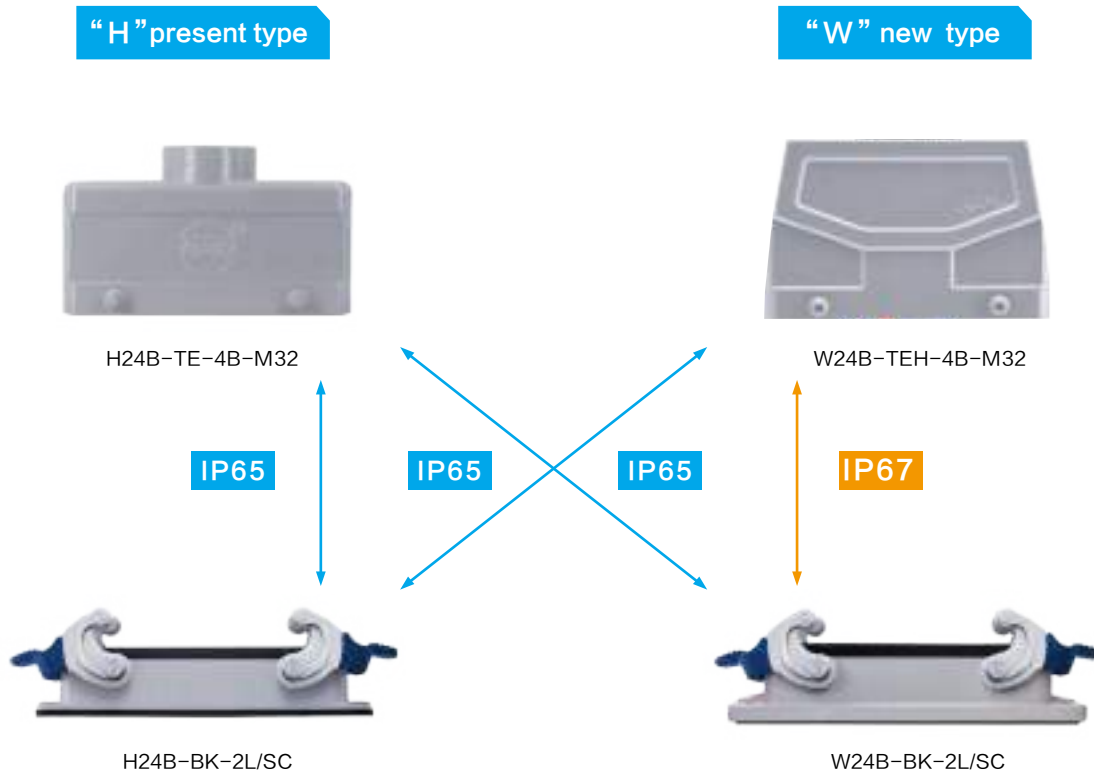

\*For the definition and requirements of IP grade, please kindly refer to IEC 60529-2013

## Technical characteristics

Size 3A Plastic Hoods & Housings IP65	
Material	polycarbonate
Colour	light grey (RAL 7032) black (RAL 9005)
Locking element	
-Lever type	plastic elastic pressing
-Material	polyamide
Hoods/Housings seal	NBR
Limiting temperatures	-40...+125°C
Flammability acc. to UL 94	V0
Degree of protection acc.to DIN EN	
60 529 for coupled connector	IP65

Size 3A Metal Hoods & Housings IP65	
Material	zinc die-cast
Colour	grey
Locking element	
-Lever type	metal elastic pressing
-Material	metal galvanized/ nickel plating
Hoods/Housings seal	NBR
Limiting temperatures	-40...+125°C
Flammability acc. to UL 94	V0
Degree of protection acc.to DIN EN	
60 529 for coupled connector	IP65

3A Pressure tight Hoods & Housings IP68/IP69k	
Surface	Epoxy powder coating
Material	zinc die-cast
Colour	black or grey
Locking element	
-Lever type	screw locking
-Material	stainless steel
Hoods/Housings seal	NBR
Limiting temperatures	-40...+125°C
Flammability acc. to UL 94	V0
Degree of protection acc.to DIN EN	
60 529 for coupled connector	IP68/IP69K

EMC Electromagnetic Compatibility Hoods & Housings IP65	
Material	zinc die-cast(3A) aluminium die-cast(Type B)
Surface	electrical conductive
Locking element	
-Lever type	metal elastic pressing/screw locking
-Material	see15-02
Hoods/Housings seal	NBR
Limiting temperatures	-40...+125°C
Flammability acc. to UL 94	V0
Degree of protection acc.to DIN EN	
60 529 for coupled connector	H version IP65 / W version IP67

HC Metal Hoods & Housings IP65	
Surface	Epoxy powder coating/nickeling
Colour	zinc die-cast
Locking element	black/brushed nickel
Locking element	
-Lever type	metal elastic pressing
-Material	stainless steel
Hoods/Housings seal	NBR
Limiting temperatures	-40...+125°C
Flammability acc. to UL 94	V0
Degree of protection acc.to DIN EN	
60 529 for coupled connector	IP65

Plastic Hoods & Housings IP65	
Material	polyamide
Colour	RAL 9005 (black)
Locking element	
-Lever type	plastic elastic pressing
-Material	polyamide
Hoods/Housings seal	NBR
Limiting temperatures	-40...+125°C
Flammability acc. to UL 94	V0
Degree of protection acc.to DIN EN	
60 529 for coupled connector	IP65

Metal Hoods & Housings IP65	
Material	aluminium die-cast
Colour	grey
Locking element	
-Lever type	metal elastic pressing
-Material	see P15-02
Hoods/Housings seal	NBR
Limiting temperatures	-40...+125°C
Flammability acc. to UL 94	V0
Degree of protection acc.to DIN EN	
60 529 for coupled connector	H version IP65 / W version IP67

Hoods/Housings for higher environmental requirements IP65	
Material	zinc die-cast(3A), aluminium die-cast,
Colour	RAL 9005 (black)
Surface- Top coat	epoxy powder paint
Locking element	
-Lever type	metal elastic pressing
-Material	stainless steel
Hoods/Housings seal	FPM
Limiting temperatures	-40...+125°C
Flammability acc. to UL 94	V0
Degree of protection acc.to DIN EN	
60 529 for coupled connector	H version IP65 / W version IP67

Pressure tight Hoods & Housings IP68/IP69k	
Material	aluminium die-cast, corrosion resistant
Colour	black or grey
Locking element	
-Lever type	screw locking
-Material	stainless steel
Hoods/Housings seal	NBR
Limiting temperatures	-40...+125°C
Flammability acc. to UL 94	V0
Degree of protection acc.to DIN EN	
60 529 for coupled connector	IP68/IP69K

HC Plastic Hoods & Housings IP65	
Material	polycarbonate
Colour	RAL 9005 (black)
Locking element	
-Lever type	plastic elastic pressing
-Material	polyamide
Hoods/Housings seal	NBR
Limiting temperatures	-40...+125°C
Flammability acc. to UL 94	V0
Degree of protection acc.to DIN EN	
60 529 for coupled connector	IP65

## 3A Plastic hoods/housings

Degree of protection: IP65

## Hoods, side entry



Thread	Designation	Order No.
M20	H3A.P-SE-2B-M20	118 003 510 1002
PG11	H3A.P-SE-2B-PG11	118 003 510 1008

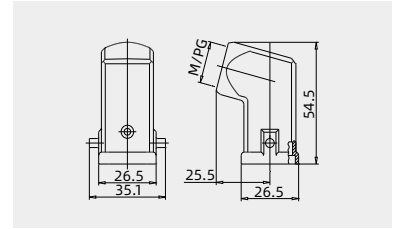

## Hoods, top entry



Thread	Designation	Order No.
M20	H3A.P-TE-2B-M20	118 003 410 1002
PG11	H3A.P-TE-2B-PG11	118 003 410 1008

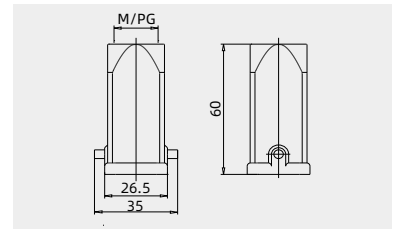

## Hoods, top entry



Thread	Designation	Order No.
M25	H3A.P-TE-2B-M25	118 003 410 1512
PG16	H3A.P-TE-2B-PG16	118 003 410 1513

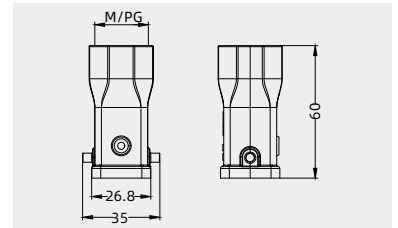

## Hoods, top entry



Thread	Designation	Order No.
OTr30	H3A.P-TE-2B-OTr30(D7-12)	118 003 410 1516
OTr30	H3A.P-TE-2B-OTr30(D11-17)	118 003 410 1517

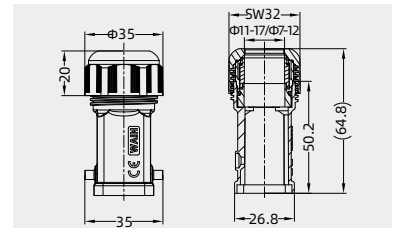



## 3A Plastic hoods/housings

Degree of protection: IP65

## Bulkhead mounted housings



Thread	Designation	Order No.
---	H3A.P-BK-1L	118 003 327 1001

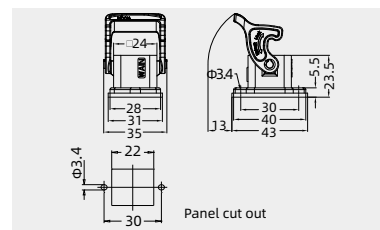

## Bulkhead mounted housings



Thread	Designation	Order No.
---	H3A.P-BK-1L-SE	118 003 927 1001

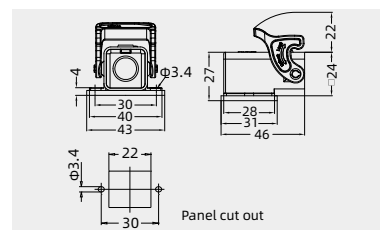

## Surface mounted housings



Thread	Designation	Order No.
M20	H3A.P-SF-1L-M20	118 003 227 1002
PG11	H3A.P-SF-1L-PG11	118 003 227 1008

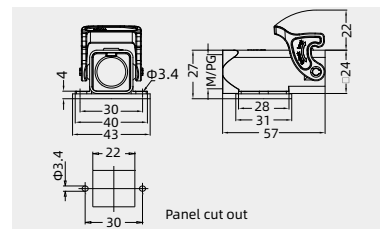

## Housings, cable to cable



Thread	Designation	Order No.
M20	H3A.P-CCT-1L-M20	118 003 727 1002
PG11	H3A.P-CCT-1L-PG11	118 003 727 1008

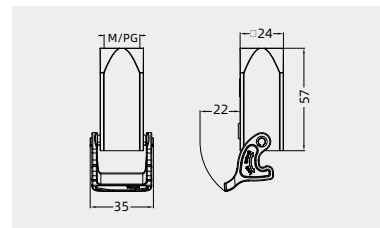

## Protection covers



Connect way	Designation	Order No.
	H3A-CV-1L/1M (for male insert)	110 003 027 8001
	H3A-CV-1L/1F (for female insert)	110 003 027 8002

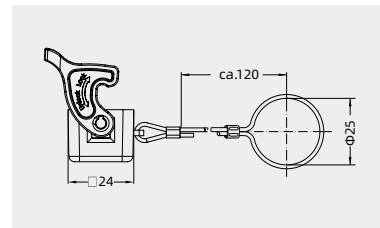

## Protection covers, cable to cable



Connect way	Designation	Order No.
	H3A-CV-2B/1M (for male insert)	110 003 010 8001
	H3A-CV-2B/2M (for male insert)	110 003 010 8004
	H3A-CV-2B/1F (for female insert)	110 003 010 8002
	H3A-CV-2B/2F (for female insert)	110 003 010 8005

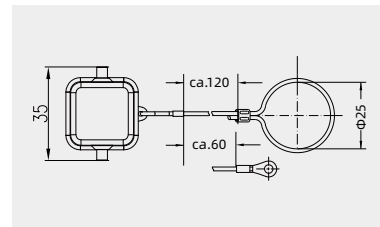

## 3A Plastic hoods/housings

Degree of protection: IP65

## Hoods, side entry



Thread	Designation	Order No.
M20	H3A.P-SE-2B-M20 2B	118 003 510 1506
PG11	H3A.P-SE-2B-PG11 2B	118 003 510 1507

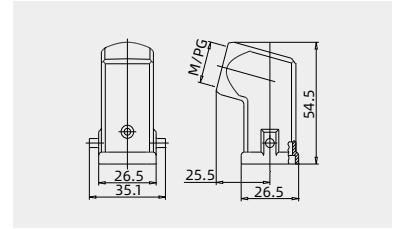

## Hoods, top entry



Thread	Designation	Order No.
M20	H3A.P-TE-2B-M20 2B	118 003 410 1511
PG11	H3A.P-TE-2B-PG11 2B	118 003 410 1514

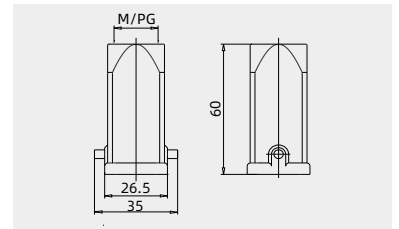

3A Plastic hoods/housings

Degree of protection: IP65

Bulkhead mounted housings



Thread	Designation	Order No.
---	H3A.P-BK-1L 2B	118 003 320 1002

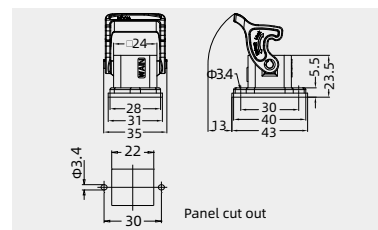

Bulkhead mounted housings



Thread	Designation	Order No.
---	H3A.P-BK-1L-SE 2B	118 003 320 1003

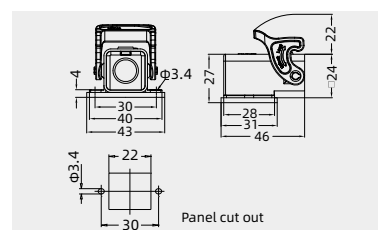

Surface mounted housings



Thread	Designation	Order No.
M20	H3A.P-SF-1L-M20 2B	118 003 220 1002
PG11	H3A.P-SF-1L-PG11 2B	118 003 220 1003

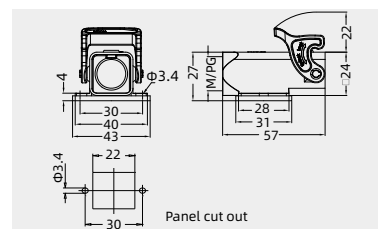

Housings, cable to cable



Thread	Designation	Order No.
M20	H3A.P-CCT-1L-M20 2B	118 003 720 1001
PG11	H3A.P-CCT-1L-PG11 2B	118 003 720 1003

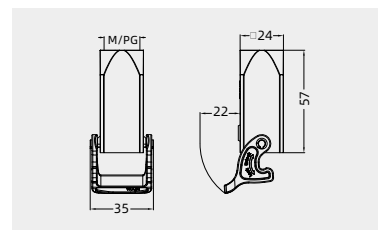

Protection covers



Connect way	Designation	Order No.
	H3A-CV-1L/1M 2B(for male insert)	110 003 020 8002
	H3A-CV-1L/1F 2B(for female insert)	110 003 020 8003

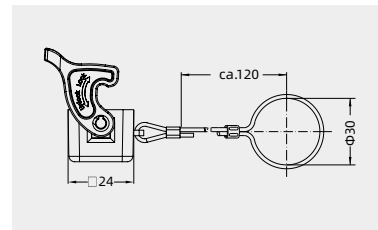

Protection covers, cable to cable



Connect way	Designation	Order No.
	H3A-CV-2B/1M 2B(for male insert)	110 003 010 8511
	H3A-CV-2B/2M 2B(for male insert)	110 003 010 8512
	H3A-CV-2B/1F 2B (for female insert)	110 003 010 8513
	H3A-CV-2B/2F 2B (for female insert)	110 003 010 8514

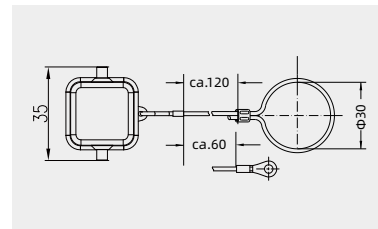

## 3A Metal hoods/housings

Degree of protection: IP65

## Hoods, side entry



Thread	Designation	Order No.
M20	H3A-SE-2B-M20	110 003 510 1002
PG11	H3A-SE-2B-PG11	110 003 510 1008

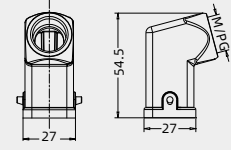

## Hoods, side entry



Thread	Designation	Order No.
M25	H3A-SEH-2B-M25	110 003 510 5001
PG16	H3A-SEH-2B-PG16	110 003 510 5002

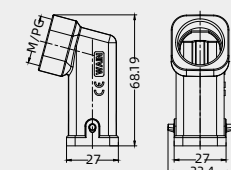

## Hoods, side entry ,high construction



Thread	Designation	Order No.
M20	H3A-SEHC-2B-M20	112 003 510 1001
PG11	H3A-SEHC-2B-PG11	110 003 510 1519

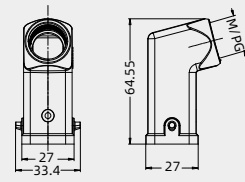

## Hoods, top entry



Thread	Designation	Order No.
M20	H3A-TE-2B-M20	110 003 410 1002
PG11	H3A-TE-2B-PG11	110 003 410 1008
PG13.5	H3A-TE-2B-PG13.5	110 003 410 1009

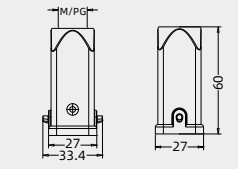

## Hoods, top entry



Thread	Designation	Order No.
M25	H3A-TE-2B-M25	110 003 410 1004

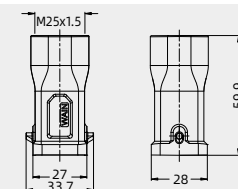

## Bulkhead mounted housings



Thread	Designation	Order No.
---	H3A-BK-1L/W	110 003 324 1001

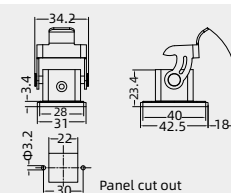

## Bulkhead mounted housings



Thread	Designation	Order No.
---	H3A-BK-1L/W-MCV/M(for male insert)	110 003 364 1101
---	H3A-BK-1L/W-MCV/F(for female insert)	110 003 364 1102

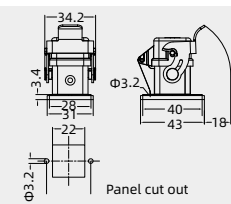

## 3A Metal hoods/housings

The mounting hole of the mounting cabinet can be temporarily sealed.  
Applicable to the installation hole which has been opened, The case where the connector is not installed

Degree of protection: IP65

BK hole cover plate

Thread	Designation	Order No.
---	3A-BK/MCV	110 003 300 8001

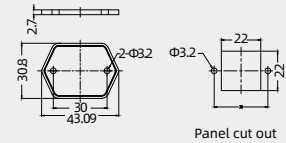

## 3A Metal hoods/housings

Degree of protection: IP65

## Bulkhead mounted housings



Thread	Designation	Order No.
---	H3A-BK-1L/W-SE	110 003 924 1001

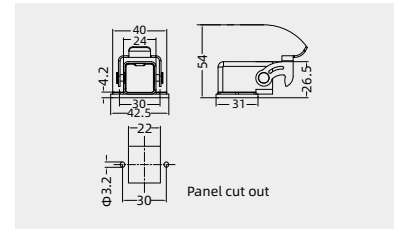

## Housings



Thread	Designation	Order No.
	Bulkhead mounted	
PG11	H3A-SF/BK-1L/W-PG11	110 003 224 1108
	Surface mounted	
M20	H3A-SF-1L/W-M20	110 003 224 1002
PG11	H3A-SF-1L/W-PG11	110 003 224 1008
PG13.5	H3A-SF-1L/W-PG13.5	110 003 224 1009

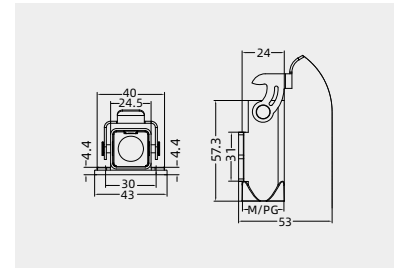

## Housings



Thread	Designation	Order No.
M20	H3A-SF-1L/W-M20-D39	101 000 099 0177

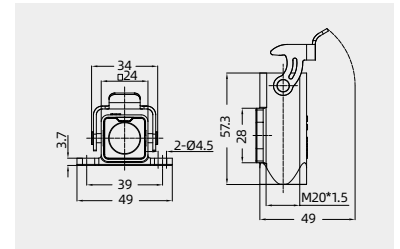

Different installation holes

## Housings, cable to cable



Thread	Designation	Order No.
M20	H3A-CCT-1L/W-M20	110 003 724 1002
PG11	H3A-CCT-1L/W-PG11	110 003 724 1008

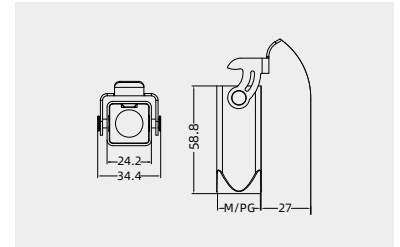

## 3A Metal hoods/housings

Degree of protection: IP65

Housings, cable to cable



Thread	Designation	Order No.
M25	H3A-CCT-1L/W-M25	110 003 724 1003

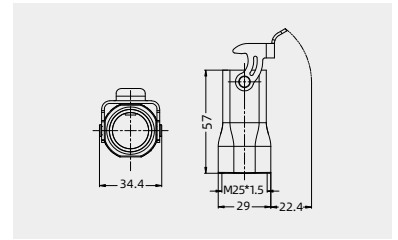

Housings, cable to cable  
Under-shell through-board  
installation



Thread	Designation	Order No.
M20	H3A-CCT/BK-IL/W-M20	110 003 724 1514

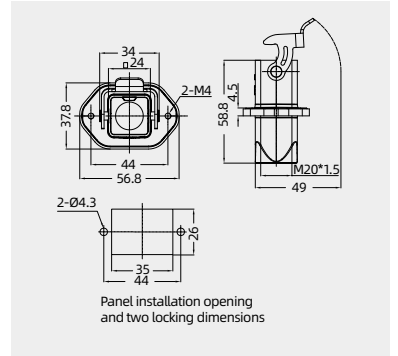

Hoods, top entry,with cable gland



Thread	Designation	Order No.
M25	H3A-TE-2B-OM25(D6-12)	110 003 410 1003
M25	H3A-TE-2B-OM25(D11-17)	110 003 410 1103

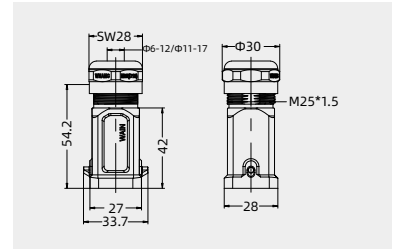

## 3A Metal hoods/housings

Degree of protection: IP65

## Hoods, top entry



Thread	Designation	Order No.
---	H3A-TE-2B-1L/S-M20	110 003 265 8002

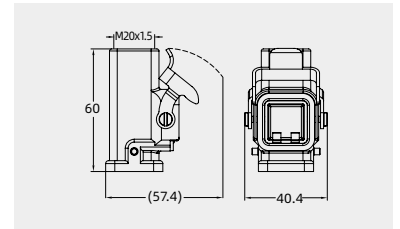

## Surface mounted housings



Thread	Designation	Order No.
M20	H3A-SF-1L/S-M20-MCV/F (for female insert)	110 003 265 1502

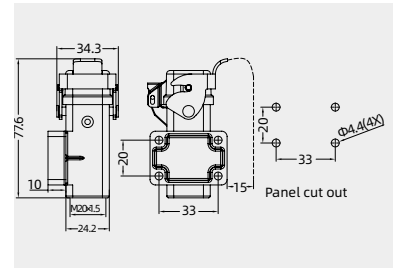

## Surface mounted housings with PCB



Thread	Designation	Order No.
M20	H3A-SF-1L/S-M20-MCV/PC(1、2) (for female insert) <sup>1)</sup>	110 003 265 8001

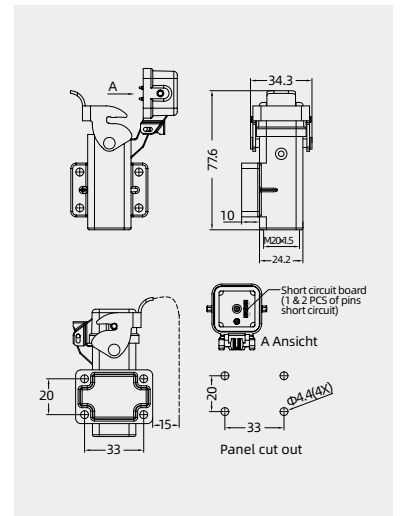

1). Only suitable for HA-004 series.



## 3A Metal hoods/housings (EMC)

Degree of protection: IP65

## Hoods, side entry



Thread	Designation	Order No.
M20	EMC.H3A-SE-2B-M20	110 603 510 1002
PG11	EMC.H3A-SE-2B-PG11	110 603 510 1008

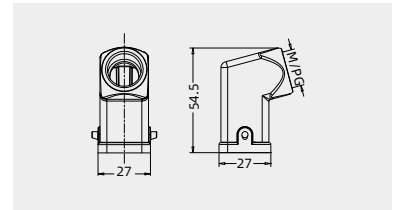

## Hoods, top entry



Thread	Designation	Order No.
M20	EMC.H3A-TE-2B-M20	110 603 410 1002
PG11	EMC.H3A-TE-2B-PG11	110 603 410 1008

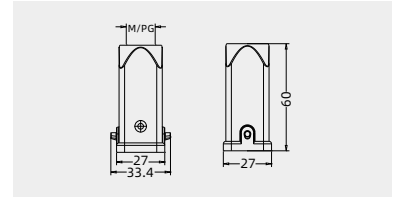

## Bulkhead mounted housings



Thread	Designation	Order No.
---	EMCD.H3A-BK-1L/W	110 603 324 1101

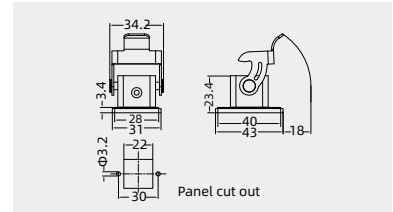

## Bulkhead mounted housings



Thread	Designation	Order No.
---	EMCD.H3A-BK-1L/W-MCV/M(for male insert)	110 603 364 1101
---	EMCD.H3A-BK-1L/W-MCV/F(for female insert)	110 603 364 1102

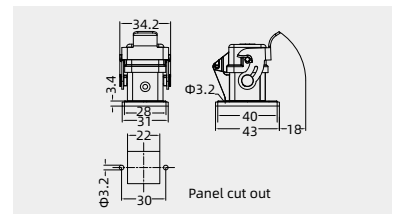

## Bulkhead mounted housings



Thread	Designation	Order No.
---	EMCD.H3A-BK-1L/W-SE	110 603 924 1101

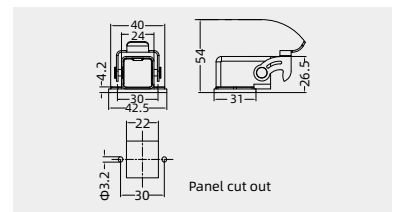

## Surface mounted housings



Thread	Designation	Order No.
M20	EMC.H3A-SF-1L/W-M20	110 603 224 1002
PG11	EMC.H3A-SF-1L/W-PG11	110 603 224 1008

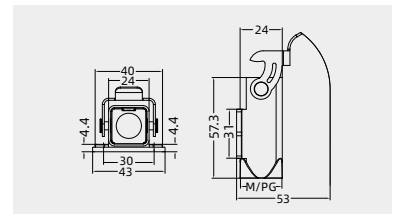

## Housings, cable to cable



Thread	Designation	Order No.
M20	EMC.H3A-CCT-1L/W-M20	110 603 724 1002
PG11	EMC.H3A-CCT-1L/W-PG11	110 603 724 1008

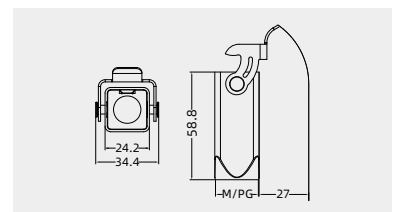

## 3A Metal hoods/housings (EMC)

Degree of protection: IP65

Housings, cable to cable,  
plate installation

Thread	Designation	Order No.
M20	EMC.H3A-CCT/BK-1L/W-M20	110 603 724 1500

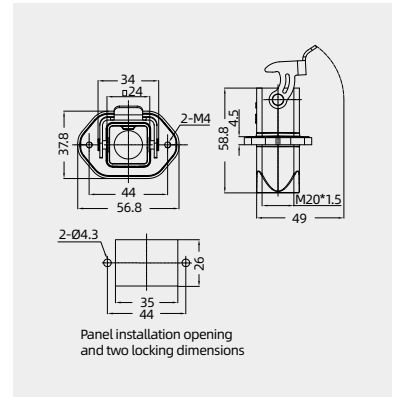

## 3A Metal hoods/housings (EMC)

Degree of protection: IP65

EMC

Hoods, top entry, with cable gland



Thread	Designation	Order No.
M25	EMC.H3A-TE-2B-OM25(D6-12)	110 603 410 1003
M25	EMC.H3A-TE-2B-OM25(D11-17)	110 603 410 1203

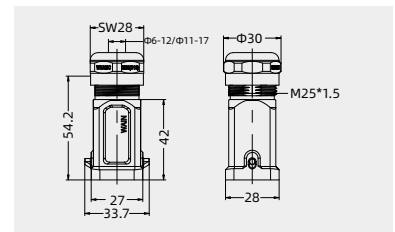

Degree of protection: IP65

Protection covers



Connect way	Designation	Order No.
	H3A-MCV-1L/1M (for male insert)	110 003 024 8101
	H3A-MCV-1L/1F (for female insert)	110 003 024 8102

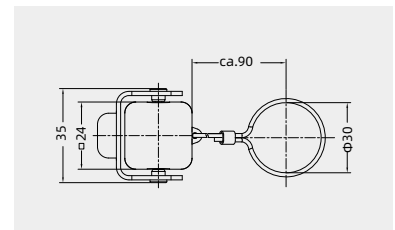

Protection covers



Connect way	Designation	Order No.
	H3A-MCV-2B/1M (for male insert)	110 003 010 8101
	H3A-MCV-2B/2M (for male insert)	110 003 010 8104
	H3A-MCV-2B/1F (for female insert)	110 003 010 8102
	H3A-MCV-2B/2F (for female insert)	110 003 010 8105

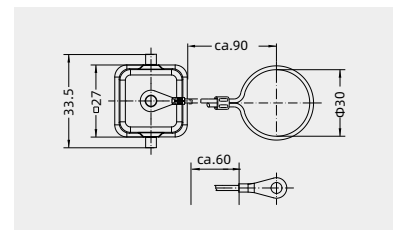

Degree of protection: IP20

Protection covers  
(for Housings), plastic

Connect way	Designation	Order No.
	H3A-CV/1C	113 003 900 8501

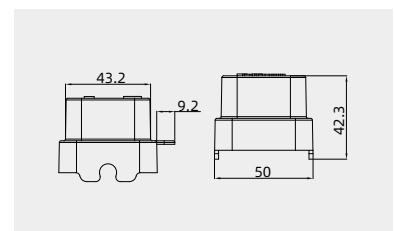

## 3A Metal hoods/housings -Suitable for harsh environment(anti-corrosion)

Degree of protection: IP65

### Hoods, side entry



Thread	Designation	Order No.
M20	H3A-MSE-2B-M20	112 003 510 1002
PG11	H3A-MSE-2B-PG11	112 003 510 1008

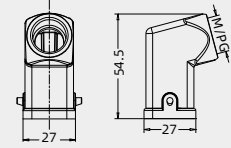

### Hoods, top entry



Thread	Designation	Order No.
M20	H3A-MTE-2B-M20	112 003 410 1002
PG11	H3A-MTE-2B-PG11	112 003 410 1008

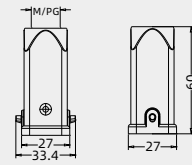

### Bulkhead mounted housings



Thread	Designation	Order No.
---	H3A-MBK-1L/S	112 003 325 1001

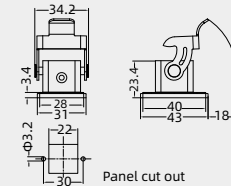

### Bulkhead mounted housings



Thread	Designation	Order No.
---	H3A-MBK-1L/S-SE	112 003 925 1001

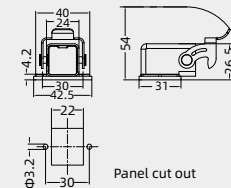

### Surface mounted housings



Thread	Designation	Order No.
M20	H3A-MSF-1L/S-M20	112 003 225 1002
PG11	H3A-MSF-1L/S-PG11	112 003 225 1008

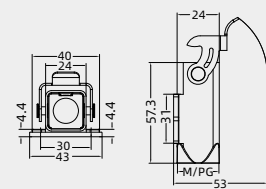

### Housings, cable to cable



Thread	Designation	Order No.
M20	H3A-MCCT-1L/S-M20	112 003 725 1002
PG11	H3A-MCCT-1L/S-PG11	112 003 725 1008

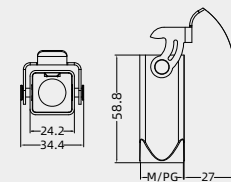



## 3A Metal hoods/housings -Suitable for harsh environment(anti-corrosion)

Degree of protection: IP65

### Protection covers





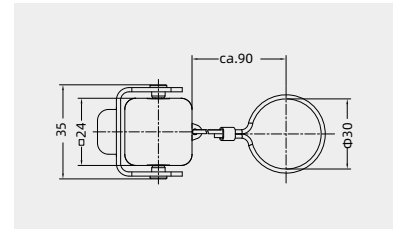

Connect way	Designation	Order No.
	H3A-MMCV-1L/1M (for male insert)	112 003 025 8001
	H3A-MMCV-1L/1F (for female insert)	112 003 025 8002



### Protection covers



Connect way	Designation	Order No.
	H3A-MMCV-2B/1M (for male insert)	112 003 010 8001
	H3A-MMCV-2B/1F (for female insert)	112 003 010 8002
	H3A-MMCV-2B/2M (for male insert)	112 003 010 8003
	H3A-MMCV-2B/2F (for female insert)	112 003 010 8004

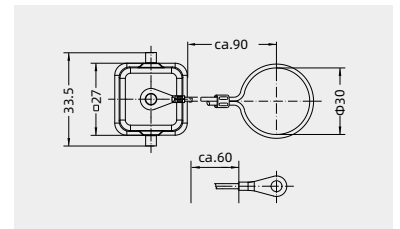

### Hoods, side entry



Thread	Designation	Order No.
M20	H3A-MSE2/S-2B/S-M20	112 003 515 1002

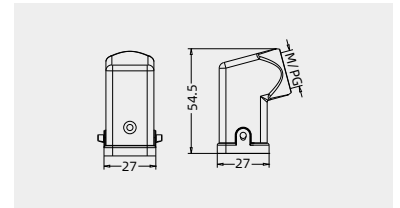

### Bulkhead mounted housings



Thread	Designation	Order No.
---	H3A-MBK-1L/S-MMCV/S/S	112 003 365 1103

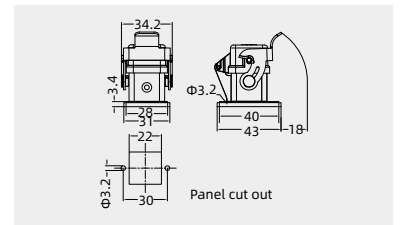

3A Pressure tight hoods/housings

Epoxy powder coating  
Degree of protection: IP68/IP69K

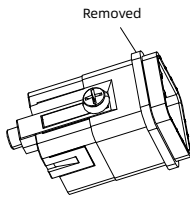

Note: Before installation, if there is a square seal ring on the used insert, the seal ring shall be removed before installation. For more details, please contact us.

H version

Hoods, top entry



Thread	Designation	Order No.
	Epoxy powder coating · Screw locking	
M20	HP3A/H-TE-2S-M20	113 003 420 1002
PG13.5	HP3A/H-TE-2S-PG13.5	113 003 420 1009
	Epoxy powder coating · Toggle locking	
M20	HP3A/H-TE-2T-M20	113 003 440 1002
PG13.5	HP3A/H-TE-2T-PG13.5	113 003 440 1009

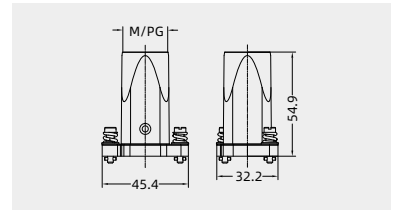

Bulkhead mounted housings\*



Thread	Designation	Order No.
	Epoxy powder coating · Screw locking	
---	HP3A/H-BK-2H	113 003 320 1001
	Epoxy powder coating · Toggle locking	
---	HP3A/H-BK-2T	113 003 340 1001

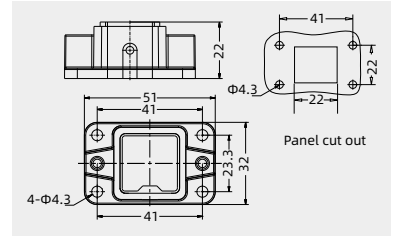

Adaptor for Housings



Thread	Designation	Order No.
	Epoxy powder coating	
---	HP3A/H-BK-SE	113 003 900 1001

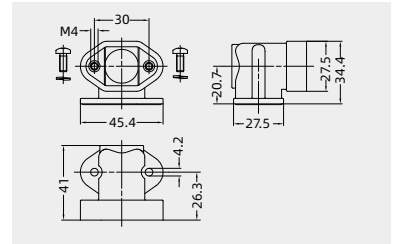

Surface mounted housings



Thread	Designation	Order No.
	Epoxy powder coating · Screw locking	
M20	HP3A/H-SF-2H-M20	113 003 220 1002
PG13.5	HP3A/H-SF-2H-PG13.5	113 003 220 1009

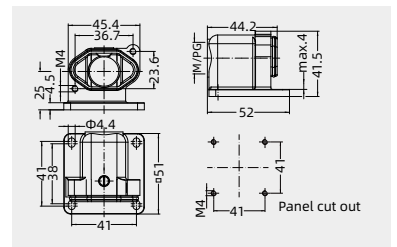

Bulkhead mounted housings



Thread	Designation	Order No.
	Epoxy powder coating · Screw locking	
---	HP3A/H-SF-2H	113 003 220 1001

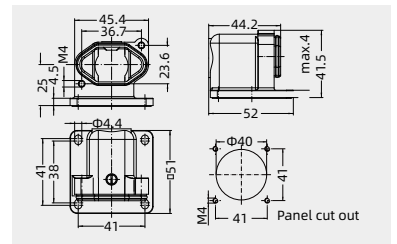

3A Pressure tight hoods/housings

Epoxy powder coating  
Degree of protection: IP68/IP69K

H version

Hoods, top entry, high construction



Thread	Designation	Order No.
	Epoxy powder coating · Screw locking	
M25	HP3A/H-TEH-2S-M25	113 003 420 5003
	Epoxy powder coating · Toggle locking	
M25	HP3A/H-TEH-2T-M25	113 003 440 5003

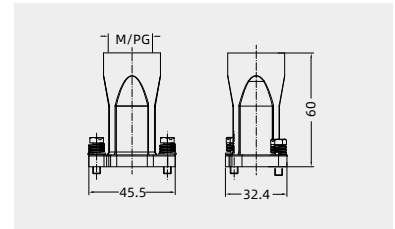

Protection covers, for housings



Connect way	Designation	Order No.
	Epoxy powder coating · Screw locking	
---	HP3A/H-MCV-2S	113 003 020 8103
	HP3A/H-MCV-2S/2S	113 003 020 8102
	Epoxy powder coating · Toggle locking	
---	HP3A/H-MCV-2T	113 003 040 8103
	HP3A/H-MCV-2T/2S	113 003 040 8102

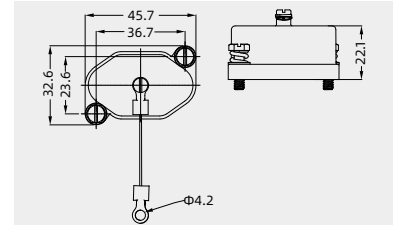

Protection covers, for housings(IP5X)



Connect way	Designation	Order No.
---	HP3A/H-CV/C	113 003 900 8001

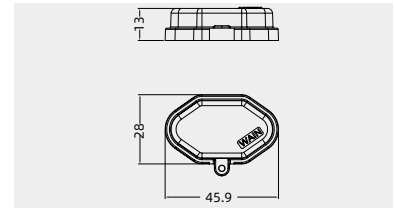

Degree of protection: IP68/IP69K

W version

Hoods, top entry



Thread	Designation	Order No.
M20	HP3A-TE-2S-M20	115 003 420 1002
PG11	HP3A-TE-2S-PG11	115 003 420 1008

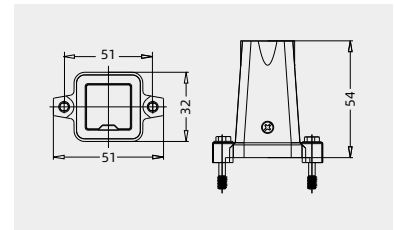

Bulkhead mounted housings



Thread	Designation	Order No.
---	HP3A-BK-2H	115 003 320 1001

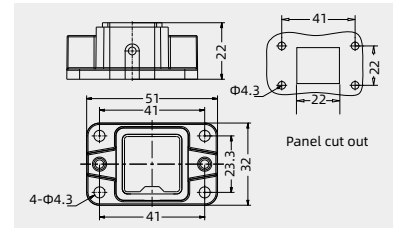

## 3A Pressure tight hoods/housings

Epoxy powder coating

Degree of protection: IP68/IP69K

H version

Hoods, side entry, high construction



Thread	Designation	Order No.
	Epoxy powder coating · Screw locking	
M20	HP3A/H-SEH-2S-M20	113 003 520 5002
M25	HP3A/H-SEH-2S-M25	113 003 520 5001
	Epoxy powder coating · Toggle locking	
M20	HP3A/H-SEH-2T-M20	113 003 540 5002
M25	HP3A/H-SEH-2T-M25	113 003 540 5001

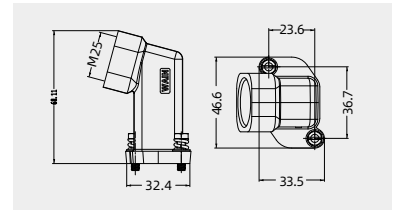



## 10A Metal hoods/housings

Degree of protection: IP65

## Hoods, side entry



Thread	Designation	Order No.
M20	H10A-SE-2B-M20	110 010 510 1002
PG16	H10A-SE-2B-PG16	110 010 510 1010

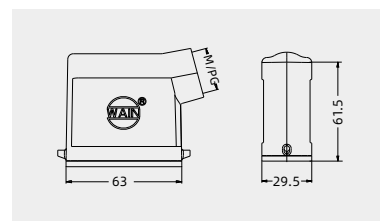

## Hoods, side entry, high construction



Thread	Designation	Order No.
M25	H10A-SEH-2B-M25	110 010 510 5003
PG16	H10A-SEH-2B-PG16	110 010 510 5010
PG21	H10A-SEH-2B-PG21	110 010 510 5011

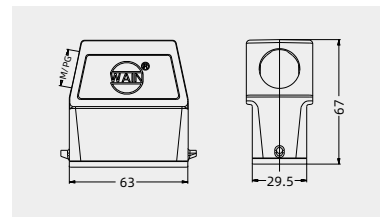

## Hoods, top entry



Thread	Designation	Order No.
M20	H10A-TE-2B-M20	110 010 410 1002
PG13.5	H10A-TE-2B-PG13.5	110 010 410 1009

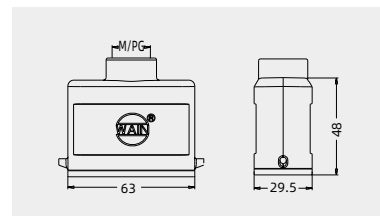

## Hoods, top entry, high construction



Thread	Designation	Order No.
M25	H10A-TEH-2B-M25	110 010 410 5003
PG16	H10A-TEH-2B-PG16	110 010 410 5010
PG21	H10A-TEH-2B-PG21	110 010 410 5011

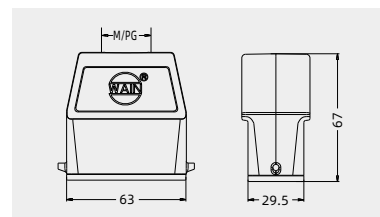

## Housings, cable to cable



Thread	Designation	Order No.
M20	H10A-CCT-1L/SC-M20	110 010 721 1002
PG13.5	H10A-CCT-1L/SC-PG13.5	110 010 721 1009
PG16	H10A-CCT-1L/SC-PG16	110 010 721 1010

Please refer to page 15-02 for choosing proper model of lock.

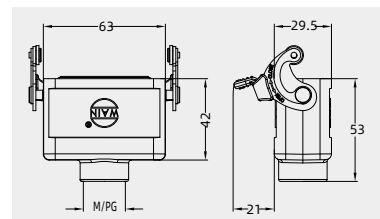

## Housings, cable to cable ,high construction



Thread	Designation	Order No.
M25	H10A-CCTH-1L/SC-M25	110 010 721 5003
PG16	H10A-CCTH-1L/SC-PG16	110 010 721 5010
PG21	H10A-CCTH-1L/SC-PG21	110 010 721 5011

Please refer to page 15-02 for choosing proper model of lock.

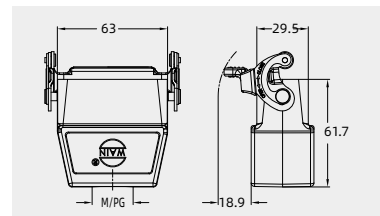

## 10A Metal hoods/housings

Degree of protection: IP65

## Bulkhead mounted housings



Thread	Designation	Order No.
---	H10A-BK-1L/SC	110 010 321 1001
---	with plastic cover	
---	H10A-BK-1L/SC-CV	110 010 361 1001
---	with metal cover	
---	H10A-BK-1L/SC-MCV	110 010 361 1101

Please refer to page 15-02 for choosing proper model of lock.

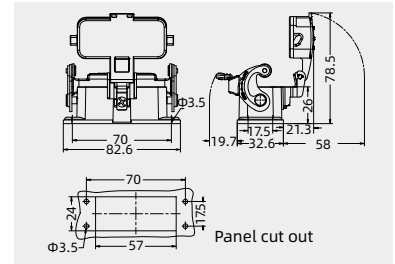

## Surface mounted housings



Thread	Designation	Order No.
M20	H10A-SF-1L/SC-M20	110 010 221 1002
2M20	H10A-SF-1L/SC-2M20	110 010 221 1022
M25	H10A-SF-1L/SC-M25	110 010 221 1003
PG16	H10A-SF-1L/SC-PG16	110 010 221 1010
2PG16	H10A-SF-1L/SC-2PG16	110 010 221 1030
PG21	H10A-SF-1L/SC-PG21	110 010 221 1011

	with plastic cover	
M20	H10A-SF-1L/SC-CV-M20	110 010 261 1002
2M20	H10A-SF-1L/SC-CV-2M20	110 010 261 1022
M25	H10A-SF-1L/SC-CV-M25	110 010 261 1003
PG16	H10A-SF-1L/SC-CV-PG16	110 010 261 1010
2PG16	H10A-SF-1L/SC-CV-2PG16	110 010 261 1030
PG21	H10A-SF-1L/SC-CV-PG21	110 010 261 1011

	with metal cover	
M20	H10A-SF-1L/SC-MCV-M20	110 010 261 1102
2M20	H10A-SF-1L/SC-MCV-2M20	110 010 261 1122
M25	H10A-SF-1L/SC-MCV-M25	110 010 261 1103
PG16	H10A-SF-1L/SC-MCV-PG16	110 010 261 1110
2PG16	H10A-SF-1L/SC-MCV-2PG16	110 010 261 1130
PG21	H10A-SF-1L/SC-MCV-PG21	110 010 261 1111

Please refer to page 15-02 for choosing proper model of lock.

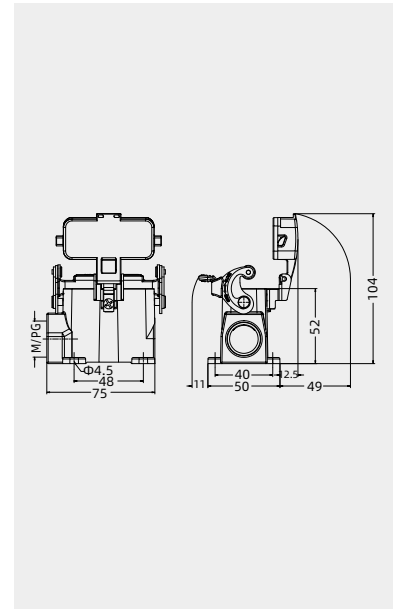

## Protection covers



Connect way	Applications	Designation	Order No.
	for hoods	H10A-MCV-1L/SC.1	110 010 021 8101

Please refer to page 15-02 for choosing proper model of lock.

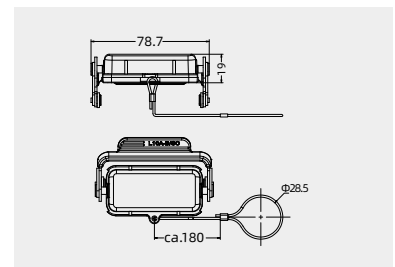

## Protection covers



Connect way	Applications	Designation	Order No.
	for housings	H10A-MCV-2B/1S	110 010 010 8101
	for housings	H10A-MCV-2B/2S	110 010 010 8102

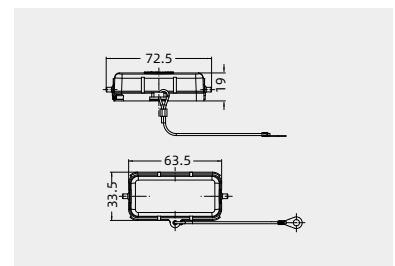

# 10A Plastic hoods/housings

Degree of protection: IP65

Hoods, side entry, high construction



Thread	Designation	Order No.
M25	H10A.P-SEH-2B-M25	118 010 510 5001

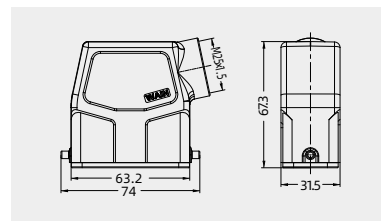

Bulkhead mounted housings



Thread	Designation	Order No.
---	H10A.P-BK-1L	118 010 320 1001

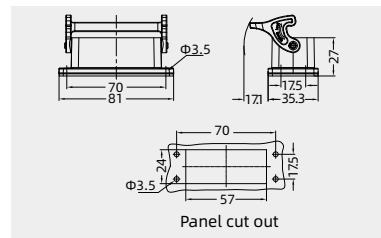

## 16A Metal hoods/housings

Degree of protection: IP65

## Hoods, side entry



Thread	Designation	Order No.
M20	H16A-SE-2B-M20	110 016 510 1002
PG16	H16A-SE-2B-PG16	110 016 510 1010

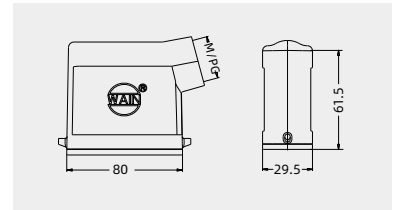

## Hoods, side entry, high construction



Thread	Designation	Order No.
M25	H16A-SEH-2B-M25	110 016 510 5003
PG16	H16A-SEH-2B-PG16	110 016 510 5010
PG21	H16A-SEH-2B-PG21	110 016 510 5011

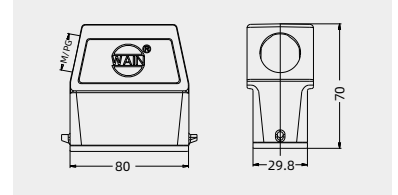

## Hoods, top entry



Thread	Designation	Order No.
M20	H16A-TE-2B-M20	110 016 410 1002
PG16	H16A-TE-2B-PG16	110 016 410 1010

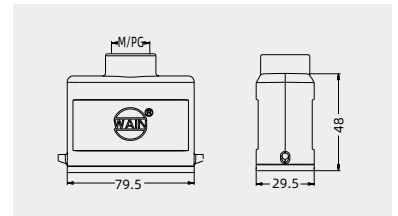

## Hoods, top entry, high construction



Thread	Designation	Order No.
M25	H16A-TEH-2B-M25	110 016 410 5003
PG16	H16A-TEH-2B-PG16	110 016 410 5010
PG21	H16A-TEH-2B-PG21	110 016 410 5011

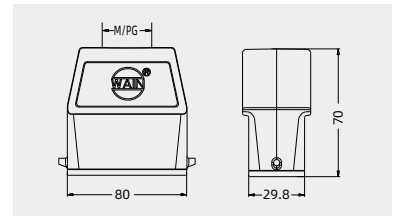

## Housings, cable to cable



Thread	Designation	Order No.
M20	H16A-CCT-1L/SC-M20	110 016 721 1002
PG13.5	H16A-CCT-1L/SC-PG13.5	110 016 721 1009
PG16	H16A-CCT-1L/SC-PG16	110 016 721 1010

Please refer to page 15-02 for choosing proper model of lock.

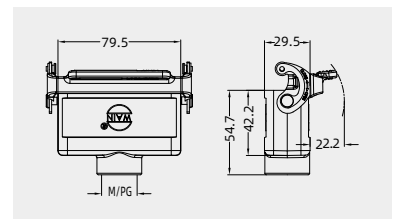

## Housings, cable to cable, high construction



Thread	Designation	Order No.
M25	H16A-CCTH-1L/SC-M25	110 016 721 5003
PG16	H16A-CCTH-1L/SC-PG16	110 016 721 5010
PG21	H16A-CCTH-1L/SC-PG21	110 016 721 5011

Please refer to page 15-02 for choosing proper model of lock.

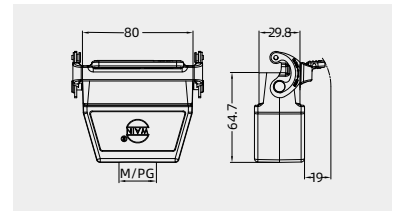

# 16A Metal hoods/housings

Degree of protection: IP65

## Bulkhead mounted housings



Thread	Designation	Order No.
---	H16A-BK-1L/SC	110 016 321 1001
	with plastic cover	
---	H16A-BK-1L/SC-CV	110 016 361 1001
	with metal cover	
---	H16A-BK-1L/SC-MCV	110 016 361 1101

Please refer to page 15-02 for choosing proper model of lock.

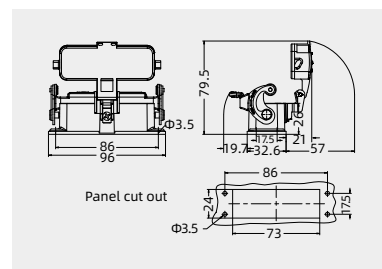

## Surface mounted housings



Thread	Designation	Order No.
M20	H16A-SF-1L/SC-M20	110 016 221 1002
2M20	H16A-SF-1L/SC-2M20	110 016 221 1022
M25	H16A-SF-1L/SC-M25	110 016 221 1003
2M25	H16A-SF-1L/SC-2M25	110 016 221 1023
PG16	H16A-SF-1L/SC-PG16	110 016 221 1010
2PG16	H16A-SF-1L/SC-2PG16	110 016 221 1030
PG21	H16A-SF-1L/SC-PG21	110 016 221 1011

	with plastic cover	
M20	H16A-SF-1L/SC-CV-M20	110 016 261 1002
2M20	H16A-SF-1L/SC-CV-2M20	110 016 261 1022
M25	H16A-SF-1L/SC-CV-M25	110 016 261 1003
2M25	H16A-SF-1L/SC-CV-2M25	110 016 261 1023
PG16	H16A-SF-1L/SC-CV-PG16	110 016 261 1010
2PG16	H16A-SF-1L/SC-CV-2PG16	110 016 261 1030
PG21	H16A-SF-1L/SC-CV-PG21	110 016 261 1011

	with metal cover	
M20	H16A-SF-1L/SC-MCV-M20	110 016 261 1102
2M20	H16A-SF-1L/SC-MCV-2M20	110 016 261 1122
M25	H16A-SF-1L/SC-MCV-M25	110 016 261 1103
2M25	H16A-SF-1L/SC-MCV-2M25	110 016 261 1123
PG16	H16A-SF-1L/SC-MCV-PG16	110 016 261 1110
2PG16	H16A-SF-1L/SC-MCV-2PG16	110 016 261 1130
PG21	H16A-SF-1L/SC-MCV-PG21	110 016 261 1111

Please refer to page 15-02 for choosing proper model of lock.

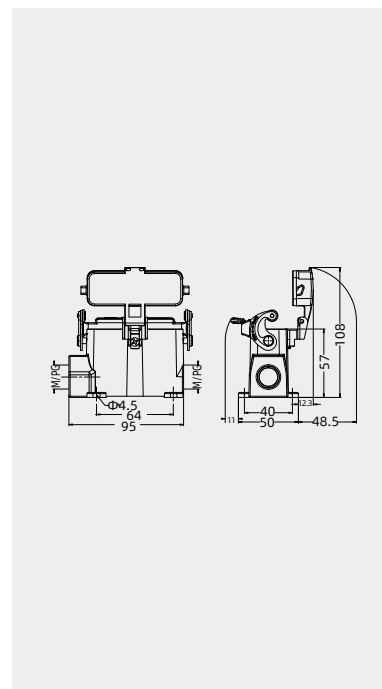

## Protection covers



Connect way	Applications	Designation	Order No.
	for hoods	H16A-MCV-1L/SC.1	110 016 021 8101

Please refer to page 15-02 for choosing proper model of lock.

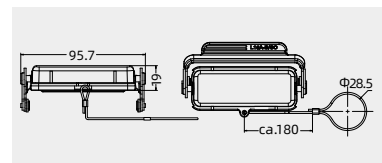

## Protection covers



Connect way	Applications	Designation	Order No.
	for housings	H16A-MCV-2B/1S	110 016 010 8101
	for housings	H16A-MCV-2B/2S	110 016 010 8102

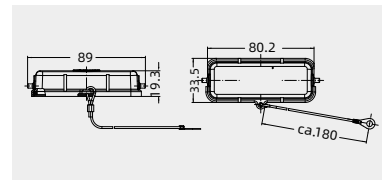

## Protection covers



Connect way	Applications	Designation	Order No.
	plastic cover (for housings)	H16A-CV-2B/2	110 016 010 8101

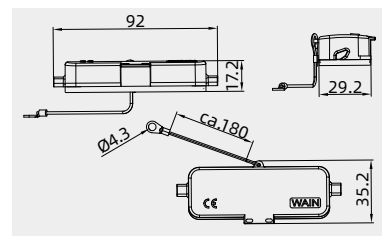

## 32A Metal hoods/housings

Degree of protection: IP65

## Hoods, side entry



Thread	Designation	Order No.
M25	H32A-SE-4B-M25	110 032 530 1003
PG21	H32A-SE-4B-PG21	110 032 530 1011

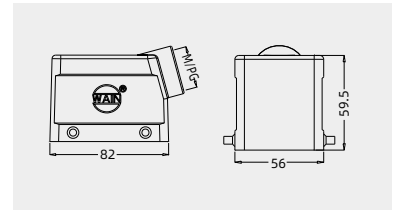

## Hoods, side entry, high construction



Thread	Designation	Order No.
M32	W32A-SEH-4B-M32	110 132 530 5001
PG21	W32A-SEH-4B-PG21	110 132 530 5002
PG29	W32A-SEH-4B-PG29	110 132 530 5003

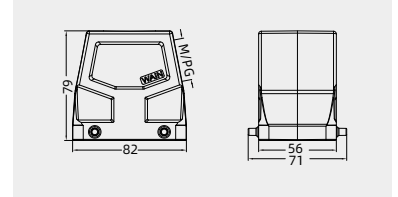

## Hoods, top entry, high construction



Thread	Designation	Order No.
M25	W32A-TEH-4B-M25	110 132 430 5001
M32	W32A-TEH-4B-M32	110 132 430 5002
PG21	W32A-TEH-4B-PG21	110 132 430 5003
PG29	W32A-TEH-4B-PG29	110 132 430 5004

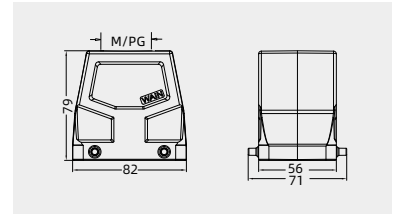

## Bulkhead mounted housings



Thread	Designation	Order No.
---	H32A-BK-2L/SC	110 032 341 1001

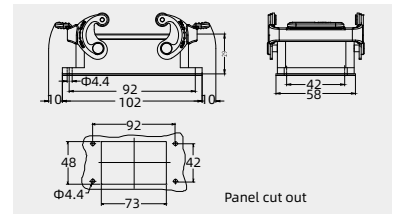

## Housings, surface mounting



Thread	Designation	Order No.
M25	H32A-SF-2L/SC-M25	110 032 241 1003
M32	H32A-SF-2L/SC-M32	110 032 241 1004
2M32	H32A-SF-2L/SC-2M32	110 032 241 1024
PG21	H32A-SF-2L/SC-PG21	110 032 241 1011
2PG21	H32A-SF-2L/SC-2PG21	110 032 241 1031
PG29	H32A-SF-2L/SC-PG29	110 032 241 1012
2PG29	H32A-SF-2L/SC-2PG29	110 032 241 1032

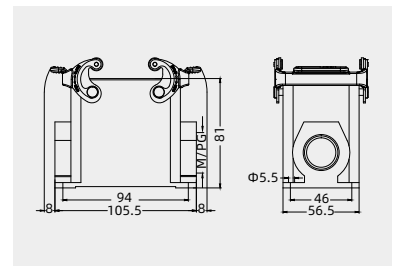

Please refer to page 15-02 for choosing proper model of lock.

Protection covers, plastic cover  
4 clamps

Connect way	Applications	Designation	Order No.
	for hoods	H32A-CV-4C	110 032 090 8009

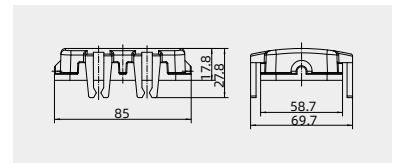

## Protection covers, plastic cover



Connect way	Applications	Designation	Order No.
	for cable to cable	H32A-CV-4B/1	110 032 030 8001
	for housings	H32A-CV-4B/2	110 032 030 8002

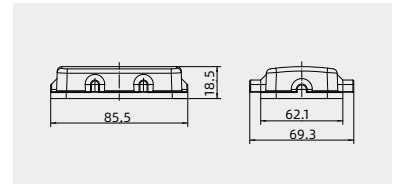

## 32A Metal hoods/housings

Degree of protection: IP65

## Hoods, side entry



Thread	Designation	Order No.
M25	H32A-SE-2L/SC-M25	110 032 541 1003
PG21	H32A-SE-2L/SC-PG21	110 032 541 1011

Please refer to page 15-02 for choosing proper model of lock.

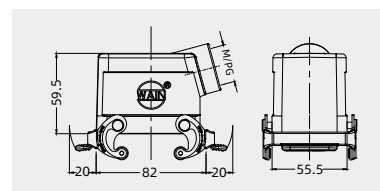

## Hoods, side entry, high construction



Thread	Designation	Order No.
M32	W32A-SEH-2L/SC-M32	110 132 541 5001
PG21	W32A-SEH-2L/SC-PG21	110 132 541 5002
PG29	W32A-SEH-2L/SC-PG29	110 132 541 5003

Please refer to page 15-02 for choosing proper model of lock.

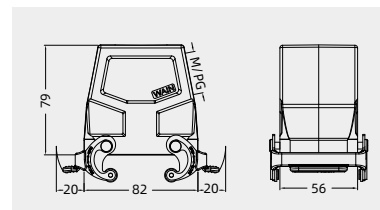

## Hoods, top entry, high construction



Thread	Designation	Order No.
M25	W32A-TEH-2L/SC-M25	110 132 441 5001
M32	W32A-TEH-2L/SC-M32	110 132 441 5002
PG21	W32A-TEH-2L/SC-PG21	110 132 441 5003
PG29	W32A-TEH-2L/SC-PG29	110 132 441 5004

Please refer to page 15-02 for choosing proper model of lock.

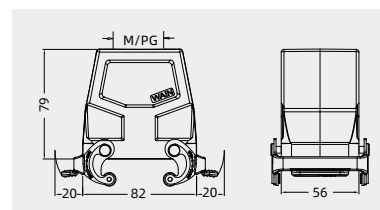

## Bulkhead mounted housings



Thread	Designation	Order No.
---	H32A-BK-4B	110 032 330 1001
---	with plastic cover	
---	H32A-BK-4B-CV	110 032 370 1001
---	with metal cover	
---	H32A-BK-4B-MCV	110 032 370 1101

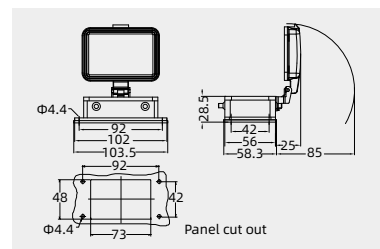

## Surface mounted housings



Thread	Designation	Order No.
M25	H32A-SF-4B-M25	110 032 230 1003
M32	H32A-SF-4B-M32	110 032 230 1004
2M32	H32A-SF-4B-2M32	110 032 230 1024
PG21	H32A-SF-4B-PG21	110 032 230 1011
2PG21	H32A-SF-4B-2PG21	110 032 230 1031
PG29	H32A-SF-4B-PG29	110 032 230 1012
2PG29	H32A-SF-4B-2PG29	110 032 230 1032

	Designation	Order No.
	with plastic cover	
M25	H32A-SF-4B-CV-M25	110 032 270 1003
M32	H32A-SF-4B-CV-M32	110 032 270 1004
2M32	H32A-SF-4B-CV-2M32	110 032 270 1024
PG21	H32A-SF-4B-CV-PG21	110 032 270 1011
2PG21	H32A-SF-4B-CV-2PG21	110 032 270 1031
PG29	H32A-SF-4B-CV-PG29	110 032 270 1012
2PG29	H32A-SF-4B-CV-2PG29	110 032 270 1032

	Designation	Order No.
	with metal cover	
M25	H32A-SF-4B-MCV-M25	110 032 270 1103
M32	H32A-SF-4B-MCV-M32	110 032 270 1104
2M32	H32A-SF-4B-MCV-2M32	110 032 270 1124
PG21	H32A-SF-4B-MCV-PG21	110 032 270 1111
2PG21	H32A-SF-4B-MCV-2PG21	110 032 270 1131
PG29	H32A-SF-4B-MCV-PG29	110 032 270 1112
2PG29	H32A-SF-4B-MCV-2PG29	110 032 270 1132

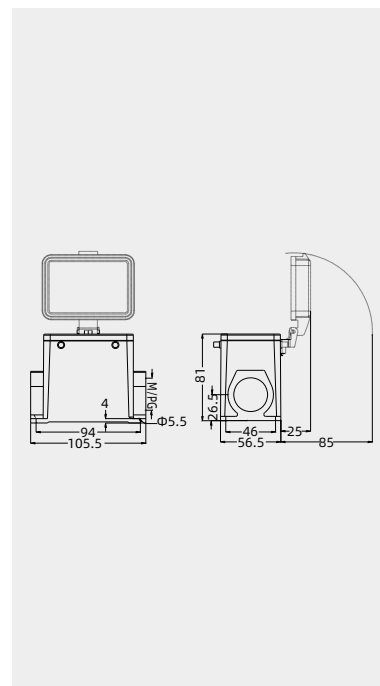

## 32A Metal hoods/housings

Degree of protection: IP67

## Hoods, side entry



Thread	Designation	Order No.
M25	W32A-SE-4B-M25	110 132 530 1001
PG21	W32A-SE-4B-PG21	110 132 530 1003

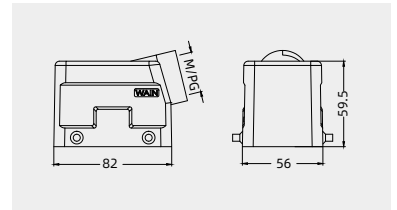

## Hoods, side entry, high construction



Thread	Designation	Order No.
M32	W32A-SEH-4B-M32	110 132 530 5001
PG21	W32A-SEH-4B-PG21	110 132 530 5002
PG29	W32A-SEH-4B-PG29	110 132 530 5003

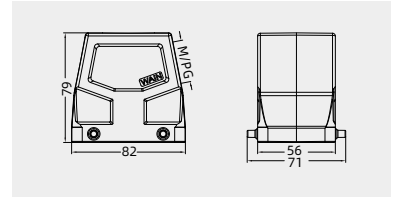

## Hoods, top entry, high construction



Thread	Designation	Order No.
M25	W32A-TEH-4B-M25	110 132 430 5001
M32	W32A-TEH-4B-M32	110 132 430 5002
PG21	W32A-TEH-4B-PG21	110 132 430 5003
PG29	W32A-TEH-4B-PG29	110 132 430 5004

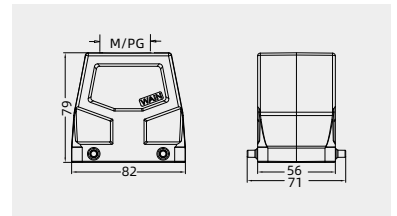

## Housings, cable to cable, high construction



Thread	Designation	Order No.
M25	W32A-CCTH-2L/SC-M25	110 132 741 5002
M32	W32A-CCTH-2L/SC-M32	110 132 741 5003
PG21	W32A-CCTH-2L/SC-PG21	110 132 741 5001
PG29	W32A-CCTH-2L/SC-PG29	110 132 741 5004

Please refer to page 15-02 for choosing proper model of lock.

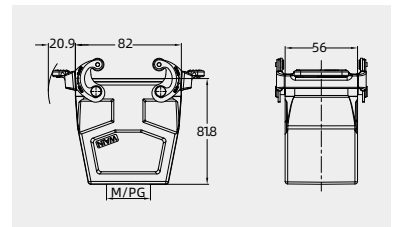

## Bulkhead mounted housings



Thread	Designation	Order No.
---	W32A-BK-2L/SC	110 132 341 1001

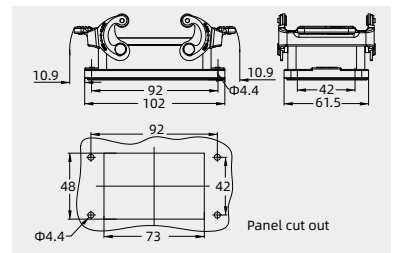



## 32A Metal hoods/housings

Degree of protection: IP67

## Hoods, side entry



Thread	Designation	Order No.
M25	W32A-SE-2L/SC-M25	110 132 541 1001
PG21	W32A-SE-2L/SC-PG21	110 132 541 1002

Please refer to page 15-02 for choosing proper model of lock.

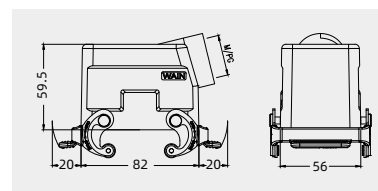

## Hoods, side entry, high construction



Thread	Designation	Order No.
M32	W32A-SEH-2L/SC-M32	110 132 541 5001
PG21	W32A-SEH-2L/SC-PG21	110 132 541 5002
PG29	W32A-SEH-2L/SC-PG29	110 132 541 5003

Please refer to page 15-02 for choosing proper model of lock.

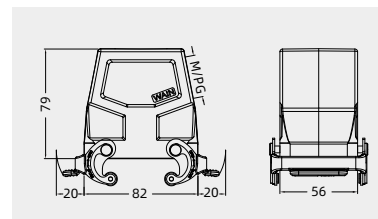

## Hoods, top entry, high construction



Thread	Designation	Order No.
M25	W32A-TEH-2L/SC-M25	110 132 441 5001
M32	W32A-TEH-2L/SC-M32	110 132 441 5002
PG21	W32A-TEH-2L/SC-PG21	110 132 441 5003
PG29	W32A-TEH-2L/SC-PG29	110 132 441 5004

Please refer to page 15-02 for choosing proper model of lock.

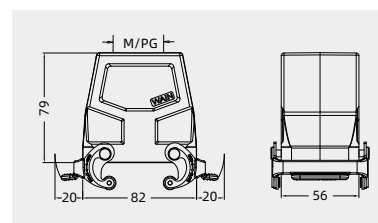

## Bulkhead mounted housings



Thread	Designation	Order No.
---	W32A-BK-4B	110 132 330 1001
---	with plastic cover	
---	W32A-BK-4B-CV	110 132 330 8001
---	with metal cover	
---	W32A-BK-4B-MCV	110 132 330 8002

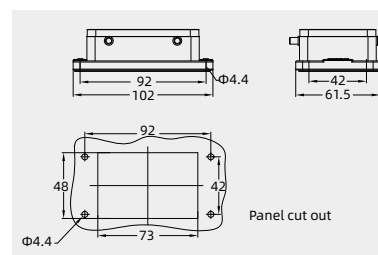

## 6B Plastic hoods/housings

Degree of protection: IP65

Hoods, side entry, high construction



Thread	Designation	Order No.
M25	H6B.P-SEH-4B-M25	117 006 530 5003
M32	H6B.P-SEH-4B-M32	117 006 530 5004

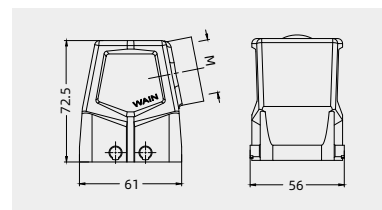

Hoods, top entry, high construction



Thread	Designation	Order No.
M25	H6B.P-TEH-4B-M25	117 006 430 5003
M32	H6B.P-TEH-4B-M32	117 006 430 5004

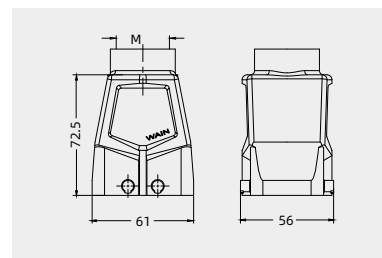

Bulkhead mounted housings



Thread	Designation	Order No.
---	H6B.P-BK-2L	117 006 347 1001

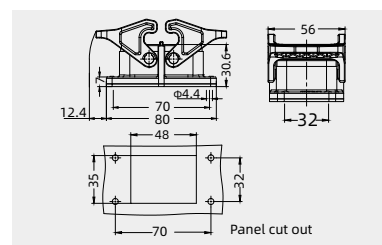

Surface mounted housings, high construction



Thread	Designation	Order No.
M25	H6B.P-SFH-2L-M25	117 006 247 5003
2M25	H6B.P-SFH-2L-2M25	117 006 247 5023
M32	H6B.P-SFH-2L-M32	117 006 247 5004
2M32	H6B.P-SFH-2L-2M32	117 006 247 5024

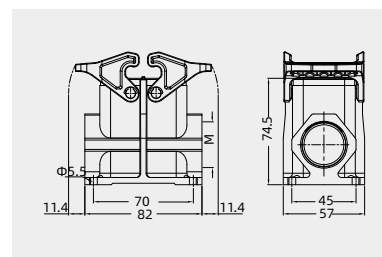

Protection covers, for housings



Connect way	Designation	Order No.
---	H6B.P-CV-4B/2	117 006 030 8002

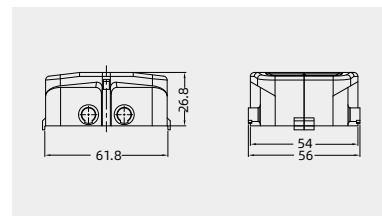

Protection covers, for hoods



Connect way	Designation	Order No.
---	H6B.P-CV-2L/1	117 006 047 8001

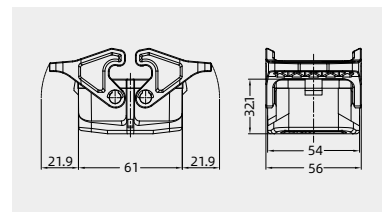

6B Modular type plastic hoods/housings

Degree of protection: IP65

Only applicable to HM module Number of modules: 3

Hoods, side entry, high construction



Thread	Designation	Order No.
M25	HM6B.P-TEH-4B-M25	129 006 437 1500
M32	HM6B.P-TEH-4B-M32	129 006 430 1500

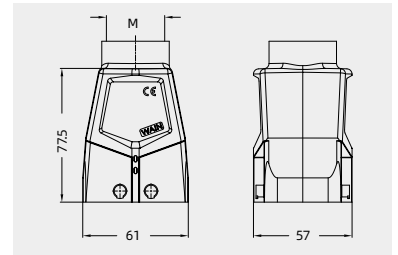

Hoods, top entry, high construction



Thread	Designation	Order No.
M25	HM6B.P-SEH-4B-M25	129 006 537 1500
M32	HM6B.P-SEH-4B-M32	129 006 530 1500

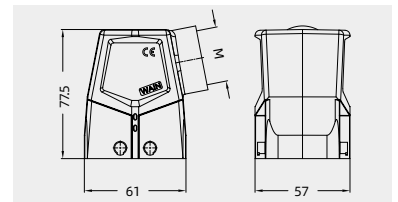

Hoods, top entry, high construction



Thread	Designation	Order No.
M25	HM6B.P-TEH-2L-M25	129 006 447 1501
M32	HM6B.P-TEH-2L-M32	129 006 447 1500

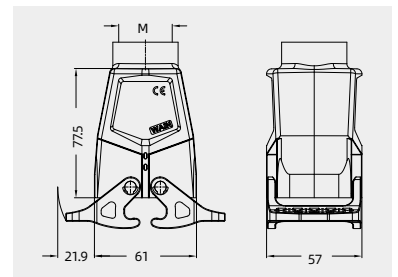

Hoods, side entry, high construction



Thread	Designation	Order No.
M25	HM6B.P-SEH-2L-M25	129 006 547 1501
M32	HM6B.P-SEH-2L-M32	129 006 547 1500

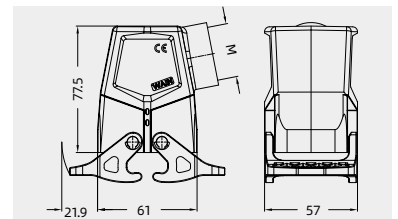

## 6B Modular type plastic hoods/housings

Degree of protection: IP65

Only applicable to HM module Number of modules: 3

## Bulkhead mounted housings



Thread	Designation	Order No.
---	HM6B.P-BK-2L	129 006 347 1500

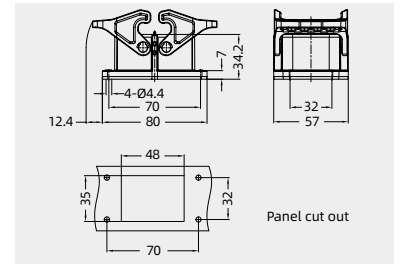

## Bulkhead mounted housings



Thread	Designation	Order No.
---	HM6B.P-BK-4B	129 006 337 1500

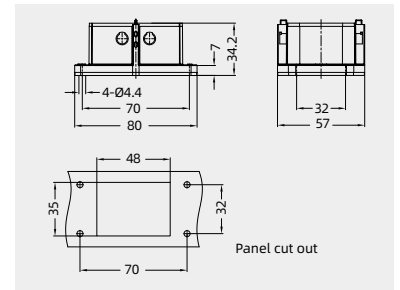

## 6B Metal hoods/housings

Degree of protection: IP65

## Hoods, side entry



Thread	Designation	Order No.
M20	H6B-SE-2B-M20	111 006 510 1002
M25	H6B-SE-2B-M25	111 006 510 1003
PG13.5	H6B-SE-2B-PG13.5	111 006 510 1009
PG16	H6B-SE-2B-PG16	111 006 510 1010

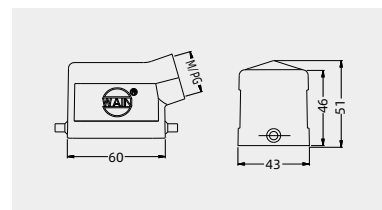

## Hoods, side entry ,high construction



Thread	Designation	Order No.
---	W6B-BEH-2B	111 106 910 5001
M25	W6B-SEH-2B-M25	111 106 510 5001
M32	W6B-SEH-2B-M32	111 106 510 5002
PG21	W6B-SEH-2B-PG21	111 106 510 5003
PG29	W6B-SEH-2B-PG29	111 106 510 5004

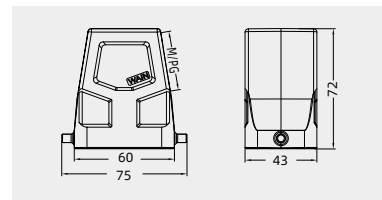

## Hoods, top entry



Thread	Designation	Order No.
M20	H6B-TE-2B-M20	111 006 410 1002
M25	H6B-TE-2B-M25	111 006 410 1003
PG13.5	H6B-TE-2B-PG13.5	111 006 410 1009
PG16	H6B-TE-2B-PG16	111 006 410 1010

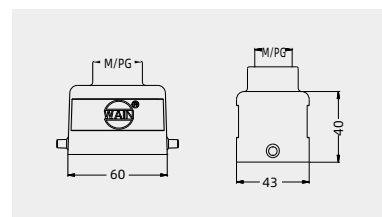

## Hoods, top entry, high construction



Thread	Designation	Order No.
---	W6B-BEH-2B	111 106 910 5001
M25	W6B-TEH-2B-M25	111 106 410 5001
M32	W6B-TEH-2B-M32	111 106 410 5002
PG21	W6B-TEH-2B-PG21	111 106 410 5003
PG29	W6B-TEH-2B-PG29	111 106 410 5004

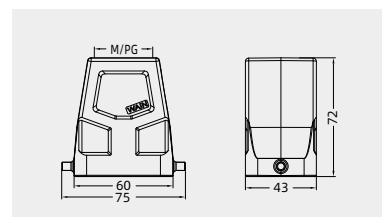

## Housings, cable to cable



Thread	Designation	Order No.
M20	H6B-CCT-1L/SC-M20	111 006 721 1002
M25	H6B-CCT-1L/SC-M25	111 006 721 1001
PG13.5	H6B-CCT-1L/SC-PG13.5	111 006 721 1009
PG16	H6B-CCT-1L/SC-PG16	111 006 721 1010

Please refer to page 15-02 for choosing proper model of lock.

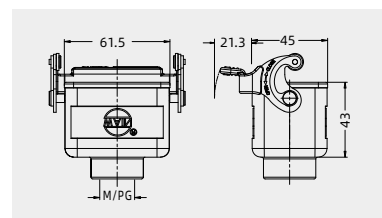

## Housings, cable to cable ,high construction



Thread	Designation	Order No.
M25	W6B-CCTH-1L/SC-M25	111 106 721 5001
M32	W6B-CCTH-1L/SC-M32	111 106 721 5002
PG21	W6B-CCTH-1L/SC-PG21	111 106 721 5003
PG29	W6B-CCTH-1L/SC-PG29	111 106 721 5004

Please refer to page 15-02 for choosing proper model of lock.

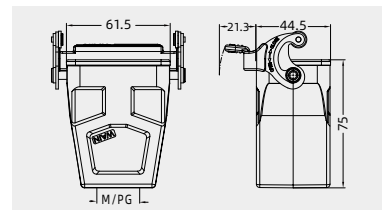

## 6B Metal hoods/housings

Degree of protection: IP65

## Bulkhead mounted housings



Thread	Designation	Order No.
---	H6B-BK-1L/SC	111 006 321 1001
	with plastic cover	
---	H6B-BK-1L/SC-CV	111 006 361 1001
	with metal cover	
---	H6B-BK-1L/SC-MCV	111 006 361 1101

Please refer to page 15-02 for choosing proper model of lock.

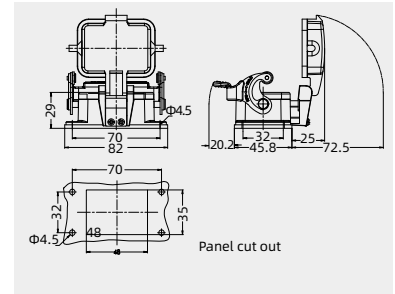

## BK hole cover plate

H



Thread	Designation	Order No.
---	6B-BK/MCV	111 006 300 8001

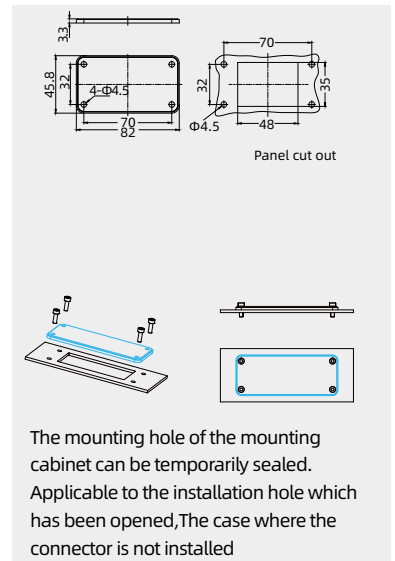

## 6B Metal hoods/housings

Degree of protection: IP65

## Surface mounted housings

## Structure 1



Thread	Designation	Order No.
M20	H6B-SF-1L/SC-M20	111 006 221 1002
2M20	H6B-SF-1L/SC-2M20	111 006 221 1022
M25	H6B-SF-1L/SC-M25 <sup>1)</sup>	111 006 221 1003
2M25	H6B-SF-1L/SC-2M25 <sup>1)</sup>	111 006 221 1023
PG16	H6B-SF-1L/SC-PG16 <sup>1)</sup>	111 006 221 1010
2PG16	H6B-SF-1L/SC-2PG16 <sup>1)</sup>	111 006 221 1030

## with plastic cover

M20	H6B-SF-1L/SC-CV-M20	111 006 261 1002
2M20	H6B-SF-1L/SC-CV-2M20	111 006 261 1022
M25	H6B-SF-1L/SC-CV-M25 <sup>1)</sup>	111 006 261 1003
2M25	H6B-SF-1L/SC-CV-2M25 <sup>1)</sup>	111 006 261 1023
PG16	H6B-SF-1L/SC-CV-PG16 <sup>1)</sup>	111 006 261 1010
2PG16	H6B-SF-1L/SC-CV-2PG16 <sup>1)</sup>	111 006 261 1030

## with metal cover

M20	H6B-SF-1L/SC-MCV-M20	111 006 261 1102
2M20	H6B-SF-1L/SC-MCV-2M20	111 006 261 1122
M25	H6B-SF-1L/SC-MCV-M25 <sup>1)</sup>	111 006 261 1103
2M25	H6B-SF-1L/SC-MCV-2M25 <sup>1)</sup>	111 006 261 1123
PG16	H6B-SF-1L/SC-MCV-PG16 <sup>1)</sup>	111 006 261 1110
2PG16	H6B-SF-1L/SC-MCV-2PG16 <sup>1)</sup>	111 006 261 1130

Please refer to page 15-02 for choosing proper model of lock.

## Structure 2

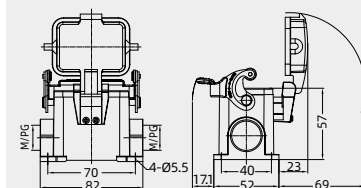

1) : Structure 1 ( \*M/PG=M25/PG16 Using Structure 1 )

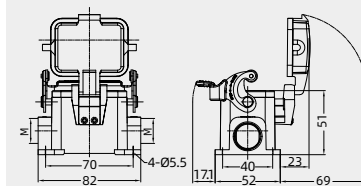

Structure 2: M=M20 Using Structure 2

## Surface mounted housings, high construction



Thread	Designation	Order No.
M25	H6B-SFH-1L/SC-M25	111 006 221 5003
2M25	H6B-SFH-1L/SC-2M25	111 006 221 5023
M32	H6B-SFH-1L/SC-M32	111 006 221 5004
2M32	H6B-SFH-1L/SC-2M32	111 006 221 5024
PG21	H6B-SFH-1L/SC-PG21	111 006 221 5011
2PG21	H6B-SFH-1L/SC-2PG21	111 006 221 5031
PG29	H6B-SFH-1L/SC-PG29	111 006 221 5012
2PG29	H6B-SFH-1L/SC-2PG29	111 006 221 5032

## with plastic cover

M25	H6B-SFH-1L/SC-CV-M25	111 006 261 5003
2M25	H6B-SFH-1L/SC-CV-2M25	111 006 261 5023
M32	H6B-SFH-1L/SC-CV-M32	111 006 261 5004
2M32	H6B-SFH-1L/SC-CV-2M32	111 006 261 5024
PG21	H6B-SFH-1L/SC-CV-PG21	111 006 261 5011
2PG21	H6B-SFH-1L/SC-CV-2PG21	111 006 261 5031
PG29	H6B-SFH-1L/SC-CV-PG29	111 006 261 5012
2PG29	H6B-SFH-1L/SC-CV-2PG29	111 006 261 5032

## with metal cover

M25	H6B-SFH-1L/SC-MCV-M25	111 006 261 5103
2M25	H6B-SFH-1L/SC-MCV-2M25	111 006 261 5123
M32	H6B-SFH-1L/SC-MCV-M32	111 006 261 5104
2M32	H6B-SFH-1L/SC-MCV-2M32	111 006 261 5124
PG21	H6B-SFH-1L/SC-MCV-PG21	111 006 261 5111
2PG21	H6B-SFH-1L/SC-MCV-2PG21	111 006 261 5131
PG29	H6B-SFH-1L/SC-MCV-PG29	111 006 261 5112
2PG29	H6B-SFH-1L/SC-MCV-2PG29	111 006 261 5132

Please refer to page 15-02 for choosing proper model of lock.

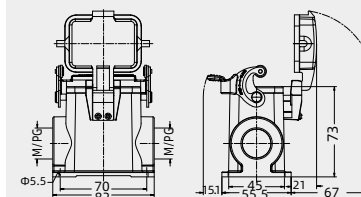

## 6B Metal hoods/housings

Degree of protection: IP65

### Protection covers



Connect way	Applications	Designation	Order No.
---	for hoods	H6B-CV-2C	111 006 000 8009

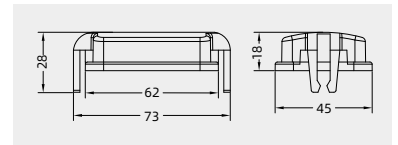

### Protection covers, metal



Connect way	Applications	Designation	Order No.
	for cable to cable housing	H6B-MCV-2B/1	111 006 010 8101
	for housings	H6B-MCV-2B/2	111 006 010 8102

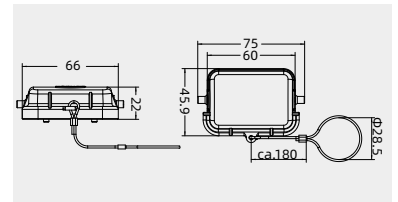

### H

### Protection covers, plastics



Connect way	Applications	Designation	Order No.
	for cable to cable housing	H6B-CV-2B/1	111 006 010 8503
	for housings	H6B-CV-2B/2	111 006 010 8504

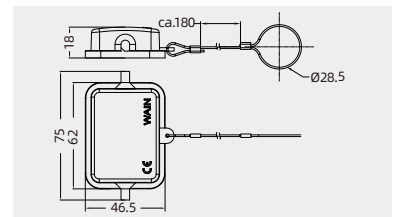

### Protection covers(IP5X)



Connect way	Applications	Designation	Order No.
---	for housings	H6B-CV/C	111 006 000 8002

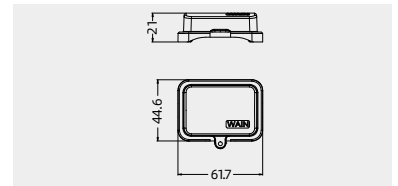

### Protection covers



Connect way	Applications	Designation	Order No.
	for hoods	H6B-MCV-1L/SC.1S	111 006 021 8101

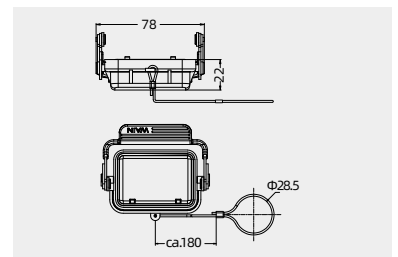

### Hoods, side entry ,high construction



Thread	Designation	Order No.
M25	W6B-SEH-1L/C-M25	111 106 550 5001
M32	W6B-SEH-1L/C-M32	111 106 550 5003
PG21	W6B-SEH-1L/C-PG21	111 106 550 5004
PG29	W6B-SEH-1L/C-PG29	111 106 550 5005

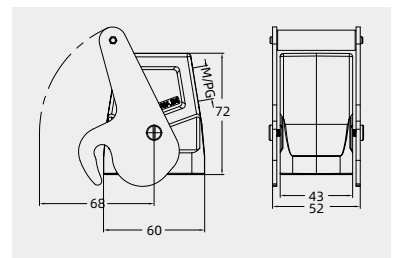

### Bulkhead mounted housings



Thread	Designation	Order No.
---	H6B-BK-2B/C	111 006 350 1003

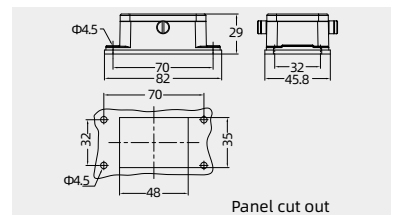

Panel cut out



## 6B Metal hoods/housings -Suitable for harsh environment(anti-corrosion)

Degree of protection: IP65

### Hoods, side entry



Thread	Designation	Order No.
M20	H6B-MSE-2B-M20	112 006 510 1002
M25	H6B-MSE-2B-M25	112 006 510 1003
PG13.5	H6B-MSE-2B-PG13.5	112 006 510 1009
PG16	H6B-MSE-2B-PG16	112 006 510 1010

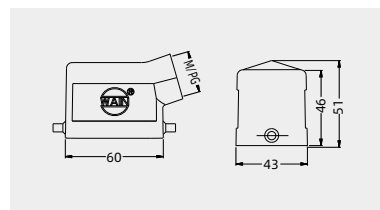

### Hoods, side entry, high construction



Thread	Designation	Order No.
M25	W6B-MSEH-2B-M25	112 106 510 5006
M32	W6B-MSEH-2B-M32	112 106 510 5004
PG21	W6B-MSEH-2B-PG21	112 106 510 5007
PG29	W6B-MSEH-2B-PG29	112 106 510 5008

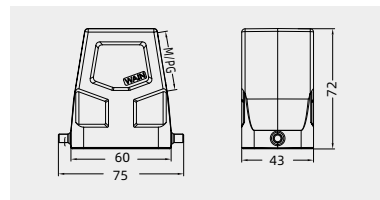

### Hoods, top entry



Thread	Designation	Order No.
M20	H6B-MTE-2B-M20	112 006 410 1002
M25	H6B-MTE-2B-M25	112 006 410 1504
PG13.5	H6B-MTE-2B-PG13.5	112 006 410 1009
PG16	H6B-MTE-2B-PG16	112 006 410 1010

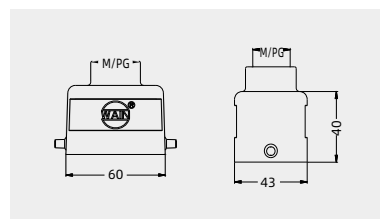

### Hoods, top entry, high construction



Thread	Designation	Order No.
M25	W6B-MTEH-2B-M25	112 106 410 5006
M32	W6B-MTEH-2B-M32	112 106 410 5008
PG21	W6B-MTEH-2B-PG21	112 106 410 5011
PG29	W6B-MTEH-2B-PG29	112 106 410 5005

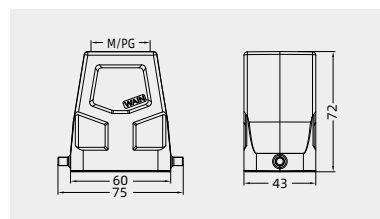

### Housings, cable to cable



Thread	Designation	Order No.
M20	H6B-MCCT-1L/SC-M20	112 006 721 1011
PG13.5	H6B-MCCT-1L/SC-PG13.5	112 006 721 1009
PG16	H6B-MCCT-1L/SC-PG16	112 006 721 1008

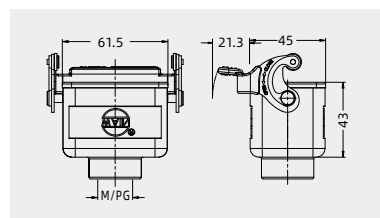

## 6B Metal hoods/housings -Suitable for harsh environment(anti-corrosion)

Degree of protection: IP65

### Bulkhead mounted housings



Thread	Designation	Order No.
---	H6B-MBK-1L/SC with metal cover	112 006 321 1001
---	H6B-MBK-1L/SC-MMCV	112 006 361 1101

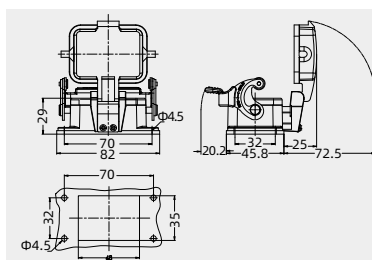

### Surface mounted housings

#### Structure 1



Thread	Designation	Order No.
M20	H6B-MSF-1L/SC-M20	112 006 221 1002
2M20	H6B-MSF-1L/SC-2M20	112 006 221 1022
M25	H6B-MSF-1L/SC-M25 <sup>1)</sup>	112 006 221 1003
2M25	H6B-MSF-1L/SC-2M25 <sup>1)</sup>	112 006 221 1001
PG16	H6B-MSF-1L/SC-PG16 <sup>1)</sup>	112 006 221 1004
2PG16	H6B-MSF-1L/SC-2PG16 <sup>1)</sup>	112 006 221 1005

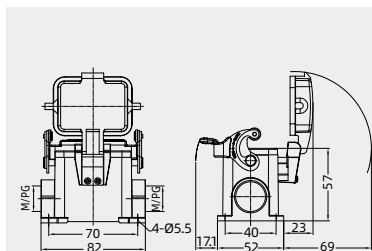

1) : Structure 1 (\*M/PG=M25/PG16 Uses Structure 1)

#### Structure 2



with metal cover		
M20	H6B-MSF-1L/SC-MMCV-M20	112 006 221 8001
2M20	H6B-MSF-1L/SC-MMCV-2M20	112 006 221 8002
M25	H6B-MSF-1L/SC-MMCV-M25 <sup>1)</sup>	112 006 221 8003
2M25	H6B-MSF-1L/SC-MMCV-2M25 <sup>1)</sup>	112 006 221 8004
PG16	H6B-MSF-1L/SC-MMCV-PG16 <sup>1)</sup>	112 006 221 8009
2PG16	H6B-MSF-1L/SC-MMCV-2PG16 <sup>1)</sup>	112 006 221 8010

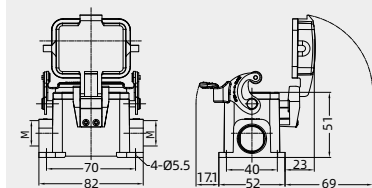

Structure 2: M=M20 Uses Structure 2

Please refer to page 15-02 for choosing proper model of lock.

### Surface mounted housings, high construction



Thread	Designation	Order No.
M25	H6B-MSFH-1L/SC-M25	112 006 221 5001
2M25	H6B-MSFH-1L/SC-2M25	112 006 221 5002
M32	H6B-MSFH-1L/SC-M32	112 006 221 5003
2M32	H6B-MSFH-1L/SC-2M32	112 006 221 5004
PG21	H6B-MSFH-1L/SC-PG21	112 006 221 1006
2PG21	H6B-MSFH-1L/SC-2PG21	112 006 221 1007
PG29	H6B-MSFH-1L/SC-PG29	112 006 221 1008
2PG29	H6B-MSFH-1L/SC-2PG29	112 006 221 1009

with metal cover		
M25	H6B-MSFH-1L/SC-MMCV-M25	112 006 221 8005
2M25	H6B-MSFH-1L/SC-MMCV-2M25	112 006 221 8006
M32	H6B-MSFH-1L/SC-MMCV-M32	112 006 221 8007
2M32	H6B-MSFH-1L/SC-MMCV-2M32	112 006 221 8008
PG21	H6B-MSFH-1L/SC-MMCV-PG21	112 006 221 8011
2PG21	H6B-MSFH-1L/SC-MMCV-2PG21	112 006 221 8012
PG29	H6B-MSFH-1L/SC-MMCV-PG29	112 006 221 8013
2PG29	H6B-MSFH-1L/SC-MMCV-2PG29	112 006 221 8014

Please refer to page 15-02 for choosing proper model of lock.

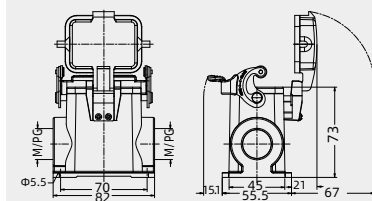

6B Metal hoods/housings  
 -Suitable for harsh environment(anti-corrosion)

Degree of protection: IP65

Protection covers



Connect way	Designation	Order No.
	H6B-MMCV-2B/1	112 006 010 8001
	H6B-MMCV-2B/2	112 006 010 8002

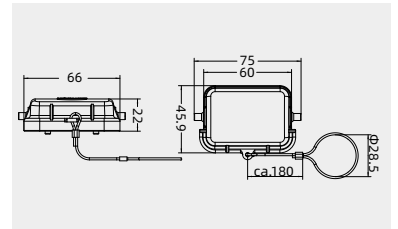

Protection covers



Connect way	Applications	Designation	Order No.
	for hoods	H6B-MMCV-1L/SC.1S	112 006 021 8001

Please refer to page 15-02 for choosing proper model of lock.

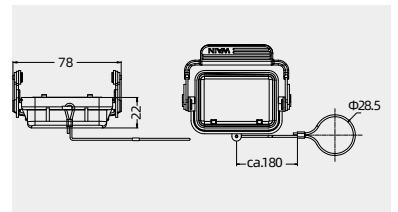

## 6B Metal hoods/housings

Degree of protection: IP67

## Hoods, side entry



Thread	Designation	Order No.
M20	W6B-SE-2B-M20	111 106 510 1001
M25	W6B-SE-2B-M25	111 106 510 1002
PG13.5	W6B-SE-2B-PG13.5	111 106 510 1003
PG16	W6B-SE-2B-PG16	111 106 510 1004

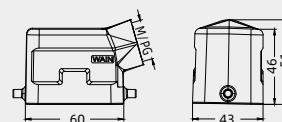

## Hoods, side entry, high construction



Thread	Designation	Order No.
---	W6B-BEH-2B	111 106 910 5001
M25	W6B-SEH-2B-M25	111 106 510 5001
M32	W6B-SEH-2B-M32	111 106 510 5002
PG21	W6B-SEH-2B-PG21	111 106 510 5003
PG29	W6B-SEH-2B-PG29	111 106 510 5004

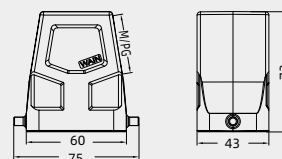

## Hoods, top entry



Thread	Designation	Order No.
M20	W6B-TE-2B-M20	111 106 410 1001
M25	W6B-TE-2B-M25	111 106 410 1002
PG13.5	W6B-TE-2B-PG13.5	111 106 410 1003
PG16	W6B-TE-2B-PG16	111 106 410 1004

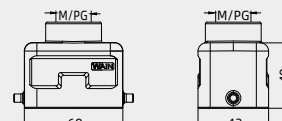

## Hoods, top entry, high construction



Thread	Designation	Order No.
---	W6B-BEH-2B	111 106 910 5001
M25	W6B-TEH-2B-M25	111 106 410 5001
M32	W6B-TEH-2B-M32	111 106 410 5002
PG21	W6B-TEH-2B-PG21	111 106 410 5003
PG29	W6B-TEH-2B-PG29	111 106 410 5004

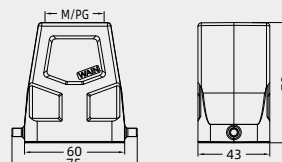

## Housings, cable to cable



Thread	Designation	Order No.
M20	W6B-CCT-1L/SC-M20	111 106 721 1005
M25	W6B-CCT-1L/SC-M25	111 106 721 1008
PG13.5	W6B-CCT-1L/SC-PG13.5	111 106 721 1006
PG16	W6B-CCT-1L/SC-PG16	111 106 721 1007

Please refer to page 15-02 for choosing proper model of lock.

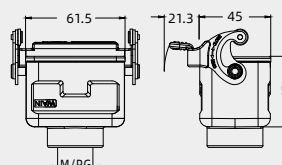

## Housings, cable to cable, high construction



Thread	Designation	Order No.
M25	W6B-CCTH-1L/SC-M25	111 106 721 5001
M32	W6B-CCTH-1L/SC-M32	111 106 721 5002
PG21	W6B-CCTH-1L/SC-PG21	111 106 721 5003
PG29	W6B-CCTH-1L/SC-PG29	111 106 721 5004

Please refer to page 15-02 for choosing proper model of lock.

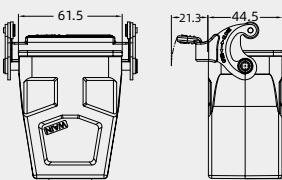

## 6B Metal hoods/housings

Degree of protection: IP67

## Bulkhead mounted housings



Thread	Designation	Order No.
---	W6B-BK-1L/SC	111 106 321 1002
	with plastic cover	
---	W6B-BK-1L/SC-CV	111 106 321 8001
	with metal cover	
---	W6B-BK-1L/SC-MCV	111 106 321 8002

Please refer to page 15-02 for choosing proper model of lock.

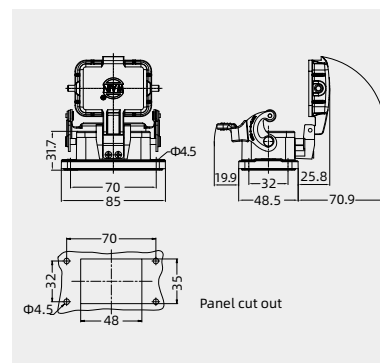

## Hoods, side entry, high construction



Thread	Designation	Order No.
M25	W6B-SEH-1L/C-M25	111 106 550 5001
M32	W6B-SEH-1L/C-M32	111 106 550 5003
PG21	W6B-SEH-1L/C-PG21	111 106 550 5004
PG29	W6B-SEH-1L/C-PG29	111 106 550 5005

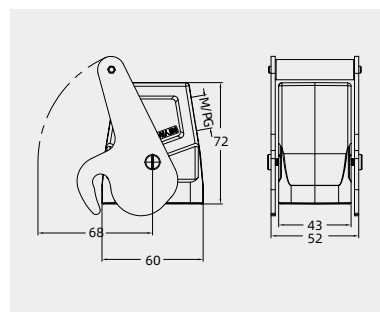

## Bulkhead mounted housings



Thread	Designation	Order No.
---	W6B-BK-2B/C	111 106 350 1001

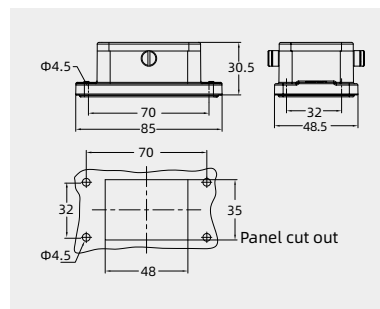

## 6B Metal hoods/housings -Suitable for harsh environment(anti-corrosion)

Degree of protection: IP67

### Hoods, side entry



Thread	Designation	Order No.
M20	W6B-MSE-2B-M20	112 106 510 1001
M25	W6B-MSE-2B-M25	112 106 510 1004
PG13.5	W6B-MSE-2B-PG13.5	112 106 510 1002
PG16	W6B-MSE-2B-PG16	112 106 510 1003

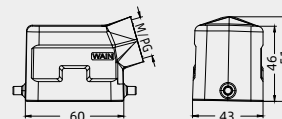

### Hoods, side entry, high construction



Thread	Designation	Order No.
M25	W6B-MSEH-2B-M25	112 106 510 5006
M32	W6B-MSEH-2B-M32	112 106 510 5004
PG21	W6B-MSEH-2B-PG21	112 106 510 5007
PG29	W6B-MSEH-2B-PG29	112 106 510 5008

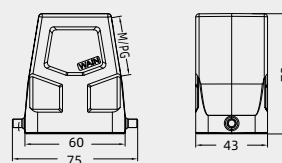

### Hoods, top entry



Thread	Designation	Order No.
M20	W6B-MTE-2B-M20	112 106 410 1001
M25	W6B-MTE-2B-M25	112 106 410 1004
PG13.5	W6B-MTE-2B-PG13.5	112 106 410 1002
PG16	W6B-MTE-2B-PG16	112 106 410 1003

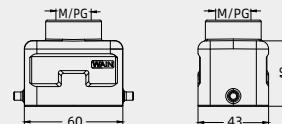

### Hoods, top entry, high construction



Thread	Designation	Order No.
M25	W6B-MTEH-2B-M25	112 106 410 5006
M32	W6B-MTEH-2B-M32	112 106 410 5008
PG21	W6B-MTEH-2B-PG21	112 106 410 5011
PG29	W6B-MTEH-2B-PG29	112 106 410 5005

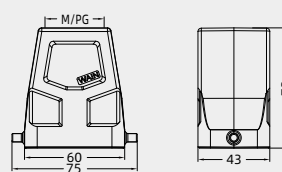

### Housings, cable to cable



Thread	Designation	Order No.
M20	W6B-MCCT-1L/SC-M20	112 106 721 1001
M25	W6B-MCCT-1L/SC-M25	112 106 721 1004
PG13.5	W6B-MCCT-1L/SC-PG13.5	112 106 721 1002
PG16	W6B-MCCT-1L/SC-PG16	112 106 721 1003

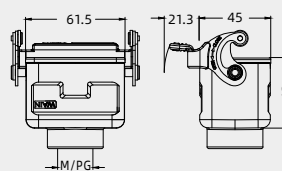

### Housings, cable to cable, high construction



Thread	Designation	Order No.
M25	W6B-MCCTH-1L/SC-M25	112 106 721 5001
M32	W6B-MCCTH-1L/SC-M32	112 106 721 5002
PG21	W6B-MCCTH-1L/SC-PG21	112 106 721 5003
PG29	W6B-MCCTH-1L/SC-PG29	112 106 721 5004

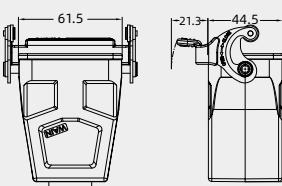

### Bulkhead mounted housings



Thread	Designation	Order No.
---	W6B-MBK-1L/SC	112 106 321 1001
---	W6B-MBK-1L/SC-MMCV	112 106 321 8001

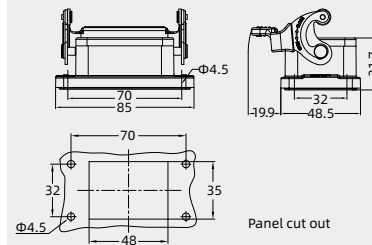

## 6B EMC Metal hoods/housings

Degree of protection: IP67

## Hoods, side entry



Thread	Designation	Order No.
M20	EMC.W6B-SE-2B-M20	111 206 510 1004
M25	EMC.W6B-SE-2B-M25	111 206 510 1001
PG13.5	EMC.W6B-SE-2B-PG13.5	111 206 510 1002
PG16	EMC.W6B-SE-2B-PG16	111 206 510 1003

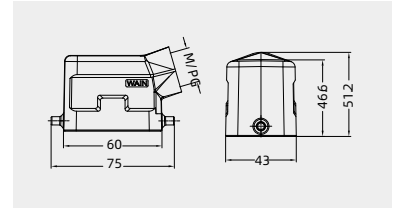

## Hoods, side entry, high construction



Thread	Designation	Order No.
M25	EMC.W6B-SEH-2B-M25	111 206 510 5001
M32	EMC.W6B-SEH-2B-M32	111 206 510 5002
PG21	EMC.W6B-SEH-2B-PG21	111 206 510 5003
PG29	EMC.W6B-SEH-2B-PG29	111 206 510 5004

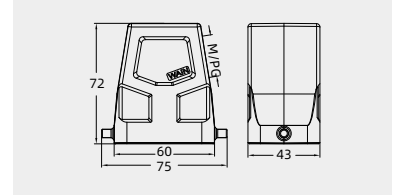

## Hoods, top entry



Thread	Designation	Order No.
M20	EMC.W6B-TE-2B-M20	111 206 410 1001
M25	EMC.W6B-TE-2B-M25	111 206 410 1002
PG13.5	EMC.W6B-TE-2B-PG13.5	111 206 410 1003
PG16	EMC.W6B-TE-2B-PG16	111 206 410 1004

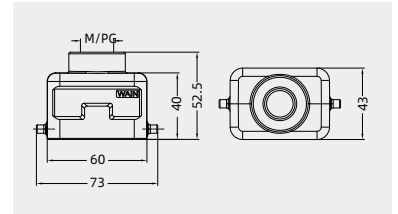

## Hoods, top entry, high construction



Thread	Designation	Order No.
M25	EMC.W6B-TEH-2B-M25	111 206 410 5001
M32	EMC.W6B-TEH-2B-M32	111 206 410 5002
PG21	EMC.W6B-TEH-2B-PG21	111 206 410 5003
PG29	EMC.W6B-TEH-2B-PG29	111 206 410 5004

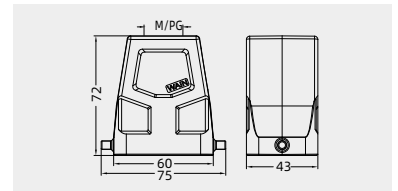

## Bulkhead mounted housings



Thread	Designation	Order No.
---	EMC1.W6B-BK-1L/SC	111 106 321 1001

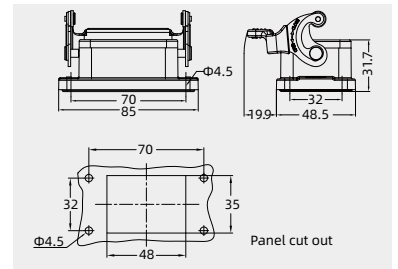

## 6B EMC Metal hoods/housings

Degree of protection: IP65



## Hoods, top entry



Thread	Designation	Order No.
M20	EMC.H6B-SF-1L/SC-M20	111 606 221 1500
2M20	EMC.H6B-SF-1L/SC-2M20	111 606 221 1501
PG16	EMC.H6B-SF-1L/SC-PG16	111 606 221 1502
2PG16	EMC.H6B-SF-1L/SC-2PG16	111 606 221 1503

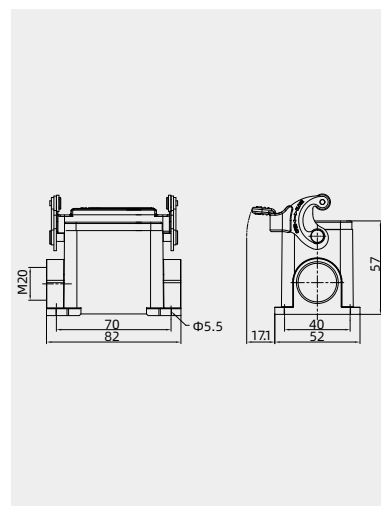

H

## Hoods, side entry, high construction



Thread	Designation	Order No.
M25	EMC.H6B-SFH-1L/SC-M25	111 606 221 5501
M32	EMC.H6B-SFH-1L/SC-2M25	111 606 221 5502
PG21	EMC.H6B-SFH-1L/SC-M32	111 606 221 5503
PG29	EMC.H6B-SFH-1L/SC-2M32	111 606 221 5504
PG21	EMC.H6B-SFH-1L/SC-PG21	111 606 221 5505
2PG21	EMC.H6B-SFH-1L/SC-2PG21	111 606 221 5506
PG29	EMC.H6B-SFH-1L/SC-PG29	111 606 221 5507
2PG29	EMC.H6B-SFH-1L/SC-2PG29	111 606 221 5508

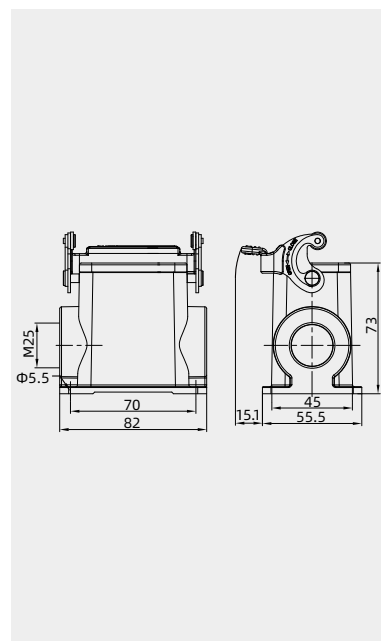



## 6B Pressure tight hoods/housings

Degree of protection: IP68/IP69K

W version

## Hoods, side entry, high construction



Thread	Designation	Order No.
M20	HP6B-SEH-2S-M20	115 006 520 5102
M25	HP6B-SEH-2S-M25	115 006 520 5103
M32	HP6B-SEH-2S-M32	115 006 520 5104
PG16	HP6B-SEH-2S-PG16	115 006 520 5110
PG21	HP6B-SEH-2S-PG21	115 006 520 5111

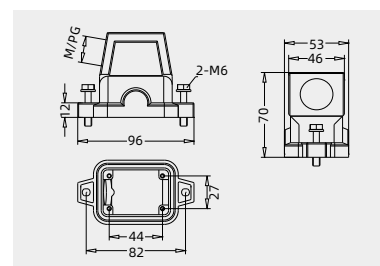

## Hoods, side entry, high construction



Thread	Designation	Order No.
M20	HP6B-TEH-2S-M20	115 006 420 5102
M25	HP6B-TEH-2S-M25	115 006 420 5103
M32	HP6B-TEH-2S-M32	115 006 420 5104
PG16	HP6B-TEH-2S-PG16	115 006 420 5110
PG21	HP6B-TEH-2S-PG21	115 006 420 5111
PG29	HP6B-TEH-2S-PG29	115 006 420 5112

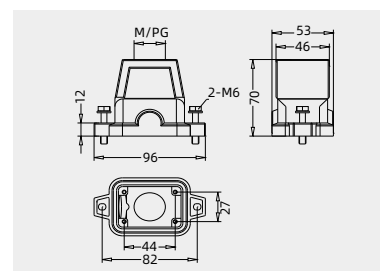

## Surface mounted housings, high construction



Thread	Designation	Order No.
M20	HP6B-SFH-2H-M20	115 006 220 5002
M25	HP6B-SFH-2H-M25	115 006 220 5003
M32	HP6B-SFH-2H-M32	115 006 220 5004
PG16	HP6B-SFH-2H-PG16	115 006 220 5010
PG21	HP6B-SFH-2H-PG21	115 006 220 5011

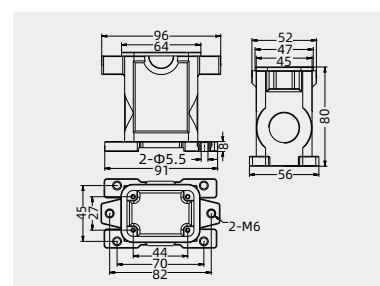

## Bulkhead mounted housings



Thread	Designation	Order No.
---	HP6B-BK-2H	115 006 320 1001

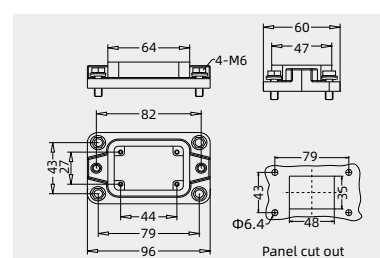

## Protection covers, plastic



Connect way	Designation	Order No.
---	HP6B-CV-2S/2	115 006 020 8002

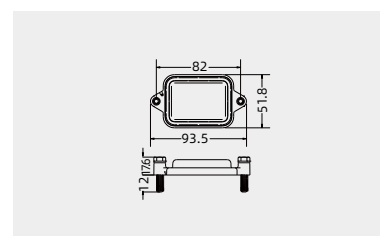

## WP6B/R Pressure tight hoods/housings

Degree of protection: IP68/IP69K

W version

Hoods, top entry, high construction



Thread	Designation	Order No.
M20	WP6B/R-TEH-2S-M20	111 106 420 1002
M25	WP6B/R-TEH-2S-M25	111 106 420 1001

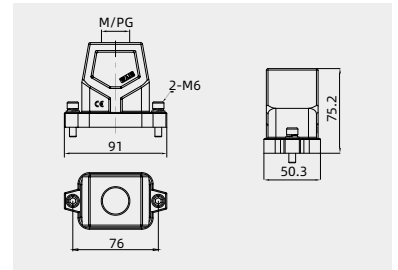

Through-wall housing, high construction



Thread	Designation	Order No.
M20	WP6B/R-CCT/BK-2H-M20	111 106 720 1001
M25	WP6B/R-CCT/BK-2H-M25	111 106 720 1002

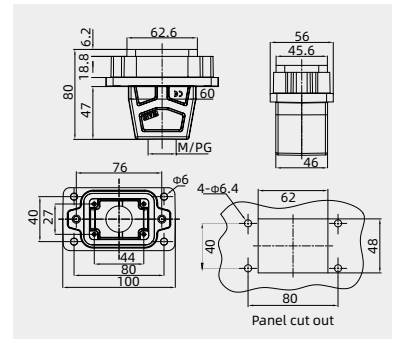

## 6B Pressure tight hoods/housings

Degree of protection: IP68/IP69K

H version

## Hoods, side entry, high construction



Thread	Designation	Order No.
	Screw locking	
M20	HP6B/H-SEH-2S-M20	113 606 520 5002
M25	HP6B/H-SEH-2S-M25	113 606 520 5003
M32	HP6B/H-SEH-2S-M32	113 606 520 5004
M40	HP6B/H-SEH-2S-M40	113 606 520 5005
PG16	HP6B/H-SEH-2S-PG16	113 606 520 5010
PG21	HP6B/H-SEH-2S-PG21	113 606 520 5011
PG29	HP6B/H-SEH-2S-PG29	113 606 520 5012
	Toggle locking	
M20	HP6B/H-SEH-2T-M20	113 606 540 5002
M25	HP6B/H-SEH-2T-M25	113 606 540 5003
M32	HP6B/H-SEH-2T-M32	113 606 540 5004
M40	HP6B/H-SEH-2T-M40	113 606 540 5005
PG16	HP6B/H-SEH-2T-PG16	113 606 540 5010
PG21	HP6B/H-SEH-2T-PG21	113 606 540 5011
PG29	HP6B/H-SEH-2T-PG29	113 606 540 5012

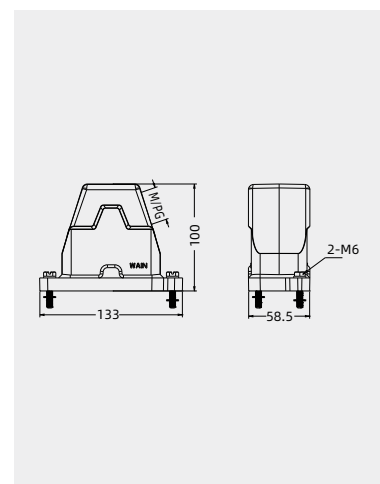

## Hoods, top entry, high construction



Thread	Designation	Order No.
	Screw locking	
M20	HP6B/H-TEH-2S-M20	113 606 420 5002
M25	HP6B/H-TEH-2S-M25	113 606 420 5003
M32	HP6B/H-TEH-2S-M32	113 606 420 5004
PG16	HP6B/H-TEH-2S-PG16	113 606 420 5010
PG21	HP6B/H-TEH-2S-PG21	113 606 420 5011
PG29	HP6B/H-TEH-2S-PG29	113 606 420 5012
	Toggle locking	
M20	HP6B/H-TEH-2T-M20	113 606 440 5002
M25	HP6B/H-TEH-2T-M25	113 606 440 5003
M32	HP6B/H-TEH-2T-M32	113 606 440 5004
PG16	HP6B/H-TEH-2T-PG16	113 606 440 5010
PG21	HP6B/H-TEH-2T-PG21	113 606 440 5011
PG29	HP6B/H-TEH-2T-PG29	113 606 440 5012

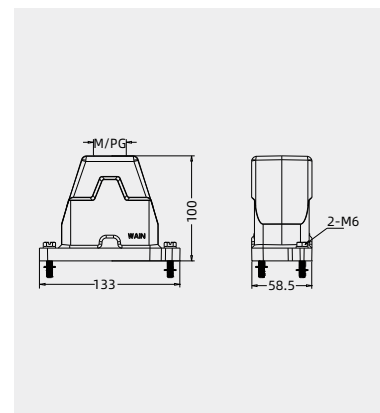

## Housing, side entry, high construction



Thread	Designation	Order No.
	Screw locking	
M20	HP6B/H-SFH-2H-M20	113 606 220 5002
M25	HP6B/H-SFH-2H-M25	113 606 220 5003
M32	HP6B/H-SFH-2H-M32	113 606 220 5004
PG16	HP6B/H-SFH-2H-PG16	113 606 220 5010
PG21	HP6B/H-SFH-2H-PG21	113 606 220 5011
PG29	HP6B/H-SFH-2H-PG29	113 606 220 5012
	Toggle locking	
M20	HP6B/H-SFH-2T-M20	113 606 240 5002
M25	HP6B/H-SFH-2T-M25	113 606 240 5003
M32	HP6B/H-SFH-2T-M32	113 606 240 5004
PG16	HP6B/H-SFH-2T-PG16	113 606 240 5010
PG21	HP6B/H-SFH-2T-PG21	113 606 240 5011
PG29	HP6B/H-SFH-2T-PG29	113 606 240 5012

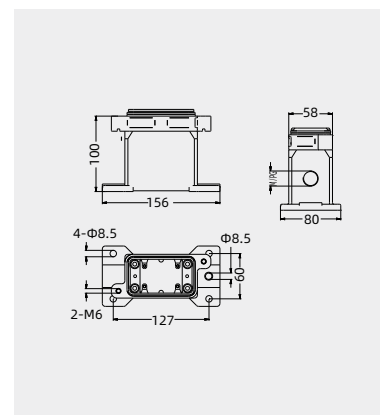

## Bulkhead mounted housings



Thread	Designation	Order No.
	Screw locking	
---	HP6B/H-BK-2H	113 606 320 1001
	Toggle locking	
---	HP6B/H-BK-2T	113 606 340 1001
	with metal cover	
	Screw locking	
---	HP6B/H-BK-2H-MCV	113 606 360 1001
	Toggle locking	
---	HP6B/H-BK-2T-MCV	113 606 370 1001

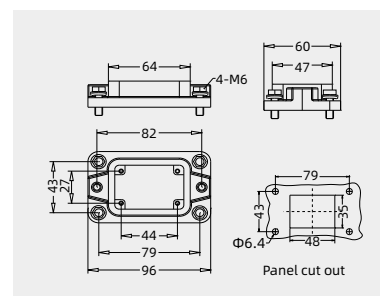

## 6B Pressure tight hoods/housings

Degree of protection: IP68/IP69K



H version

## Surface mounted housings



Thread	Designation	Order No.
	Toggle locking	
M25	HP6B/H-BK-SE-2H-M25	113 606 920 1501
M25	HP6B/H-BK-SE-2T-M25	113 606 940 1500

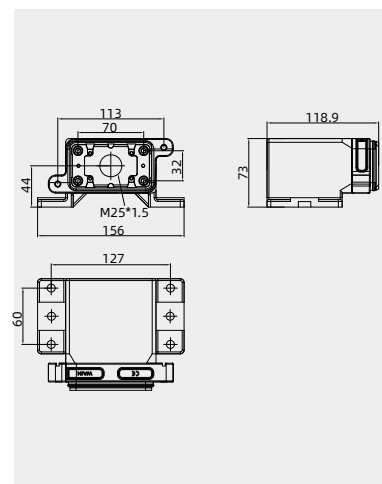

## Protection covers, for housings



Connect way	Designation	Order No.
	Screw locking	
	HP6B/H-MCV-2S	113 606 020 8101
	Toggle locking	
	HP6B/H-MCV-2T	113 606 040 8103

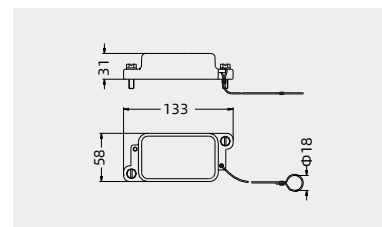

## Protection covers, for hoods



Connect way	Designation	Order No.
	Screw locking	
	HP6B/H-MCV-2H/1	113 606 020 8111
	Toggle locking	
	HP6B/H-MCV-2T/1	113 606 040 8101

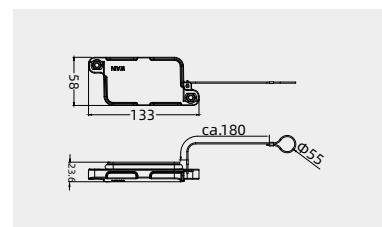

## Protection covers, for housings(IP5X)



Connect way	Designation	Order No.
---	HP6B/H-CV/C	113 006 900 8002

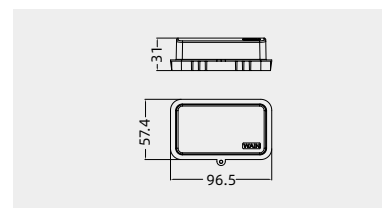

6B Pressure tight hoods/housings

Degree of protection: IP68/IP69K

The following hoods/housings comply with the standards for rail transport industry in China.

H version

Hoods, top entry, high construction



Thread	Designation	Order No.
M20	HP6B/H-SEH-4S-M20	113 606 530 5002
M25	HP6B/H-SEH-4S-M25	113 606 530 5003
M32	HP6B/H-SEH-4S-M32	113 606 530 5004
M40	HP6B/H-SEH-4S-M40	113 606 530 5005
PG16	HP6B/H-SEH-4S-PG16	113 606 530 5010
PG21	HP6B/H-SEH-4S-PG21	113 606 530 5011

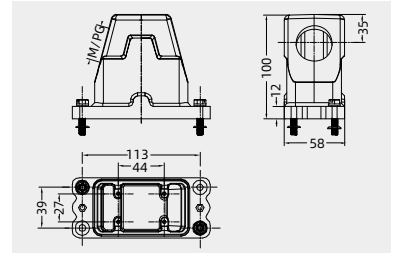

Hoods, top entry, high construction



Thread	Designation	Order No.
M20	HP6B/H-TEH-4S-M20	113 606 430 5002
M25	HP6B/H-TEH-4S-M25	113 606 430 5003
M32	HP6B/H-TEH-4S-M32	113 606 430 5004
M40	HP6B/H-TEH-4S-M40	113 606 430 5005
PG16	HP6B/H-TEH-4S-PG16	113 606 430 5010
PG21	HP6B/H-TEH-4S-PG21	113 606 430 5011
PG29	HP6B/H-TEH-4S-PG29	113 606 430 5012

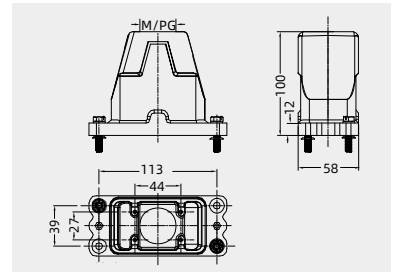

Bulkhead mounted housings



Thread	Designation	Order No.
---	HP6B/H-BK-4H	113 606 330 1001

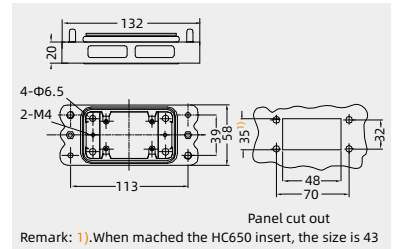

Surface mounted housings



Thread	Designation	Order No.
M25	HP6B/H-BK-SE-4H-M25	113 606 930 1500

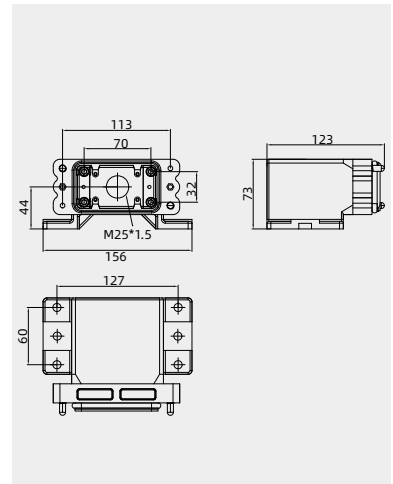

## 6B Pressure tight hoods/housings/EMC Pressure tight hoods/housings

Degree of protection: IP68/IP69K

## Hoods, side entry, high construction



Thread	Designation	Order No.
M20	HC6B-SEH-2S-M20	114 006 520 5002
M25	HC6B-SEH-2S-M25	114 006 520 5003
PG16	HC6B-SEH-2S-PG16	114 006 520 5010
PG21	HC6B-SEH-2S-PG21	114 006 520 5011

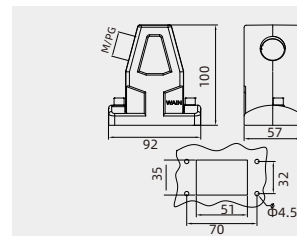

## Hoods, top entry, high construction



Thread	Designation	Order No.
M20	HC6B-TEH-2S-M20	114 006 420 5002
M25	HC6B-TEH-2S-M25	114 006 420 5003
PG16	HC6B-TEH-2S-PG16	114 006 420 5010
PG21	HC6B-TEH-2S-PG21	114 006 420 5011

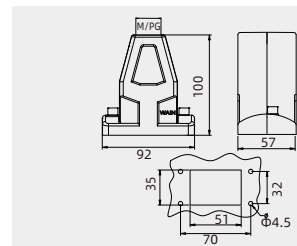

## Mounting flange



Applications	Designation	Order No.
for integral type hoods	APT-C	114 000 000 1001

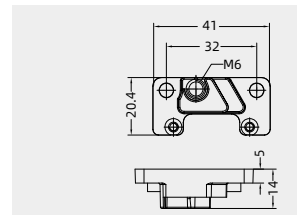

## Protection covers, plastic



Thread	Designation	Order No.
---	HC6B-CV-2S/2	111 006 020 8001

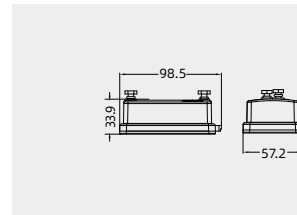

## 6B Pressure tight hoods/housings/EMC Pressure tight hoods/housings

Degree of protection: IP68/IP69K

EMC Pressure tight hoods/housings

## Hoods, top entry, high construction



Thread	Designation	Order No.
M20	EMC.W6B-TEH-4S-M20	111 106 430 5003
M25	EMC.W6B-TEH-4S-M25	111 106 430 5001
M32	EMC.W6B-TEH-4S-M32	111 106 430 5002
PG21	EMC.W6B-TEH-4S-PG21	111 106 430 5004
PG29	EMC.W6B-TEH-4S-PG29	111 106 430 5005

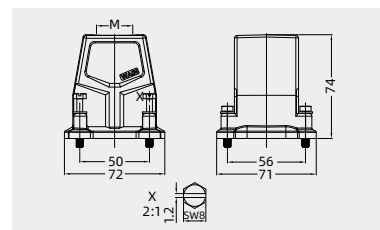

## Hoods, side entry, high construction



Thread	Designation	Order No.
M20	EMC.W6B-SEH-4S-M20	111 206 530 5001
M25	EMC.W6B-SEH-4S-M25	111 206 530 5002
M32	EMC.W6B-SEH-4S-M32	111 206 530 5003
PG21	EMC.W6B-SEH-4S-PG21	111 206 530 5004
PG29	EMC.W6B-SEH-4S-PG29	111 206 530 5005

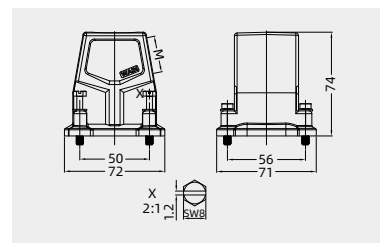

## Bulkhead mounted housings



Thread	Designation	Order No.
---	EMC.W6B-BK-4H	111 206 330 1001

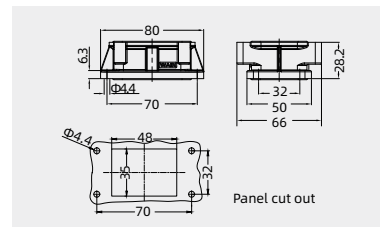





## 10B Plastic hoods/housings

Degree of protection: IP65

## Hoods, side entry, high construction



Thread	Designation	Order No.
M25	H10B.P-SEH-4B-M25	117 010 530 5003
M32	H10B.P-SEH-4B-M32	117 010 530 5004

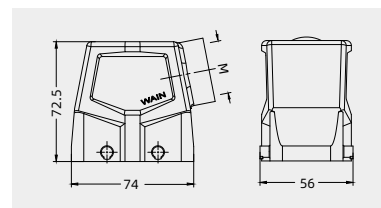

## Hoods, top entry, high construction



Thread	Designation	Order No.
M25	H10B.P-TEH-4B-M25	117 010 430 5003
M32	H10B.P-TEH-4B-M32	117 010 430 5004

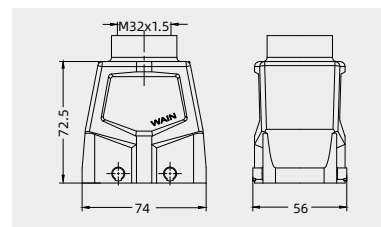

## Bulkhead mounted housings



Thread	Designation	Order No.
---	H10B.P-BK-2L	117 010 340 1001

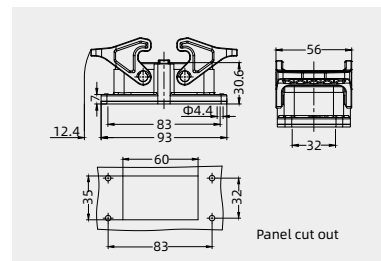

## Surface mounted housings, high construction



Thread	Designation	Order No.
M25	H10B.P-SFH-2L-M25	117 010 247 5003
2M25	H10B.P-SFH-2L-2M25	117 010 247 5023
M32	H10B.P-SFH-2L-M32	117 010 247 5004
2M32	H10B.P-SFH-2L-2M32	117 010 247 5024

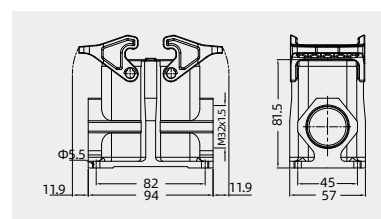

## Protection covers, for housings



Connect way	Designation	Order No.
---	H10B.P-CV-4B/2	117 010 030 8002

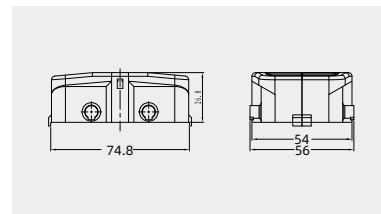

## Protection covers, for hoods



Connect way	Designation	Order No.
---	H10B.P-CV-2L/1	117 010 040 8001

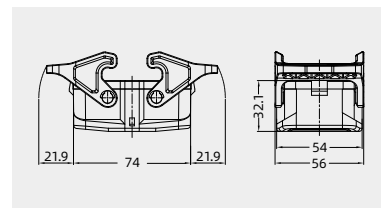

10B Modular type plastic hoods/housings

Degree of protection: IP65

Only suitable for HM series.

Number of modules: 4

Hoods, top entry, high construction



Thread	Designation	Order No.
M32	HM10B.P-TEH-4B-M32	129 010 430 5500
M40	HM10B.P-TEH-4B-M40	129 010 430 5001

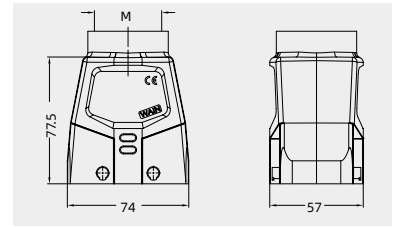

Hoods, side entry, high construction



Thread	Designation	Order No.
M32	HM10B.P-SEH-4B-M32	129 010 537 1500
M40	HM10B.P-SEH-4B-M40	129 010 530 5001

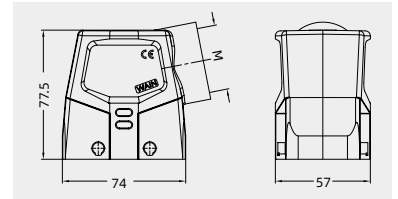

Hoods, side entry, high construction



Thread	Designation	Order No.
M40	HM10B.P-SEHH-4B-M40/30A	129 110 530 5500

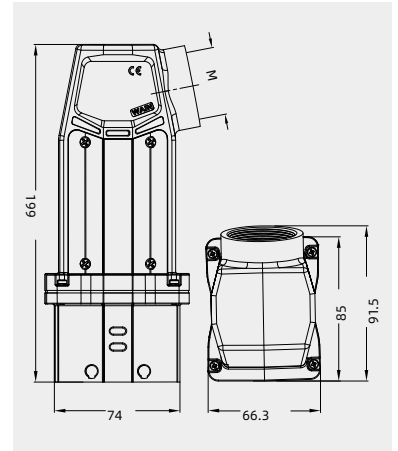

Please refer to page 28 for product

Hoods, top entry, high construction



Thread	Designation	Order No.
M32	HM10B.P-TEH-2L-M32	129 010 447 1500
M40	HM10B.P-TEH-2L-M40	129 010 440 5001

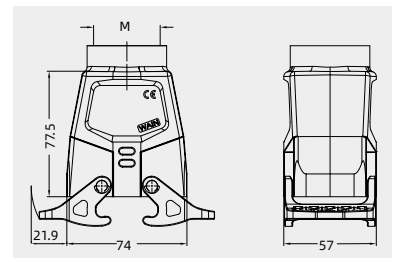

Hoods, side entry, high construction



Thread	Designation	Order No.
M32	HM10B.P-SEH-2L-M32	129 010 547 1500
M40	HM10B.P-SEH-2L-M40	129 010 540 5001

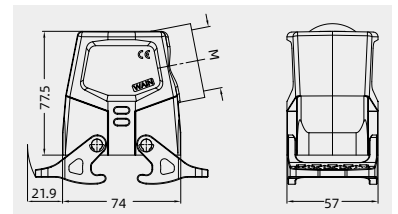

## 10B Modular type plastic hoods/housings

Degree of protection: IP65

Only suitable for HM series.

Number of modules: 4

## Bulkhead mounted housings



Thread	Designation	Order No.
---	HM10B.P-BK-2L	129 010 340 1001

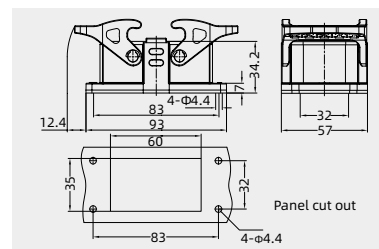

## Bulkhead mounted housings



Thread	Designation	Order No.
---	HM10B.P-BK-4B	129 010 330 1001

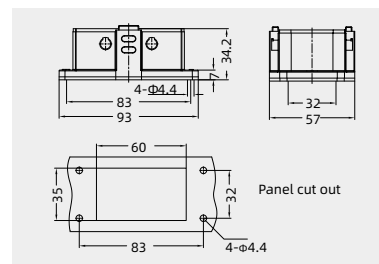

## Protection covers, for housings



Connect way	Designation	Order No.
	HM10B.P-CV-4B/2	129 110 000 8500

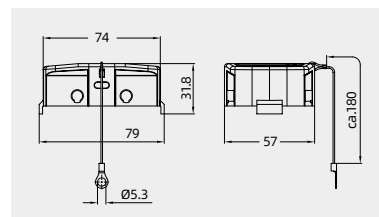

## Protection covers, for hoods



Connect way	Designation	Order No.
	HM10B.P-CV-2L/1	129 010 047 8500

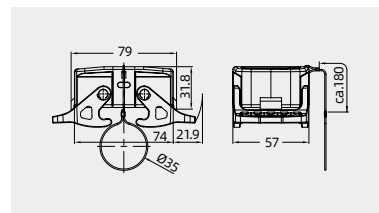

## 10B Metal hoods/housings

Degree of protection: IP65

## Hoods, side entry



Thread	Designation	Order No.
M20	H10B-SE-2B-M20	111 010 515 1002
M25	H10B-SE-2B-M25	111 010 515 1003
PG16	H10B-SE-2B-PG16	111 010 515 1010

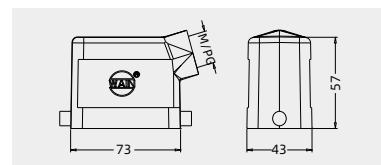

## Hoods, side entry, high construction



Thread	Designation	Order No.
---	W10B-BEH-2B	111 110 910 5001
M25	W10B-SEH-2B-M25	111 110 510 5001
M32	W10B-SEH-2B-M32	111 110 510 5002
PG21	W10B-SEH-2B-PG21	111 110 510 5003
PG29	W10B-SEH-2B-PG29	111 110 510 5004
with sleeve		
M25	W10B-SEH-2B-M25 WS	111 110 515 5103
M32	W10B-SEH-2B-M32 WS	111 110 515 5104
PG21	W10B-SEH-2B-PG21 WS	111 110 515 5111
PG29	W10B-SEH-2B-PG29 WS	111 110 515 5112

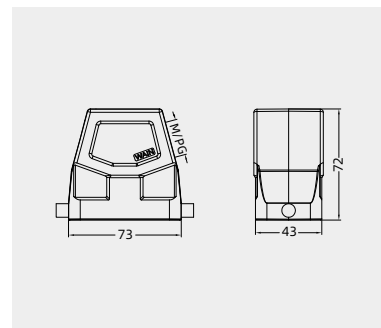

## Hoods, top entry



Thread	Designation	Order No.
M20	H10B-TE-2B-M20	111 010 415 1002
M25	H10B-TE-2B-M25	111 010 415 1003
PG16	H10B-TE-2B-PG16	111 010 415 1010

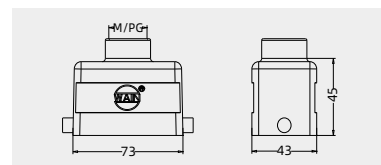

## Hoods, top entry, high construction



Thread	Designation	Order No.
---	W10B-BEH-2B	111 110 910 5001
M25	W10B-TEH-2B-M25	111 110 410 5001
M32	W10B-TEH-2B-M32	111 110 410 5002
PG21	W10B-TEH-2B-PG21	111 110 410 5003
PG29	W10B-TEH-2B-PG29	111 110 410 5004
with sleeve		
M25	W10B-TEH-2B-M25 WS	111 110 415 5103
M32	W10B-TEH-2B-M32 WS	111 110 415 5104
PG21	W10B-TEH-2B-PG21 WS	111 110 415 5111
PG29	W10B-TEH-2B-PG29 WS	111 110 415 5112

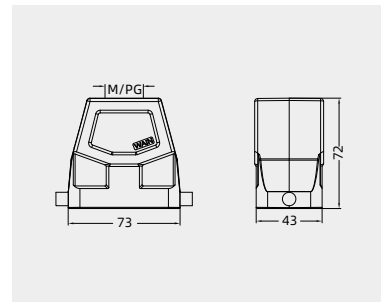

## Housings, cable to cable



Thread	Designation	Order No.
M20	H10B-CCT-1L/SC-M20	111 010 721 1002
M25	H10B-CCT-1L/SC-M25	111 010 721 1003
PG16	H10B-CCT-1L/SC-PG16	111 010 721 1010

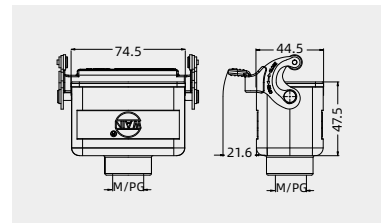

Please refer to page 15-02 for choosing proper model of lock.

## Housings, cable to cable, high construction



Thread	Designation	Order No.
M25	W10B-CCTH-1L/SC-M25	111 110 721 5001
M32	W10B-CCTH-1L/SC-M32	111 110 721 5002
PG21	W10B-CCTH-1L/SC-PG21	111 110 721 5003
PG29	W10B-CCTH-1L/SC-PG29	111 110 721 5004
with sleeve		
M25	W10B-CCTH-1L/SC-M25 WS	111 110 721 5103
M32	W10B-CCTH-1L/SC-M32 WS	111 110 721 5104
PG21	W10B-CCTH-1L/SC-PG21 WS	111 110 721 5111
PG29	W10B-CCTH-1L/SC-PG29 WS	111 110 721 5112

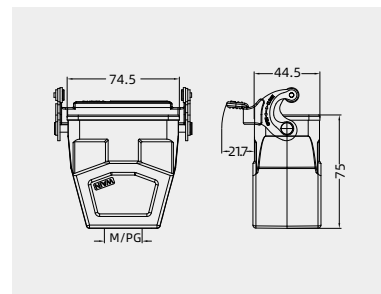

Please refer to page 15-02 for choosing proper model of lock.

10B Metal hoods/housings

Degree of protection: IP65

Bulkhead mounted housings



Thread	Designation	Order No.
---	H10B-BK-SE-1L/SC(82-68-4.5)	111 010 921 1001
---	H10B-BK-SE-1L/SC(82-70-4.5)	111 010 921 1002
---	H10B-BK-SE-1L/SC(85-73-4.5)	111 010 921 1003
---	H10B-BK-SE-1L/SC(85-73-5.5)	111 010 921 1004
---	H10B-BK-SE-1L/SC(92-70-4.1)	111 010 921 1005
---	H10B-BK-SE-1L/SC(92-70-4.3)	111 010 921 1006
---	H10B-BK-SE-1L/SC(92-77-4.3)	111 010 921 1007
---	H10B-BK-SE-1L/SC(92-80-5.1)	111 010 921 1008
---	H10B-BK-SE-1L/SC(98-68-4.5)	111 010 921 1009
---	H10B-BK-SE-1L/SC(98-70-4.3)	111 010 921 1010

Please refer to page 15-02 for choosing proper model of lock.

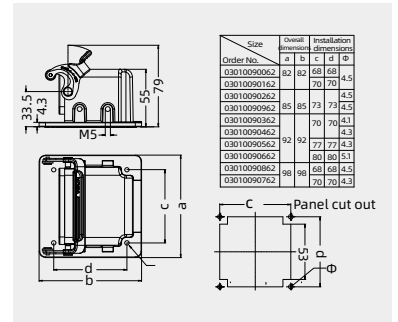

Bulkhead mounted housings



Thread	Designation	Order No.
---	H10B-BK-1L/SC	111 010 321 1001
---	with plastic cover	
---	H10B-BK-1L/SC-CV	111 010 361 1001
---	with metal cover	
---	H10B-BK-1L/SC-MCV	111 010 361 1101

Please refer to page 15-02 for choosing proper model of lock.

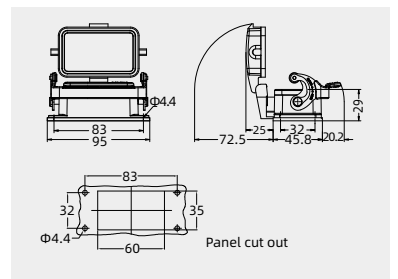

BK hole cover plate



Applications	Designation	Order No.
---	10B-BK/MCV	111 010 390 8001

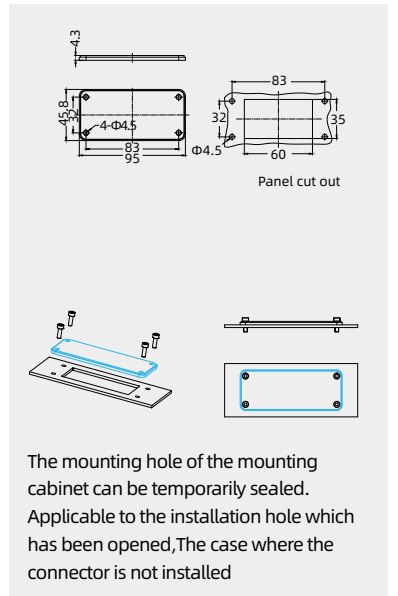

10B Metal hoods/housings

Degree of protection: IP65

Surface mounted housings

Structure 1



Thread	Designation	Order No.
M20	H10B-SF-1L/SC-M20	111 010 221 1002
2M20	H10B-SF-1L/SC-2M20	111 010 221 1022
M25	H10B-SF-1L/SC-M25 <sup>1)</sup>	111 010 221 1003
2M25	H10B-SF-1L/SC-2M25 <sup>1)</sup>	111 010 221 1023
PG16	H10B-SF-1L/SC-PG16	111 010 221 1010
2PG16	H10B-SF-1L/SC-2PG16	111 010 221 1030

with plastic cover

M20	H10B-SF-1L/SC-CV-M20	111 010 261 1002
2M20	H10B-SF-1L/SC-CV-2M20	111 010 261 1022
M25	H10B-SF-1L/SC-CV-M25 <sup>1)</sup>	111 010 261 1003
2M25	H10B-SF-1L/SC-CV-2M25 <sup>1)</sup>	111 010 261 1023
PG16	H10B-SF-1L/SC-CV-PG16	111 010 261 1010
2PG16	H10B-SF-1L/SC-CV-2PG16	111 010 261 1030

with metal cover

M20	H10B-SF-1L/SC-MCV-M20	111 010 261 1102
2M20	H10B-SF-1L/SC-MCV-2M20	111 010 261 1122
M25	H10B-SF-1L/SC-MCV-M25 <sup>1)</sup>	111 010 261 1103
2M25	H10B-SF-1L/SC-MCV-2M25 <sup>1)</sup>	111 010 261 1123
PG16	H10B-SF-1L/SC-MCV-PG16	111 010 261 1110
2PG16	H10B-SF-1L/SC-MCV-2PG16	111 010 261 1130

Please refer to page 15-02 for choosing proper model of lock.

Structure 2

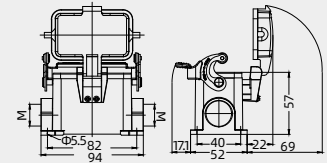

1) : Structure 1 ( M=M25 Using Structure 1)

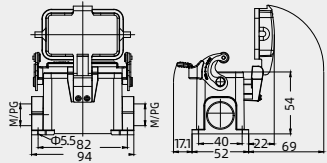

Structure 2: M/PG=M20/PG16 Using Structure 2

Surface mounted housings, high construction



Thread	Designation	Order No.
M25	H10B-SFH-1L/SC-M25	111 010 221 5003
2M25	H10B-SFH-1L/SC-2M25	111 010 221 5023
M32	H10B-SFH-1L/SC-M32	111 010 221 5004
2M32	H10B-SFH-1L/SC-2M32	111 010 221 5024
PG21	H10B-SFH-1L/SC-PG21	111 010 221 5011
2PG21	H10B-SFH-1L/SC-2PG21	111 010 221 5031
PG29	H10B-SFH-1L/SC-PG29	111 010 221 5012
2PG29	H10B-SFH-1L/SC-2PG29	111 010 221 5032

with plastic cover

M25	H10B-SFH-1L/SC-CV-M25	111 010 261 5003
2M25	H10B-SFH-1L/SC-CV-2M25	111 010 261 5023
M32	H10B-SFH-1L/SC-CV-M32	111 010 261 5004
2M32	H10B-SFH-1L/SC-CV-2M32	111 010 261 5024
PG21	H10B-SFH-1L/SC-CV-PG21	111 010 261 5011
2PG21	H10B-SFH-1L/SC-CV-2PG21	111 010 261 5031
PG29	H10B-SFH-1L/SC-CV-PG29	111 010 261 5012
2PG29	H10B-SFH-1L/SC-CV-2PG29	111 010 261 5032

with metal cover

M25	H10B-SFH-1L/SC-MCV-M25	111 010 261 5103
2M25	H10B-SFH-1L/SC-MCV-2M25	111 010 261 5123
M32	H10B-SFH-1L/SC-MCV-M32	111 010 261 5104
2M32	H10B-SFH-1L/SC-MCV-2M32	111 010 261 5124
PG21	H10B-SFH-1L/SC-MCV-PG21	111 010 261 5111
2PG21	H10B-SFH-1L/SC-MCV-2PG21	111 010 261 5131
PG29	H10B-SFH-1L/SC-MCV-PG29	111 010 261 5112
2PG29	H10B-SFH-1L/SC-MCV-2PG29	111 010 261 5132

Please refer to page 15-02 for choosing proper model of lock.

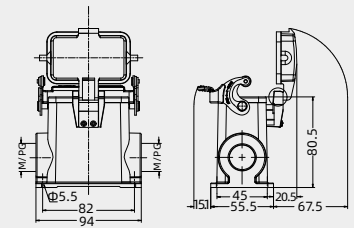

## 10B Metal hoods/housings

Degree of protection: IP65

## Hoods, side entry



Thread	Designation	Order No.
M20	H10B-SE-4B-M20	111 010 530 1002
M25	H10B-SE-4B-M25	111 010 530 1003
PG16	H10B-SE-4B-PG16	111 010 530 1010

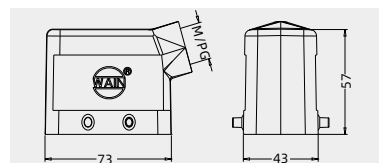

## Hoods, side entry, high construction



Thread	Designation	Order No.
---	W10B-BEH-4B	111 110 930 5003
M25	W10B-SEH-4B-M25	111 110 530 5001
M32	W10B-SEH-4B-M32	111 110 530 5002
PG21	W10B-SEH-4B-PG21	111 110 530 5003
PG29	W10B-SEH-4B-PG29	111 110 530 5004
M25	W10B-SEH-4B-M25 WS	111 110 530 5103
M32	W10B-SEH-4B-M32 WS	111 110 530 5104
PG21	W10B-SEH-4B-PG21 WS	111 110 530 5111
PG29	W10B-SEH-4B-PG29 WS	111 110 530 5112

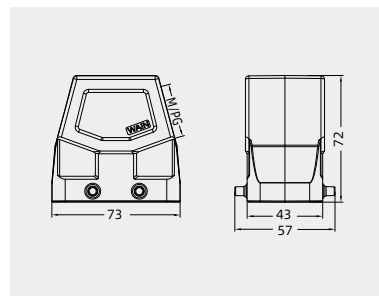

## Hoods, top entry



Thread	Designation	Order No.
M20	H10B-TE-4B-M20	111 010 430 1002
M25	H10B-TE-4B-M25	111 010 430 1003
PG16	H10B-TE-4B-PG16	111 010 430 1010

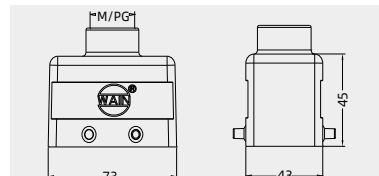

## Hoods, top entry, high construction



Thread	Designation	Order No.
---	W10B-BEH-4B	111 110 930 5003
M25	W10B-TEH-4B-M25	111 110 430 5001
M32	W10B-TEH-4B-M32	111 110 430 5004
PG21	W10B-TEH-4B-PG21	111 110 430 5005
PG29	W10B-TEH-4B-PG29	111 110 430 5006
M25	W10B-TEH-4B-M25 WS	111 110 430 5103
M32	W10B-TEH-4B-M32 WS	111 110 430 5104
PG21	W10B-TEH-4B-PG21 WS	111 110 430 5111
PG29	W10B-TEH-4B-PG29 WS	111 110 430 5112

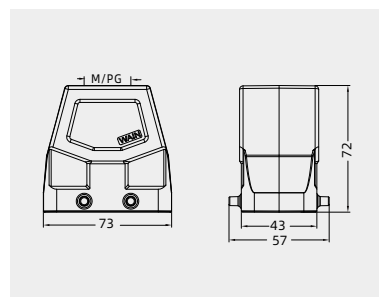

## Bulkhead mounted housings



Thread	Designation	Order No.
---	H10B-BK-2L/SC	111 010 341 1001

Please refer to page 15-02 for choosing proper model of lock.

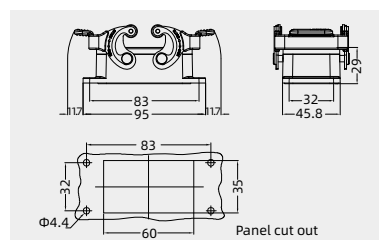

## Surface mounted housings

## Structure 1



Thread	Designation	Order No.
M20	H10B-SF-2L/SC-M20	111 010 241 1002
2M20	H10B-SF-2L/SC-2M20	111 010 241 1022
M25	H10B-SF-2L/SC-M25 <sup>1)</sup>	111 010 241 1003
2M25	H10B-SF-2L/SC-2M25 <sup>1)</sup>	111 010 241 1023
PG16	H10B-SF-2L/SC-PG16	111 010 241 1010
2PG16	H10B-SF-2L/SC-2PG16	111 010 241 1030

## Structure 2



Please refer to page 15-02 for choosing proper model of lock.

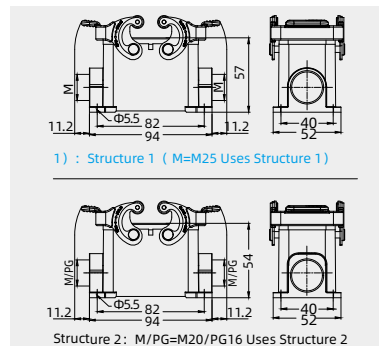

## 10B Metal hoods/housings

Degree of protection: IP65

Surface mounted housings, high construction



Thread	Designation	Order No.
M25	H10B-SFH-2L/SC-M25	111 010 241 5003
2M25	H10B-SFH-2L/SC-2M25	111 010 241 5023
M32	H10B-SFH-2L/SC-M32	111 010 241 5004
2M32	H10B-SFH-2L/SC-2M32	111 010 241 5024
PG21	H10B-SFH-2L/SC-PG21	111 010 241 5011
2PG21	H10B-SFH-2L/SC-2PG21	111 010 241 5031
PG29	H10B-SFH-2L/SC-PG29	111 010 241 5012
2PG29	H10B-SFH-2L/SC-2PG29	111 010 241 5032

Please refer to page 15-02 for choosing proper model of lock.

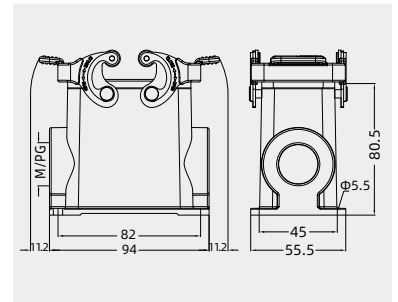

Housings, cable to cable



Thread	Designation	Order No.
M20	H10B-CCT-2L/SC-M20	111 010 741 1002
M25	H10B-CCT-2L/SC-M25	111 010 741 1003
PG16	H10B-CCT-2L/SC-PG16	111 010 741 1010

Please refer to page 15-02 for choosing proper model of lock.

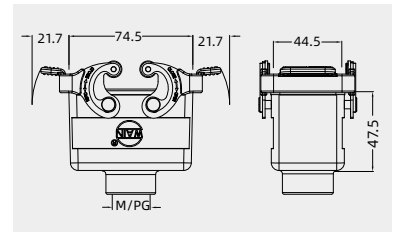

Housings, cable to cable, high construction



Thread	Designation	Order No.
M25	W10B-CCTH-2L/SC-M25	111 110 741 5001
M32	W10B-CCTH-2L/SC-M32	111 110 741 5002
PG21	W10B-CCTH-2L/SC-PG21	111 110 741 5003
PG29	W10B-CCTH-2L/SC-PG29 with sleeve	111 110 741 5004
M25	W10B-CCTH-2L/SC-M25 WS	111 110 741 5103
M32	W10B-CCTH-2L/SC-M32 WS	111 110 741 5104
PG21	W10B-CCTH-2L/SC-PG21 WS	111 110 741 5111
PG29	W10B-CCTH-2L/SC-PG29 WS	111 110 741 5112

Please refer to page 15-02 for choosing proper model of lock.

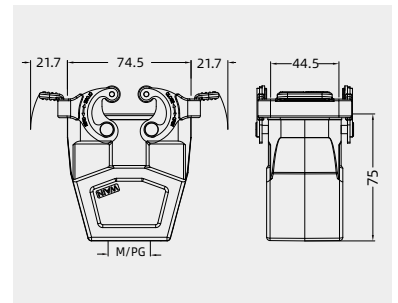

Protection covers, plastic



Connect way	Applications	Designation	Order No.
---	for hoods	H10B-CV-4C	111 010 090 8009

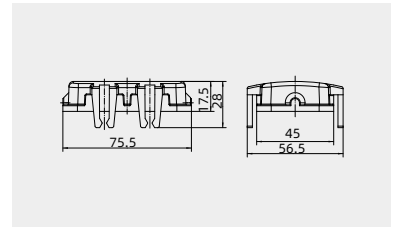

Protection covers, plastic



Connect way	Applications	Designation	Order No.
	for Housings, cable to cable	H10B-CV-4B/1	111 010 030 8001
	for Housings, bulkhead mounting / surface mounting	H10B-CV-4B/2	111 010 030 8002

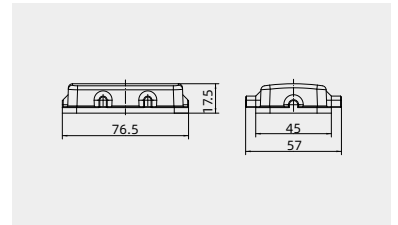



## 10B Metal hoods/housings

Degree of protection: IP65

## Hoods, side entry



Thread	Designation	Order No.
M20	H10B-SE-2L/SC-M20	111 010 541 1002
M25	H10B-SE-2L/SC-M25	111 010 514 1003
PG16	H10B-SE-2L/SC-PG16	111 010 541 1010

Please refer to page 15-02 for choosing proper model of lock.

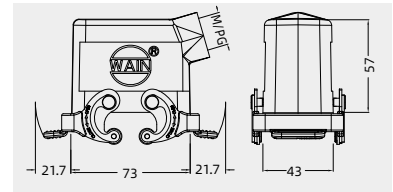

## Hoods, side entry, high construction



Thread	Designation	Order No.
M25	W10B-SEH-2L/SC-M25	111 110 541 5001
M32	W10B-SEH-2L/SC-M32	111 110 541 5002
PG21	W10B-SEH-2L/SC-PG21	111 110 541 5003
PG29	W10B-SEH-2L/SC-PG29	111 110 541 5004
	with sleeve	
M25	W10B-SEH-2L/SC-M25 WS	111 110 541 5103
M32	W10B-SEH-2L/SC-M32 WS	111 110 541 5104
PG21	W10B-SEH-2L/SC-PG21 WS	111 110 541 5111
PG29	W10B-SEH-2L/SC-PG29 WS	111 110 541 5112

Please refer to page 15-02 for choosing proper model of lock.

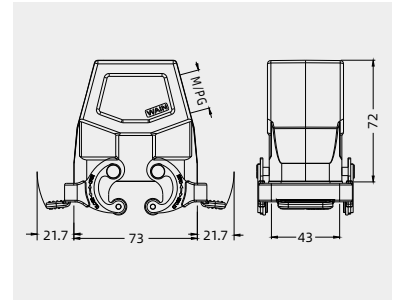

## Hoods, top entry



Thread	Designation	Order No.
M20	H10B-TE-2L/SC-M20	111 010 441 1002
M25	H10B-TE-2L/SC-M25	111 010 414 1003
PG16	H10B-TE-2L/SC-PG16	111 010 441 1010

Please refer to page 15-02 for choosing proper model of lock.

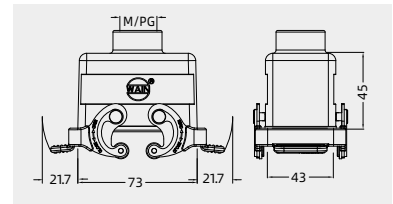

## Hoods, top entry, high construction



Thread	Designation	Order No.
M25	W10B-TEH-2L/SC-M25	111 110 441 5001
M32	W10B-TEH-2L/SC-M32	111 110 441 5002
PG21	W10B-TEH-2L/SC-PG21	111 110 441 5003
PG29	W10B-TEH-2L/SC-PG29	111 110 441 5004
	with sleeve	
M25	W10B-TEH-2L/SC-M25 WS	111 110 441 5103
M32	W10B-TEH-2L/SC-M32 WS	111 110 441 5104
PG21	W10B-TEH-2L/SC-PG21 WS	111 110 441 5111
PG29	W10B-TEH-2L/SC-PG29 WS	111 110 441 5112

Please refer to page 15-02 for choosing proper model of lock.

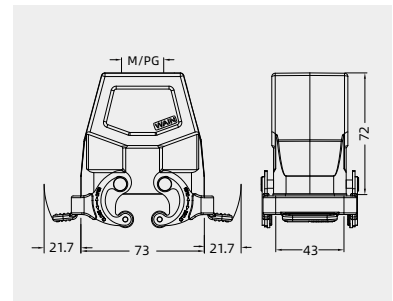

## Bulkhead mounted housings



Thread	Designation	Order No.
---	H10B-BK-4B	111 010 330 1001
	with plastic cover	
---	H10B-BK-4B-CV	111 010 370 1001
	with metal cover	
---	H10B-BK-4B-MCV	111 010 370 1101

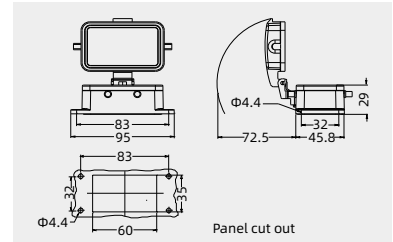

10B Metal hoods/housings

Degree of protection: IP65

Surface mounted housings

Structure 1



Thread	Designation	Order No.
M20	H10B-SF-4B-M20	111 010 230 1002
2M20	H10B-SF-4B-2M20	111 010 230 1022
M25	H10B-SF-4B-M25 <sup>1)</sup>	111 010 230 1003
2M25	H10B-SF-4B-2M25 <sup>1)</sup>	111 010 230 1023
PG16	H10B-SF-4B-PG16	111 010 230 1010
2PG16	H10B-SF-4B-2PG16	111 010 230 1030

with plastic cover		
M20	H10B-SF-4B-CV-M20	111 010 270 1002
2M20	H10B-SF-4B-CV-2M20	111 010 270 1022
M25	H10B-SF-4B-CV-M25 <sup>1)</sup>	111 010 270 1003
2M25	H10B-SF-4B-CV-2M25 <sup>1)</sup>	111 010 270 1023
PG16	H10B-SF-4B-CV-PG16	111 010 270 1010
2PG16	H10B-SF-4B-CV-2PG16	111 010 270 1030

Structure 2



with metal cover		
M20	H10B-SF-4B-MCV-M20	111 010 270 1102
2M20	H10B-SF-4B-MCV-2M20	111 010 270 1122
M25	H10B-SF-4B-MCV-M25 <sup>1)</sup>	111 010 270 1103
2M25	H10B-SF-4B-MCV-2M25 <sup>1)</sup>	111 010 270 1123
PG16	H10B-SF-4B-MCV-PG16	111 010 270 1110
2PG16	H10B-SF-4B-MCV-2PG16	111 010 270 1130

Surface mounted housings, high construction



Thread	Designation	Order No.
M25	H10B-SFH-4B-M25	111 010 230 5003
2M25	H10B-SFH-4B-2M25	111 010 230 5023
M32	H10B-SFH-4B-M32	111 010 230 5004
2M32	H10B-SFH-4B-2M32	111 010 230 5024
PG21	H10B-SFH-4B-PG21	111 010 230 5011
2PG21	H10B-SFH-4B-2PG21	111 010 230 5031
PG29	H10B-SFH-4B-PG29	111 010 230 5012
2PG29	H10B-SFH-4B-2PG29	111 010 230 5032

with plastic cover		
M25	H10B-SFH-4B-CV-M25	111 010 270 5003
2M25	H10B-SFH-4B-CV-2M25	111 010 270 5023
M32	H10B-SFH-4B-CV-M32	111 010 270 5004
2M32	H10B-SFH-4B-CV-2M32	111 010 270 5024
PG21	H10B-SFH-4B-CV-PG21	111 010 270 5011
2PG21	H10B-SFH-4B-CV-2PG21	111 010 270 5031
PG29	H10B-SFH-4B-CV-PG29	111 010 270 5012
2PG29	H10B-SFH-4B-CV-2PG29	111 010 270 5032

with metal cover		
M25	H10B-SFH-4B-MCV-M25	111 010 270 5103
2M25	H10B-SFH-4B-MCV-2M25	111 010 270 5123
M32	H10B-SFH-4B-MCV-M32	111 010 270 5104
2M32	H10B-SFH-4B-MCV-2M32	111 010 270 5124
PG21	H10B-SFH-4B-MCV-PG21	111 010 270 5111
2PG21	H10B-SFH-4B-MCV-2PG21	111 010 270 5131
PG29	H10B-SFH-4B-MCV-PG29	111 010 270 5112
2PG29	H10B-SFH-4B-MCV-2PG29	111 010 270 5132

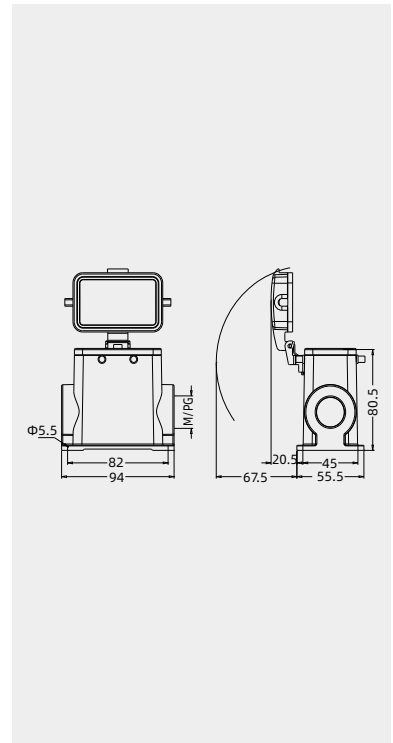
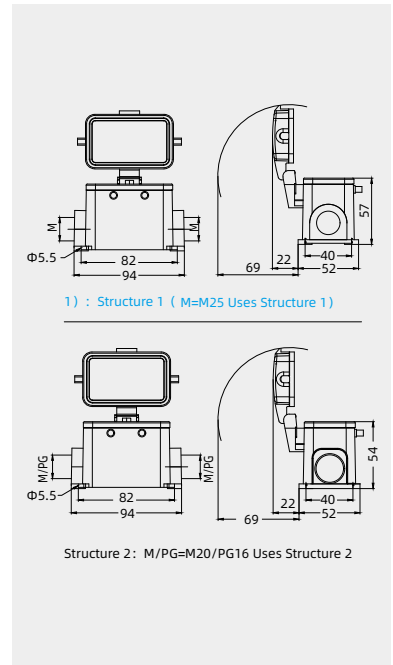

# 10B Metal hoods/housings

Degree of protection: IP65

Protection covers, metal



Connect way	Application	Designation	Order No.
	for hoods	H10B-MCV-4B/1S	111 010 030 8103
	for housings, without sealing	H10B-MCV-4B/2	111 010 030 8102

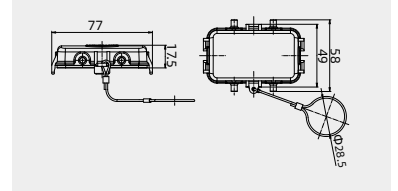

Protection covers, metal



Connect way	Application	Designation	Order No.
	for hoods	H10B-MCV-2L/SC.1S	111 010 041 8101
	for housings	H10B-MCV-2L/SC.2	111 010 041 8102

Please refer to page 15-02 for choosing proper model of lock.

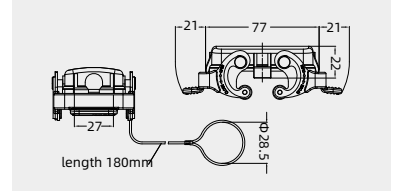

10B Metal hoods/housings

Degree of protection: IP65

Protection covers, metal



Connect way	Applications	Designation	Order No.
	for hoods	H10B-MCV-1L/SC.1S	111 010 021 8001

Please refer to page 15-02 for choosing proper model of lock.

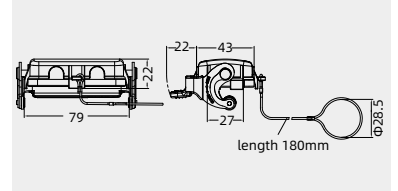

Protection covers(IP5X)



Thread	Applications	Designation	Order No.
---	for housings	H10B-CV/C	111 010 000 8002

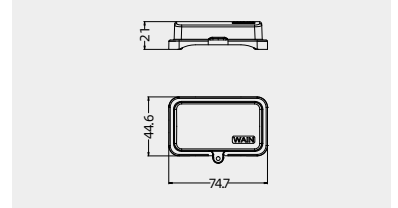

H

Hoods, side entry, high construction



Thread	Designation	Order No.
M25	W10B-SEH-1L/C-M25	111 110 550 5002
M32	W10B-SEH-1L/C-M32	111 110 550 5001

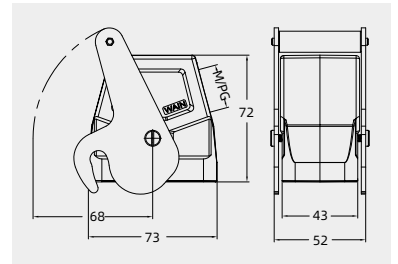

Bulkhead mounted housings



Thread	Designation	Order No.
---	H10B-BK-2B/C	111 010 350 1001

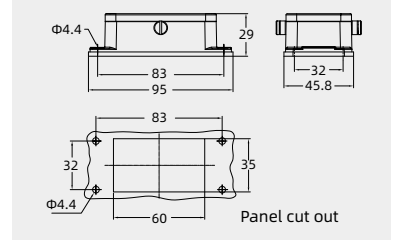

10B Metal hoods/housings  
-Suitable for harsh environment(anti-corrosion)

Degree of protection: IP65

Hoods, side entry



Thread	Designation	Order No.
M20	H10B-MSE-4B-M20	112 010 530 1002
M25	H10B-MSE-4B-M25	112 010 530 1003
PG16	H10B-MSE-4B-PG16	112 010 530 1010

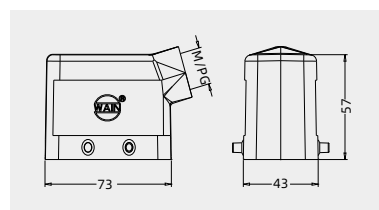

Hoods, side entry, high construction



Thread	Designation	Order No.
M25	W10B-MSEH-4B-M25	112 110 530 5001
M32	W10B-MSEH-4B-M32	112 110 530 5007
PG21	W10B-MSEH-4B-PG21	112 110 530 5011
PG29	W10B-MSEH-4B-PG29	112 110 530 5012

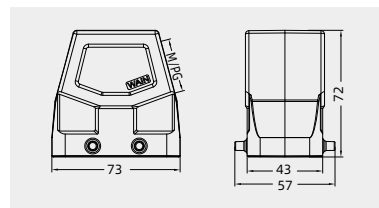

Hoods, top entry



Thread	Designation	Order No.
M20	H10B-MTE-4B-M20	112 010 430 1002
M25	H10B-MTE-4B-M25	112 010 430 1003
PG16	H10B-MTE-4B-PG16	112 010 430 1010

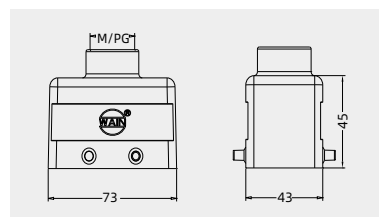

Hoods, top entry, high construction



Thread	Designation	Order No.
M25	W10B-MTEH-4B-M25	112 110 430 5003
M32	W10B-MTEH-4B-M32	112 110 430 5001
PG21	W10B-MTEH-4B-PG21	112 110 430 5011
PG29	W10B-MTEH-4B-PG29	112 110 430 5012

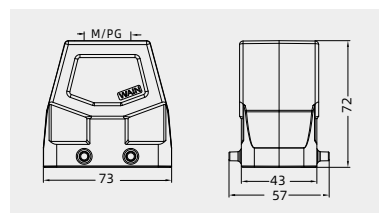

Housings, cable to cable



Thread	Designation	Order No.
M20	H10B-MCCT-2L/SC-M20	112 010 741 1002
M25	H10B-MCCT-2L/SC-M25	112 010 741 1003
PG16	H10B-MCCT-2L/SC-PG16	112 010 741 1010

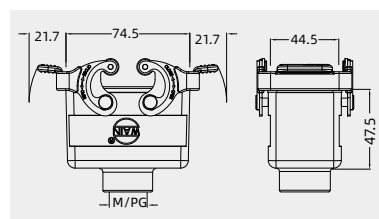

Bulkhead mounted housings



Thread	Designation	Order No.
---	H10B-MBK-2L/SC	112 010 341 1001

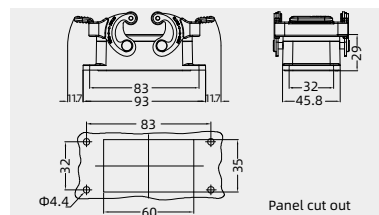

## 10B Metal hoods/housings -Suitable for harsh environment(anti-corrosion)

Degree of protection: IP65

### Hoods, side entry

#### Structure 1



Thread	Designation	Order No.
M20	H10B-MSF-2L/SC-M20	112 010 241 1002
2M20	H10B-MSF-2L/SC-2M20	112 010 241 1022
M25	H10B-MSF-2L/SC-M25 <sup>1)</sup>	112 010 241 1003
2M25	H10B-MSF-2L/SC-2M25 <sup>1)</sup>	112 010 241 1023
PG16	H10B-MSF-2L/SC-PG16	112 010 241 1010
2PG16	H10B-MSF-2L/SC-2PG16	112 010 241 1030

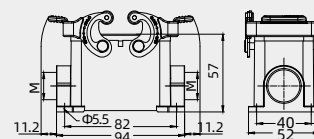

1) : Structure 1 ( M=M25 Uses Structure 1)

#### Structure 2

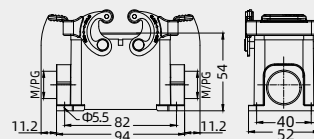

Structure 2: M/PG=M20/PG16 Uses Structure 2

### Hoods, side entry, high construction



Thread	Designation	Order No.
M25	H10B-MSFH-2L/SC-M25	112 010 241 5003
2M25	H10B-MSFH-2L/SC-2M25	112 010 241 5023
M32	H10B-MSFH-2L/SC-M32	112 010 241 5004
2M32	H10B-MSFH-2L/SC-2M32	112 010 241 5024
PG21	H10B-MSFH-2L/SC-PG21	112 010 241 5011
2PG21	H10B-MSFH-2L/SC-2PG21	112 010 241 5031
PG29	H10B-MSFH-2L/SC-PG29	112 010 241 5012
2PG29	H10B-MSFH-2L/SC-2PG29	112 010 241 5032

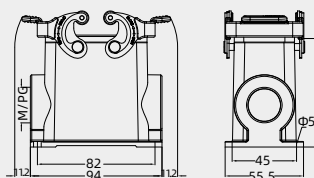

### Protection covers



Connect way	Designation	Order No.
	H10B-MMCV-2L/SC.1S	112 010 041 8001

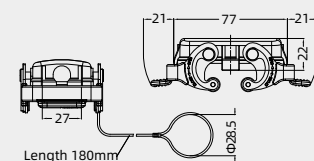

### Protection covers



Connect way	Designation	Order No.
	H10B-MMCV-4B/2	112 010 030 8002

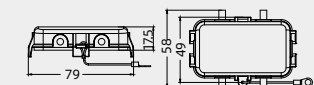

## 10B Metal hoods/housings

Degree of protection: IP67

## Hoods, side entry



Thread	Designation	Order No.
M20	W10B-SE-2B-M20	111 110 510 1001
M25	W10B-SE-2B-M25	111 110 510 1002
PG16	W10B-SE-2B-PG16	111 110 510 1003

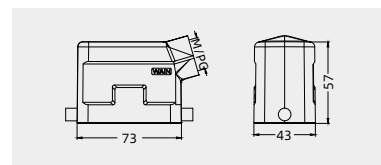

## Hoods, side entry, high construction



Thread	Designation	Order No.
---	W10B-BEH-2B	111 110 910 5001
M25	W10B-SEH-2B-M25	111 110 510 5001
M32	W10B-SEH-2B-M32	111 110 510 5002
PG21	W10B-SEH-2B-PG21	111 110 510 5003
PG29	W10B-SEH-2B-PG29	111 110 510 5004
	with sleeve	
M25	W10B-SEH-2B-M25 WS	111 110 515 5103
M32	W10B-SEH-2B-M32 WS	111 110 515 5104
PG21	W10B-SEH-2B-PG21 WS	111 110 515 5111
PG29	W10B-SEH-2B-PG29 WS	111 110 515 5112

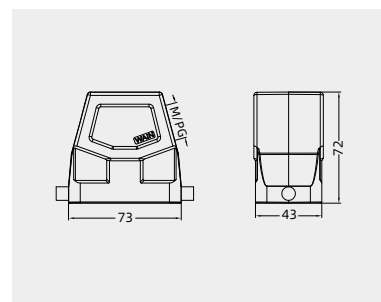

## Hoods, top entry



Thread	Designation	Order No.
M20	W10B-TE-2B-M20	111 110 410 1001
M25	W10B-TE-2B-M25	111 110 410 1002
PG16	W10B-TE-2B-PG16	111 110 410 1003

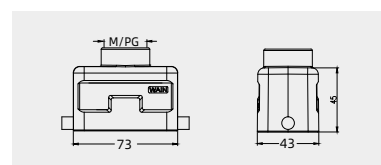

## Hoods, top entry, high construction



Thread	Designation	Order No.
---	W10B-BEH-2B	111 110 910 5001
M25	W10B-TEH-2B-M25	111 110 410 5001
M32	W10B-TEH-2B-M32	111 110 410 5002
PG21	W10B-TEH-2B-PG21	111 110 410 5003
PG29	W10B-TEH-2B-PG29	111 110 410 5004
	with sleeve	
M25	W10B-TEH-2B-M25 WS	111 110 415 5103
M32	W10B-TEH-2B-M32 WS	111 110 415 5104
PG21	W10B-TEH-2B-PG21 WS	111 110 415 5111
PG29	W10B-TEH-2B-PG29 WS	111 110 415 5112

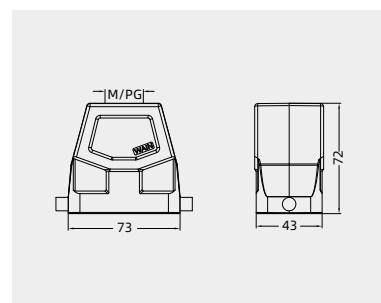

## 10B Metal hoods/housings

Degree of protection: IP67

## Housings, cable to cable



Thread	Designation	Order No.
M20	W10B-CCT-1L/SC-M20	111 110 721 1002
M25	W10B-CCT-1L/SC-M25	111 110 721 1003
PG16	W10B-CCT-1L/SC-PG16	111 110 721 1004

Please refer to page 15-02 for choosing proper model of lock.

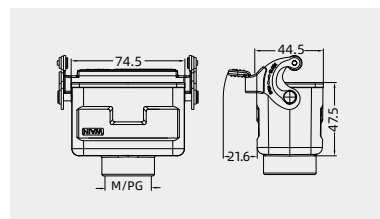
Housings, cable to cable,  
high construction

Thread	Designation	Order No.
M25	W10B-CCTH-1L/SC-M25	111 110 721 5001
M32	W10B-CCTH-1L/SC-M32	111 110 721 5002
PG21	W10B-CCTH-1L/SC-PG21	111 110 721 5003
PG29	W10B-CCTH-1L/SC-PG29	111 110 721 5004
	with sleeve	
M25	W10B-CCTH-1L/SC-M25 WS	111 110 721 5103
M32	W10B-CCTH-1L/SC-M32 WS	111 110 721 5104
PG21	W10B-CCTH-1L/SC-PG21 WS	111 110 721 5111
PG29	W10B-CCTH-1L/SC-PG29 WS	111 110 721 5112

Please refer to page 15-02 for choosing proper model of lock.

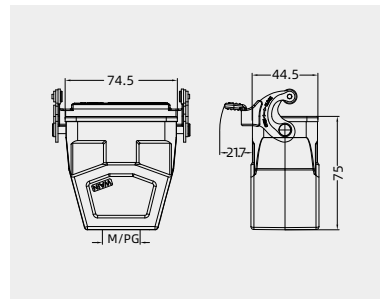

## Bulkhead mounted housings



Thread	Designation	Order No.
---	W10B-BK-1L/SC with plastic cover	111 110 321 1001
---	W10B-BK-1L/SC-CV with metal cover	111 110 321 8001
---	W10B-BK-1L/SC-MCV	111 110 321 8002

Please refer to page 15-02 for choosing proper model of lock.

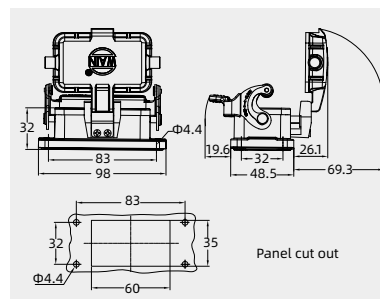



## 10B Metal hoods/housings

Degree of protection: IP67

## Hoods, side entry



Thread	Designation	Order No.
M20	W10B-SE-4B-M20	111 110 530 1005
M25	W10B-SE-4B-M25	111 110 530 1006
PG16	W10B-SE-4B-PG16	111 110 530 1007

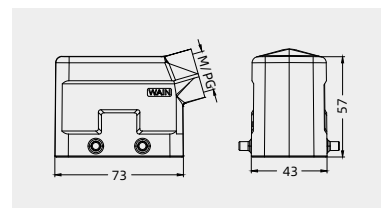

## Hoods, side entry, high construction



Thread	Designation	Order No.
---	W10B-BEH-4B	111 110 930 5003
M25	W10B-SEH-4B-M25	111 110 530 5001
M32	W10B-SEH-4B-M32	111 110 530 5002
PG21	W10B-SEH-4B-PG21	111 110 530 5003
PG29	W10B-SEH-4B-PG29	111 110 530 5004
	with sleeve	
M25	W10B-SEH-4B-M25 <b>WS</b>	111 110 530 5103
M32	W10B-SEH-4B-M32 <b>WS</b>	111 110 530 5104
PG21	W10B-SEH-4B-PG21 <b>WS</b>	111 110 530 5111
PG29	W10B-SEH-4B-PG29 <b>WS</b>	111 110 530 5112

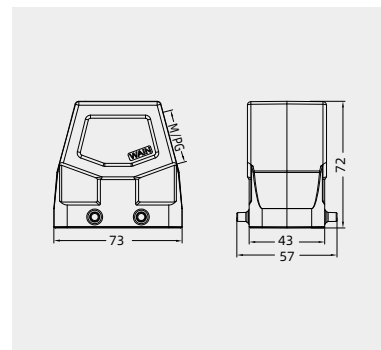

## Hoods, top entry



Thread	Designation	Order No.
M20	W10B-TE-4B-M20	111 110 430 1005
M25	W10B-TE-4B-M25	111 110 430 1006
PG16	W10B-TE-4B-PG16	111 110 430 1007

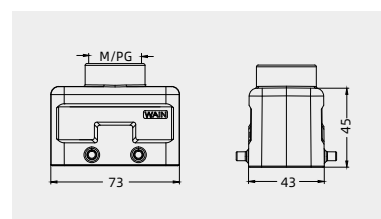

## Hoods, top entry, high construction



Thread	Designation	Order No.
---	W10B-BEH-4B	111 110 930 5003
M25	W10B-TEH-4B-M25	111 110 430 5001
M32	W10B-TEH-4B-M32	111 110 430 5004
PG21	W10B-TEH-4B-PG21	111 110 430 5005
PG29	W10B-TEH-4B-PG29	111 110 430 5006
	with sleeve	
M25	W10B-TEH-4B-M25 <b>WS</b>	111 110 430 5103
M32	W10B-TEH-4B-M32 <b>WS</b>	111 110 430 5104
PG21	W10B-TEH-4B-PG21 <b>WS</b>	111 110 430 5111
PG29	W10B-TEH-4B-PG29 <b>WS</b>	111 110 430 5112

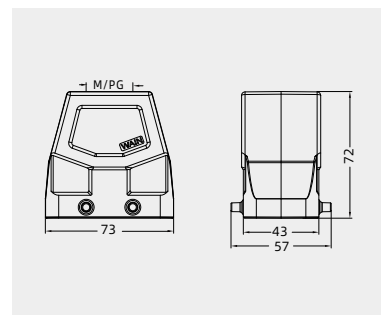

## Bulkhead mounted housings



Thread	Designation	Order No.
---	W10B-BK-2L/SC	111 110 341 1002

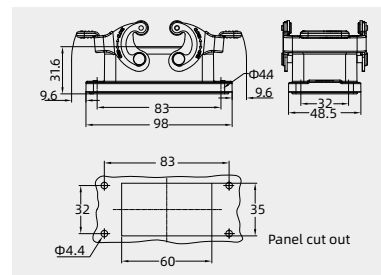

Please refer to page 15-02 for choosing proper model of lock.

## 10B Metal hoods/housings

Degree of protection: IP67

## Housings, cable to cable



Thread	Designation	Order No.
M20	W10B-CCT-2L/SC-M20	111 110 741 1002
M25	W10B-CCT-2L/SC-M25	111 110 741 1003
PG16	W10B-CCT-2L/SC-PG16	111 110 741 1004

Please refer to page 15-02 for choosing proper model of lock.

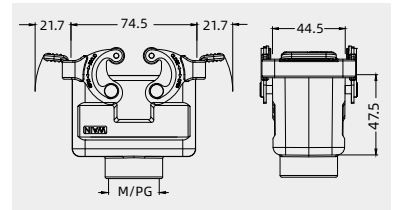

## Housings, cable to cable, high construction



Thread	Designation	Order No.
M25	W10B-CCTH-2L/SC-M25	111 110 741 5001
M32	W10B-CCTH-2L/SC-M32	111 110 741 5002
PG21	W10B-CCTH-2L/SC-PG21	111 110 741 5003
PG29	W10B-CCTH-2L/SC-PG29	111 110 741 5004
	with sleeve	
M25	W10B-CCTH-2L/SC-M25 WS	111 110 741 5103
M32	W10B-CCTH-2L/SC-M32 WS	111 110 741 5104
PG21	W10B-CCTH-2L/SC-PG21 WS	111 110 741 5111
PG29	W10B-CCTH-2L/SC-PG29 WS	111 110 741 5112

Please refer to page 15-02 for choosing proper model of lock.

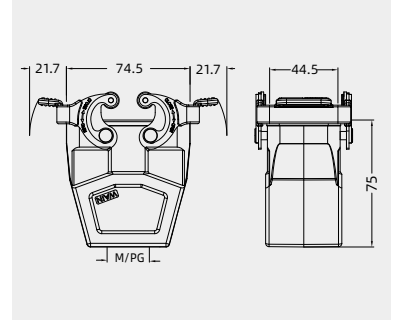

## 10B Metal hoods/housings

Degree of protection: IP67

## Hoods, side entry



Thread	Designation	Order No.
M20	W10B-SE-2L/SC-M20	111 110 541 1001
M25	W10B-SE-2L/SC-M25	111 110 541 1003
PG16	W10B-SE-2L/SC-PG16	111 110 541 1002

Please refer to page 15-02 for choosing proper model of lock.

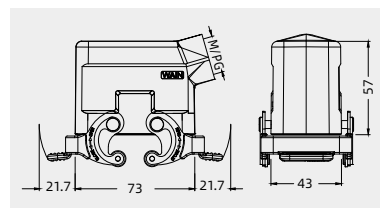

## Hoods, side entry, high construction



Thread	Designation	Order No.
M25	W10B-SEH-2L/SC-M25	111 110 541 5001
M32	W10B-SEH-2L/SC-M32	111 110 541 5002
PG21	W10B-SEH-2L/SC-PG21	111 110 541 5003
PG29	W10B-SEH-2L/SC-PG29	111 110 541 5004
	with sleeve	
M25	W10B-SEH-2L/SC-M25 WS	111 110 541 5103
M32	W10B-SEH-2L/SC-M32 WS	111 110 541 5104
PG21	W10B-SEH-2L/SC-PG21 WS	111 110 541 5111
PG29	W10B-SEH-2L/SC-PG29 WS	111 110 541 5112

Please refer to page 15-02 for choosing proper model of lock.

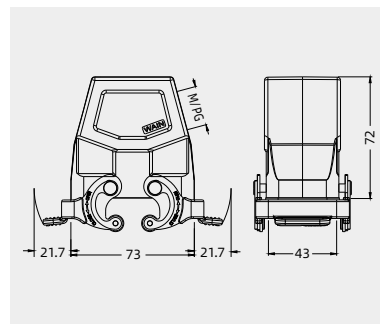

## Hoods, top entry



Thread	Designation	Order No.
M20	W10B-TE-2L/SC-M20	111 110 441 1001
M25	W10B-TE-2L/SC-M25	111 110 441 1003
PG16	W10B-TE-2L/SC-PG16	111 110 441 1002

Please refer to page 15-02 for choosing proper model of lock.

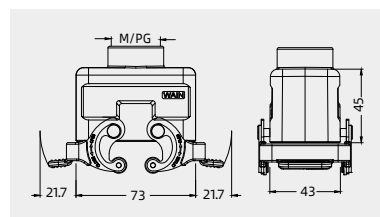

## Hoods, top entry, high construction



Thread	Designation	Order No.
M25	W10B-TEH-2L/SC-M25	111 110 441 5001
M32	W10B-TEH-2L/SC-M32	111 110 441 5002
PG21	W10B-TEH-2L/SC-PG21	111 110 441 5003
PG29	W10B-TEH-2L/SC-PG29	111 110 441 5004
	with sleeve	
M25	W10B-TEH-2L/SC-M25 WS	111 110 441 5103
M32	W10B-TEH-2L/SC-M32 WS	111 110 441 5104
PG21	W10B-TEH-2L/SC-PG21 WS	111 110 441 5111
PG29	W10B-TEH-2L/SC-PG29 WS	111 110 441 5112

Please refer to page 15-02 for choosing proper model of lock.

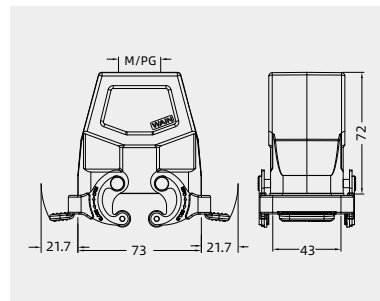

## Bulkhead mounted housings



Thread	Designation	Order No.
---	W10B-BK-4B	111 110 330 1001
---	W10B-BK-4B-CV	111 110 330 8001
---	W10B-BK-4B-MCV	111 110 330 8002

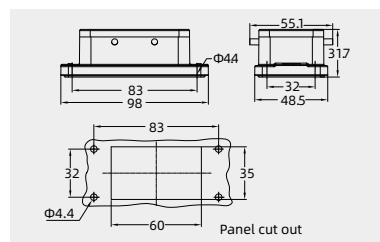

## 10B Metal hoods/housings

Degree of protection: IP67

Hoods, side entry, high construction



Thread	Designation	Order No.
M25	W10B-SEH-1L/C-M25	111 110 550 5002
M32	W10B-SEH-1L/C-M32	111 110 550 5001
PG21	W10B-SEH-1L/C-PG21	111 110 555 5001
PG29	W10B-SEH-1L/C-PG29	111 110 550 5003

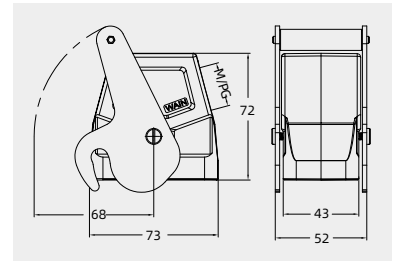

Bulkhead mounted housings



Thread	Designation	Order No.
---	W10B-BK-2B/C	111 110 350 1001

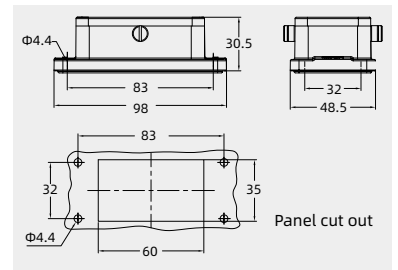

H

## 10B Metal hoods/housings -Suitable for harsh environment(anti-corrosion)

Degree of protection: IP67

### Hoods, side entry



Thread	Designation	Order No.
M20	W10B-MSE-4B-M20	112 110 530 1001
M25	W10B-MSE-4B-M25	112 110 530 1003
PG16	W10B-MSE-4B-PG16	112 110 530 1002

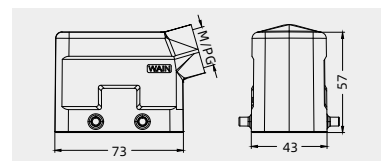

### Hoods, side entry, high construction



Thread	Designation	Order No.
M25	W10B-MSEH-4B-M25	112 110 530 5001
M32	W10B-MSEH-4B-M32	112 110 530 5007
PG21	W10B-MSEH-4B-PG21	112 110 530 5011
PG29	W10B-MSEH-4B-PG29	112 110 530 5012

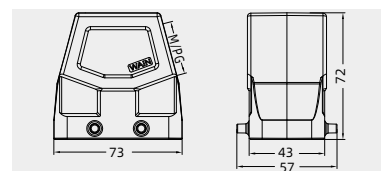

### Hoods, top entry



Thread	Designation	Order No.
M20	W10B-MTE-4B-M20	112 110 430 1001
M25	W10B-MTE-4B-M25	112 110 430 1003
PG16	W10B-MTE-4B-PG16	112 110 430 1002

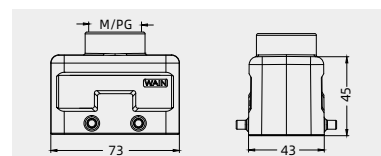

### Hoods, top entry, high construction



Thread	Designation	Order No.
M25	W10B-MTEH-4B-M25	112 110 430 5003
M32	W10B-MTEH-4B-M32	112 110 430 5001
PG21	W10B-MTEH-4B-PG21	112 110 430 5011
PG29	W10B-MTEH-4B-PG29	112 110 430 5012

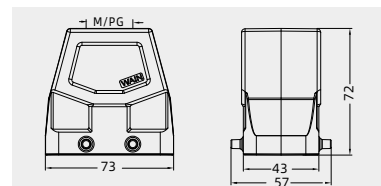

### Housings, cable to cable



Thread	Designation	Order No.
M20	W10B-MCCT-2L/SC-M20	112 110 741 1002
M25	W10B-MCCT-2L/SC-M25	112 110 741 1003
PG16	W10B-MCCT-2L/SC-PG16	112 110 741 1001

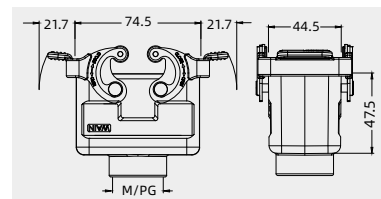

### Housings, cable to cable, high construction



Thread	Designation	Order No.
M25	W10B-MCCTH-2L/SC-M25	112 110 741 5003
M32	W10B-MCCTH-2L/SC-M32	112 110 741 5004
PG21	W10B-MCCTH-2L/SC-PG21	112 110 741 5011
PG29	W10B-MCCTH-2L/SC-PG29	112 110 741 5012

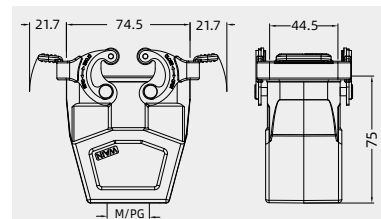

### Bulkhead mounted housings



Thread	Designation	Order No.
---	W10B-MBK-2L/SC	112 110 341 1001

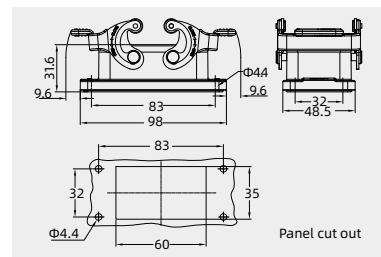

## 10B EMC Metal hoods/housings

Degree of protection: IP67

## Hoods, side entry



Thread	Designation	Order No.
M25	EMC.W10B-SE-4B-M20	111 210 530 1001
M32	EMC.W10B-SE-4B-M25	111 210 530 1002
PG29	EMC.W10B-SE-4B-PG16	111 210 530 1003

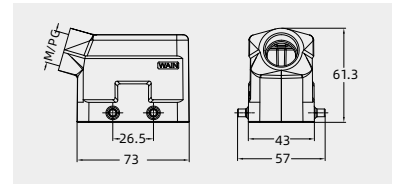

## Hoods, side entry, high construction



Thread	Designation	Order No.
M25	EMC.W10B-SEH-4B-M25	111 210 530 5001
M32	EMC.W10B-SEH-4B-M32	111 210 530 5002
PG21	EMC.W10B-SEH-4B-PG21	111 210 530 5003
PG29	EMC.W10B-SEH-4B-PG29	111 210 530 5004

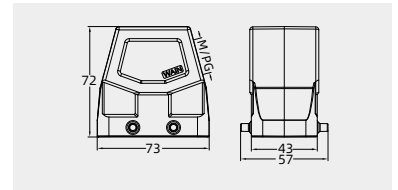

H

## Hoods, top entry



Thread	Designation	Order No.
M25	EMC.W10B-TE-4B-M20	111 210 430 1001
M32	EMC.W10B-TE-4B-M25	111 210 430 1002
PG29	EMC.W10B-TE-4B-PG16	111 210 430 1003

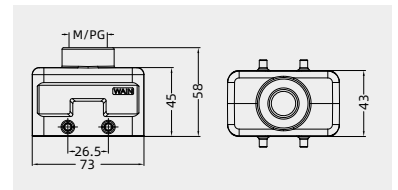

## Hoods, top entry, high construction



Thread	Designation	Order No.
M25	EMC.W10B-TEH-4B-M25	111 210 430 5001
M32	EMC.W10B-TEH-4B-M32	111 210 430 5002
PG21	EMC.W10B-TEH-4B-PG21	111 210 430 5003
PG29	EMC.W10B-TEH-4B-PG29	111 210 430 5004

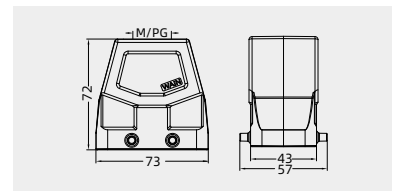

## Bulkhead mounted housings



Thread	Designation	Order No.
---	EMC1.W10B-BK-2L/SC	111 110 341 1001

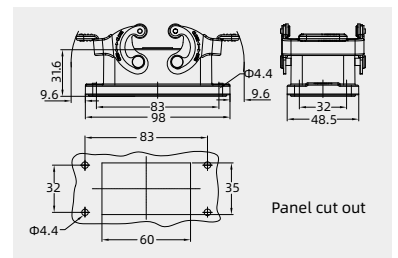

# 10B EMC Metal hoods/housings

Degree of protection: IP65



## Hoods, side entry



Thread	Designation	Order No.
M20	EMC.H10B-SF-2L/SC-M20	111 610 241 1502
2M20	EMC.H10B-SF-2L/SC-2M20	111 610 241 1503
PG16	EEMC.H10B-SF-2L/SC-PG16	111 610 241 1504
2PG16	EMC.H10B-SF-2L/SC-2PG16	111 610 241 1505

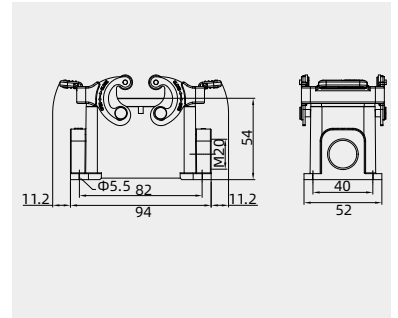

## Hoods, side entry, high construction



Thread	Designation	Order No.
M25	EMC.H10B-SFH-2L/SC-M25	111 610 241 5500
M32	EMC.H10B-SFH-2L/SC-2M25	111 610 241 5501
PG21	EMC.H10B-SFH-2L/SC-M32	111 610 241 5502
PG29	EMC.H10B-SFH-2L/SC-2M32	111 610 241 5503
PG21	EMC.H10B-SFH-2L/SC-PG21	111 610 241 5504
2PG21	EMC.H10B-SFH-2L/SC-2PG21	111 610 241 5505
PG29	EMC.H10B-SFH-2L/SC-PG29	111 610 241 5506
2PG29	EMC.H10B-SFH-2L/SC-2PG29	111 610 241 5507

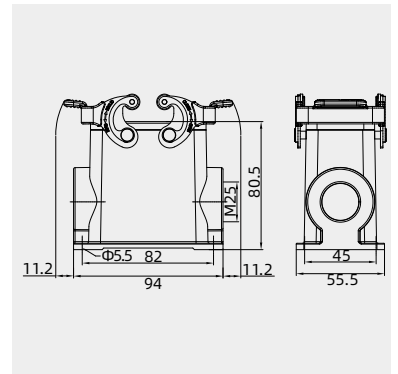

## 10B Pressure tight hoods/housings

Degree of protection: IP68/IP69K

W version

## Hoods, side entry, high construction



Thread	Designation	Order No.
M20	HP10B-SEH-2S-M20	115 010 520 5002
M25	HP10B-SEH-2S-M25	115 010 520 5103
M32	HP10B-SEH-2S-M32	115 010 520 5104
PG16	HP10B-SEH-2S-PG16	115 010 520 5110
PG21	HP10B-SEH-2S-PG21	115 010 520 5111

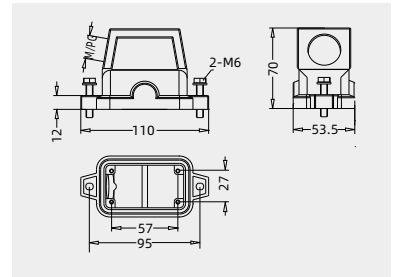

## Hoods, top entry, high construction



Thread	Designation	Order No.
M20	HP10B-TEH-2S-M20	115 010 420 5002
M25	HP10B-TEH-2S-M25	115 010 420 5103
M32	HP10B-TEH-2S-M32	115 010 420 5104
PG16	HP10B-TEH-2S-PG16	115 010 420 5110
PG21	HP10B-TEH-2S-PG21	115 010 420 5111
PG29	HP10B-TEH-2S-PG29	115 010 420 5012

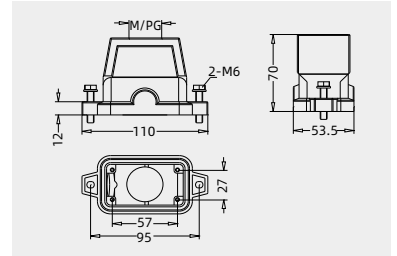

## Surface mounted housings, high construction



Thread	Designation	Order No.
M20	HP10B-SFH-2H-M20	115 010 220 5002
M25	HP10B-SFH-2H-M25	115 010 220 5003
M32	HP10B-SFH-2H-M32	115 010 220 5004
PG16	HP10B-SFH-2H-PG16	115 010 220 5010
PG21	HP10B-SFH-2H-PG21	115 010 220 5011

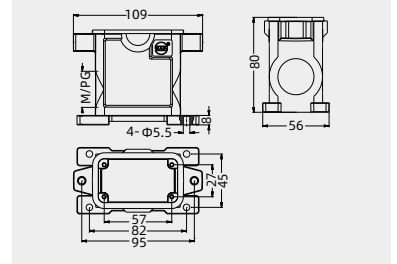

## Bulkhead mounted housings



Thread	Designation	Order No.
---	HP10B-BK-2H	115 010 320 1001

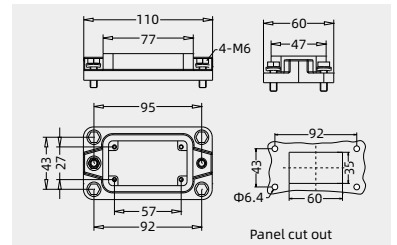

## Protection covers, plastic



Thread	Designation	Order No.
---	HP10B-CV-2S/2	115 010 020 8002

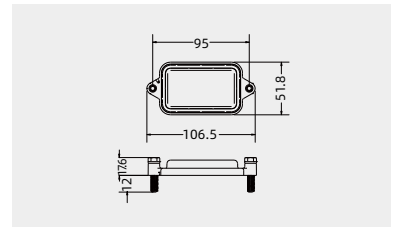



10B Pressure tight hoods/housings

Degree of protection: IP68/IP69K

H version

Hoods, side entry, high construction



Thread	Designation	Order No.
	Screw locking	
M20	HP10B/H-SEH-2S-M20	113 610 520 5002
M25	HP10B/H-SEH-2S-M25	113 610 520 5003
M32	HP10B/H-SEH-2S-M32	113 610 520 5004
PG16	HP10B/H-SEH-2S-PG16	113 610 520 5010
PG21	HP10B/H-SEH-2S-PG21	113 610 520 5011
	Toggle locking	
M20	HP10B/H-SEH-2T-M20	113 610 540 5002
M25	HP10B/H-SEH-2T-M25	113 610 540 5003
M32	HP10B/H-SEH-2T-M32	113 610 540 5004
PG16	HP10B/H-SEH-2T-PG16	113 610 540 5010
PG21	HP10B/H-SEH-2T-PG21	113 610 540 5011

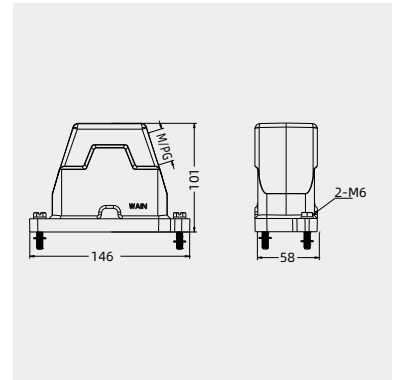

Hoods, top entry, high construction



Thread	Designation	Order No.
	Screw locking	
M20	HP10B/H-TEH-2S-M20	113 610 420 5002
M25	HP10B/H-TEH-2S-M25	113 610 420 5003
M32	HP10B/H-TEH-2S-M32	113 610 420 5004
PG16	HP10B/H-TEH-2S-PG16	113 610 420 5010
PG21	HP10B/H-TEH-2S-PG21	113 610 420 5011
PG29	HP10B/H-TEH-2S-PG29	113 610 420 5012
	Toggle locking	
M20	HP10B/H-TEH-2T-M20	113 610 440 5002
M25	HP10B/H-TEH-2T-M25	113 610 440 5003
M32	HP10B/H-TEH-2T-M32	113 610 440 5004
PG16	HP10B/H-TEH-2T-PG16	113 610 440 5010
PG21	HP10B/H-TEH-2T-PG21	113 610 440 5011
PG29	HP10B/H-TEH-2T-PG29	113 610 440 5012

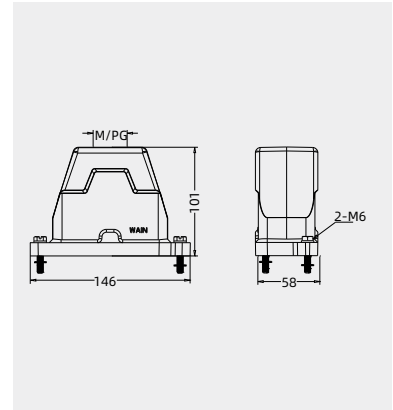

Surface mounted housings, high construction



Thread	Designation	Order No.
	Screw locking	
M20	HP10B/H-SFH-2H-M20	113 610 220 5002
M25	HP10B/H-SFH-2H-M25	113 610 220 5003
M32	HP10B/H-SFH-2H-M32	113 610 220 5004
PG16	HP10B/H-SFH-2H-PG16	113 610 220 5010
PG21	HP10B/H-SFH-2H-PG21	113 610 220 5011
	Toggle locking	
M20	HP10B/H-SFH-2T-M20	113 610 240 5002
M25	HP10B/H-SFH-2T-M25	113 610 240 5003
M32	HP10B/H-SFH-2T-M32	113 610 240 5004
PG16	HP10B/H-SFH-2T-PG16	113 610 240 5010
PG21	HP10B/H-SFH-2T-PG21	113 610 240 5011

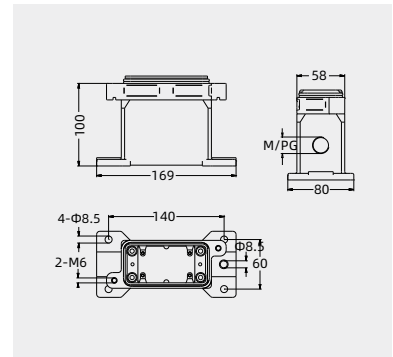

Bulkhead mounted housings



Thread	Designation	Order No.
	Screw locking	
---	HP10B/H-BK-2H	113 610 320 1001
	Toggle locking	
---	HP10B/H-BK-2T	113 610 340 1001
	with metal cover	
	Screw locking	
---	HP10B/H-BK-2H-MCV	113 610 360 1001
	Toggle locking	
---	HP10B/H-BK-2T-MCV	113 610 370 1001

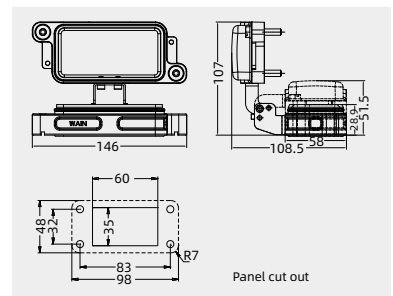

10B Pressure tight hoods/housings

Degree of protection: IP68/IP69K

H version

Protection covers,for housings



Connect way	Designation	Order No.
	Screw locking	113 610 020 8101
	HP10B/H-MCV-2S	
	Toggle locking	113 610 040 8103
	HP10B/H-MCV-2T	

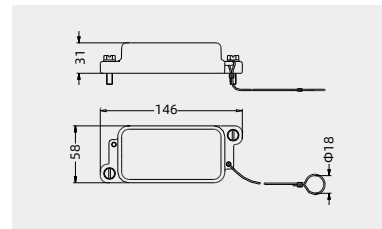

Protection covers,for hoods



Connect way	Designation	Order No.
	Screw locking	113 610 020 8111
	HP10B/H-MCV-2H/1	
	Toggle locking	113 610 040 8101
	HP10B/H-MCV-2T/1	

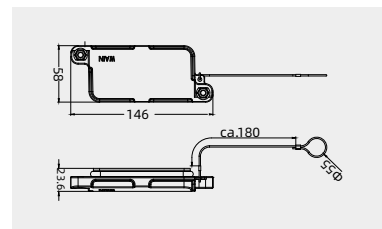

Protection covers, for housings(IP5X)



Connect way	Designation	Order No.
---	HP10B/H-CV/C	113 010 900 8001

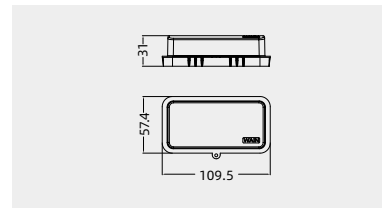

Degree of protection: IP68/IP69K

The following hoods/housings comply with the standards for rail transport industry in China.

H version

Hoods, side entry, high construction



Thread	Designation	Order No.
M20	HP10B/H-SEH-4S-M20	113 610 530 5002
M25	HP10B/H-SEH-4S-M25	113 610 530 5003
M32	HP10B/H-SEH-4S-M32	113 610 530 5004
M40	HP10B/H-SEH-4S-M40	113 610 530 5005
PG16	HP10B/H-SEH-4S-PG16	113 610 530 5010
PG21	HP10B/H-SEH-4S-PG21	113 610 530 5011

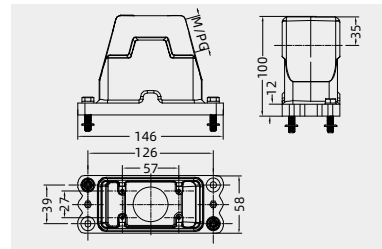

Hoods, top entry, high construction



Thread	Designation	Order No.
M20	HP10B/H-TEH-4S-M20	113 610 430 5002
M25	HP10B/H-TEH-4S-M25	113 610 430 5003
M32	HP10B/H-TEH-4S-M32	113 610 430 5004
M40	HP10B/H-TEH-4S-M40	113 610 430 5005
PG16	HP10B/H-TEH-4S-PG16	113 610 430 5010
PG21	HP10B/H-TEH-4S-PG21	113 610 430 5011
PG29	HP10B/H-TEH-4S-PG29	113 610 430 5012

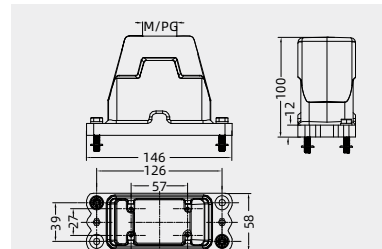

Bulkhead mounted housings



Thread	Designation	Order No.
---	HP10B/H-BK-4H	113 610 330 1001

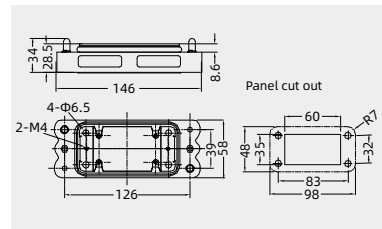

10B Pressure tight hoods/housings

Degree of protection: IP68/IP69K

Hoods, side entry, high construction



Thread	Designation	Order No.
M25	HC10B-SEH-2S-M25	114 010 520 5003
M32	HC10B-SEH-2S-M32	114 010 520 5004
PG16	HC10B-SEH-2S-PG16	114 010 520 5010
PG21	HC10B-SEH-2S-PG21	114 010 520 5011

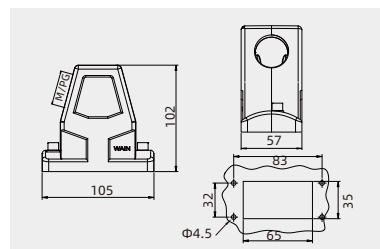

Hoods, side entry, high construction



Thread	Designation	Order No.
M25	HC10B-TEH-2S-M25	114 010 420 5003
M32	HC10B-TEH-2S-M32	114 010 420 5004
PG16	HC10B-TEH-2S-PG16	114 010 420 5010
PG21	HC10B-TEH-2S-PG21	114 010 420 5011

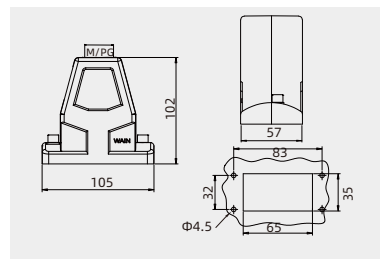

Mounting flange



Applications	Designation	Order No.
for integral type hoods	APT-C	114 000 000 1001

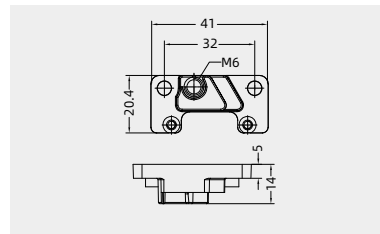

Protection covers, plastic



Thread	Designation	Order No.
---	HC10B-CV-2S/2	111 010 020 8001

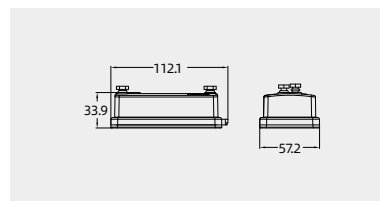

## 10B Pressure tight hoods/housings

Degree of protection: IP68/IP69K

EMC Pressure tight hoods/housings

## Hoods, top entry, high construction



Thread	Designation	Order No.
M20	EMC.W10B-TEH-4S-M20	111 210 430 5005
M25	EMC.W10B-TEH-4S-M25	111 110 430 5002
M32	EMC.W10B-TEH-4S-M32	111 110 430 5003
PG21	EMC.W10B-TEH-4S-PG21	111 210 430 5006
PG29	EMC.W10B-TEH-4S-PG29	111 210 430 5007

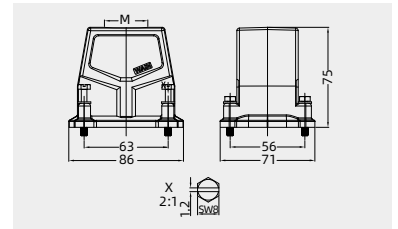

## Hoods, side entry, high construction



Thread	Designation	Order No.
M20	EMC.W10B-SEH-4S-M20	112 110 530 5003
M25	EMC.W10B-SEH-4S-M25	112 110 530 5004
M32	EMC.W10B-SEH-4S-M32	112 110 530 5002
PG21	EMC.W10B-SEH-4S-PG21	112 110 530 5005
PG29	EMC.W10B-SEH-4S-PG29	112 110 530 5006

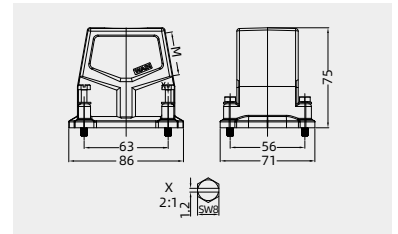

## Bulkhead mounted housings



Thread	Designation	Order No.
---	EMC.W10B-BK-4H	111 210 330 1001

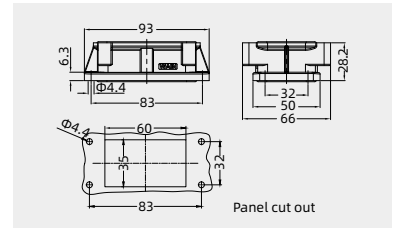

HV10B Metal hoods/housings  
- for high voltage inserts(HVE Series)

Degree of protection: IP65

Hoods, side entry



Thread	Designation	Order No.
M20	HV10B-SE-2B-M20	124 010 515 1002
PG16	HV10B-SE-2B-PG16	124 010 515 1010

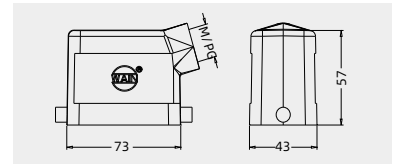

Hoods, side entry, high construction



Thread	Designation	Order No.
M25	WV10B-SEH-2B-M25	124 110 510 5001
M32	WV10B-SEH-2B-M32	124 110 510 5002
PG21	WV10B-SEH-2B-PG21	124 110 510 5003
PG29	WV10B-SEH-2B-PG29	124 110 510 5004
	with sleeve	
M25	WV10B-SEH-2B-M25 WS	124 110 515 5103
M32	WV10B-SEH-2B-M32 WS	124 110 515 5104
PG21	WV10B-SEH-2B-PG21 WS	124 110 515 5111
PG29	WV10B-SEH-2B-PG29 WS	124 110 515 5112

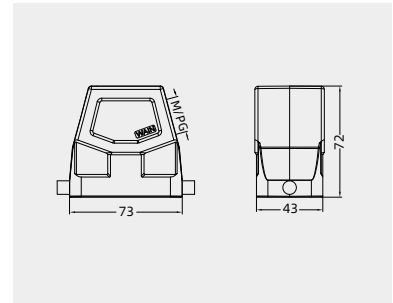

Hoods, top entry



Thread	Designation	Order No.
M20	HV10B-TE-2B-M20	124 010 415 1002
PG16	HV10B-TE-2B-PG16	124 010 415 1010

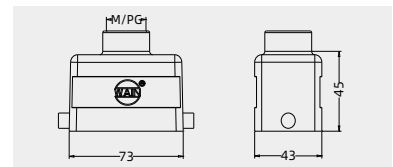

Hoods, top entry, high construction



Thread	Designation	Order No.
M25	WV10B-TEH-2B-M25	124 110 410 5001
M32	WV10B-TEH-2B-M32	124 110 410 5002
PG21	WV10B-TEH-2B-PG21	124 110 410 5003
PG29	WV10B-TEH-2B-PG29	124 110 410 5004
	with sleeve	
M25	WV10B-TEH-2B-M25 WS	124 110 415 5103
M32	WV10B-TEH-2B-M32 WS	124 110 415 5104
PG21	WV10B-TEH-2B-PG21 WS	124 110 415 5111
PG29	WV10B-TEH-2B-PG29 WS	124 110 415 5112

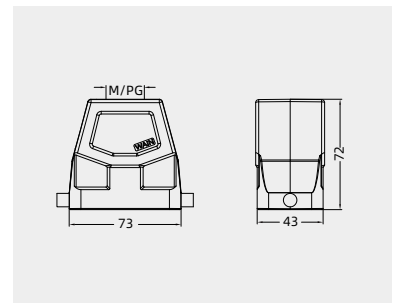

Housings, cable to cable



Thread	Designation	Order No.
M20	HV10B-CCT-1L/SC-M20	124 010 721 1002
PG16	HV10B-CCT-1L/SC-PG16	124 010 721 1010

Please refer to page 15-02 for choosing proper model of lock.

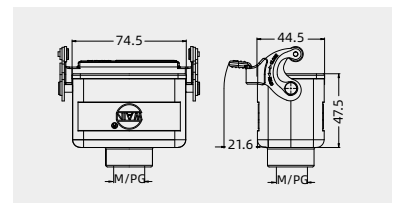

Housings, cable to cable, high construction



Thread	Designation	Order No.
M25	WV10B-CCTH-1L/SC-M25	124 110 721 5001
M32	WV10B-CCTH-1L/SC-M32	124 110 721 5002
PG21	WV10B-CCTH-1L/SC-PG21	124 110 721 5003
PG29	WV10B-CCTH-1L/SC-PG29	124 110 721 5004
	with sleeve	
M25	WV10B-CCTH-1L/SC-M25 WS	124 110 721 5103
M32	WV10B-CCTH-1L/SC-M32 WS	124 110 721 5104
PG21	WV10B-CCTH-1L/SC-PG21 WS	124 110 721 5111
PG29	WV10B-CCTH-1L/SC-PG29 WS	124 110 721 5112

Please refer to page 15-02 for choosing proper model of lock.

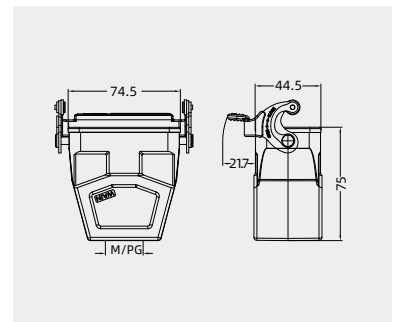

# HV10B Metal hoods/housings - for high voltage inserts(HVE Series)

Degree of protection: IP65

## Bulkhead mounted housings



Thread	Designation	Order No.
---	HV10B-BK-1L/SC	124 010 321 1001
with plastic cover		
---	HV10B-BK-1L/SC-CV	124 010 361 1001
with metal cover		
---	HV10B-BK-1L/SC-MCV	124 010 361 1101

Please refer to page 15-02 for choosing proper model of lock.

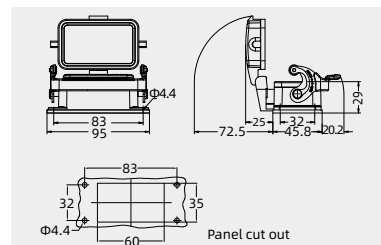

## Surface mounted housings

### Structure 1



Thread	Designation	Order No.
M20	HV10B-SF-1L/SC-M20	124 010 221 1002
2M20	HV10B-SF-1L/SC-2M20	124 010 221 1022
M25	HV10B-SF-1L/SC-M25 <sup>1)</sup>	124 010 221 1003
2M25	HV10B-SF-1L/SC-2M25 <sup>1)</sup>	124 010 221 1023
PG16	HV10B-SF-1L/SC-PG16	124 010 221 1010
2PG16	HV10B-SF-1L/SC-2PG16	124 010 221 1030
with plastic cover		
M20	HV10B-SF-1L/SC-CV-M20	124 010 261 1002
2M20	HV10B-SF-1L/SC-CV-2M20	124 010 261 1022
M25	HV10B-SF-1L/SC-CV-M25 <sup>1)</sup>	124 010 261 1003
2M25	HV10B-SF-1L/SC-CV-2M25 <sup>1)</sup>	124 010 261 1023
PG16	HV10B-SF-1L/SC-CV-PG16	124 010 261 1010
2PG16	HV10B-SF-1L/SC-CV-2PG16	124 010 261 1030
with metal cover		
M20	HV10B-SF-1L/SC-MCV-M20	124 010 261 1102
2M20	HV10B-SF-1L/SC-MCV-2M20	124 010 261 1122
M25	HV10B-SF-1L/SC-MCV-M25 <sup>1)</sup>	124 010 261 1103
2M25	HV10B-SF-1L/SC-MCV-2M25 <sup>1)</sup>	124 010 261 1123
PG16	HV10B-SF-1L/SC-MCV-PG16	124 010 261 1110
2PG16	HV10B-SF-1L/SC-MCV-2PG16	124 010 261 1130

Please refer to page 15-02 for choosing proper model of lock.

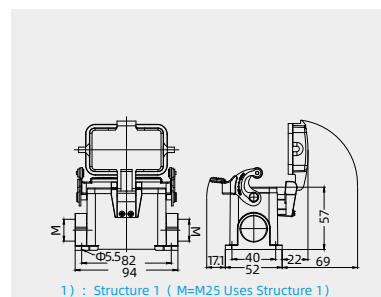

1) : Structure 1 ( M=M25 Uses Structure 1 )

### Structure 2

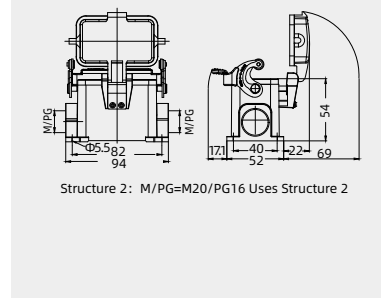

Structure 2: M/PG=M20/PG16 Uses Structure 2

## Surface mounted housings, high construction



Thread	Designation	Order No.
M25	HV10B-SFH-1L/SC-M25	124 010 221 5003
2M25	HV10B-SFH-1L/SC-2M25	124 010 221 5023
M32	HV10B-SFH-1L/SC-M32	124 010 221 5004
2M32	HV10B-SFH-1L/SC-2M32	124 010 221 5024
PG21	HV10B-SFH-1L/SC-PG21	124 010 221 5011
2PG21	HV10B-SFH-1L/SC-2PG21	124 010 221 5031
PG29	HV10B-SFH-1L/SC-PG29	124 010 221 5012
2PG29	HV10B-SFH-1L/SC-2PG29	124 010 221 5032
with plastic cover		
M25	HV10B-SFH-1L/SC-CV-M25	124 010 261 5003
2M25	HV10B-SFH-1L/SC-CV-2M25	124 010 261 5023
M32	HV10B-SFH-1L/SC-CV-M32	124 010 261 5004
2M32	HV10B-SFH-1L/SC-CV-2M32	124 010 261 5024
PG21	HV10B-SFH-1L/SC-CV-PG21	124 010 261 5011
2PG21	HV10B-SFH-1L/SC-CV-2PG21	124 010 261 5031
PG29	HV10B-SFH-1L/SC-CV-PG29	124 010 261 5012
2PG29	HV10B-SFH-1L/SC-CV-2PG29	124 010 261 5032
with metal cover		
M25	HV10B-SFH-1L/SC-MCV-M25	124 010 261 5103
2M25	HV10B-SFH-1L/SC-MCV-2M25	124 010 261 5123
M32	HV10B-SFH-1L/SC-MCV-M32	124 010 261 5104
2M32	HV10B-SFH-1L/SC-MCV-2M32	124 010 261 5124
PG21	HV10B-SFH-1L/SC-MCV-PG21	124 010 261 5111
2PG21	HV10B-SFH-1L/SC-MCV-2PG21	124 010 261 5131
PG29	HV10B-SFH-1L/SC-MCV-PG29	124 010 261 5112
2PG29	HV10B-SFH-1L/SC-MCV-2PG29	124 010 261 5132

Please refer to page 15-02 for choosing proper model of lock.

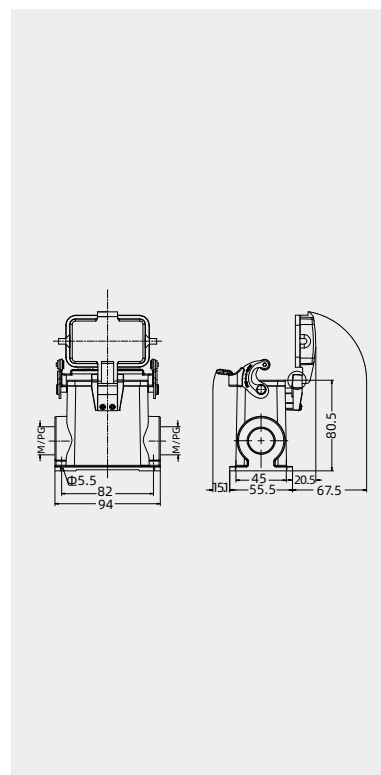

# HV10B Metal hoods/housings - for high voltage inserts(HVE Series)

Degree of protection: IP65

## Hoods, side entry



Thread	Designation	Order No.
M20	HV10B-SE-4B-M20	124 010 530 1002
PG16	HV10B-SE-4B-PG16	124 010 530 1010

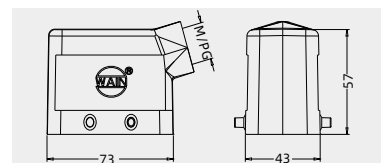

## Hoods, side entry, high construction



Thread	Designation	Order No.
M25	WV10B-SEH-4B-M25	124 110 530 5001
M32	WV10B-SEH-4B-M32	124 110 530 5002
PG21	WV10B-SEH-4B-PG21	124 110 530 5003
PG29	WV10B-SEH-4B-PG29	124 110 530 5004
	with sleeve	
M25	WV10B-SEH-4B-M25 <i>WS</i>	124 110 530 5103
M32	WV10B-SEH-4B-M32 <i>WS</i>	124 110 530 5104
PG21	WV10B-SEH-4B-PG21 <i>WS</i>	124 110 530 5111
PG29	WV10B-SEH-4B-PG29 <i>WS</i>	124 110 530 5112

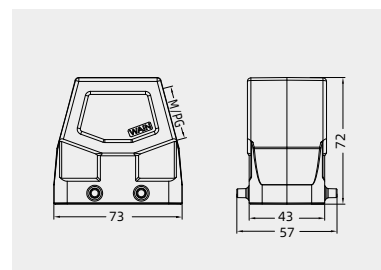

## Hoods, top entry



Thread	Designation	Order No.
M20	HV10B-TE-4B-M20	124 010 430 1002
PG16	HV10B-TE-4B-PG16	124 010 430 1010

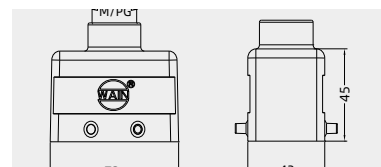

## Hoods, top entry, high construction



Thread	Designation	Order No.
M25	WV10B-TEH-4B-M25	124 110 430 5001
M32	WV10B-TEH-4B-M32	124 110 430 5002
PG21	WV10B-TEH-4B-PG21	124 110 430 5003
PG29	WV10B-TEH-4B-PG29	124 110 430 5004
	with sleeve	
M25	WV10B-TEH-4B-M25 <i>WS</i>	124 110 430 5103
M32	WV10B-TEH-4B-M32 <i>WS</i>	124 110 430 5104
PG21	WV10B-TEH-4B-PG21 <i>WS</i>	124 110 430 5111
PG29	WV10B-TEH-4B-PG29 <i>WS</i>	124 110 430 5112

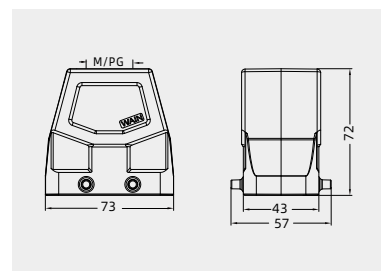

## Bulkhead mounted housings



Thread	Designation	Order No.
---	HV10B-BK-2L/SC	124 010 341 1001

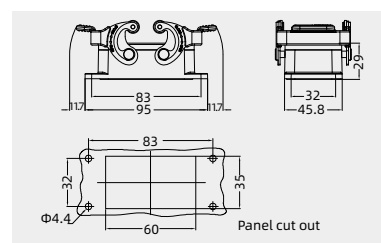

Please refer to page 15-02 for choosing proper model of lock.

## Surface mounted housings

### Structure 1



Thread	Designation	Order No.
M20	HV10B-SF-2L/SC-M20	124 010 241 1002
2M20	HV10B-SF-2L/SC-2M20	124 010 241 1022
M25	HV10B-SF-2L/SC-M25 <sup>1)</sup>	124 010 241 1003
2M25	HV10B-SF-2L/SC-2M25 <sup>1)</sup>	124 010 241 1023
2PG16	HV10B-SF-2L/SC-PG16	124 010 241 1010
2PG16	HV10B-SF-2L/SC-2PG16	124 010 241 1030

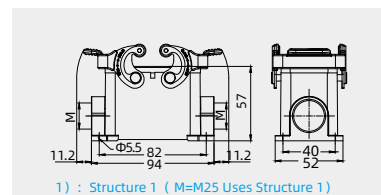

1) : Structure 1 ( M=M25 Uses Structure 1 )

### Structure 2

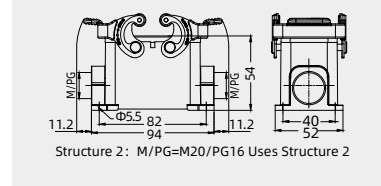

Structure 2: M/PG=M20/PG16 Uses Structure 2

HV10B Metal hoods/housings  
- for high voltage inserts(HVE Series)

Degree of protection: IP65

Surface mounted housings, high construction



Thread	Designation	Order No.
M25	HV10B-SFH-2L/SC-M25	124 010 241 5003
2M25	HV10B-SFH-2L/SC-2M25	124 010 241 5023
M32	HV10B-SFH-2L/SC-M32	124 010 241 5004
2M32	HV10B-SFH-2L/SC-2M32	124 010 241 5024
PG21	HV10B-SFH-2L/SC-PG21	124 010 241 5011
2PG21	HV10B-SFH-2L/SC-2PG21	124 010 241 5031
PG29	HV10B-SFH-2L/SC-PG29	124 010 241 5012
2PG29	HV10B-SFH-2L/SC-2PG29	124 010 241 5032

Please refer to page 15-02 for choosing proper model of lock.

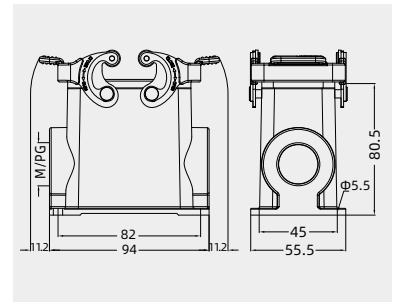

Housings, cable to cable



Thread	Designation	Order No.
M20	HV10B-CCT-2L/SC-M20	124 010 741 1002
PG16	HV10B-CCT-2L/SC-PG16	124 010 741 1010

Please refer to page 15-02 for choosing proper model of lock.

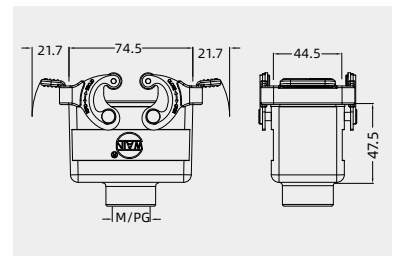

Housings, cable to cable, high construction



Thread	Designation	Order No.
M25	WV10B-CCTH-2L/SC-M25	124 110 741 5001
M32	WV10B-CCTH-2L/SC-M32	124 110 741 5002
PG21	WV10B-CCTH-2L/SC-PG21	124 110 741 5003
PG29	WV10B-CCTH-2L/SC-PG29	124 110 741 5004
	with sleeve	
M25	WV10B-CCTH-2L/SC-M25 WS	124 110 741 5103
M32	WV10B-CCTH-2L/SC-M32 WS	124 110 741 5104
PG21	WV10B-CCTH-2L/SC-PG21 WS	124 110 741 5111
PG29	WV10B-CCTH-2L/SC-PG29 WS	124 110 741 5112

Please refer to page 15-02 for choosing proper model of lock.

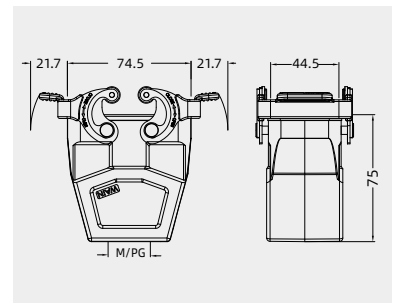

Protection covers, plastic



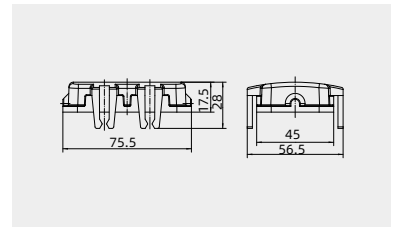

Connect way	Applications	Designation	Order No.
---	for hoods	H10B-CV-4C	111 010 090 8009



Protection covers, plastic



Connect way	Applications	Designation	Order No.
	for Housings, cable to cable	H10B-CV-4B/1	111 010 030 8001
	for Housings, bulkhead mounting / surface mounting	H10B-CV-4B/2	111 010 030 8002

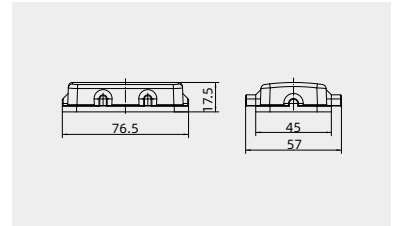



HV10B Metal hoods/housings  
- for high voltage inserts(HVE Series)

Degree of protection: IP65

Hoods, side entry



Thread	Designation	Order No.
M20	HV10B-SE-2L/SC-M20	124 010 541 1002
PG16	HV10B-SE-2L/SC-PG16	124 010 541 1010

Please refer to page 15-02 for choosing proper model of lock.

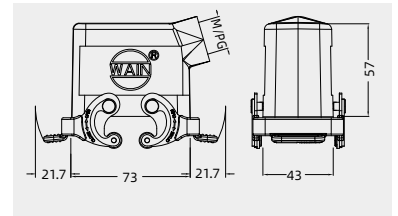

Hoods, side entry, high construction



Thread	Designation	Order No.
M25	WV10B-SEH-2L/SC-M25	124 110 541 5001
M32	WV10B-SEH-2L/SC-M32	124 110 541 5002
PG21	WV10B-SEH-2L/SC-PG21	124 110 541 5003
PG29	WV10B-SEH-2L/SC-PG29	124 110 541 5004
M25	WV10B-SEH-2L/SC-M25 WS	124 110 541 5103
M32	WV10B-SEH-2L/SC-M32 WS	124 110 541 5104
PG21	WV10B-SEH-2L/SC-PG21 WS	124 110 541 5111
PG29	WV10B-SEH-2L/SC-PG29 WS	124 110 541 5012

Please refer to page 15-02 for choosing proper model of lock.

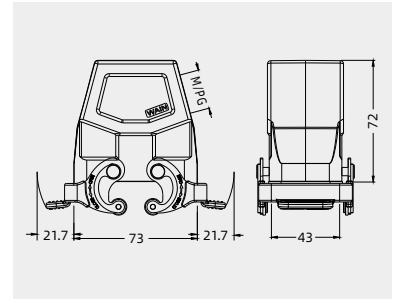

Hoods, top entry



Thread	Designation	Order No.
M20	HV10B-TE-2L/SC-M20	124 010 441 1002
PG16	HV10B-TE-2L/SC-PG16	124 010 441 1010

Please refer to page 15-02 for choosing proper model of lock.

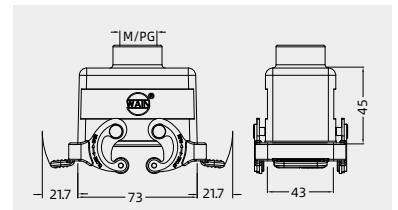

Hoods, top entry, high construction



Thread	Designation	Order No.
M25	WV10B-TEH-2L/SC-M25	124 110 441 5001
M32	WV10B-TEH-2L/SC-M32	124 110 441 5002
PG21	WV10B-TEH-2L/SC-PG21	124 110 441 5003
PG29	WV10B-TEH-2L/SC-PG29	124 110 441 5004
M25	WV10B-TEH-2L/SC-M25 WS	124 110 441 5103
M32	WV10B-TEH-2L/SC-M32 WS	124 110 441 5104
PG21	WV10B-TEH-2L/SC-PG21 WS	124 110 441 5111
PG29	WV10B-TEH-2L/SC-PG29 WS	124 110 441 5112

Please refer to page 15-02 for choosing proper model of lock.

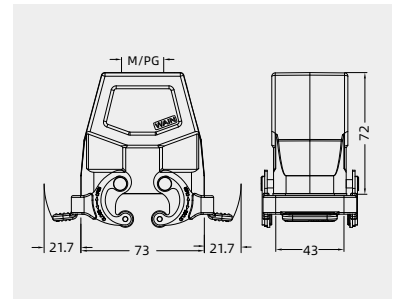

Bulkhead mounted housings



Thread	Designation	Order No.
---	HV10B-BK-4B	124 010 330 1001
---	with plastic cover HV10B-BK-4B-CV	124 010 370 1001
---	with metal cover HV10B-BK-4B-MCV	124 010 370 1101

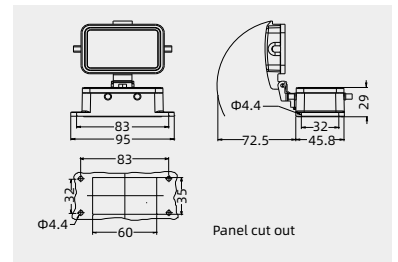

10B Metal hoods/housings  
- for high voltage inserts(HVE Series)

Degree of protection: IP65

Surface mounted housings

Structure 1



Thread	Designation	Order No.
M20	HV10B-SF-4B-M20	124 010 230 1002
2M20	HV10B-SF-4B-2M20	124 010 230 1022
M25	HV10B-SF-4B-M25 <sup>1)</sup>	124 010 230 1003
2M25	HV10B-SF-4B-2M25 <sup>1)</sup>	124 010 230 1023
PG16	HV10B-SF-4B-PG16	124 010 230 1010
2PG16	HV10B-SF-4B-2PG16	124 010 230 1030

with plastic cover

M20	HV10B-SF-4B-CV-M20	124 010 270 1002
2M20	HV10B-SF-4B-CV-2M20	124 010 270 1022
M25	HV10B-SF-4B-CV-M25 <sup>1)</sup>	124 010 270 1003
2M25	HV10B-SF-4B-CV-2M25 <sup>1)</sup>	124 010 270 1023
PG16	HV10B-SF-4B-CV-PG16	124 010 270 1010
2PG16	HV10B-SF-4B-CV-2PG16	124 010 270 1030

with metal cover

M20	HV10B-SF-4B-MCV-M20	124 010 270 1102
2M20	HV10B-SF-4B-MCV-2M20	124 010 270 1122
M25	HV10B-SF-4B-MCV-M25 <sup>1)</sup>	124 010 270 1103
2M25	HV10B-SF-4B-MCV-2M25 <sup>1)</sup>	124 010 270 1123
PG16	HV10B-SF-4B-MCV-PG16	124 010 270 1110
2PG16	HV10B-SF-4B-MCV-2PG16	124 010 270 1130

Structure 2

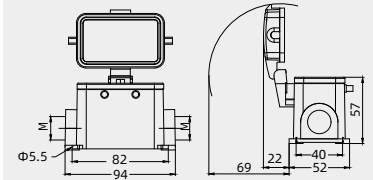

1) : Structure 1 ( M=M25 Uses Structure 1)

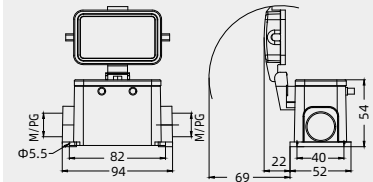

Structure 2 : M/PG=M20/PG16 Uses Structure 2

Surface mounted housings, high construction



Thread	Designation	Order No.
M25	HV10B-SFH-4B-M25	124 010 230 5003
2M25	HV10B-SFH-4B-2M25	124 010 230 5023
M32	HV10B-SFH-4B-M32	124 010 230 5004
2M32	HV10B-SFH-4B-2M32	124 010 230 5024
PG21	HV10B-SFH-4B-PG21	124 010 230 5011
2PG21	HV10B-SFH-4B-2PG21	124 010 230 5031
PG29	HV10B-SFH-4B-PG29	124 010 230 5012
2PG29	HV10B-SFH-4B-2PG29	124 010 230 5032

with plastic cover

M25	HV10B-SFH-4B-CV-M25	124 010 270 5003
2M25	HV10B-SFH-4B-CV-2M25	124 010 270 5023
M32	HV10B-SFH-4B-CV-M32	124 010 270 5004
2M32	HV10B-SFH-4B-CV-2M32	124 010 270 5024
PG21	HV10B-SFH-4B-CV-PG21	124 010 270 5011
2PG21	HV10B-SFH-4B-CV-2PG21	124 010 270 5031
PG29	HV10B-SFH-4B-CV-PG29	124 010 270 5012
2PG29	HV10B-SFH-4B-CV-2PG29	124 010 270 5032

with metal cover

M25	HV10B-SFH-4B-MCV-M25	124 010 270 5103
2M25	HV10B-SFH-4B-MCV-2M25	124 010 270 5123
M32	HV10B-SFH-4B-MCV-M32	124 010 270 5104
2M32	HV10B-SFH-4B-MCV-2M32	124 010 270 5124
PG21	HV10B-SFH-4B-MCV-PG21	124 010 270 5111
2PG21	HV10B-SFH-4B-MCV-2PG21	124 010 270 5131
PG29	HV10B-SFH-4B-MCV-PG29	124 010 270 5112
2PG29	HV10B-SFH-4B-MCV-2PG29	124 010 270 5132

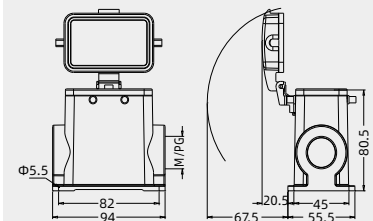

10B Metal hoods/housings  
- for high voltage inserts(HVE Series)

Degree of protection: IP65

Protection covers, metal



Connect way	Applications	Designation	Order No.
	for hoods	H10B-MCV-4B/1S	111 010 030 8103
	for housings, without sealing	H10B-MCV-4B/2	111 010 030 8102

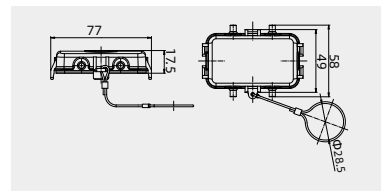

Protection covers, metal



Connect way	Applications	Designation	Order No.
	for hoods	H10B-MCV-2L/SC.1S	111 010 041 8101
	for housings,	H10B-MCV-2L/SC.2	111 010 041 8102

Please refer to page 15-02 for choosing proper model of lock.

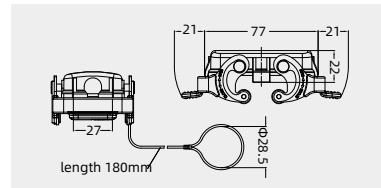

# 10B Metal hoods/housings - for high voltage inserts(HVE Series)

Degree of protection: IP67

## Hoods, side entry



Thread	Designation	Order No.
M20	WV10B-SE-2B-M20	124 110 510 1001
PG16	WV10B-SE-2B-PG16	124 110 510 1002

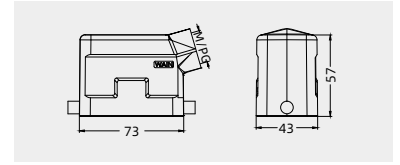

## Hoods, side entry, high construction



Thread	Designation	Order No.
M25	WV10B-SEH-2B-M25	124 110 510 5001
M32	WV10B-SEH-2B-M32	124 110 510 5002
PG21	WV10B-SEH-2B-PG21	124 110 510 5003
PG29	WV10B-SEH-2B-PG29	124 110 510 5004
	with sleeve	
M25	WV10B-SEH-2B-M25 <a href="#">WS</a>	124 110 515 5103
M32	WV10B-SEH-2B-M32 <a href="#">WS</a>	124 110 515 5104
PG21	WV10B-SEH-2B-PG21 <a href="#">WS</a>	124 110 515 5111
PG29	WV10B-SEH-2B-PG29 <a href="#">WS</a>	124 110 515 5112

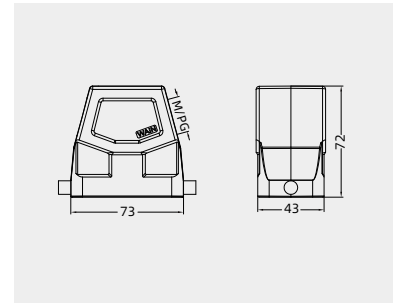

## Hoods, top entry



Thread	Designation	Order No.
M20	WV10B-TE-2B-M20	124 110 410 1001
PG16	WV10B-TE-2B-PG16	124 110 410 1002

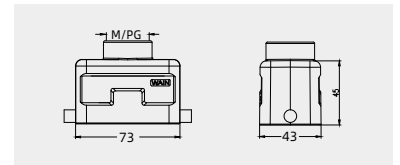

## Hoods, top entry, high construction



Thread	Designation	Order No.
M25	WV10B-TEH-2B-M25	124 110 410 5001
M32	WV10B-TEH-2B-M32	124 110 410 5002
PG21	WV10B-TEH-2B-PG21	124 110 410 5003
PG29	WV10B-TEH-2B-PG29	124 110 410 5004
	with sleeve	
M25	WV10B-TEH-2B-M25 <a href="#">WS</a>	124 110 415 5103
M32	WV10B-TEH-2B-M32 <a href="#">WS</a>	124 110 415 5104
PG21	WV10B-TEH-2B-PG21 <a href="#">WS</a>	124 110 415 5111
PG29	WV10B-TEH-2B-PG29 <a href="#">WS</a>	124 110 415 5112

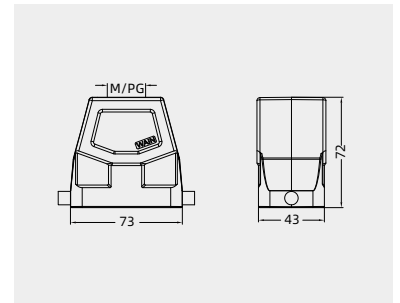

10B Metal hoods/housings  
- for high voltage inserts(HVE Series)

Degree of protection: IP67

Housings, cable to cable



Thread	Designation	Order No.
M20	WV10B-CCT-1L/SC-M20	124 110 721 1001
PG16	WV10B-CCT-1L/SC-PG16	124 110 721 1002

Please refer to page 15-02 for choosing proper model of lock.

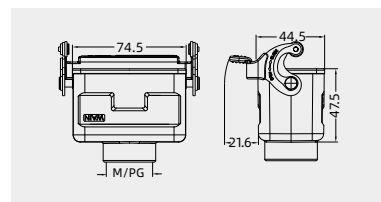

Housings, cable to cable, high construction



Thread	Designation	Order No.
M25	WV10B-CCTH-1L/SC-M25	124 110 721 5001
M32	WV10B-CCTH-1L/SC-M32	124 110 721 5002
PG21	WV10B-CCTH-1L/SC-PG21	124 110 721 5003
PG29	WV10B-CCTH-1L/SC-PG29	124 110 721 5004
	with sleeve	
M25	WV10B-CCTH-1L/SC-M25 WS	124 110 721 5103
M32	WV10B-CCTH-1L/SC-M32 WS	124 110 721 5104
PG21	WV10B-CCTH-1L/SC-PG21 WS	124 110 721 5111
PG29	WV10B-CCTH-1L/SC-PG29 WS	124 110 721 5112

Please refer to page 15-02 for choosing proper model of lock.

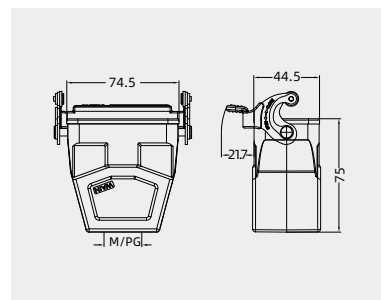

Bulkhead mounted housings



Thread	Designation	Order No.
---	WV10B-BK-1L/SC	124 110 361 1101
	with plastic cover	
---	WV10B-BK-1L/SC-CV	111 110 321 8003
	with metal cover	
---	WV10B-BK-1L/SC-MCV	111 110 321 8004

Please refer to page 15-02 for choosing proper model of lock.

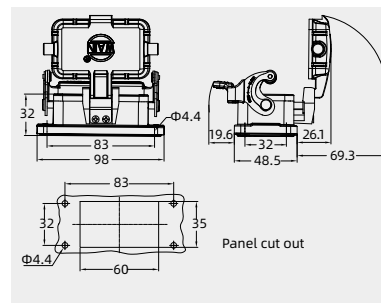

## 10B Metal hoods/housings - for high voltage inserts(HVE Series)

Degree of protection: IP67

### Hoods, side entry



Thread	Designation	Order No.
M20	WV10B-SE-4B-M20	124 110 530 1001
PG16	WV10B-SE-4B-PG16	124 110 530 1002

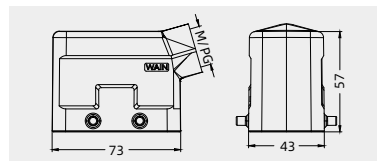

### Hoods, side entry, high construction



Thread	Designation	Order No.
M25	WV10B-SEH-4B-M25	124 110 530 5001
M32	WV10B-SEH-4B-M32	124 110 530 5002
PG21	WV10B-SEH-4B-PG21	124 110 530 5003
PG29	WV10B-SEH-4B-PG29	124 110 530 5004
	with sleeve	
M25	WV10B-SEH-4B-M25 <a href="#">WS</a>	124 110 530 5103
M32	WV10B-SEH-4B-M32 <a href="#">WS</a>	124 110 530 5104
PG21	WV10B-SEH-4B-PG21 <a href="#">WS</a>	124 110 530 5111
PG29	WV10B-SEH-4B-PG29 <a href="#">WS</a>	124 110 530 5112

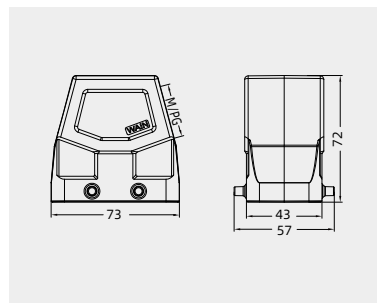

### Hoods, top entry



Thread	Designation	Order No.
M20	WV10B-TE-4B-M20	124 110 430 1001
PG16	WV10B-TE-4B-PG16	124 110 430 1002

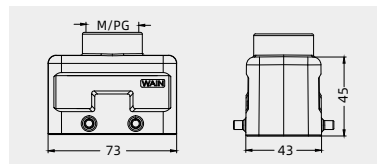

### Hoods, top entry, high construction



Thread	Designation	Order No.
M25	WV10B-TEH-4B-M25	124 110 430 5001
M32	WV10B-TEH-4B-M32	124 110 430 5002
PG21	WV10B-TEH-4B-PG21	124 110 430 5003
PG29	WV10B-TEH-4B-PG29	124 110 430 5004
	with sleeve	
M25	WV10B-TEH-4B-M25 <a href="#">WS</a>	124 110 430 5103
M32	WV10B-TEH-4B-M32 <a href="#">WS</a>	124 110 430 5104
PG21	WV10B-TEH-4B-PG21 <a href="#">WS</a>	124 110 430 5111
PG29	WV10B-TEH-4B-PG29 <a href="#">WS</a>	124 110 430 5112

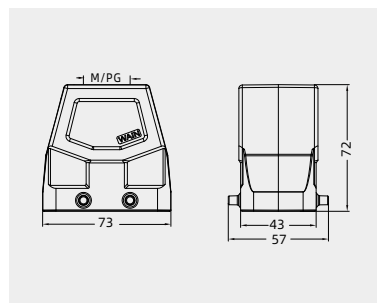

### Bulkhead mounted housings



Thread	Designation	Order No.
---	WV10B-BK-2L/SC	124 110 341 1101

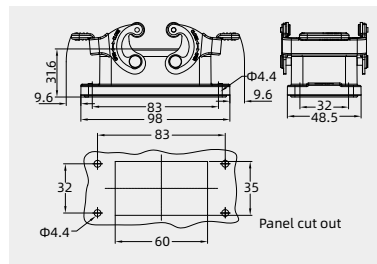

Please refer to page 15-02 for choosing proper model of lock.

10B Metal hoods/housings  
- for high voltage inserts(HVE Series)

Degree of protection: IP67

Housings, cable to cable



Thread	Designation	Order No.
M20	WV10B-CCT-2L/SC-M20	124 110 741 1001
PG16	WV10B-CCT-2L/SC-PG16	124 110 741 1002

Please refer to page 15-02 for choosing proper model of lock.

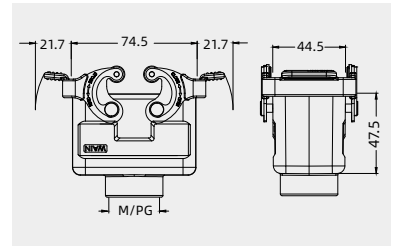

Housings, cable to cable, high construction



Thread	Designation	Order No.
M25	WV10B-CCTH-2L/SC-M25	124 110 741 5001
M32	WV10B-CCTH-2L/SC-M32	124 110 741 5002
PG21	WV10B-CCTH-2L/SC-PG21	124 110 741 5003
PG29	WV10B-CCTH-2L/SC-PG29 with sleeve	124 110 741 5004
M25	WV10B-CCTH-2L/SC-M25 WS	124 110 741 5103
M32	WV10B-CCTH-2L/SC-M32 WS	124 110 741 5104
PG21	WV10B-CCTH-2L/SC-PG21 WS	124 110 741 5111
PG29	WV10B-CCTH-2L/SC-PG29 WS	124 110 741 5112

Please refer to page 15-02 for choosing proper model of lock.

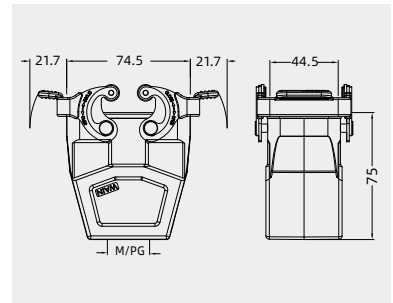

# 10B Metal hoods/housings - for high voltage inserts(HVE Series)

Degree of protection: IP67

## Hoods, side entry



Thread	Designation	Order No.
M20	WV10B-SE-2L/SC-M20	124 110 541 1001
PG16	WV10B-SE-2L/SC-PG16	124 110 541 1002

Please refer to page 15-02 for choosing proper model of lock.

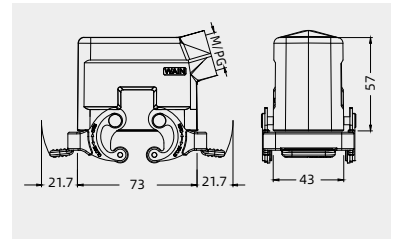

## Hoods, side entry, high construction



Thread	Designation	Order No.
M25	WV10B-SEH-2L/SC-M25	124 110 541 5001
M32	WV10B-SEH-2L/SC-M32	124 110 541 5002
PG21	WV10B-SEH-2L/SC-PG21	124 110 541 5003
PG29	WV10B-SEH-2L/SC-PG29	124 110 541 5004
	with sleeve	
M25	WV10B-SEH-2L/SC-M25 WS	124 110 541 5103
M32	WV10B-SEH-2L/SC-M32 WS	124 110 541 5104
PG21	WV10B-SEH-2L/SC-PG21 WS	124 110 541 5111
PG29	WV10B-SEH-2L/SC-PG29 WS	124 110 541 5012

Please refer to page 15-02 for choosing proper model of lock.

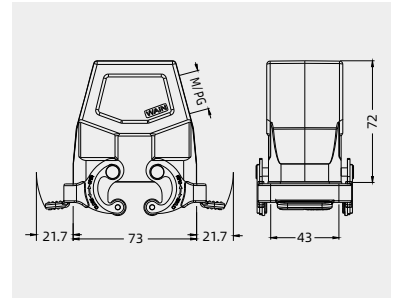

## Hoods, top entry



Thread	Designation	Order No.
M20	WV10B-TE-2L/SC-M20	124 110 441 1001
PG16	WV10B-TE-2L/SC-PG16	124 110 441 1002

Please refer to page 15-02 for choosing proper model of lock.

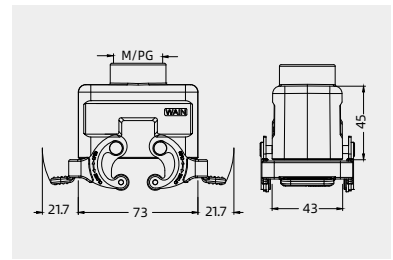

## Hoods, top entry, high construction



Thread	Designation	Order No.
M25	WV10B-TEH-2L/SC-M25	124 110 441 5001
M32	WV10B-TEH-2L/SC-M32	124 110 441 5002
PG21	WV10B-TEH-2L/SC-PG21	124 110 441 5003
PG29	WV10B-TEH-2L/SC-PG29	124 110 441 5004
	with sleeve	
M25	WV10B-TEH-2L/SC-M25 WS	124 110 441 5103
M32	WV10B-TEH-2L/SC-M32 WS	124 110 441 5104
PG21	WV10B-TEH-2L/SC-PG21 WS	124 110 441 5111
PG29	WV10B-TEH-2L/SC-PG29 WS	124 110 441 5112

Please refer to page 15-02 for choosing proper model of lock.

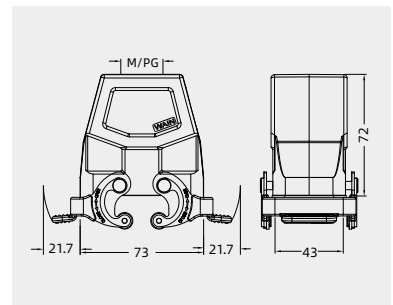

## Bulkhead mounted housings



Thread	Designation	Order No.
---	WV10B-BK-4B	124 110 330 1101

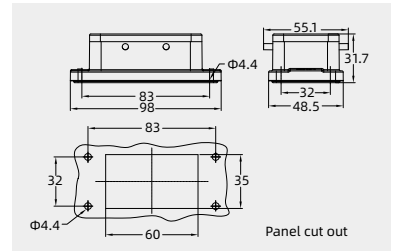



## 16B Plastic hoods/housings

Degree of protection: IP65

## Hoods, side entry, high construction



Thread	Designation	Order No.
M32	H16B.P-SEH-4B-M32	117 016 530 5004
M40	H16B.P-SEH-4B-M40	117 016 530 5005

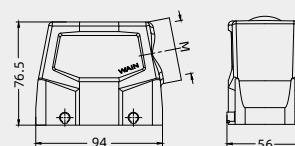

## Hoods, top entry, high construction



Thread	Designation	Order No.
M32	H16B.P-TEH-4B-M32	117 016 430 5004
M40	H16B.P-TEH-4B-M40	117 016 430 5005

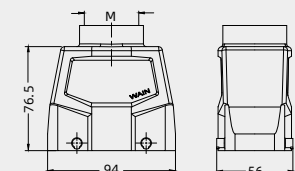

## Hoods, top entry, high construction



Thread	Designation	Order No.
2M25	H16B.P-TEH-4B-2M25	117 016 430 5002
2M32	H16B.P-TEH-4B-2M32	117 016 430 5001

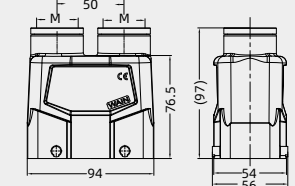

## Bulkhead mounted housings



Thread	Designation	Order No.
---	H16B.P-BK-2L	117 016 347 1001

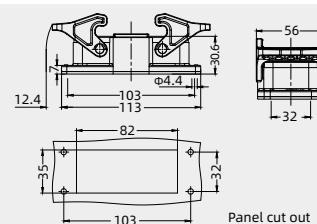

## Surface mounted housings, high construction



Thread	Designation	Order No.
M32	H16B.P-SFH-2L-M32	117 016 247 5004
2M32	H16B.P-SFH-2L-2M32	117 016 247 5024
M40	H16B.P-SFH-2L-M40	117 016 247 5005
2M40	H16B.P-SFH-2L-2M40	117 016 247 5025

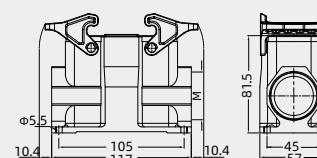

## Protection covers, for housings



Connect way	Designation	Order No.
---	H16B.P-CV-4B/2	117 016 030 8002

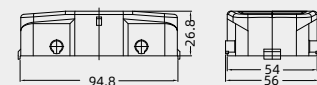

## Protection covers, for hoods



Connect way	Designation	Order No.
---	H16B.P-CV-2L/1	117 016 047 8001

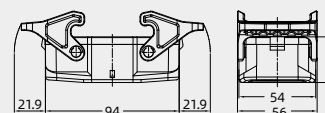

## 16B Plastic hoods/housings

Degree of protection: IP65



## Hoods, side entry, high construction



Thread	Designation	Order No.
M32	HM16B.P-SEH-4B-M32	129 016 530 1501
M40	HM16B.P-SEH-4B-M40	129 016 530 1500

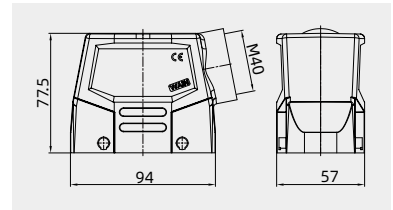

## Hoods, top entry, high construction



Thread	Designation	Order No.
M32	HM16B.P-TEH-4B-M32	1290164301501
M40	HM16B.P-TEH-4B-M40	1290164301500

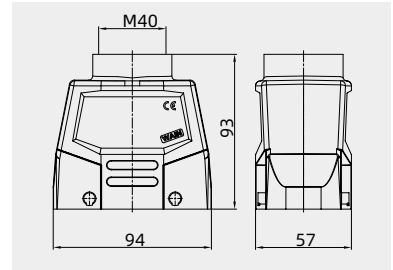

## Bulkhead mounted housings



Thread	Designation	Order No.
---	HM16B.P-BK-2L	129 0163 40 1500

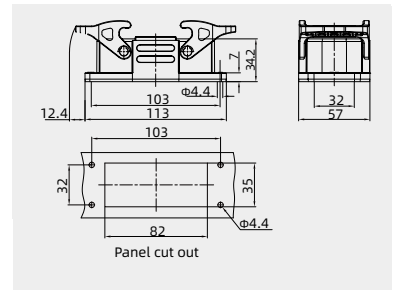

## Hoods, side entry, high construction



Thread	Designation	Order No.
M32	HM16B.P-SEH-2L-M40	129 016 547 1500
M40	HM16B.P-SEH-2L-M32	129 016 547 1501

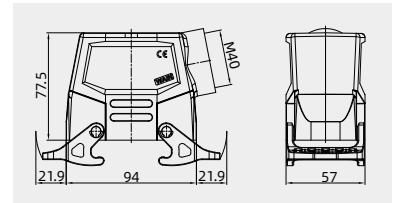

## Hoods, top entry, high construction



Thread	Designation	Order No.
M32	HM16B.P-TEH-2L-M32	129 016 447 1501
M40	HM16B.P-TEH-2L-M40	129 016 447 1500

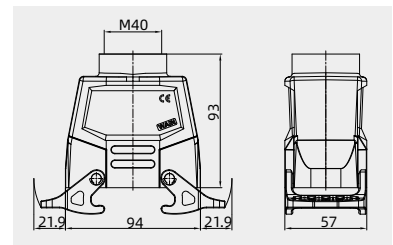

## Bulkhead mounted housings



Thread	Designation	Order No.
---	HM16B.P-BK-4B	129 016 330 1500

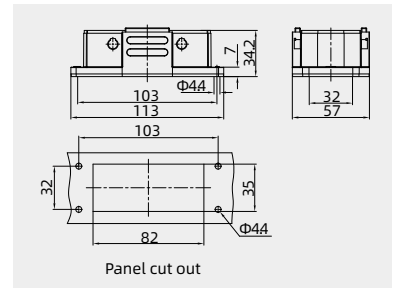

## 16B Metal hoods/housings

Degree of protection: IP65

## Hoods, side entry



Thread	Designation	Order No.
M25	H16B-SE-2B-M25	111 016 515 1003
M32	H16B-SE-2B-M32	111 016 515 1004
PG21	H16B-SE-2B-PG21	111 016 515 1011

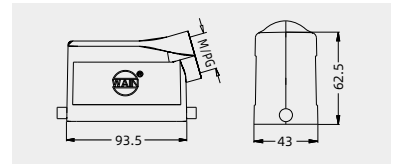

## Hoods, side entry, high construction



Thread	Designation	Order No.
---	W16B-BEH-2B	111 116 910 5002
M32	W16B-SEH-2B-M32	111 116 510 5001
M40	W16B-SEH-2B-M40	111 116 510 5002
PG21	W16B-SEH-2B-PG21	111 116 510 5003
PG29	W16B-SEH-2B-PG29	111 116 510 5004
	with sleeve	
M32	W16B-SEH-2B-M32 <i>WS</i>	111 116 515 5013
PG21	W16B-SEH-2B-PG21 <i>WS</i>	111 116 515 5011
PG29	W16B-SEH-2B-PG29 <i>WS</i>	111 116 515 5012

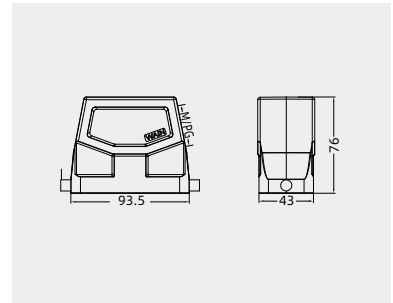

## Hoods, top entry



Thread	Designation	Order No.
M25	H16B-TE-2B-M25	111 016 415 1003
M32	H16B-TE-2B-M32	111 016 415 1004
PG21	H16B-TE-2B-PG21	111 016 415 1011

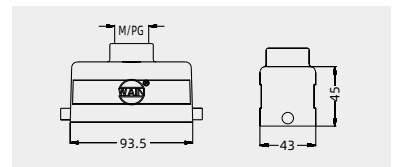

## Hoods, top entry, high construction



Thread	Designation	Order No.
---	W16B-BEH-2B	111 116 910 5002
M32	W16B-TEH-2B-M32	111 116 410 5001
M40	W16B-TEH-2B-M40	111 116 410 5002
PG21	W16B-TEH-2B-PG21	111 116 410 5003
PG29	W16B-TEH-2B-PG29	111 116 410 5004
	with sleeve	
M32	W16B-TEH-2B-M32 <i>WS</i>	111 116 415 5004
PG21	W16B-TEH-2B-PG21 <i>WS</i>	111 116 415 5011
PG29	W16B-TEH-2B-PG29 <i>WS</i>	111 116 415 5012

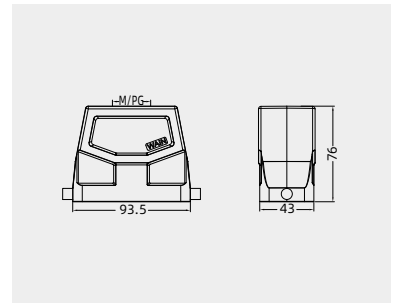

## 16B Metal hoods/housings

Degree of protection: IP65

## Housings, cable to cable



Thread	Designation	Order No.
M25	H16B-CCT-1L/SC-M25	111 016 721 1003
M32	H16B-CCT-1L/SC-M32	111 016 721 1004
PG21	H16B-CCT-1L/SC-PG21	111 016 721 1011

Please refer to page 15-02 for choosing proper model of lock.

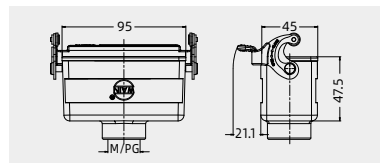

## Housings, cable to cable, high construction



Thread	Designation	Order No.
M32	W16B-CCTH-1L/SC-M32	111 116 721 5001
M40	W16B-CCTH-1L/SC-M40	111 116 721 5002
PG21	W16B-CCTH-1L/SC-PG21	111 116 721 5003
PG29	W16B-CCTH-1L/SC-PG29	111 116 721 5004
	with sleeve	
M32	W16B-CCTH-1L/SC-M32 WS	111 116 721 5008
PG21	W16B-CCTH-1L/SC-PG21 WS	111 116 721 5011
PG29	W16B-CCTH-1L/SC-PG29 WS	111 116 721 5012

Please refer to page 15-02 for choosing proper model of lock.

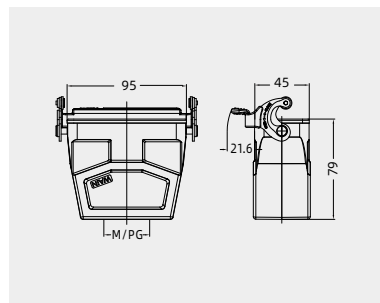

# 16B Metal hoods/housings

Degree of protection: IP65

## Bulkhead mounted housings



Thread	Designation	Order No.
---	H16B-BK-1L/SC	111 016 321 1001
with plastic cover		
---	H16B-BK-1L/SC-CV	111 016 361 1001
with metal cover		
---	H16B-BK-1L/SC-MCV	111 016 361 1101

Please refer to page 15-02 for choosing proper model of lock.

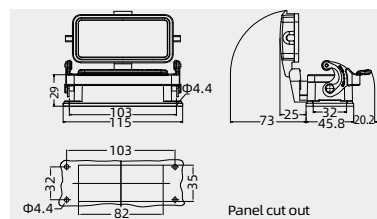

## BK hole cover plate



Applications	Designation	Order No.
---	16B-BK/MCV	111 016 300 1506

Panel cut out

The mounting hole of the mounting cabinet can be temporarily sealed. Applicable to the installation hole which has been opened, The case where the connector is not installed

## 16B Metal hoods/housings

Degree of protection: IP65

## Surface mounted housings



Thread	Designation	Order No.
M25	H16B-SF-1L/SC-M25	111 016 221 1003
2M25	H16B-SF-1L/SC-2M25	111 016 221 1023
PG21	H16B-SF-1L/SC-PG21	111 016 221 1011
2PG21	H16B-SF-1L/SC-2PG21	111 016 221 1031

## with plastic cover

M25	H16B-SF-1L/SC-CV-M25	111 016 261 1003
2M25	H16B-SF-1L/SC-CV-2M25	111 016 261 1023
PG21	H16B-SF-1L/SC-CV-PG21	111 016 261 1011
2PG21	H16B-SF-1L/SC-CV-2PG21	111 016 261 1031

## with metal cover

M25	H16B-SF-1L/SC-MCV-M25	111 016 261 1103
2M25	H16B-SF-1L/SC-MCV-2M25	111 016 261 1123
PG21	H16B-SF-1L/SC-MCV-PG21	111 016 261 1111
2PG21	H16B-SF-1L/SC-MCV-2PG21	111 016 261 1131

Please refer to page 15-02 for choosing proper model of lock.

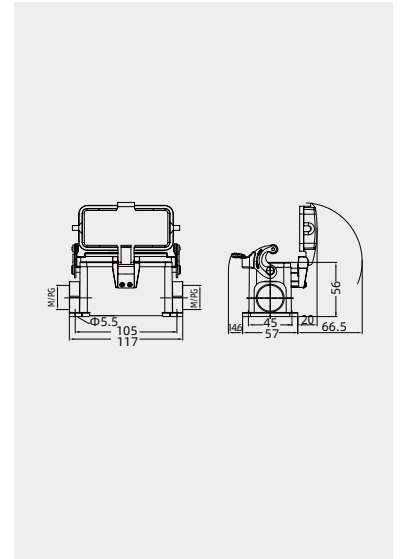

## Surface mounted housings, high construction



Thread	Designation	Order No.
M32	H16B-SFH-1L/SC-M32	111 016 221 5004
2M32	H16B-SFH-1L/SC-2M32	111 016 221 5024
PG21	H16B-SFH-1L/SC-PG21	111 016 221 5011
2PG21	H16B-SFH-1L/SC-2PG21	111 016 221 5031
PG29	H16B-SFH-1L/SC-PG29	111 016 221 5012
2PG29	H16B-SFH-1L/SC-2PG29	111 016 221 5032

## with plastic cover

M32	H16B-SFH-1L/SC-CV-M32	111 016 261 5004
2M32	H16B-SFH-1L/SC-CV-2M32	111 016 261 5024
PG21	H16B-SFH-1L/SC-CV-PG21	111 016 261 5011
2PG21	H16B-SFH-1L/SC-CV-2PG21	111 016 261 5031
PG29	H16B-SFH-1L/SC-CV-PG29	111 016 261 5012
2PG29	H16B-SFH-1L/SC-CV-2PG29	111 016 261 5032

## with metal cover

M32	H16B-SFH-1L/SC-MCV-M32	111 016 261 5104
2M32	H16B-SFH-1L/SC-MCV-2M32	111 016 261 5124
PG21	H16B-SFH-1L/SC-MCV-PG21	111 016 261 5111
2PG21	H16B-SFH-1L/SC-MCV-2PG21	111 016 261 5131
PG29	H16B-SFH-1L/SC-MCV-PG29	111 016 261 5112
2PG29	H16B-SFH-1L/SC-MCV-2PG29	111 016 261 5132

Please refer to page 15-02 for choosing proper model of lock.

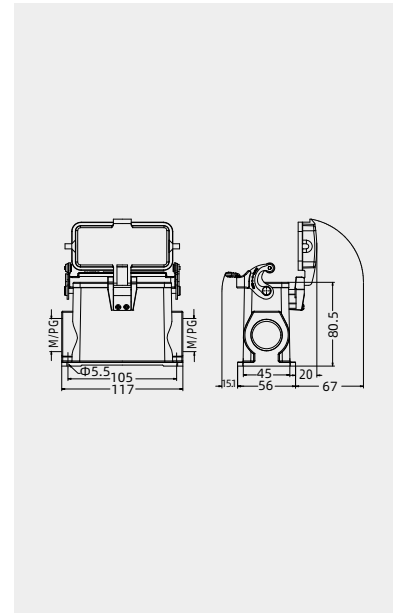

## 16B Metal hoods/housings

Degree of protection: IP65

## Hoods, side entry



Thread	Designation	Order No.
M25	H16B-SE-4B-M25	111 016 530 1003
M32	H16B-SE-4B-M32	111 016 530 1004
PG21	H16B-SE-4B-PG21	111 016 530 1011

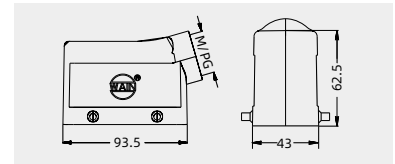

## Hoods, side entry, high construction



Thread	Designation	Order No.
---	W16B-BEH-4B	111 116 930 5003
M32	W16B-SEH-4B-M32	111 116 530 5001
M40	W16B-SEH-4B-M40	111 116 530 5002
PG21	W16B-SEH-4B-PG21	111 116 530 5003
PG29	W16B-SEH-4B-PG29	111 116 530 5004
	with sleeve	
M32	W16B-SEH-4B-M32 <a href="#">WS</a>	111 116 530 5014
PG21	W16B-SEH-4B-PG21 <a href="#">WS</a>	111 116 530 5011
PG29	W16B-SEH-4B-PG29 <a href="#">WS</a>	111 116 530 5012

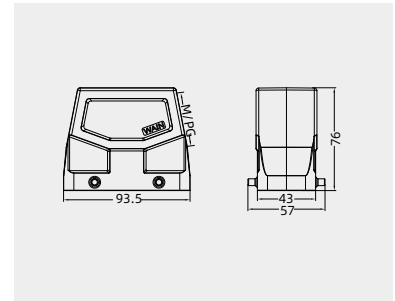

## Hoods, top entry



Thread	Designation	Order No.
M25	H16B-TE-4B-M25	111 016 430 1003
M32	H16B-TE-4B-M32	111 016 430 1004
PG21	H16B-TE-4B-PG21	111 016 430 1011

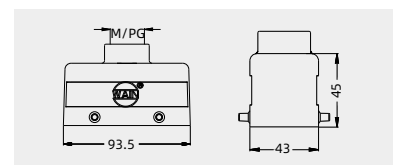

## Hoods, top entry, high construction



Thread	Designation	Order No.
---	W16B-BEH-4B	111 116 930 5003
M32	W16B-TEH-4B-M32	111 116 430 5001
M40	W16B-TEH-4B-M40	111 116 430 5002
PG21	W16B-TEH-4B-PG21	111 116 430 5003
PG29	W16B-TEH-4B-PG29	111 116 430 5004
	with sleeve	
M32	W16B-TEH-4B-M32 <a href="#">WS</a>	111 116 430 5022
PG21	W16B-TEH-4B-PG21 <a href="#">WS</a>	111 116 430 5020
PG29	W16B-TEH-4B-PG29 <a href="#">WS</a>	111 116 430 5021

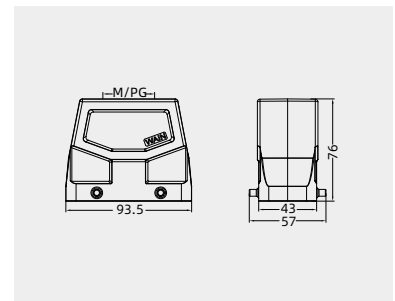

## 16B Metal hoods/housings

Degree of protection: IP65

## Bulkhead mounted housings



Thread	Designation	Order No.
---	H16B-BK-2L/SC	111 016 341 1001

Please refer to page 15-02 for choosing proper model of lock.

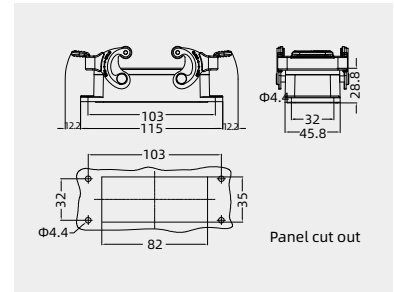

## Surface mounted housings



Thread	Designation	Order No.
M25	H16B-SF-2L/SC-M25	111 016 241 1003
2M25	H16B-SF-2L/SC-2M25	111 016 241 1023
PG21	H16B-SF-2L/SC-PG21	111 016 241 1011
2PG21	H16B-SF-2L/SC-2PG21	111 016 241 1031

Please refer to page 15-02 for choosing proper model of lock.

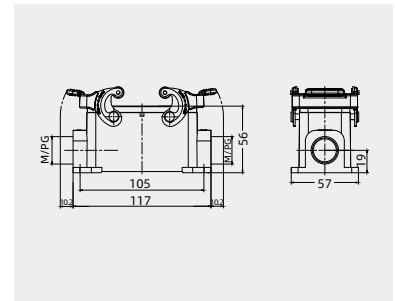

## Surface mounted housings, high construction



Thread	Designation	Order No.
M25	H16B-SFH-2L/SC-M25	111 016 241 5003
M32	H16B-SFH-2L/SC-M32	111 016 241 5004
2M32	H16B-SFH-2L/SC-2M32	111 016 241 5024
M40	H16B-SFH-2L/SC-M40	111 016 241 5005
2M40	H16B-SFH-2L/SC-2M40	111 016 241 5025
PG21	H16B-SFH-2L/SC-PG21	111 016 241 5011
2PG21	H16B-SFH-2L/SC-2PG21	111 016 241 5031
PG29	H16B-SFH-2L/SC-PG29	111 016 241 5012
2PG29	H16B-SFH-2L/SC-2PG29	111 016 241 5032

Please refer to page 15-02 for choosing proper model of lock.

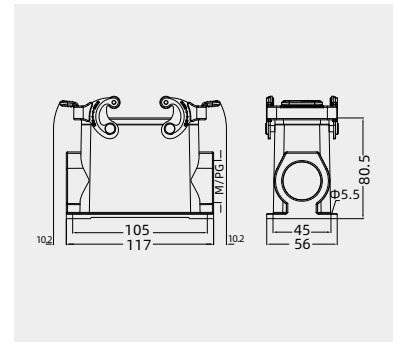

## Housings, cable to cable



Thread	Designation	Order No.
M25	H16B-CCT-2L/SC-M25	111 016 741 1003
M32	H16B-CCT-2L/SC-M32	111 016 741 1004
PG21	H16B-CCT-2L/SC-PG21	111 016 741 1011

Please refer to page 15-02 for choosing proper model of lock.

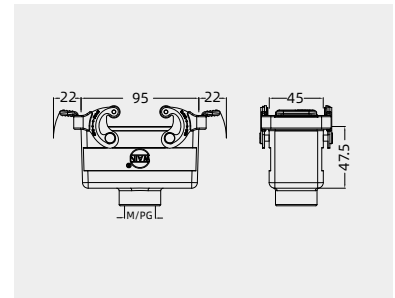



## 16B Metal hoods/housings

Degree of protection: IP65

Housings, cable to cable, high construction



Thread	Designation	Order No.
M25	W16B-CCTH-2L/SC-M25	111 116 741 5002
M32	W16B-CCTH-2L/SC-M32	111 116 741 5003
M40	W16B-CCTH-2L/SC-M40	111 116 741 5004
PG21	W16B-CCTH-2L/SC-PG21	111 116 741 5005
PG29	W16B-CCTH-2L/SC-PG29	111 116 741 5006
	with sleeve	
M32	W16B-CCTH-2L/SC-M32 WS	111 116 741 5013
PG21	W16B-CCTH-2L/SC-PG21 WS	111 116 741 5011
PG29	W16B-CCTH-2L/SC-PG29 WS	111 116 741 5012

Please refer to page 15-02 for choosing proper model of lock.

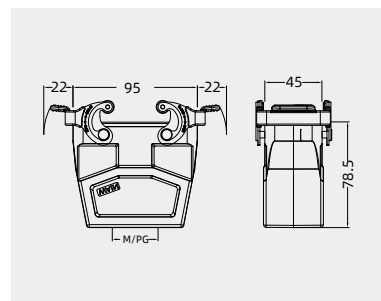

Protection covers, plastic



Thread	Applications	Designation	Order No.
---	for hoods	H16B-CV-4C	111 016 090 8009

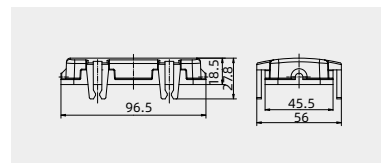

Protection covers, plastic



Connect way	Applications	Designation	Order No.
	for Housings, cable to cable	H16B-CV-4B/1	111 016 030 8001
	for Housings, bulkhead mounting /surface mounting	H16B-CV-4B/2	111 016 030 8002

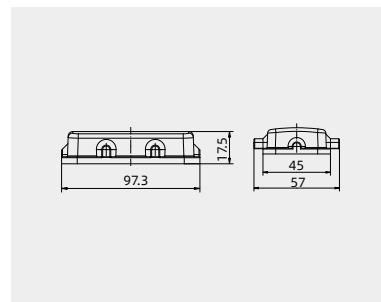

# 16B Metal hoods/housings

Degree of protection: IP65

## Hoods, side entry



Thread	Designation	Order No.
M25	H16B-SE-2L/SC-M25	111 016 541 1003
M32	H16B-SE-2L/SC-M32	111 016 541 1004
PG21	H16B-SE-2L/SC-PG21	111 016 541 1011

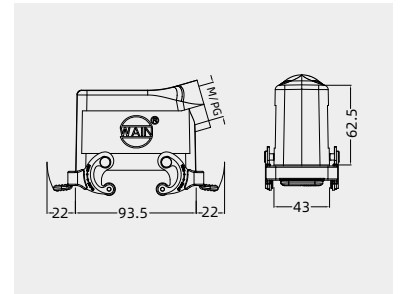

Please refer to page 15-02 for choosing proper model of lock.

## Hoods, side entry, high construction



Thread	Designation	Order No.
M32	W16B-SEH-2L/SC-M32	111 116 541 5001
M40	W16B-SEH-2L/SC-M40	111 116 541 5002
PG21	W16B-SEH-2L/SC-PG21	111 116 541 5003
PG29	W16B-SEH-2L/SC-PG29	111 116 541 5004
	with sleeve	
M32	W16B-SEH-2L/SC-M32 WS	111 116 541 5005
PG21	W16B-SEH-2L/SC-PG21 WS	111 116 541 5011
PG29	W16B-SEH-2L/SC-PG29 WS	111 116 541 5006

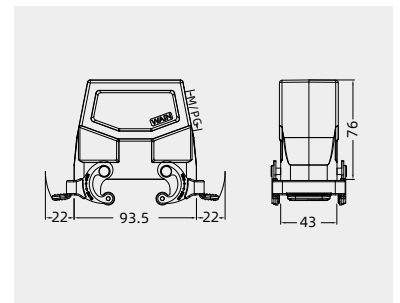

Please refer to page 15-02 for choosing proper model of lock.

## Hoods, top entry



Thread	Designation	Order No.
M25	H16B-TE-2L/SC-M25	111 016 441 1003
M32	H16B-TE-2L/SC-M32	111 016 441 1004
PG21	H16B-TE-2L/SC-PG21	111 016 441 1011

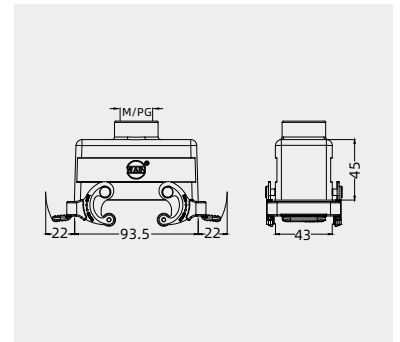

Please refer to page 15-02 for choosing proper model of lock.

## Hoods, top entry, high construction



Thread	Designation	Order No.
M32	W16B-TEH-2L/SC-M32	111 116 441 5001
M40	W16B-TEH-2L/SC-M40	111 116 441 5002
PG21	W16B-TEH-2L/SC-PG21	111 116 441 5003
PG29	W16B-TEH-2L/SC-PG29	111 116 441 5004
	with sleeve	
M32	W16B-TEH-2L/SC-M32 WS	111 116 441 5009
PG21	W16B-TEH-2L/SC-PG21 WS	111 116 441 5011
PG29	W16B-TEH-2L/SC-PG29 WS	111 116 441 5012

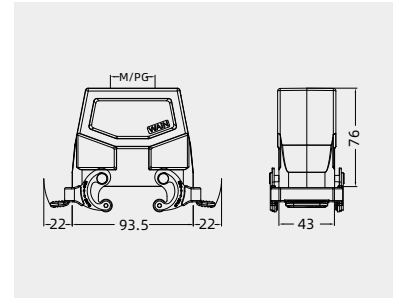

Please refer to page 15-02 for choosing proper model of lock.

## Bulkhead mounted housings



Thread	Designation	Order No.
---	H16B-BK-4B	111 016 330 1001
	with plastic cover	
---	H16B-BK-4B-CV	111 016 370 1001
	with metal cover	
---	H16B-BK-4B-MCV	111 016 370 1101

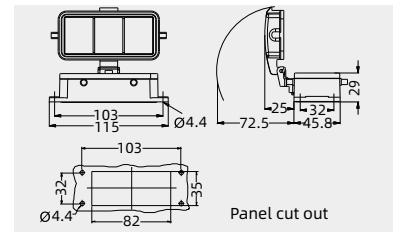

16B Metal hoods/housings

Degree of protection: IP65

Surface mounted housings



Thread	Designation	Order No.
M25	H16B-SF-4B-M25	111 016 230 1003
2M25	H16B-SF-4B-2M25	111 016 230 1023
PG21	H16B-SF-4B-PG21	111 016 230 1011
2PG21	H16B-SF-4B-2PG21	111 016 230 1031
with plastic cover		
M25	H16B-SF-4B-CV-M25	111 016 270 1003
2M25	H16B-SF-4B-CV-2M25	111 016 270 1023
PG21	H16B-SF-4B-CV-PG21	111 016 270 1011
2PG21	H16B-SF-4B-CV-2PG21	111 016 270 1031
with metal cover		
M25	H16B-SF-4B-MCV-M25	111 016 270 1103
2M25	H16B-SF-4B-MCV-2M25	111 016 270 1123
PG21	H16B-SF-4B-MCV-PG21	111 016 270 1111
2PG21	H16B-SF-4B-MCV-2PG21	111 016 270 1131

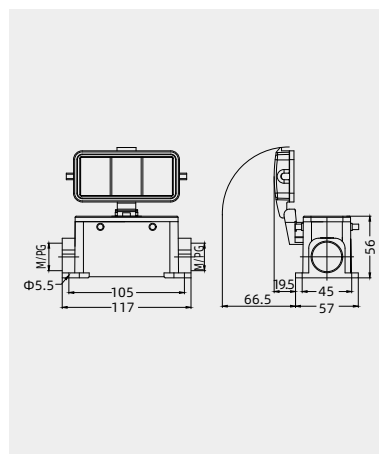

Surface mounted housings, high construction



Thread	Designation	Order No.
M32	H16B-SFH-4B-M32	111 016 230 5004
2M32	H16B-SFH-4B-2M32	111 016 230 5024
PG21	H16B-SFH-4B-PG21	111 016 230 5011
2PG21	H16B-SFH-4B-2PG21	111 016 230 5031
PG29	H16B-SFH-4B-PG29	111 016 230 5012
2PG29	H16B-SFH-4B-2PG29	111 016 230 5032
with plastic cover		
M32	H16B-SFH-4B-CV-M32	111 016 270 5004
2M32	H16B-SFH-4B-CV-2M32	111 016 270 5024
PG21	H16B-SFH-4B-CV-PG21	111 016 270 5011
2PG21	H16B-SFH-4B-CV-2PG21	111 016 270 5031
PG29	H16B-SFH-4B-CV-PG29	111 016 270 5012
2PG29	H16B-SFH-4B-CV-2PG29	111 016 270 5032
with metal cover		
M32	H16B-SFH-4B-MCV-M32	111 016 270 5104
2M32	H16B-SFH-4B-MCV-2M32	111 016 270 5124
PG21	H16B-SFH-4B-MCV-PG21	111 016 270 5111
2PG21	H16B-SFH-4B-MCV-2PG21	111 016 270 5131
PG29	H16B-SFH-4B-MCV-PG29	111 016 270 5112
2PG29	H16B-SFH-4B-MCV-2PG29	111 016 270 5132

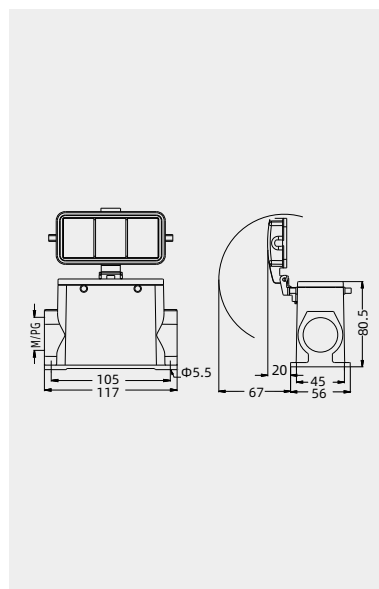

Protection covers, metal



Connect way	Applications	Designation	Order No.
	for hoods	H16B-MCV-4B/1S	111 016 030 8103
	for housings, without sealing	H16B-MCV-4B/2	111 016 030 8102

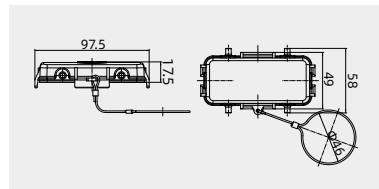

Protection covers, metal



Connect way	Applications	Designation	Order No.
	for hoods	H16B-MCV-2L/SC.1S	111 016 041 8101
	for housings,	H16B-MCV-2L/SC.2	111 016 041 8102

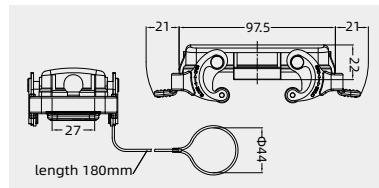

Please refer to page 15-02 for choosing proper model of lock.

## 16B Metal hoods/housings

Degree of protection: IP65

### Protection covers, metal



Connect way	Applications	Designation	Order No.
	for hoods	H16B-MCV-1L/SC.1S	111 016 021 8001

Please refer to page 15-02 for choosing proper model of lock.

### Protection covers(IP5X)



Thread	Applications	Designation	Order No.
---	for housings	H16B-CV/C	111 016 000 8002

### Hoods, side entry, high construction



Thread	Designation	Order No.
M25	W16B-SEH-1L/C-M25	111 116 550 5001
M32	W16B-SEH-1L/C-M32	111 116 550 5002
PG21	W16B-SEH-1L/C-PG21	111 116 550 5003
PG29	W16B-SEH-1L/C-PG29	111 116 550 5004
	with sleeve	
M32	W16B-SEH-1L/C-M32 <i>WS</i>	111 116 555 5004
PG21	W16B-SEH-1L/C-PG21 <i>WS</i>	111 116 555 5001
PG29	W16B-SEH-1L/C-PG29 <i>WS</i>	111 116 555 5002

### Bulkhead mounted housings



Thread	Designation	Order No.
---	H16B-BK-2B/C	111 016 355 1001

## stainless steel hoods/housings

Degree of protection: IP67

### Hoods, side entry, high construction



Thread	Designation	Order No.
PG29	W16B.S-SEH-4B-PG29	111 116 530 5528

### Bulkhead mounted housings



Thread	Designation	Order No.
---	W16B.S-BK-2L/SCN	111 116 341 1006

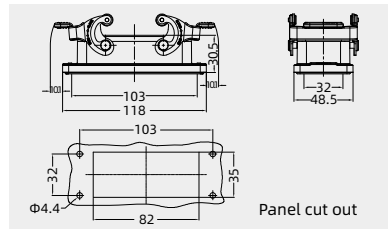
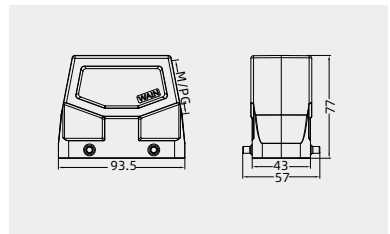
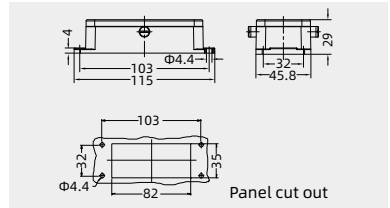
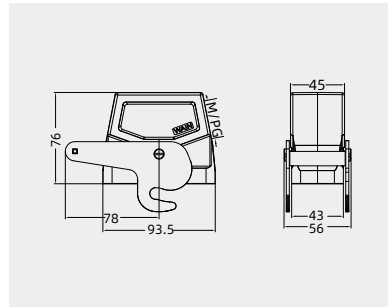
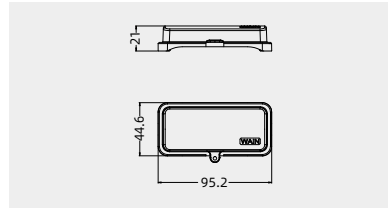
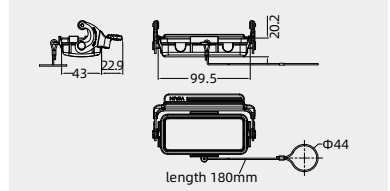

## 16B Metal hoods/housings -Suitable for harsh environment(anti-corrosion)

Degree of protection: IP65

### Hoods, side entry



Thread	Designation	Order No.
M25	H16B-MSE-4B-M25	112 016 530 1003
M32	H16B-MSE-4B-M32	112 016 530 1004
PG21	H16B-MSE-4B-PG21	112 016 530 1011

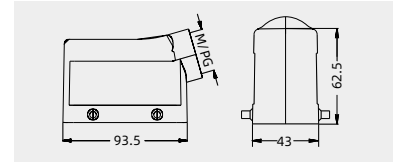

### Hoods, side entry, high construction



Thread	Designation	Order No.
M32	W16B-MSEH-4B-M32	112 116 530 5005
M40	W16B-MSEH-4B-M40	112 116 530 5006
PG21	W16B-MSEH-4B-PG21	112 116 530 5011
PG29	W16B-MSEH-4B-PG29 with sleeve	112 116 530 5007
M32	W16B-MSEH-4B-M32 <b>WS</b>	112 116 530 5004
PG21	W16B-MSEH-4B-PG21 <b>WS</b>	112 116 530 5001
PG29	W16B-MSEH-4B-PG29 <b>WS</b>	112 116 530 5012

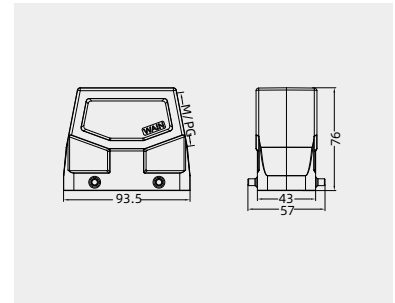

### Hoods, top entry



Thread	Designation	Order No.
M25	H16B-MTE-4B-M25	112 016 430 1003
M32	H16B-MTE-4B-M32	112 016 430 1004
PG21	H16B-MTE-4B-PG21	112 016 430 1011

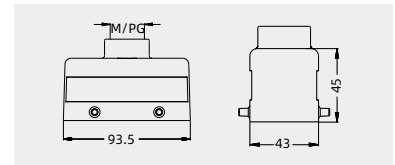

### Hoods, top entry, high construction



Thread	Designation	Order No.
M32	W16B-MTEH-4B-M32	112 116 430 5005
M40	W16B-MTEH-4B-M40	112 116 430 5001
PG21	W16B-MTEH-4B-PG21	112 116 430 5011
PG29	W16B-MTEH-4B-PG29 with sleeve	112 116 430 5006
M32	W16B-MTEH-4B-M32 <b>WS</b>	112 116 430 5007
PG21	W16B-MTEH-4B-PG21 <b>WS</b>	112 116 430 5008
PG29	W16B-MTEH-4B-PG29 <b>WS</b>	112 116 430 5012

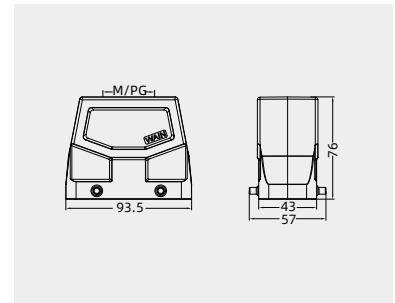

### Bulkhead mounted housings



Thread	Designation	Order No.
---	H16B-MBK-2L/SC	112 016 341 1001

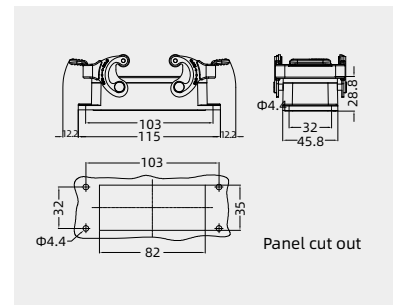

### Surface mounted housings



Thread	Designation	Order No.
M25	H16B-MSF-2L/SC-M25	112 016 241 1003
2M25	H16B-MSF-2L/SC-2M25	112 016 241 1023
PG21	H16B-MSF-2L/SC-PG21	112 016 241 1011

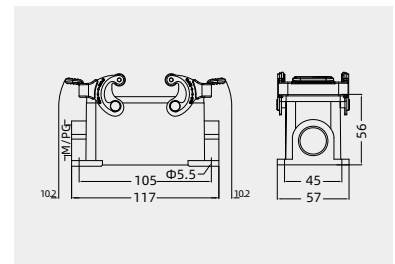

16B Metal hoods/housings  
-Suitable for harsh environment(anti-corrosion)

Degree of protection: IP65

Surface mounted housings, high construction



Thread	Designation	Order No.
M32	H16B-MSFH-2L/SC-M32	112 016 241 5004
2M32	H16B-MSFH-2L/SC-2M32	112 016 241 5024
M40	H16B-MSFH-2L/SC-M40	112 016 241 5005
2M40	H16B-MSFH-2L/SC-2M40	112 016 241 5025
PG21	H16B-MSFH-2L/SC-PG21	112 016 241 5011
2PG21	H16B-MSFH-2L/SC-2PG21	112 016 241 5031
PG29	H16B-MSFH-2L/SC-PG29	112 016 241 5012
2PG29	H16B-MSFH-2L/SC-2PG29	112 016 241 5032

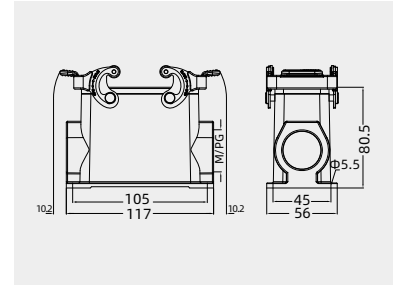

Housings, cable to cable



Thread	Designation	Order No.
M25	H16B-MCCT-2L/SC-M25	112 016 741 1003
M32	H16B-MCCT-2L/SC-M32	112 010 741 1004
PG21	H16B-MCCT-2L/SC-PG21	112 016 741 1011

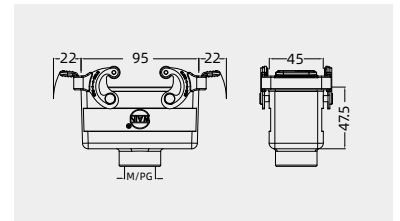

Protection covers



Connect way	Applications	Designation	Order No.
	for hoods	H16B-MMCV-4B/1	112 016 030 8001
	for housings	H16B-MMCV-4B/2	112 016 030 8002

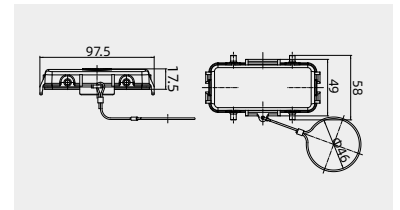

Protection covers



Connect way	Applications	Designation	Order No.
	for hoods	H16B-MMCV-2L/SC.1S	112 016 041 8001
	for housings	H16B-MMCV-2L/SC.2	112 016 041 8002

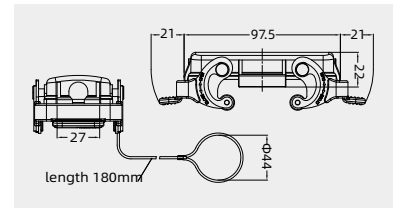

Degree of protection: IP65

Hoods, side entry, high construction



Thread	Designation	Order No.
M32	W16B-MSEH-1L/C-M32	112 116 550 5005
PG21	W16B-MSEH-1L/C-PG21	112 116 550 5006
PG29	W16B-MSEH-1L/C-PG29	112 116 550 5007
	with sleeve	
M32	W16B-MSEH-1L/C-M32 WS	112 116 555 5004
PG21	W16B-MSEH-1L/C-PG21 WS	112 116 555 5011
PG29	W16B-MSEH-1L/C-PG29 WS	112 116 555 5012

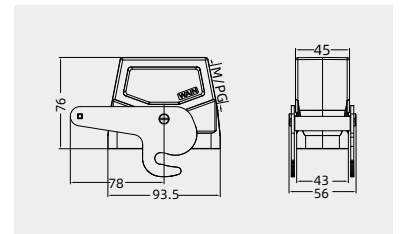

Bulkhead mounted housings



Thread	Designation	Order No.
---	H16B-MBK-2B/C	112 016 350 1001

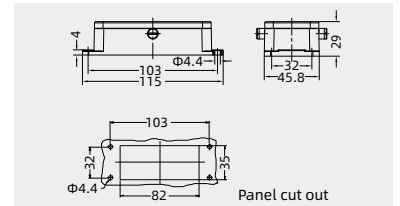

## 16B EMC Metal hoods/housings

Degree of protection: IP65

## Hoods, side entry



Thread	Designation	Order No.
M25	EMC.H16B-SE-4B-M25	111 616 535 1501
M32	EMC.H16B-SE-4B-M32	111 616 530 1001
PG21	EMC.H16B-SE-4B-PG21	111 616 535 1011

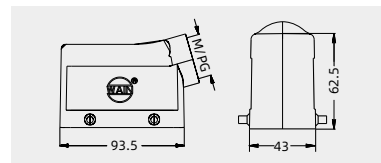

## Hoods, side entry, high construction



Thread	Designation	Order No.
---	EMC.W16B-BEH-4B	111 216 930 5004
M32	EMC.W16B-SEH-4B-M32	111 216 530 5008
M40	EMC.W16B-SEH-4B-M40	111 216 530 5009
PG21	EMC.W16B-SEH-4B-PG21	111 116 535 5014
PG29	EMC.W16B-SEH-4B-PG29	111 216 530 5010
M32	EMC.W16B-SEH-4B-M32 <a href="#">WS</a>	111 116 535 5002
PG21	EMC.W16B-SEH-4B-PG21 <a href="#">WS</a>	111 216 535 5506
PG29	EMC.W16B-SEH-4B-PG29 <a href="#">WS</a>	111 116 535 5003

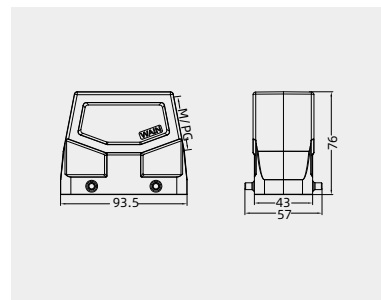

## Hoods, top entry



Thread	Designation	Order No.
M25	EMC.H16B-TE-4B-M25	111 616 435 1003
M32	EMC.H16B-TE-4B-M32	111 616 435 1004
PG21	EMC.H16B-TE-4B-PG21	111 616 435 1011

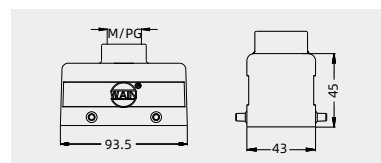

## Hoods, top entry, high construction



Thread	Designation	Order No.
---	EMC.W16B-BEH-4B	111 216 930 5004
M32	EMC.W16B-TEH-4B-M32	111 216 430 5007
M40	EMC.W16B-TEH-4B-M40	111 216 430 5008
PG21	EMC.W16B-TEH-4B-PG21	111 216 430 5012
PG29	EMC.W16B-TEH-4B-PG29	111 216 430 5009
M32	EMC.W16B-TEH-4B-M32 <a href="#">WS</a>	111 116 435 5004
PG21	EMC.W16B-TEH-4B-PG21 <a href="#">WS</a>	111 216 430 5010
PG29	EMC.W16B-TEH-4B-PG29 <a href="#">WS</a>	111 116 435 5002

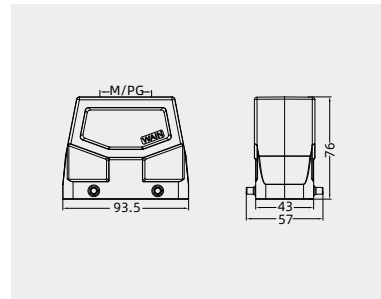

## Bulkhead mounted housings



Thread	Designation	Order No.
---	EMC1.H16B-BK-2L/ <a href="#">SC</a>	111 616 341 1201

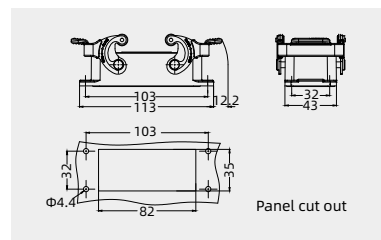

Please refer to page 15-02 for choosing proper model of lock.

16B EMC Metal hoods/housings

Degree of protection: IP65



Hoods, side entry



Thread	Designation	Order No.
M25	EMC.H16B-SF-2L/SC-M25	111 616 241 1500
2M25	EMC.H16B-SF-2L/SC-2M25	111 616 241 1501
PG21	EMC.H16B-SF-2L/SC-PG21	111 616 241 1502
2PG21	EMC.H16B-SF-2L/SC-2PG21	111 616 241 1503

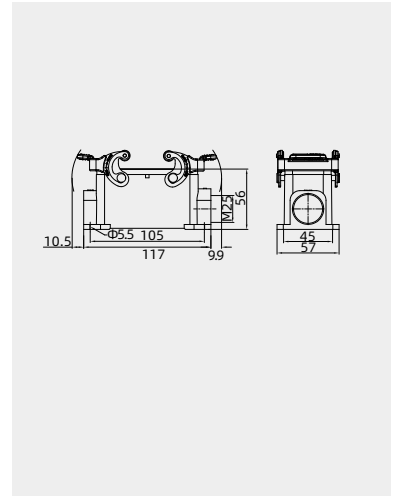

H

Hoods, side entry, high construction



Thread	Designation	Order No.
M32	EMC.H16B-SFH-2L/SC-M32	111 616 241 5500
2M32	EMC.H16B-SFH-2L/SC-2M32	111 616 241 5501
M40	EMC.H16B-SFH-2L/SC-M40	111 616 241 5502
2M40	EMC.H16B-SFH-2L/SC-2M40	111 616 241 5503
PG21	EMC.H16B-SFH-2L/SC-PG21	111 616 241 5504
2PG21	EMC.H16B-SFH-2L/SC-2PG21	111 616 241 5505
PG29	EMC.H16B-SFH-2L/SC-PG29	111 616 241 5506
2PG29	EMC.H16B-SFH-2L/SC-2PG29	111 616 241 5507

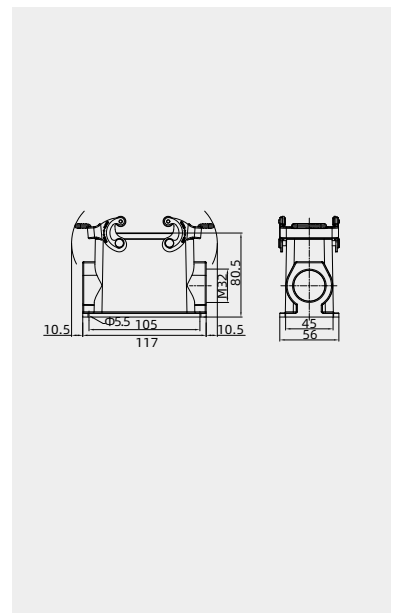



## 16B Metal hoods/housings

Degree of protection: IP67

## Hoods, side entry



Thread	Designation	Order No.
M25	W16B-SE-2B-M25	111 116 510 1001
M32	W16B-SE-2B-M32	111 116 510 1002
PG21	W16B-SE-2B-PG21	111 116 510 1003

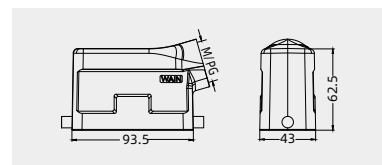

## Hoods, side entry, high construction



Thread	Designation	Order No.
---	W16B-BEH-2B	111 116 910 5002
M32	W16B-SEH-2B-M32	111 116 510 5001
M40	W16B-SEH-2B-M40	111 116 510 5002
PG21	W16B-SEH-2B-PG21	111 116 510 5003
PG29	W16B-SEH-2B-PG29	111 116 510 5004
	with sleeve	
M32	W16B-SEH-2B-M32 <a href="#">WS</a>	111 116 515 5013
PG21	W16B-SEH-2B-PG21 <a href="#">WS</a>	111 116 515 5011
PG29	W16B-SEH-2B-PG29 <a href="#">WS</a>	111 116 515 5012

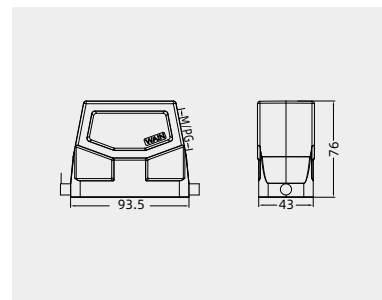

## Hoods, top entry



Thread	Designation	Order No.
M25	W16B-TE-2B-M25	111 116 410 1001
M32	W16B-TE-2B-M32	111 116 410 1002
PG21	W16B-TE-2B-PG21	111 116 410 1003

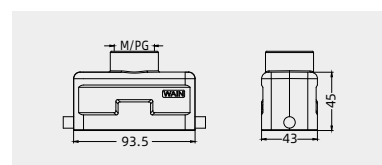

## Hoods, top entry, high construction



Thread	Designation	Order No.
---	W16B-BEH-2B	111 116 910 5002
M32	W16B-TEH-2B-M32	111 116 410 5001
M40	W16B-TEH-2B-M40	111 116 410 5002
PG21	W16B-TEH-2B-PG21	111 116 410 5003
PG29	W16B-TEH-2B-PG29	111 116 410 5004
	with sleeve	
M32	W16B-TEH-2B-M32 <a href="#">WS</a>	111 116 415 5004
PG21	W16B-TEH-2B-PG21 <a href="#">WS</a>	111 116 415 5011
PG29	W16B-TEH-2B-PG29 <a href="#">WS</a>	111 116 415 5012

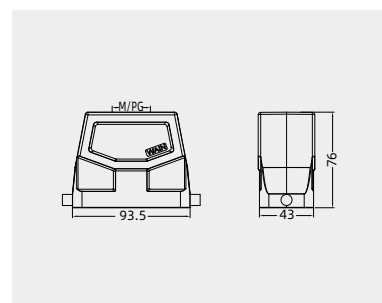

## 16B Metal hoods/housings

Degree of protection: IP67

Housings, cable to cable



Thread	Designation	Order No.
M25	W16B-CCT-1L/SC-M25	111 116 721 1002
M32	W16B-CCT-1L/SC-M32	111 116 721 1003
PG21	W16B-CCT-1L/SC-PG21	111 116 721 1004

Please refer to page 15-02 for choosing proper model of lock.

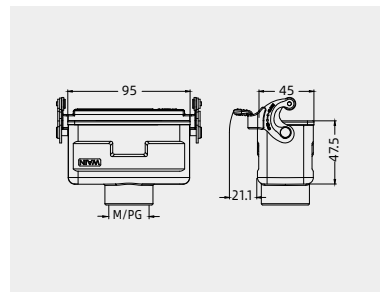

Housings, cable to cable, high construction



Thread	Designation	Order No.
M32	W16B-CCTH-1L/SC-M32	111 116 721 5001
M40	W16B-CCTH-1L/SC-M40	111 116 721 5002
PG21	W16B-CCTH-1L/SC-PG21	111 116 721 5003
PG29	W16B-CCTH-1L/SC-PG29	111 116 721 5004
	with sleeve	
M32	W16B-CCTH-1L/SC-M32 WS	111 116 721 5008
PG21	W16B-CCTH-1L/SC-PG21 WS	111 116 721 5011
PG29	W16B-CCTH-1L/SC-PG29 WS	111 116 721 5012

Please refer to page 15-02 for choosing proper model of lock.

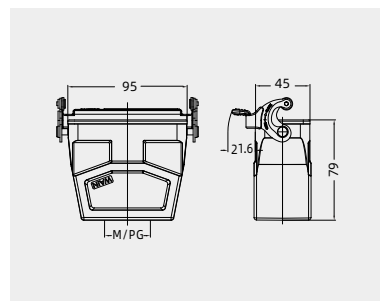

Bulkhead mounted housings



Thread	Designation	Order No.
---	W16B-BK-1L/SC	111 116 321 1001
	with plastic cover	
---	W16B-BK-1L/SC-CV	111 116 321 8001
	with metal cover	
---	W16B-BK-1L/SC-MCV	111 116 321 8002

Please refer to page 15-02 for choosing proper model of lock.

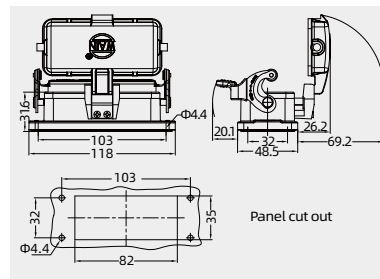

## 16B Metal hoods/housings

Degree of protection: IP67

## Hoods, side entry



Thread	Designation	Order No.
M25	W16B-SE-4B-M25	111 116 530 1001
M32	W16B-SE-4B-M32	111 116 530 1002
PG21	W16B-SE-4B-PG21	111 116 530 1003

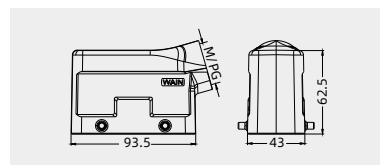

## Hoods, side entry, high construction



Thread	Designation	Order No.
---	W16B-BEH-4B	111 116 930 5003
M32	W16B-SEH-4B-M32	111 116 530 5001
M40	W16B-SEH-4B-M40	111 116 530 5002
PG21	W16B-SEH-4B-PG21	111 116 530 5003
PG29	W16B-SEH-4B-PG29	111 116 530 5004
	with sleeve	
M32	W16B-SEH-4B-M32 <i>WS</i>	111 116 530 5014
PG21	W16B-SEH-4B-PG21 <i>WS</i>	111 116 530 5011
PG29	W16B-SEH-4B-PG29 <i>WS</i>	111 116 530 5012

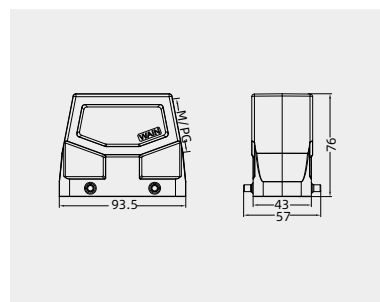

## Hoods, side entry, high construction

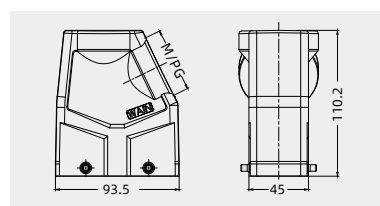

Thread	Designation	Order No.
M50	W16B-SEH-4B-M50	111 116 530 5006
PG36	W16B-SEH-4B-PG36	111 116 530 5013

Suitable for cable with maximum OD  $\phi$ 32mm

## Hoods, top entry



Thread	Designation	Order No.
M25	W16B-TE-4B-M25	111 116 430 1001
M32	W16B-TE-4B-M32	111 116 430 1002
PG21	W16B-TE-4B-PG21	111 116 430 1003

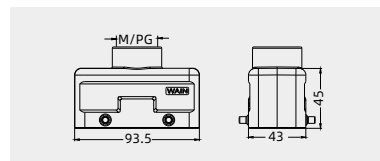

## Hoods, top entry, high construction



Thread	Designation	Order No.
---	W16B-BEH-4B	111 116 930 5003
M32	W16B-TEH-4B-M32	111 116 430 5001
M40	W16B-TEH-4B-M40	111 116 430 5002
PG21	W16B-TEH-4B-PG21	111 116 430 5003
PG29	W16B-TEH-4B-PG29	111 116 430 5004
	with sleeve	
M32	W16B-TEH-4B-M32 <i>WS</i>	111 116 430 5022
PG21	W16B-TEH-4B-PG21 <i>WS</i>	111 116 430 5020
PG29	W16B-TEH-4B-PG29 <i>WS</i>	111 116 430 5021

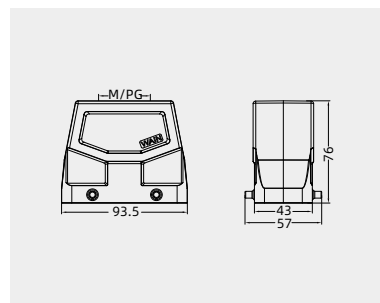

## Hoods, top entry, high construction



Thread	Designation	Order No.
M50	W16B-TEH-4B-M50	111 116 430 5006
PG36	W16B-TEH-4B-PG36	111 116 430 5013

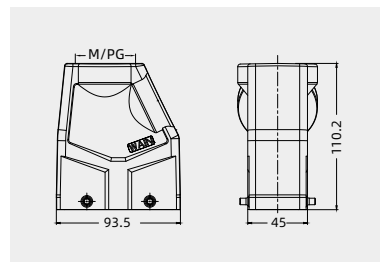

## 16B Metal hoods/housings

Degree of protection: IP67

## Bulkhead mounted housings



Thread	Designation	Order No.
---	W16B-BK-2L/SC	111 116 341 1002

Please refer to page 15-02 for choosing proper model of lock.

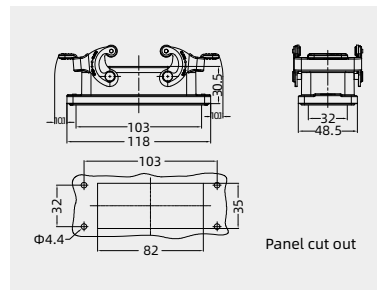

## Housings, cable to cable



Thread	Designation	Order No.
M25	W16B-CCT-2L/SC-M25	111 116 741 1001
M32	W16B-CCT-2L/SC-M32	111 116 741 1002
PG21	W16B-CCT-2L/SC-PG21	111 116 741 1003

Please refer to page 15-02 for choosing proper model of lock.

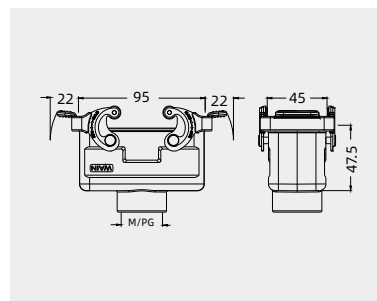

## Housings, cable to cable, high construction



Thread	Designation	Order No.
M25	W16B-CCTH-2L/SC-M25	111 116 741 5002
M32	W16B-CCTH-2L/SC-M32	111 116 741 5003
M40	W16B-CCTH-2L/SC-M40	111 116 741 5004
PG21	W16B-CCTH-2L/SC-PG21	111 116 741 5005
PG29	W16B-CCTH-2L/SC-PG29	111 116 741 5006
	with sleeve	
M32	W16B-CCTH-2L/SC-M32 WS	111 116 741 5013
PG21	W16B-CCTH-2L/SC-PG21 WS	111 116 741 5011
PG29	W16B-CCTH-2L/SC-PG29 WS	111 116 741 5012

Please refer to page 15-02 for choosing proper model of lock.

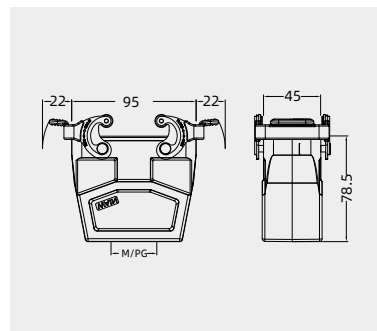

## 16B Metal hoods/housings

Degree of protection: IP67

## Hoods, side entry



Thread	Designation	Order No.
M25	W16B-SE-2L/SC-M25	111 116 541 1001
M32	W16B-SE-2L/SC-M32	111 116 541 1002
PG21	W16B-SE-2L/SC-PG21	111 116 541 1003

Please refer to page 15-02 for choosing proper model of lock.

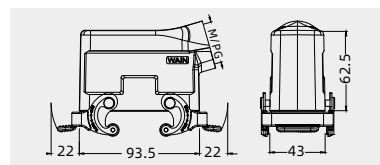

## Hoods, side entry, high construction



Thread	Designation	Order No.
M32	W16B-SEH-2L/SC-M32	111 116 541 5001
M40	W16B-SEH-2L/SC-M40	111 116 541 5002
PG21	W16B-SEH-2L/SC-PG21	111 116 541 5003
PG29	W16B-SEH-2L/SC-PG29	111 116 541 5004
	with sleeve	
M32	W16B-SEH-2L/SC-M32 WS	111 116 541 5005
PG21	W16B-SEH-2L/SC-PG21 WS	111 116 541 5011
PG29	W16B-SEH-2L/SC-PG29 WS	111 116 541 5006

Please refer to page 15-02 for choosing proper model of lock.

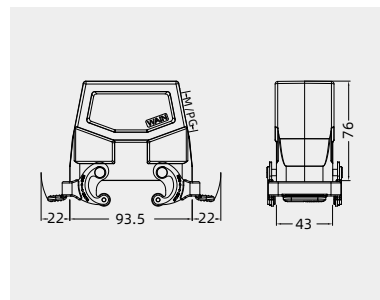

## Hoods, top entry



Thread	Designation	Order No.
M25	W16B-TE-2L/SC-M25	111 116 441 1001
M32	W16B-TE-2L/SC-M32	111 116 441 1002
PG21	W16B-TE-2L/SC-PG21	111 116 441 1003

Please refer to page 15-02 for choosing proper model of lock.

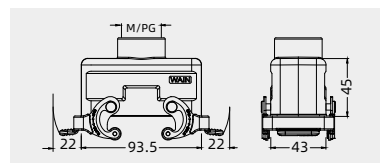

## Hoods, top entry, high construction



Thread	Designation	Order No.
M32	W16B-TEH-2L/SC-M32	111 116 441 5001
M40	W16B-TEH-2L/SC-M40	111 116 441 5002
PG21	W16B-TEH-2L/SC-PG21	111 116 441 5003
PG29	W16B-TEH-2L/SC-PG29	111 116 441 5004
	with sleeve	
M32	W16B-TEH-2L/SC-M32 WS	111 116 441 5009
PG21	W16B-TEH-2L/SC-PG21 WS	111 116 441 5011
PG29	W16B-TEH-2L/SC-PG29 WS	111 116 441 5012

Please refer to page 15-02 for choosing proper model of lock.

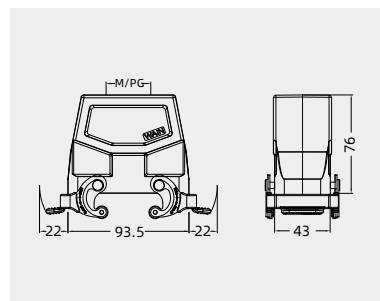

## Bulkhead mounted housings



Thread	Designation	Order No.
---	W16B-BK-4B	111 116 330 1001

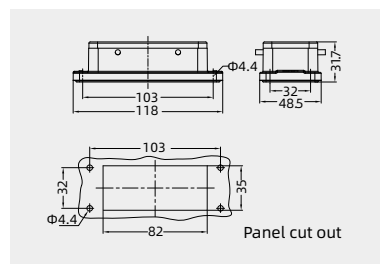

## 16B Metal hoods/housings

Degree of protection: IP67

### Hoods, side entry, high construction



Thread	Designation	Order No.
M25	W16B-SEH-1L/C-M25	111 116 550 5001
M32	W16B-SEH-1L/C-M32	111 116 550 5002
PG21	W16B-SEH-1L/C-PG21	111 116 550 5003
PG29	W16B-SEH-1L/C-PG29	111 116 550 5004
	with sleeve	
M32	W16B-SEH-1L/C-M32 <i>WS</i>	111 116 555 5004
PG21	W16B-SEH-1L/C-PG21 <i>WS</i>	111 116 555 5001
PG29	W16B-SEH-1L/C-PG29 <i>WS</i>	111 116 555 5002

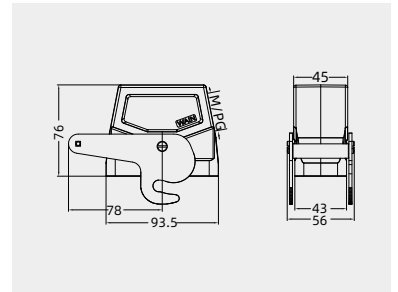

### Bulkhead mounted housings



Thread	Designation	Order No.
---	W16B-BK-2B/C	111 116 350 1001

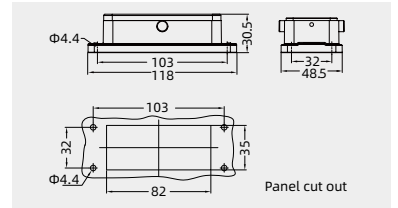

## 16B Metal hoods/housings

Degree of protection: IP67

## Hoods, side entry



Thread	Designation	Order No.
M25	W16B-MSE-4B-M25	112 116 530 1001
M32	W16B-MSE-4B-M32	112 116 530 1003
PG21	W16B-MSE-4B-PG21	112 116 530 1002

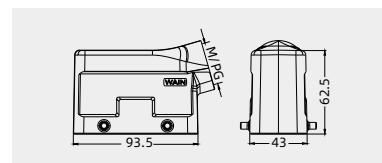

## Hoods, side entry, high construction



Thread	Designation	Order No.
M32	W16B-MSEH-4B-M32	112 116 530 5005
M40	W16B-MSEH-4B-M40	112 116 530 5006
PG21	W16B-MSEH-4B-PG21	112 116 530 5011
PG29	W16B-MSEH-4B-PG29	112 116 530 5007
	with sleeve	
M32	W16B-MSEH-4B-M32 <a href="#">WS</a>	112 116 530 5004
PG21	W16B-MSEH-4B-PG21 <a href="#">WS</a>	112 116 530 5001
PG29	W16B-MSEH-4B-PG29 <a href="#">WS</a>	112 116 530 5012

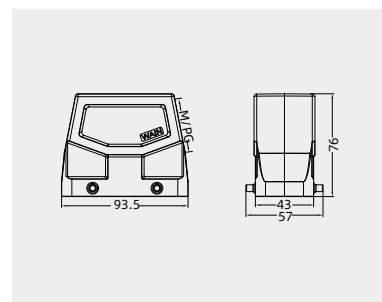

## Hoods, top entry



Thread	Designation	Order No.
M25	W16B-MTE-4B-M25	112 116 430 1001
M32	W16B-MTE-4B-M32	112 116 430 1003
PG21	W16B-MTE-4B-PG21	112 116 430 1002

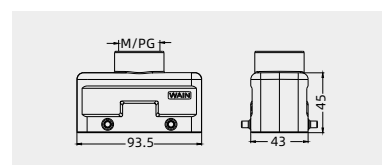

## Hoods, top entry, high construction



Thread	Designation	Order No.
M32	W16B-MTEH-4B-M32	112 116 430 5005
M40	W16B-MTEH-4B-M40	112 116 430 5001
PG21	W16B-MTEH-4B-PG21	112 116 430 5011
PG29	W16B-MTEH-4B-PG29	112 116 430 5006
	with sleeve	
M32	W16B-MTEH-4B-M32 <a href="#">WS</a>	112 116 430 5007
PG21	W16B-MTEH-4B-PG21 <a href="#">WS</a>	112 116 430 5008
PG29	W16B-MTEH-4B-PG29 <a href="#">WS</a>	112 116 430 5012

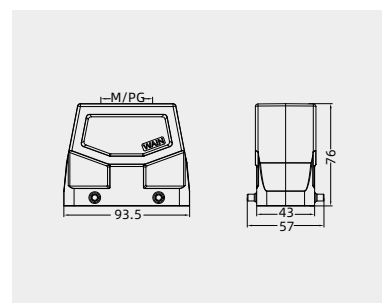

## Bulkhead mounted housings



Thread	Designation	Order No.
---	W16B-MBK-2L/SC	112 116 341 1001

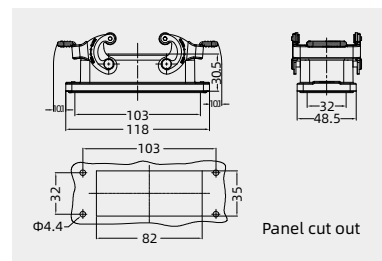

## 16B Metal hoods/housings -Suitable for harsh environment(anti-corrosion)

Degree of protection: IP67

### Housings, cable to cable



Thread	Designation	Order No.
M25	W16B-MCCT-2L/SC-M25	112 116 741 1002
M32	W16B-MCCT-2L/SC-M32	112 116 741 1003
PG21	W16B-MCCT-2L/SC-PG21	112 116 741 1001

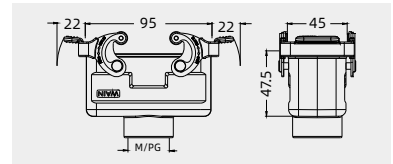

### Housings, cable to cable, high construction



Thread	Designation	Order No.
M32	W16B-MCCTH-2L/SC-M32	112 116 741 5004
M40	W16B-MCCTH-2L/SC-M40	112 116 741 5005
PG21	W16B-MCCTH-2L/SC-PG21	112 116 741 5011
PG29	W16B-MCCTH-2L/SC-PG29	112 116 741 5012
	with sleeve	
M32	W16B-MCCTH-2L/SC-M32 <b>WS</b>	112 116 741 5001
PG21	W16B-MCCTH-2L/SC-PG21 <b>WS</b>	112 116 741 5002
PG29	W16B-MCCTH-2L/SC-PG29 <b>WS</b>	112 116 741 5003

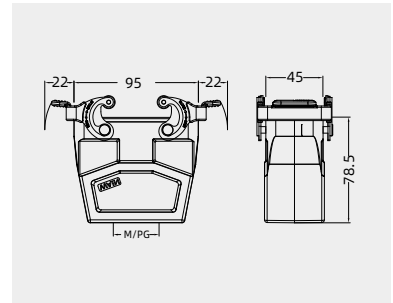

Degree of protection: IP67

### Hoods, side entry, high construction



Thread	Designation	Order No.
M32	W16B-MSEH-1L/C-M32	112 116 550 5005
PG21	W16B-MSEH-1L/C-PG21	112 116 550 5006
PG29	W16B-MSEH-1L/C-PG29	112 116 550 5007
	with sleeve	
M32	W16B-MSEH-1L/C-M32 <b>WS</b>	112 116 555 5004
PG21	W16B-MSEH-1L/C-PG21 <b>WS</b>	112 116 555 5011
PG29	W16B-MSEH-1L/C-PG29 <b>WS</b>	112 116 555 5012

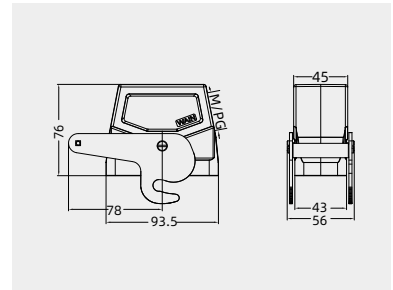

### Bulkhead mounted housings



Thread	Designation	Order No.
---	W16B-MBK-2B/C	112 116 350 1001

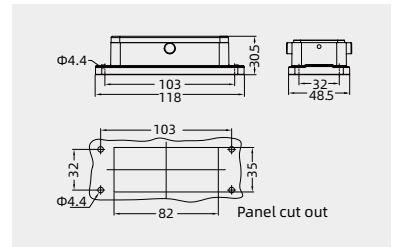



## 16B EMC Metal hoods/housings

Degree of protection: IP67

## Hoods, side entry



Thread	Designation	Order No.
M25	EMC.W16B-SE-4B-M25	111 216 530 1001
M32	EMC.W16B-SE-4B-M32	111 216 530 1002
PG21	EMC.W16B-SE-4B-PG21	111 216 530 1003

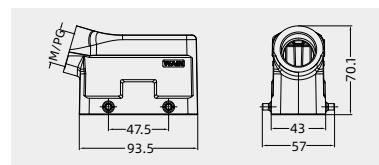

## Hoods, side entry, high construction



Thread	Designation	Order No.
---	EMC.W16B-BEH-4B	111 216 930 5004
M32	EMC.W16B-SEH-4B-M32	111 216 530 5008
M40	EMC.W16B-SEH-4B-M40	111 216 530 5009
PG21	EMC.W16B-SEH-4B-PG21	111 116 535 5014
PG29	EMC.W16B-SEH-4B-PG29	111 216 530 5010
M32	EMC.W16B-SEH-4B-M32 <a href="#">WS</a>	111 116 535 5002
PG21	EMC.W16B-SEH-4B-PG21 <a href="#">WS</a>	111 216 535 5506
PG29	EMC.W16B-SEH-4B-PG29 <a href="#">WS</a>	111 116 535 5003

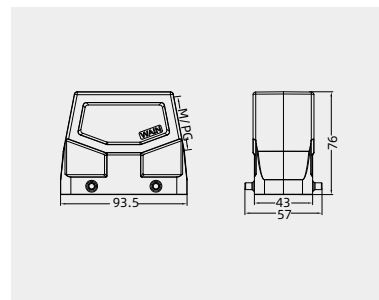

## Hoods, top entry



Thread	Designation	Order No.
M25	EMC.W16B-TE-4B-M25	111 216 430 1001
M32	EMC.W16B-TE-4B-M32	111 216 430 1002
PG21	EMC.W16B-TE-4B-PG21	111 216 430 1003

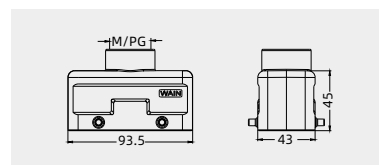

## Hoods, top entry, high construction



Thread	Designation	Order No.
---	EMC.W16B-BEH-4B	111 216 930 5004
M32	EMC.W16B-TEH-4B-M32	111 216 430 5007
M40	EMC.W16B-TEH-4B-M40	111 216 430 5008
PG21	EMC.W16B-TEH-4B-PG21	111 216 430 5012
PG29	EMC.W16B-TEH-4B-PG29	111 216 430 5009
M32	EMC.W16B-TEH-4B-M32 <a href="#">WS</a>	111 116 435 5004
PG21	EMC.W16B-TEH-4B-PG21 <a href="#">WS</a>	111 216 430 5010
PG29	EMC.W16B-TEH-4B-PG29 <a href="#">WS</a>	111 116 435 5002

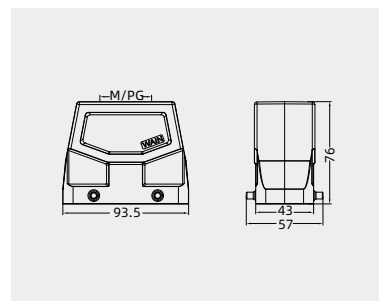

## Bulkhead mounted housings



Thread	Designation	Order No.
---	EMC1.W16B-BK-2L/ <a href="#">SC</a>	111 116 341 1001

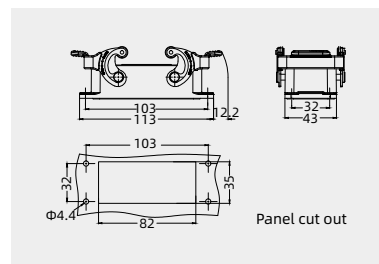

Please refer to page 15-02 for choosing proper model of lock.

16B Pressure tight hoods/housings

Degree of protection: IP68/IP69K

W version

Hoods, side entry, high construction



Thread	Designation	Order No.
M25	HP16B-SEH-2S-M25	115 016 520 5003
M32	HP16B-SEH-2S-M32	115 016 520 5104
M40	HP16B-SEH-2S-M40	115 016 520 5105
PG21	HP16B-SEH-2S-PG21	115 016 520 5111
PG29	HP16B-SEH-2S-PG29	115 016 520 5112

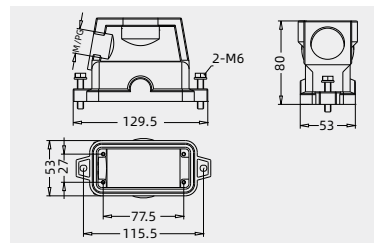

Hoods, top entry, high construction



Thread	Designation	Order No.
M25	HP16B-TEH-2S-M25	115 016 420 5103
M32	HP16B-TEH-2S-M32	115 016 420 5104
M40	HP16B-TEH-2S-M40	115 016 420 5105
M50	HP16B-TEH-2S-M50	115 016 420 5106
PG21	HP16B-TEH-2S-PG21	115 016 420 5111
PG29	HP16B-TEH-2S-PG29	115 016 420 5112

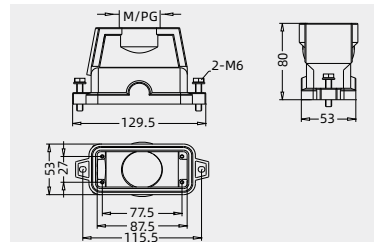

Surface mounted housings



Thread	Designation	Order No.
M25	HP16B-SFH-2H-M25	115 016 220 5003
M32	HP16B-SFH-2H-M32	115 016 220 5004
M40	HP16B-SFH-2H-M40	115 016 220 5005
PG21	HP16B-SFH-2H-PG21	115 016 220 5011
PG29	HP16B-SFH-2H-PG29	115 016 220 5012

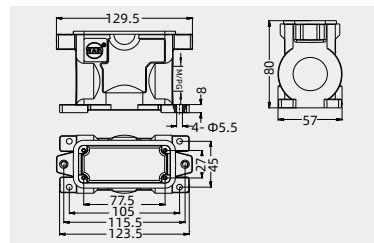

Bulkhead mounted housings



Thread	Designation	Order No.
---	HP16B-BK-2H	115 016 320 1001

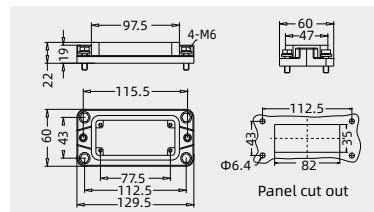

Bulkhead mounted housings



Thread	Designation	Order No.
---	HP16B-BK/S-2H	115 016 320 1004

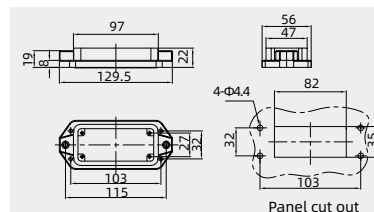

Protection covers, plastic



Describe for housings	Designation	Order No.
	HP16B-CV-2S/2	115 016 020 8002

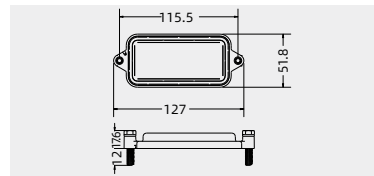

Protection covers, plastic



Describe for hoods	Designation	Order No.
	HP16B-CV-2H/1	115 016 020 8500

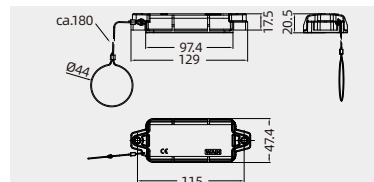

## 16B Pressure tight hoods/housings

Degree of protection: IP68/IP69K

H version

Hoods, side entry, high construction



Thread	Designation	Order No.
	Screw locking	
M25	HP16B/H-SEH-2S-M25	113 616 520 5003
M32	HP16B/H-SEH-2S-M32	113 616 520 5004
M40	HP16B/H-SEH-2S-M40	113 616 520 5005
M50	HP16B/H-SEH-2S-M50	113 616 520 5006
PG21	HP16B/H-SEH-2S-PG21	113 616 520 5011
PG29	HP16B/H-SEH-2S-PG29	113 616 520 5012
PG36	HP16B/H-SEH-2S-PG36	113 616 520 5013
	Toggle locking	
M25	HP16B/H-SEH-2T-M25	113 616 540 5003
M32	HP16B/H-SEH-2T-M32	113 616 540 5004
M40	HP16B/H-SEH-2T-M40	113 616 540 5005
M50	HP16B/H-SEH-2T-M50	113 616 540 5006
PG21	HP16B/H-SEH-2T-PG21	113 616 540 5011
PG29	HP16B/H-SEH-2T-PG29	113 616 540 5012
PG36	HP16B/H-SEH-2T-PG36	113 616 540 5013

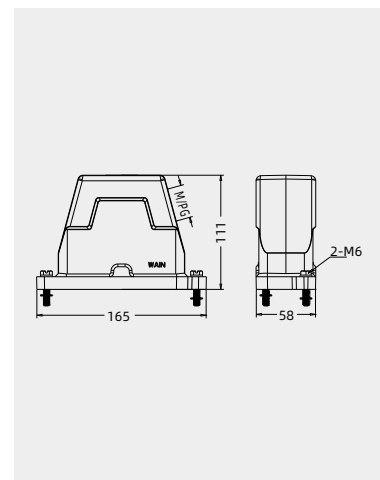

Hoods, top entry, high construction



Thread	Designation	Order No.
	Screw locking	
M25	HP16B/H-TEH-2S-M25	113 616 420 5003
2M25	HP16B/H-TEH-2S-2M25	113 616 420 5023
M32	HP16B/H-TEH-2S-M32	113 616 420 5004
M40	HP16B/H-TEH-2S-M40	113 616 420 5005
M50	HP16B/H-TEH-2S-M50	113 616 420 5006
PG21	HP16B/H-TEH-2S-PG21	113 616 420 5011
2PG21	HP16B/H-TEH-2S-2PG21	113 616 420 5031
PG29	HP16B/H-TEH-2S-PG29	113 616 420 5012
PG36	HP16B/H-TEH-2S-PG36	113 616 420 5013
	Toggle locking	
M25	HP16B/H-TEH-2T-M25	113 616 440 5003
2M25	HP16B/H-TEH-2T-2M25	113 616 440 5023
M32	HP16B/H-TEH-2T-M32	113 616 440 5004
M40	HP16B/H-TEH-2T-M40	113 616 440 5005
M50	HP16B/H-TEH-2T-M50	113 616 440 5006
PG21	HP16B/H-TEH-2T-PG21	113 616 440 5011
2PG21	HP16B/H-TEH-2T-2PG21	113 616 440 5031
PG29	HP16B/H-TEH-2T-PG29	113 616 440 5012
PG36	HP16B/H-TEH-2T-PG36	113 616 440 5013

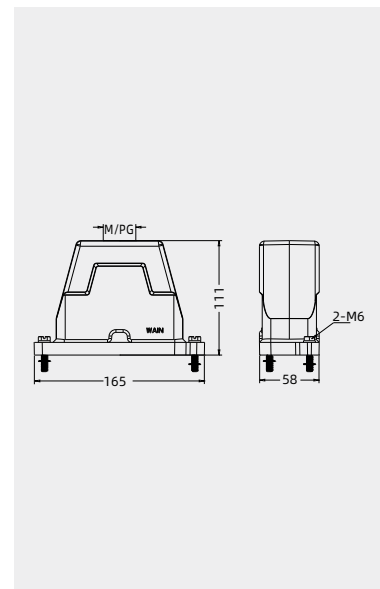

Surface mounted housings, high construction



Thread	Designation	Order No.
	Screw locking	
M25	HP16B/H-SFH-2H-M25	113 616 220 5003
M32	HP16B/H-SFH-2H-M32	113 616 220 5004
M40	HP16B/H-SFH-2H-M40	113 016 220 5002
M40	HP16B/H-SFH-2H-2M40	113 616 220 5025
PG21	HP16B/H-SFH-2H-PG21	113 616 220 5011
PG29	HP16B/H-SFH-2H-PG29	113 616 220 5012
PG36	HP16B/H-SFH-2H-PG36	113 616 220 5013
	Toggle locking	
M25	HP16B/H-SFH-2T-M25	113 616 240 5003
M32	HP16B/H-SFH-2T-M32	113 616 240 5004
M40	HP16B/H-SFH-2T-M40	113 616 240 5005
2M40	HP16B/H-SFH-2T-2M40	113 616 240 5025
PG21	HP16B/H-SFH-2T-PG21	113 616 240 5011
PG29	HP16B/H-SFH-2T-PG29	113 616 240 5012
PG36	HP16B/H-SFH-2T-PG36	113 616 240 5013

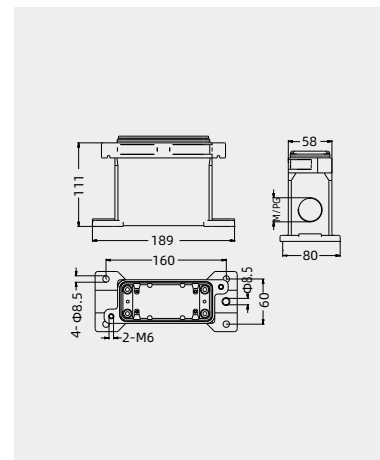

16B Pressure tight hoods/housings

Degree of protection: IP68/IP69K

H version

Bulkhead mounted housings



Thread	Designation	Order No.
---	Screw locking	
---	HP16B/H-BK-2H	113 616 320 1001
---	Toggle locking	
---	HP16B/H-BK-2T	113 616 340 1001
---	with metal cover	
---	Screw locking	
---	HP16B/H-BK-2H-MCV	113 616 360 1001
---	Toggle locking	
---	HP16B/H-BK-2T-MCV	113 616 370 1001

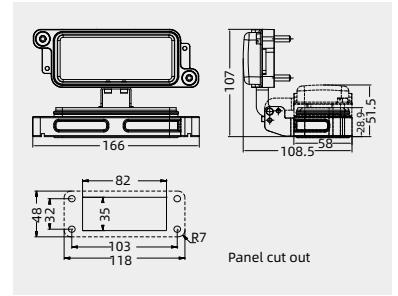

Protection covers, for housings



Connect way	Designation	Order No.
---	Screw locking	
⊙	HP16B/H-MCV-2S	113 616 020 8101
---	Toggle locking	
⊙	HP16B/H-MCV-2T	113 616 040 8103

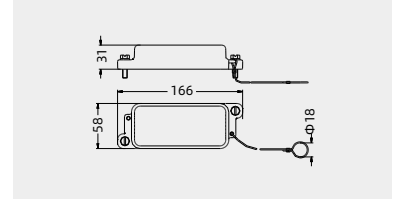

Protection covers, for hoods



Connect way	Designation	Order No.
---	Screw locking	
⊙	HP16B/H-MCV-2H/1	113 616 020 8111
---	Toggle locking	
⊙	HP16B/H-MCV-2T/1	113 616 040 8101

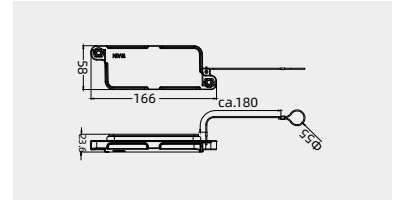

Protection covers, for housings(IP5X)



Connect way	Designation	Order No.
---	HP16B/H-CV/C	113 016 900 8001

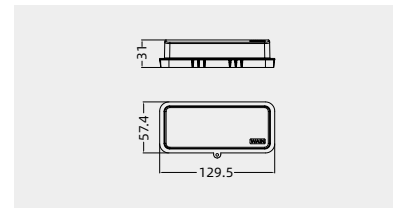

Hoods, side entry, high construction



Thread	Designation	Order No.
M40	HP16B/H-SEH-2S-1L/C-M40	113 616 520 5507

Other outlet hole threads available

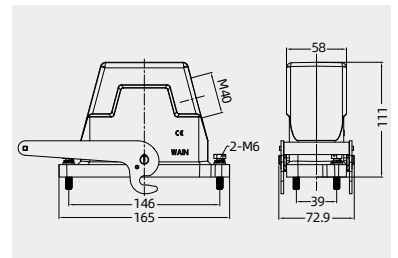

Bulkhead mounted housings



Thread	Designation	Order No.
---	HP16B/H-BK-2H-2B/C	113 616 320 1500

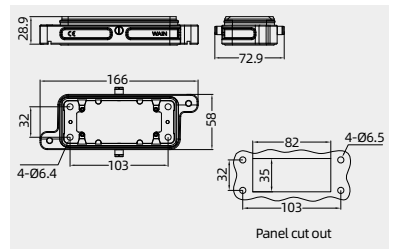

# 16B Pressure tight hoods/housings

Degree of protection: IP68/IP69K

The following hoods/housings comply with the standards for rail transport industry in China.

## H version

### Hoods, side entry, high construction



Thread	Designation	Order No.
M25	HP16B/H-SEH-4S-M25	113 616 530 5003
M32	HP16B/H-SEH-4S-M32	113 616 530 5004
M40	HP16B/H-SEH-4S-M40	113 616 530 5005
PG21	HP16B/H-SEH-4S-PG21	113 616 530 5011
PG29	HP16B/H-SEH-4S-PG29	113 616 530 5012

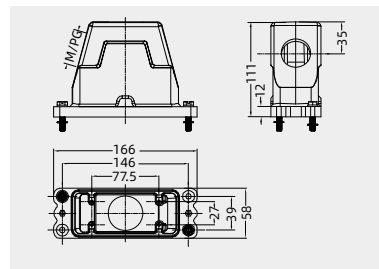

### Hoods, top entry, high construction



Thread	Designation	Order No.
M25	HP16B/H-TEH-4S-M25	113 616 430 5003
M32	HP16B/H-TEH-4S-M32	113 616 430 5004
M40	HP16B/H-TEH-4S-M40	113 616 430 5005
M50	HP16B/H-TEH-4S-M50	113 616 430 5006
PG21	HP16B/H-TEH-4S-PG21	113 616 430 5011
PG29	HP16B/H-TEH-4S-PG29	113 616 430 5012
PG36	HP16B/H-TEH-4S-PG36	113 616 430 5013

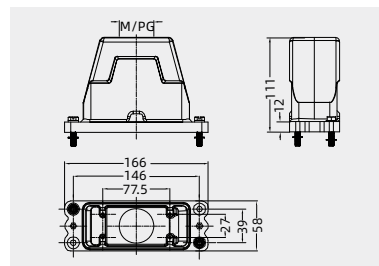

### Bulkhead mounted housings



Thread	Designation	Order No.
---	HP16B/H-BK-4H	113 616 330 1001

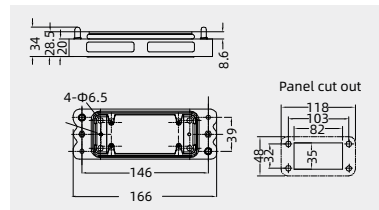

## 16B Pressure tight hoods/housings

Degree of protection: IP68/IP69K

## Hoods, side entry, high construction



Thread	Designation	Order No.
M32	HC16B-SEH-2S-M32	114 016 520 5004
M40	HC16B-SEH-2S-M40	114 016 520 5005
PG21	HC16B-SEH-2S-PG21	114 016 520 5011
PG29	HC16B-SEH-2S-PG29	114 016 520 5012

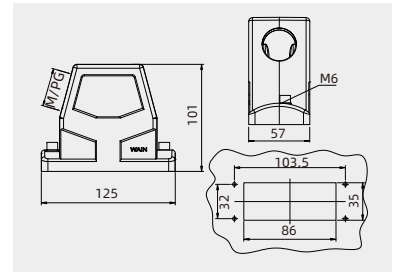

## Hoods, top entry, high construction



Thread	Designation	Order No.
M32	HC16B-TEH-2S-M32	114 016 420 5004
M40	HC16B-TEH-2S-M40	114 016 420 5005
PG21	HC16B-TEH-2S-PG21	114 016 420 5011
PG29	HC16B-TEH-2S-PG29	114 016 420 5012

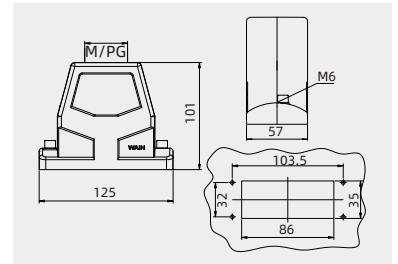

## Mounting flange



Applications	Designation	Order No.
for integral type hoods	APT-C	114 000 000 1001

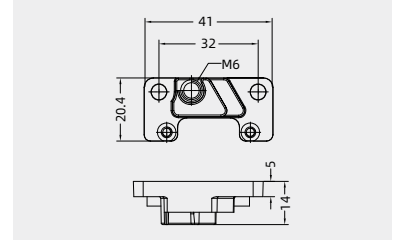

## Protection covers, plastic

Degree of protection: IP65



Thread	Designation	Order No.
---	HC16B-CV-2S/2	130 016 020 8001

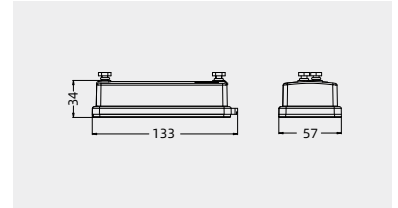

# 16B Pressure tight hoods/housings

Degree of protection: IP68/IP69K

## Hoods, top entry, high construction



Thread	Designation	Order No.
M32	EMC.W16B-TEH-4S-M32	111 116 430 5010
M40	EMC.W16B-TEH-4S-M40	111 116 430 5011
PG21	EMC.W16B-TEH-4S-PG21	111 116 430 5012
PG29	EMC.W16B-TEH-4S-PG29	111 216 430 5002

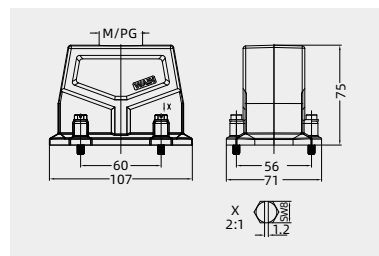

## Hoods, top entry, high construction



Thread	Designation	Order No.
M32	EMC.W16B-SEH-4S-M32	111 216 530 5002
M40	EMC.W16B-SEH-4S-M40	111 216 530 5003
PG21	EMC.W16B-SEH-4S-PG21	111 216 530 5004
PG29	EMC.W16B-SEH-4S-PG29	111 216 530 5005

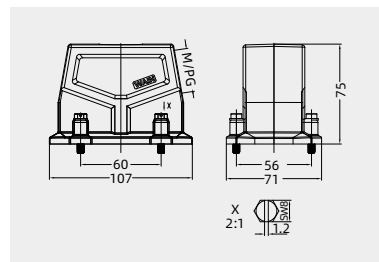

## Bulkhead mounted housings



Thread	Designation	Order No.
---	EMC.W16B-BK-4H	111 216 330 1001

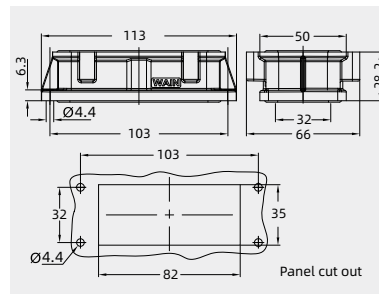

## Protection covers, plastic



Degree of protection: IP20



Applications	Designation	Order No.
cover for hoods	H16B-CV/2C-4H	111 116 000 1502

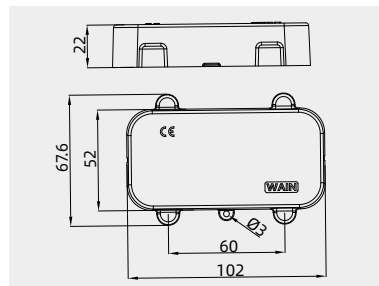

Degree of protection: IP20



Applications	Designation	Order No.
cover for housings	H16B-CV/1C-4S	111 116 000 1503

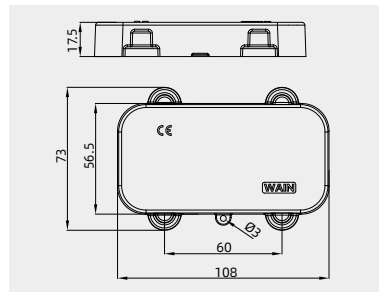

# 16B Metal hoods/housings - for high voltage inserts(HVE Series)

Degree of protection: IP65

## Hoods, side entry



Thread	Designation	Order No.
M25	HV16B-SE-2B-M25	124 016 515 1003
PG21	HV16B-SE-2B-PG21	124 016 515 1011

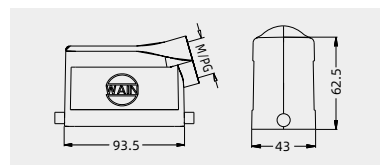

## Hoods, side entry, high construction



Thread	Designation	Order No.
M32	WV16B-SEH-2B-M32	124 116 510 5001
M40	WV16B-SEH-2B-M40	124 116 510 5002
PG21	WV16B-SEH-2B-PG21	124 116 510 5003
PG29	WV16B-SEH-2B-PG29	124 116 510 5004
	with sleeve	
M32	WV16B-SEH-2B-M32 WS	124 116 515 5004
PG21	WV16B-SEH-2B-PG21 WS	124 116 515 5011
PG29	WV16B-SEH-2B-PG29 WS	124 116 515 5012

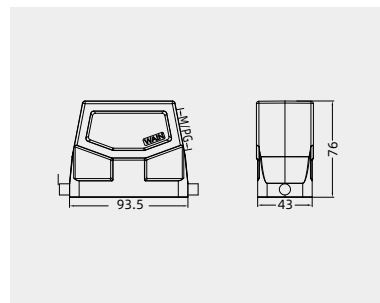

## Hoods, top entry



Thread	Designation	Order No.
M25	HV16B-TE-2B-M25	124 016 415 1003
M32	HV16B-TE-2B-M32	124 016 415 1004
PG21	HV16B-TE-2B-PG21	124 016 415 1011

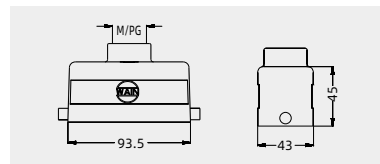

## Hoods, top entry, high construction



Thread	Designation	Order No.
M32	WV16B-TEH-2B-M32	124 116 410 5001
M40	WV16B-TEH-2B-M40	124 116 410 5002
PG21	WV16B-TEH-2B-PG21	124 116 410 5003
PG29	WV16B-TEH-2B-PG29	124 116 410 5004
	with sleeve	
M32	WV16B-TEH-2B-M32 WS	124 116 415 5004
PG21	WV16B-TEH-2B-PG21 WS	124 116 415 5011
PG29	WV16B-TEH-2B-PG29 WS	124 116 415 5012

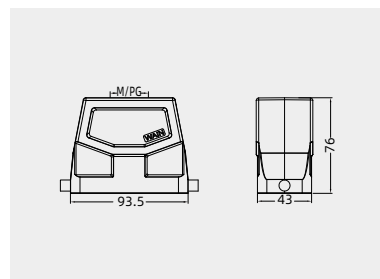

## Housings, cable to cable



Thread	Designation	Order No.
M25	HV16B-CCT-1L/SC-M25	124 016 721 1003
PG21	HV16B-CCT-1L/SC-PG21	124 016 721 1011

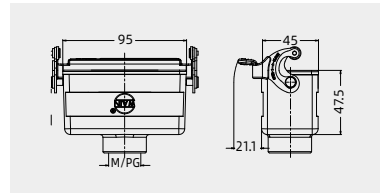

Please refer to page 15-02 for choosing proper model of lock.

## Housings, cable to cable, high construction



Thread	Designation	Order No.
M32	WV16B-CCTH-1L/SC-M32	124 116 721 5001
M40	WV16B-CCTH-1L/SC-M40	124 116 721 5002
PG21	WV16B-CCTH-1L/SC-PG21	124 116 721 5003
PG29	WV16B-CCTH-1L/SC-PG29	124 116 721 5004
	with sleeve	
M32	WV16B-CCTH-1L/SC-M32 WS	124 116 721 5005
PG21	WV16B-CCTH-1L/SC-PG21 WS	124 116 721 5011
PG29	WV16B-CCTH-1L/SC-PG29 WS	124 116 721 5012

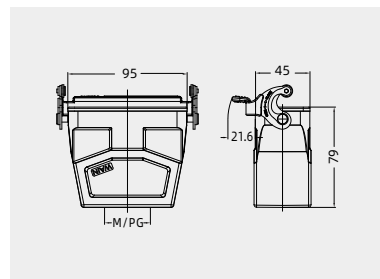

Please refer to page 15-02 for choosing proper model of lock.



16B Metal hoods/housings  
- for high voltage inserts(HVE Series)

Degree of protection: IP65

Bulkhead mounted housings



Thread	Designation	Order No.
---	HV16B-BK-1L/SC	124 016 321 1001
with plastic cover		
---	HV16B-BK-1L/SC-CV	124 016 361 1001
with metal cover		
---	HV16B-BK-1L/SC-MCV	124 016 361 1101

Please refer to page 15-02 for choosing proper model of lock.

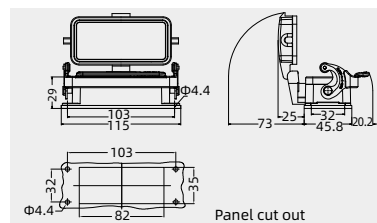

Surface mounted housings



Thread	Designation	Order No.
M25	HV16B-SF-1L/SC-M25	124 016 221 1003
2M25	HV16B-SF-1L/SC-2M25	124 016 221 1023
PG21	HV16B-SF-1L/SC-PG21	124 016 221 1011
2PG21	HV16B-SF-1L/SC-2PG21	124 016 221 1031

with plastic cover

M25	HV16B-SF-1L/SC-CV-M25	124 016 261 1003
2M25	HV16B-SF-1L/SC-CV-2M25	124 016 261 1023
PG21	HV16B-SF-1L/SC-CV-PG21	124 016 261 1011
2PG21	HV16B-SF-1L/SC-CV-2PG21	124 016 261 1031

with metal cover

M25	HV16B-SF-1L/SC-MCV-M25	124 016 261 1103
2M25	HV16B-SF-1L/SC-MCV-2M25	124 016 261 1123
PG21	HV16B-SF-1L/SC-MCV-PG21	124 016 261 1111
2PG21	HV16B-SF-1L/SC-MCV-2PG21	124 016 261 1131

Please refer to page 15-02 for choosing proper model of lock.

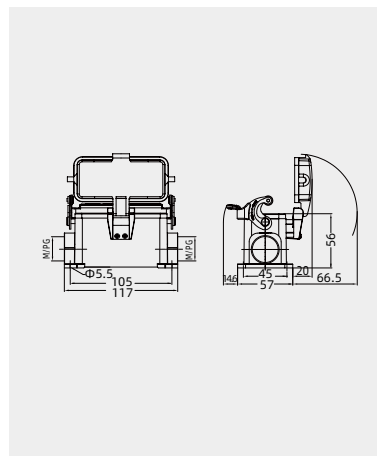

Surface mounted housings, high construction



Thread	Designation	Order No.
M32	HV16B-SFH-1L/SC-M32	124 016 221 5004
2M32	HV16B-SFH-1L/SC-2M32	124 016 221 5024
PG21	HV16B-SFH-1L/SC-PG21	124 016 221 5011
2PG21	HV16B-SFH-1L/SC-2PG21	124 016 221 5031
PG29	HV16B-SFH-1L/SC-PG29	124 016 221 5012
2PG29	HV16B-SFH-1L/SC-2PG29	124 016 221 5032

with plastic cover

M32	HV16B-SFH-1L/SC-CV-M32	124 016 261 5004
2M32	HV16B-SFH-1L/SC-CV-2M32	124 016 261 5024
PG21	HV16B-SFH-1L/SC-CV-PG21	124 016 261 5011
2PG21	HV16B-SFH-1L/SC-CV-2PG21	124 016 261 5031
PG29	HV16B-SFH-1L/SC-CV-PG29	124 016 261 5012
2PG29	HV16B-SFH-1L/SC-CV-2PG29	124 016 261 5032

with metal cover

M32	HV16B-SFH-1L/SC-MCV-M32	124 016 261 5104
2M32	HV16B-SFH-1L/SC-MCV-2M32	124 016 261 5124
PG21	HV16B-SFH-1L/SC-MCV-PG21	124 016 261 5111
2PG21	HV16B-SFH-1L/SC-MCV-2PG21	124 016 261 5131
PG29	HV16B-SFH-1L/SC-MCV-PG29	124 016 261 5112
2PG29	HV16B-SFH-1L/SC-MCV-2PG29	124 016 261 5132

Please refer to page 15-02 for choosing proper model of lock.

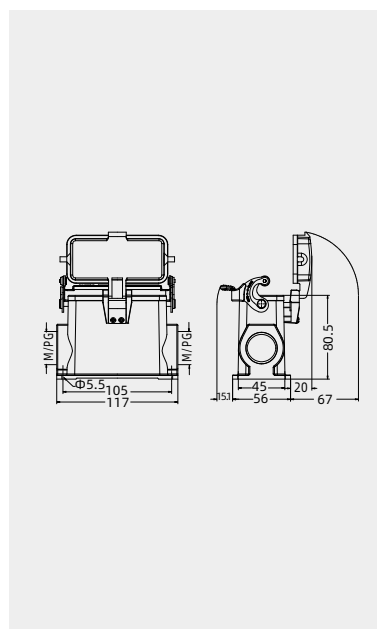

# 16B Metal hoods/housings - for high voltage inserts(HVE Series)

Degree of protection: IP65

## Hoods, side entry



Thread	Designation	Order No.
M25	HV16B-SE-4B-M25	124 016 530 1003
M32	HV16B-SE-4B-M32	124 016 530 1004
PG21	HV16B-SE-4B-PG21	124 016 530 1011

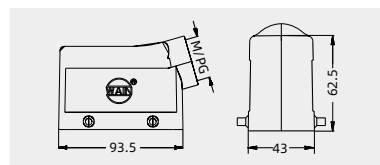

## Hoods, side entry, high construction



Thread	Designation	Order No.
M32	WV16B-SEH-4B-M32	124 116 530 5001
M40	WV16B-SEH-4B-M40	124 116 530 5002
PG21	WV16B-SEH-4B-PG21	124 116 530 5003
PG29	WV16B-SEH-4B-PG29 with sleeve	124 116 530 5004
M32	WV16B-SEH-4B-M32 <a href="#">WS</a>	124 116 530 5007
PG21	WV16B-SEH-4B-PG21 <a href="#">WS</a>	124 116 530 5011
PG29	WV16B-SEH-4B-PG29 <a href="#">WS</a>	124 116 530 5012

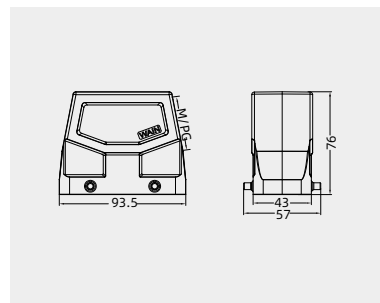

## Hoods, top entry



Thread	Designation	Order No.
M25	HV16B-TE-4B-M25	124 016 430 1003
PG21	HV16B-TE-4B-PG21	124 016 430 1011

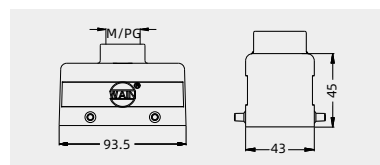

## Hoods, top entry, high construction



Thread	Designation	Order No.
M32	WV16B-TEH-4B-M32	124 116 430 5001
M40	WV16B-TEH-4B-M40	124 116 430 5002
PG21	WV16B-TEH-4B-PG21	124 116 430 5003
PG29	WV16B-TEH-4B-PG29 with sleeve	124 116 430 5004
M32	WV16B-TEH-4B-M32 <a href="#">WS</a>	124 116 430 5007
PG21	WV16B-TEH-4B-PG21 <a href="#">WS</a>	124 116 430 5011
PG29	WV16B-TEH-4B-PG29 <a href="#">WS</a>	124 116 430 5012

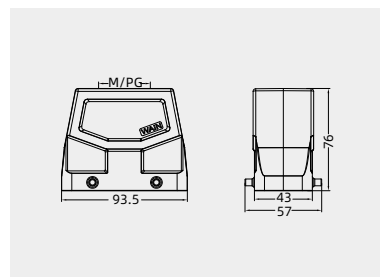

## 16B Metal hoods/housings - for high voltage inserts(HVE Series)

Degree of protection: IP65

### Bulkhead mounted housings



Thread	Designation	Order No.
---	HV16B-BK-2L/SC	124 016 341 1001

Please refer to page 15-02 for choosing proper model of lock.

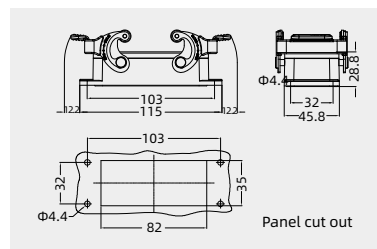

### Surface mounted housings



Thread	Designation	Order No.
M25	HV16B-SF-2L/SC-M25	124 016 241 1003
2M25	HV16B-SF-2L/SC-2M25	124 016 241 1023
PG21	HV16B-SF-2L/SC-PG21	124 016 241 1011
2PG21	HV16B-SF-2L/SC-2PG21	124 016 241 1031

Please refer to page 15-02 for choosing proper model of lock.

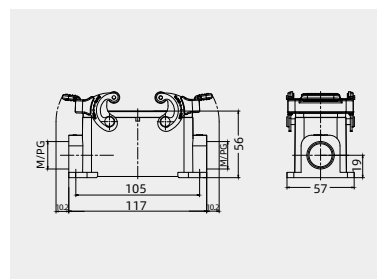

### Surface mounted housings, high construction



Thread	Designation	Order No.
M32	HV16B-SFH-2L/SC-M32	124 016 241 5004
2M32	HV16B-SFH-2L/SC-2M32	124 016 241 5024
PG21	HV16B-SFH-2L/SC-PG21	124 016 241 5011
2PG21	HV16B-SFH-2L/SC-2PG21	124 016 241 5031
PG29	HV16B-SFH-2L/SC-PG29	124 016 241 5012
2PG29	HV16B-SFH-2L/SC-2PG29	124 016 241 5032

Please refer to page 15-02 for choosing proper model of lock.

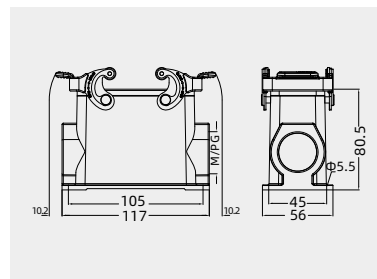

### Surface mounted housings, high construction



Thread	Designation	Order No.
M25	HV16B-CCT-2L/SC-M25	124 016 741 1003
PG21	HV16B-CCT-2L/SC-PG21	124 016 741 1011

Please refer to page 15-02 for choosing proper model of lock.

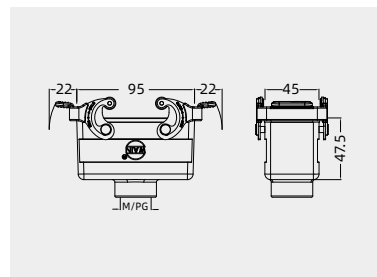

## 16B Metal hoods/housings - for high voltage inserts(HVE Series)

Degree of protection: IP65

Housings, cable to cable, high construction



Thread	Designation	Order No.
M32	WV16B-CCTH-2L/SC-M32	124 116 741 5001
M40	WV16B-CCTH-2L/SC-M40	124 116 741 5002
PG21	WV16B-CCTH-2L/SC-PG21	124 116 741 5003
PG29	WV16B-CCTH-2L/SC-PG29	124 116 741 5004
	with sleeve	
M32	WV16B-CCTH-2L/SC-M32 WS	124 116 741 5005
PG21	WV16B-CCTH-2L/SC-PG21 WS	124 116 741 5011
PG29	WV16B-CCTH-2L/SC-PG29 WS	124 116 741 5012

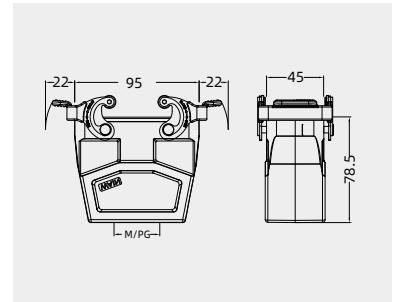

Protection covers, plastic



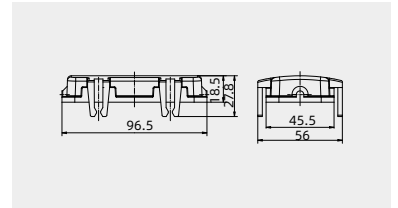

Connect way	Applications	Designation	Order No.
---	for hoods	H16B-CV-4C	111 016 090 8009



Protection covers, plastic



Connect way	Applications	Designation	Order No.
	for Housings, cable to cable	H16B-CV-4B/1	111 016 030 8001
	for Housings, bulkhead mounting / surface mounting	H16B-CV-4B/2	111 016 030 8002

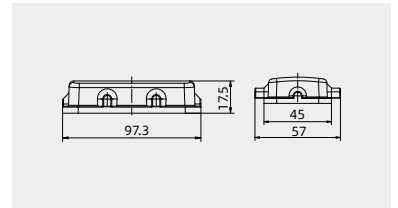

## 16B Metal hoods/housings - for high voltage inserts(HVE Series)

Degree of protection: IP65

### Hoods, side entry



Thread	Designation	Order No.
M25	HV16B-SE-2L/SC-M25	124 016 541 1003
M32	HV16B-SE-2L/SC-M32	124 016 541 1004
PG21	HV16B-SE-2L/SC-PG21	124 016 541 1011

Please refer to page 15-02 for choosing proper model of lock.

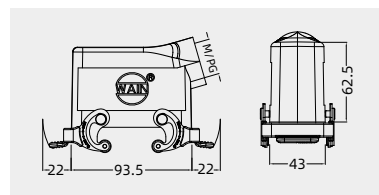

### Hoods, side entry, high construction



Thread	Designation	Order No.
M32	WV16B-SEH-2L/SC-M32	124 116 541 5001
M40	WV16B-SEH-2L/SC-M40	124 116 541 5002
PG21	WV16B-SEH-2L/SC-PG21	124 116 541 5003
PG29	WV16B-SEH-2L/SC-PG29	124 116 541 5004
	with sleeve	
M32	WV16B-SEH-2L/SC-M32 WS	124 116 541 5006
PG21	WV16B-SEH-2L/SC-PG21 WS	124 116 541 5011
PG29	WV16B-SEH-2L/SC-PG29 WS	124 116 541 5012

Please refer to page 15-02 for choosing proper model of lock.

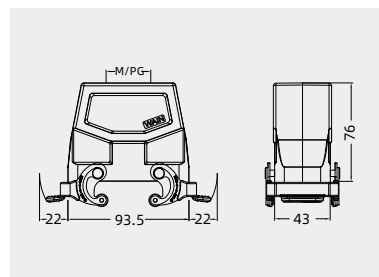

### Hoods, top entry



Thread	Designation	Order No.
M25	HV16B-TE-2L/SC-M25	124 016 441 1003
PG21	HV16B-TE-2L/SC-PG21	124 016 441 1011

Please refer to page 15-02 for choosing proper model of lock.

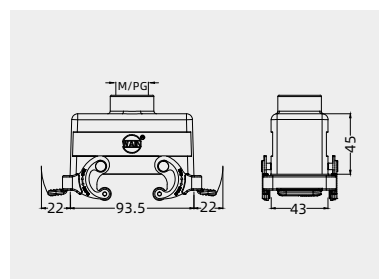

### Hoods, top entry, high construction



Thread	Designation	Order No.
M32	WV16B-TEH-2L/SC-M32	124 116 441 5001
M40	WV16B-TEH-2L/SC-M40	124 116 441 5002
PG21	WV16B-TEH-2L/SC-PG21	124 116 441 5003
PG29	WV16B-TEH-2L/SC-PG29	124 116 441 5004
	with sleeve	
M32	WV16B-TEH-2L/SC-M32 WS	124 116 441 5005
PG21	WV16B-TEH-2L/SC-PG21 WS	124 116 441 5011
PG29	WV16B-TEH-2L/SC-PG29 WS	124 116 441 5012

Please refer to page 15-02 for choosing proper model of lock.

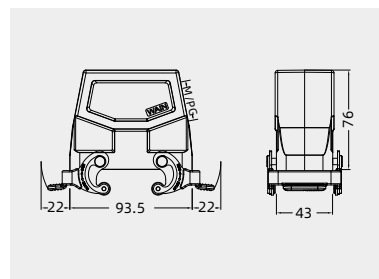

### Bulkhead mounted housings



Thread	Designation	Order No.
---	HV16B-BK-4B	124 016 330 1001
	with plastic cover	
---	HV16B-BK-4B-CV	124 016 370 1001
	with metal cover	
---	HV16B-BK-4B-MCV	124 016 370 1101

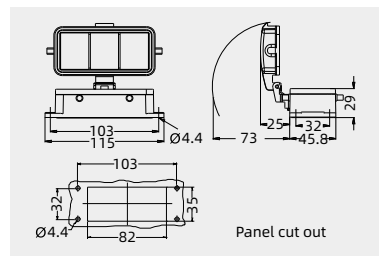

# HV16B Metal hoods/housings - for high voltage inserts(HVE Series)

Degree of protection: IP65

## Surface mounted housings



Thread	Designation	Order No.
M25	HV16B-SF-4B-M25	124 016 230 1003
2M25	HV16B-SF-4B-2M25	124 016 230 1023
PG21	HV16B-SF-4B-PG21	124 016 230 1011
2PG21	HV16B-SF-4B-2PG21	124 016 230 1031
with plastic cover		
M25	HV16B-SF-4B-CV-M25	124 016 270 1003
2M25	HV16B-SF-4B-CV-2M25	124 016 270 1023
PG21	HV16B-SF-4B-CV-PG21	124 016 270 1011
2PG21	HV16B-SF-4B-CV-2PG21	124 016 270 1031
with metal cover		
M25	HV16B-SF-4B-MCV-M25	124 016 270 1103
2M25	HV16B-SF-4B-MCV-2M25	124 016 270 1123
PG21	HV16B-SF-4B-MCV-PG21	124 016 270 1111
2PG21	HV16B-SF-4B-MCV-2PG21	124 016 270 1131

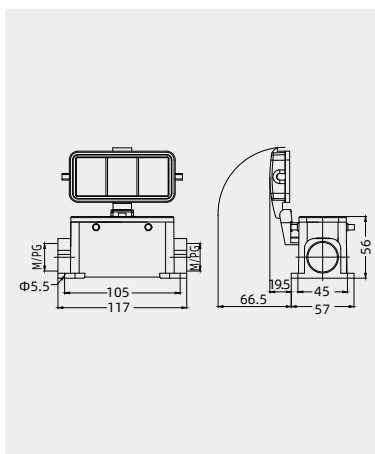

H

## Surface mounted housings, high construction



Thread	Designation	Order No.
M32	HV16B-SFH-4B-M32	124 016 230 5004
2M32	HV16B-SFH-4B-2M32	124 016 230 5024
PG21	HV16B-SFH-4B-PG21	124 016 230 5011
2PG21	HV16B-SFH-4B-2PG21	124 016 230 5031
PG29	HV16B-SFH-4B-PG29	124 016 230 5012
2PG29	HV16B-SFH-4B-2PG29	124 016 230 5032
with plastic cover		
M32	HV16B-SFH-4B-CV-M32	124 016 270 5004
2M32	HV16B-SFH-4B-CV-2M32	124 016 270 5024
PG21	HV16B-SFH-4B-CV-PG21	124 016 270 5011
2PG21	HV16B-SFH-4B-CV-2PG21	124 016 270 5031
PG29	HV16B-SFH-4B-CV-PG29	124 016 270 5012
2PG29	HV16B-SFH-4B-CV-2PG29	124 016 270 5032
with metal cover		
M32	HV16B-SFH-4B-MCV-M32	124 016 270 5104
2M32	HV16B-SFH-4B-MCV-2M32	124 016 270 5124
PG21	HV16B-SFH-4B-MCV-PG21	124 016 270 5111
2PG21	HV16B-SFH-4B-MCV-2PG21	124 016 270 5131
PG29	HV16B-SFH-4B-MCV-PG29	124 016 270 5112
2PG29	HV16B-SFH-4B-MCV-2PG29	124 016 270 5132

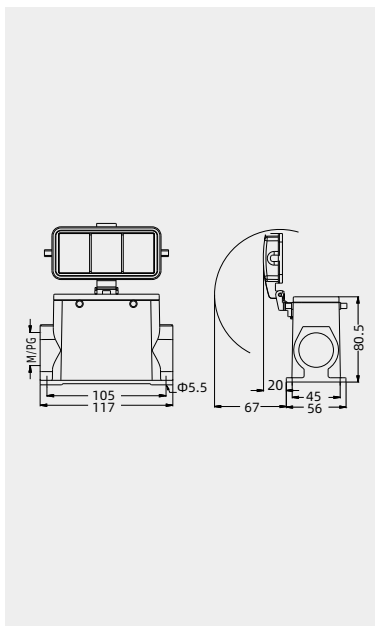

## Protection covers, metal



Connect way	Applications	Designation	Order No.
	for hoods	H16B-MCV-4B/1S	111 016 030 8103
	for housings, without sealing	H16B-MCV-4B/2	111 016 030 8102

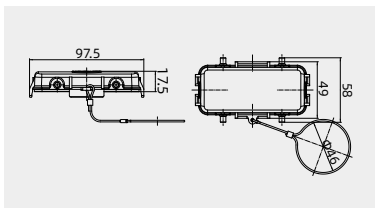

## Protection covers, metal



Connect way	Applications	Designation	Order No.
	for hoods	H16B-MCV-2L/SC.1S	111 016 041 8101
	or housings	H16B-MCV-2L/SC.2	111 016 041 8102

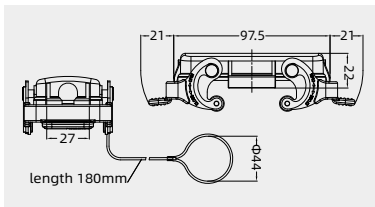

Please refer to page 15-02 for choosing proper model of lock.

HV16B Metal hoods/housings  
- for high voltage inserts(HVE Series)

Degree of protection: IP65

Hoods, side entry, high construction



Thread	Designation	Order No.
M32	WV16B-SEH-1L/C-M32	124 116 550 5001
PG21	WV16B-SEH-1L/C-PG21	124 116 550 5002
PG29	WV16B-SEH-1L/C-PG29	124 116 550 5003
	with sleeve	
M32	WV16B-SEH-1L/C-M32 WS	124 116 555 5004
PG21	WV16B-SEH-1L/C-PG21 WS	124 116 555 5011
PG29	WV16B-SEH-1L/C-PG29 WS	124 116 555 5012

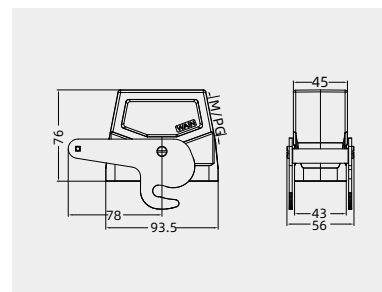

Bulkhead mounted housings



Thread	Designation	Order No.
---	HV16B-BK-2B/C	124 016 355 1001

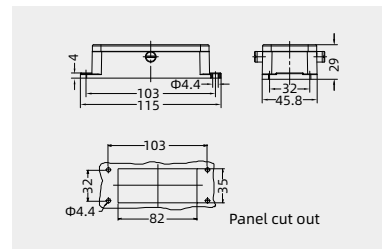

## HV16B Metal hoods/housings - for high voltage inserts(HVE Series)

Degree of protection: IP67

### Hoods, side entry



Thread	Designation	Order No.
M25	WV16B-SE-2B-M25	124 116 510 1001
PG21	WV16B-SE-2B-PG21	124 116 510 1002

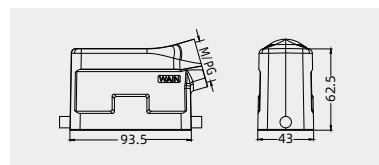

### Hoods, side entry, high construction



Thread	Designation	Order No.
M32	WV16B-SEH-2B-M32	124 116 510 5001
M40	WV16B-SEH-2B-M40	124 116 510 5002
PG21	WV16B-SEH-2B-PG21	124 116 510 5003
PG29	WV16B-SEH-2B-PG29 with sleeve	124 116 510 5004
M32	WV16B-SEH-2B-M32 <a href="#">WS</a>	124 116 515 5004
PG21	WV16B-SEH-2B-PG21 <a href="#">WS</a>	124 116 515 5011
PG29	WV16B-SEH-2B-PG29 <a href="#">WS</a>	124 116 515 5012

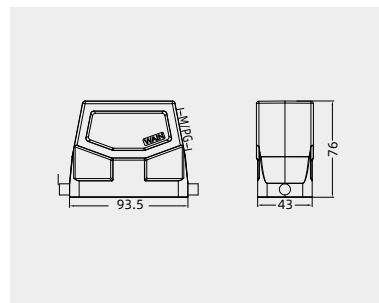

### Hoods, top entry



Thread	Designation	Order No.
M25	WV16B-TE-2B-M25	124 116 410 1001
M32	WV16B-TE-2B-M32	124 116 410 1002
PG21	WV16B-TE-2B-PG21	124 116 410 1003

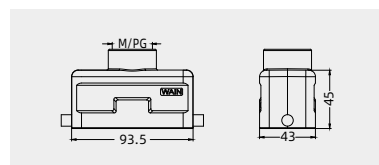

### Hoods, top entry, high construction



Thread	Designation	Order No.
M32	WV16B-TEH-2B-M32	124 116 410 5001
M40	WV16B-TEH-2B-M40	124 116 410 5002
PG21	WV16B-TEH-2B-PG21	124 116 410 5003
PG29	WV16B-TEH-2B-PG29 with sleeve	124 116 410 5004
M32	WV16B-TEH-2B-M32 <a href="#">WS</a>	124 116 415 5004
PG21	WV16B-TEH-2B-PG21 <a href="#">WS</a>	124 116 415 5011
PG29	WV16B-TEH-2B-PG29 <a href="#">WS</a>	124 116 415 5012

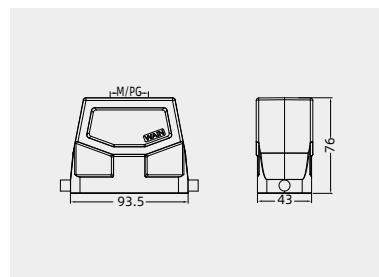



## HV16B Metal hoods/housings - for high voltage inserts(HVE Series)

Degree of protection: IP65

### Housings, cable to cable



Thread	Designation	Order No.
M25	WV16B-CCT-1L/SC-M25	124 116 721 1001
PG21	WV16B-CCT-1L/SC-PG21	124 116 721 1002

Please refer to page 15-02 for choosing proper model of lock.

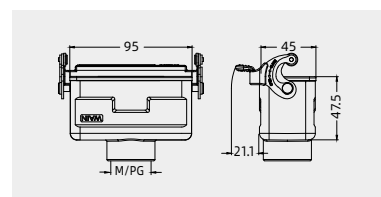

### Housings, cable to cable, high construction



Thread	Designation	Order No.
M32	WV16B-CCTH-1L/SC-M32	124 116 721 5001
M40	WV16B-CCTH-1L/SC-M40	124 116 721 5002
PG21	WV16B-CCTH-1L/SC-PG21	124 116 721 5003
PG29	WV16B-CCTH-1L/SC-PG29	124 116 721 5004
	with sleeve	
M32	WV16B-CCTH-1L/SC-M32 WS	124 116 721 5005
PG21	WV16B-CCTH-1L/SC-PG21 WS	124 116 721 5011
PG29	WV16B-CCTH-1L/SC-PG29 WS	124 116 721 5012

Please refer to page 15-02 for choosing proper model of lock.

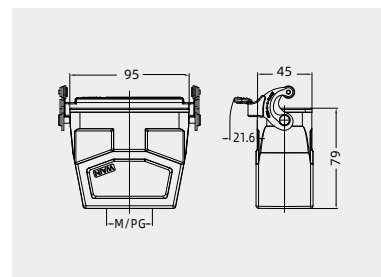

### Bulkhead mounted housings



Thread	Designation	Order No.
---	WV16B-BK-1L/SC	124 116 321 1101
	with plastic cover	
---	WV16B-BK-1L/SC-CV	111 116 321 8003
	with metal cover	
---	WV16B-BK-1L/SC-MCV	111 116 321 8004

Please refer to page 15-02 for choosing proper model of lock.

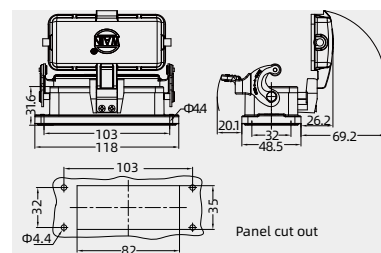

# 16B Metal hoods/housings - for high voltage inserts(HVE Series)

Degree of protection: IP67

## Hoods, side entry



Thread	Designation	Order No.
M25	WV16B-SE-4B-M25	124 116 530 1001
M32	WV16B-SE-4B-M32	124 116 530 1002
PG21	WV16B-SE-4B-PG21	124 116 530 1003

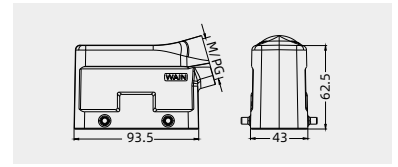

## Hoods, side entry, high construction



Thread	Designation	Order No.
M32	WV16B-SEH-4B-M32	124 116 530 5001
M40	WV16B-SEH-4B-M40	124 116 530 5002
PG21	WV16B-SEH-4B-PG21	124 116 530 5003
PG29	WV16B-SEH-4B-PG29 with sleeve	124 116 530 5004
M32	WV16B-SEH-4B-M32 <i>WS</i>	124 116 530 5007
PG21	WV16B-SEH-4B-PG21 <i>WS</i>	124 116 530 5011
PG29	WV16B-SEH-4B-PG29 <i>WS</i>	124 116 530 5012

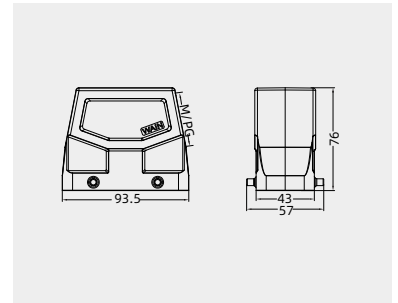

## Hoods, side entry, high construction



Thread	Designation	Order No.
M50	WV16B-SEH-4B-M50	124 116 530 5005
PG36	WV16B-SEH-4B-PG36	124 116 530 5006

Suitable for cable with maximum OD  $\Phi 32\text{mm}$

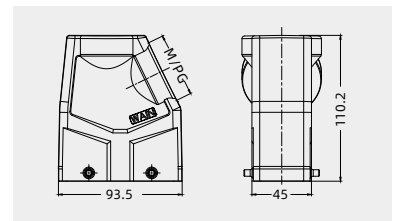

## Hoods, top entry



Thread	Designation	Order No.
M25	WV16B-TE-4B-M25	124 116 430 1001
PG21	WV16B-TE-4B-PG21	124 116 430 1002

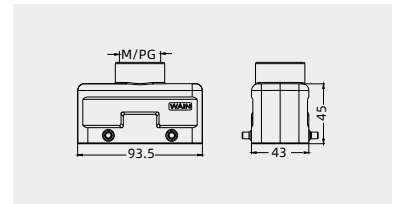

## Hoods, top entry, high construction



Thread	Designation	Order No.
M32	WV16B-TEH-4B-M32	124 116 430 5001
M40	WV16B-TEH-4B-M40	124 116 430 5002
PG21	WV16B-TEH-4B-PG21	124 116 430 5003
PG29	WV16B-TEH-4B-PG29 with sleeve	124 116 430 5004
M32	WV16B-TEH-4B-M32 <i>WS</i>	124 116 430 5007
PG21	WV16B-TEH-4B-PG21 <i>WS</i>	124 116 430 5011
PG29	WV16B-TEH-4B-PG29 <i>WS</i>	124 116 430 5012

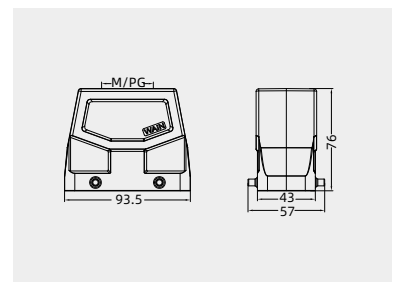

## Hoods, top entry, high construction



Thread	Designation	Order No.
M50	WV16B-TEH-4B-M50	124 116 430 5005
PG36	WV16B-TEH-4B-PG36	124 116 430 5006

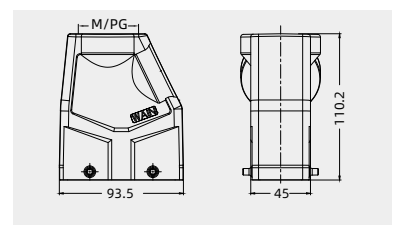

## 16B Metal hoods/housings - for high voltage inserts(HVE Series)

Degree of protection: IP67

### Bulkhead mounted housings



Thread	Designation	Order No.
---	WV16B-BK-2L/SC	124 116 341 1101

Please refer to page 15-02 for choosing proper model of lock.

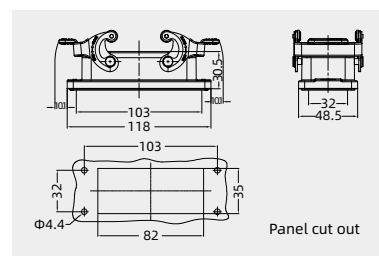

### Housings, cable to cable



Thread	Designation	Order No.
M25	WV16B-CCT-2L/SC-M25	124 116 741 1001
PG21	WV16B-CCT-2L/SC-PG21	124 116 741 1002

Please refer to page 15-02 for choosing proper model of lock.

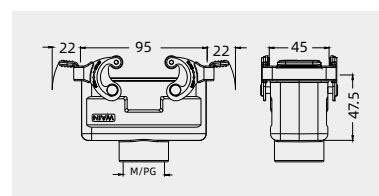

### Housings, cable to cable, high construction



Thread	Designation	Order No.
M32	WV16B-CCTH-2L/SC-M32	124 116 741 5001
M40	WV16B-CCTH-2L/SC-M40	124 116 741 5002
PG21	WV16B-CCTH-2L/SC-PG21	124 116 741 5003
PG29	WV16B-CCTH-2L/SC-PG29	124 116 741 5004
	with sleeve	
M32	WV16B-CCTH-2L/SC-M32 WS	124 116 741 5005
PG21	WV16B-CCTH-2L/SC-PG21 WS	124 116 741 5011
PG29	WV16B-CCTH-2L/SC-PG29 WS	124 116 741 5012

Please refer to page 15-02 for choosing proper model of lock.

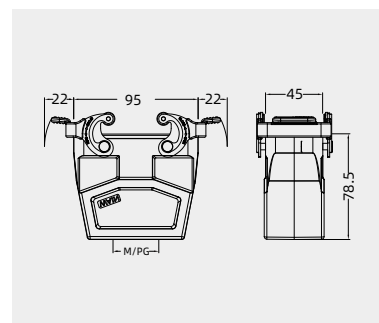

## 16B Metal hoods/housings - for high voltage inserts(HVE Series)

Degree of protection: IP67

### Hoods, side entry



Thread	Designation	Order No.
M25	WV16B-SE-2L/SC-M25	124 116 541 1001
M32	WV16B-SE-2L/SC-M32	124 116 541 1002
PG21	WV16B-SE-2L/SC-PG21	124 116 541 1003

Please refer to page 15-02 for choosing proper model of lock.

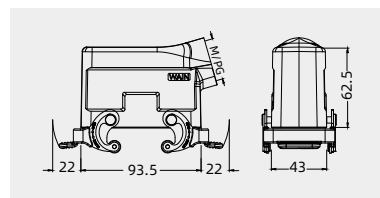

### Hoods, side entry, high construction



Thread	Designation	Order No.
M32	WV16B-SEH-2L/SC-M32	124 116 541 5001
M40	WV16B-SEH-2L/SC-M40	124 116 541 5002
PG21	WV16B-SEH-2L/SC-PG21	124 116 541 5003
PG29	WV16B-SEH-2L/SC-PG29 with sleeve	124 116 541 5004
M32	WV16B-SEH-2L/SC-M32 WS	124 116 541 5006
PG21	WV16B-SEH-2L/SC-PG21 WS	124 116 541 5011
PG29	WV16B-SEH-2L/SC-PG29 WS	124 116 541 5012

Please refer to page 15-02 for choosing proper model of lock.

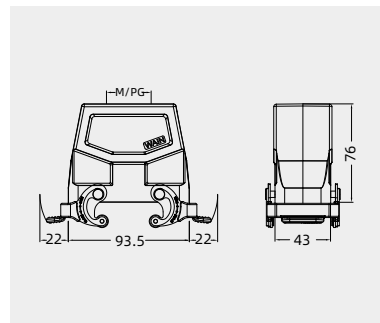

### Hoods, side entry



Thread	Designation	Order No.
M25	WV16B-TE-2L/SC-M25	124 116 441 1001
PG21	WV16B-TE-2L/SC-PG21	124 116 441 1002

Please refer to page 15-02 for choosing proper model of lock.

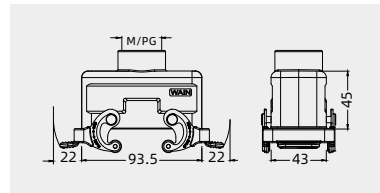

### Hoods, side entry, high construction



Thread	Designation	Order No.
M32	WV16B-TEH-2L/SC-M32	124 116 441 5001
M40	WV16B-TEH-2L/SC-M40	124 116 441 5002
PG21	WV16B-TEH-2L/SC-PG21	124 116 441 5003
PG29	WV16B-TEH-2L/SC-PG29 with sleeve	124 116 441 5004
M32	WV16B-TEH-2L/SC-M32 WS	124 116 441 5005
PG21	WV16B-TEH-2L/SC-PG21 WS	124 116 441 5011
PG29	WV16B-TEH-2L/SC-PG29 WS	124 116 441 5012

Please refer to page 15-02 for choosing proper model of lock.

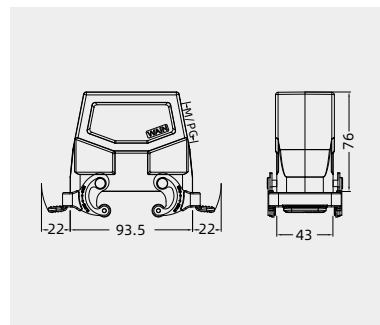

## 16B Metal hoods/housings - for high voltage inserts(HVE Series)

Degree of protection: IP67

### Bulkhead mounted housings



Thread	Designation	Order No.
---	WV16B-BK-4B	124 116 330 1101

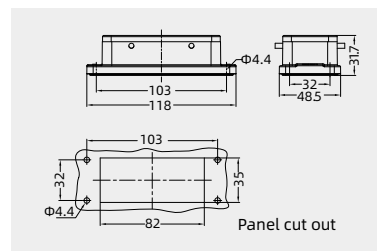

### Hoods, side entry, high construction



Thread	Designation	Order No.
M32	WV16B-SEH-1L/C-M32	124 116 550 5001
PG21	WV16B-SEH-1L/C-PG21	124 116 550 5002
PG29	WV16B-SEH-1L/C-PG29 with sleeve	124 116 550 5003
M32	WV16B-SEH-1L/C-M32 <a href="#">WS</a>	124 116 555 5004
PG21	WV16B-SEH-1L/C-PG21 <a href="#">WS</a>	124 116 555 5011
PG29	WV16B-SEH-1L/C-PG29 <a href="#">WS</a>	124 116 555 5012

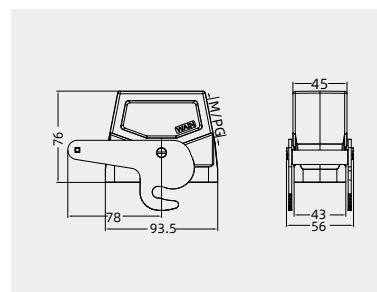

### Bulkhead mounted housings



Thread	Designation	Order No.
---	WV16B-BK-2B/C	124 116 350 1101

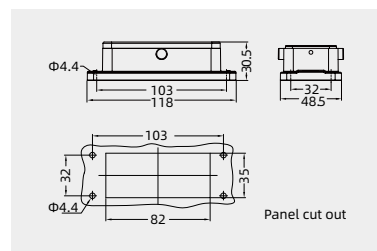

## 24B Plastic hoods/housings

Degree of protection: IP65

## Hoods, side entry, high construction



Thread	Designation	Order No.
M32	H24B.P-SEH-4B-M32	117 024 530 5004
M40	H24B.P-SEH-4B-M40	117 024 530 5005

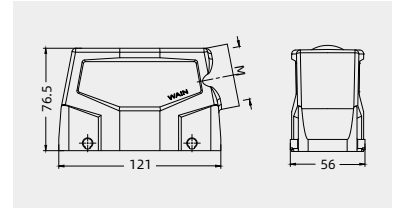

## Hoods, side entry, high construction



Thread	Designation	Order No.
M50	H24B.P-SEH-4B-M50	117 024 530 5502

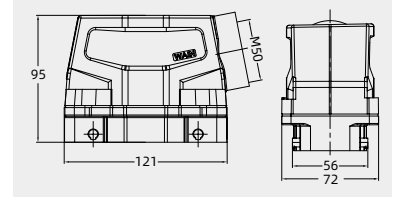

## Hoods, top entry, high construction



Thread	Designation	Order No.
M32	H24B.P-TEH-4B-M32	117 024 430 5004
M40	H24B.P-TEH-4B-M40	117 024 430 5005

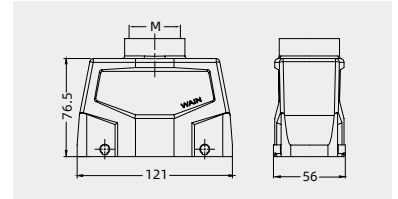

## Hoods, top entry, high construction



Thread	Designation	Order No.
2M25	H24B.P-TEH-4B-2M25	117 024 430 5002
2M32	H24B.P-TEH-4B-2M32	117 024 430 5001

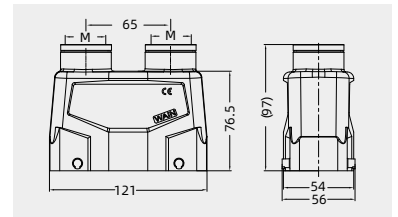

H

Degree of protection: IP65

Bulkhead mounted housings



Connect way	Designation	Order No.
---	H24B.P-BK-2L	117 024 347 1001

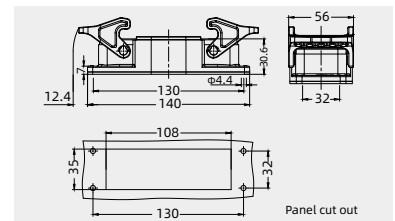

Surface mounted housings, high construction



Thread	Designation	Order No.
M32	H24B.P-SFH-2L-M32	117 024 247 5004
2M32	H24B.P-SFH-2L-2M32	117 024 247 5024
M40	H24B.P-SFH-2L-M40	117 024 247 5005
2M40	H24B.P-SFH-2L-2M40	117 024 247 5025

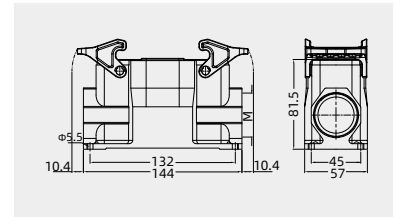

Protection covers, for housings



Connect way	Designation	Order No.
---	H24B.P-CV-4B/2	117 024 030 8002

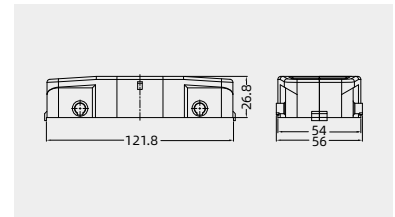

Protection covers, for hoods



Connect way	Designation	Order No.
---	H24B.P-CV-2L/1	117 024 047 8001

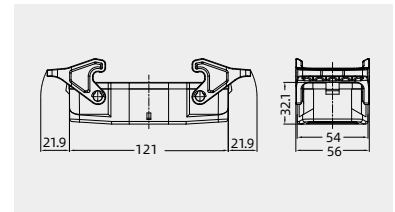

## 24B Modular type plastic hoods/housings

Degree of protection: IP65

Number of modules: 7

## Hoods, side entry, high construction



Thread	Designation	Order No.
M32	HM24B.P-SEH-4B-M32	129 024 530 1500
M40	HM24B.P-SEH-4B-M40	129 024 530 5001

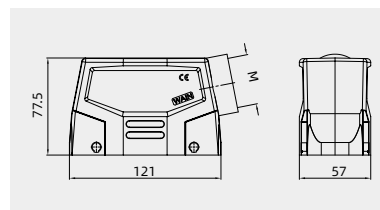

## Hoods, top entry, high construction



Thread	Designation	Order No.
M32	HM24B.P-TEH-4B-M32	129 024 430 1500
M40	HM24B.P-TEH-4B-M40	129 024 430 5001

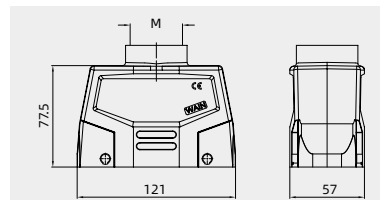

## Hoods, side entry, high construction



Thread	Designation	Order No.
M32	HM24B.P-SEH-2L-M32	129 024 547 1500
M40	HM24B.P-SEH-2L-M40	129 024 540 1001

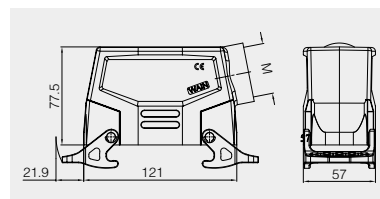

## Hoods, top entry, high construction



Thread	Designation	Order No.
M32	HM24B.P-TEH-2L-M32	129 024 447 1500
M40	HM24B.P-TEH-2L-M40	129 024 440 1001

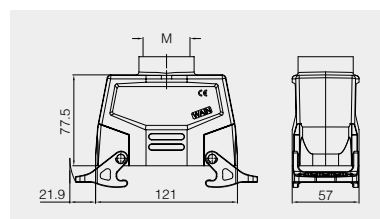

## Surface mounted housings, high construction



Thread	Designation	Order No.
M32	HM24B.P-SFH-2L-M32	129 024 247 1501
M32	HM24B.P-SFH-2L-2M32	129 024 247 1502
M40	HM24B.P-SFH-2L-M40	129 024 230 5001
M40	HM24B.P-SFH-2L-2M40	129 024 247 1500

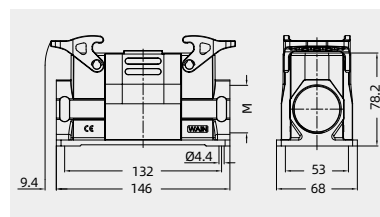



Degree of protection: IP65

Number of modules: 7

Bulkhead mounted housings



Thread	Designation	Order No.
---	HM24B.P-BK-2L	129 024 340 1001

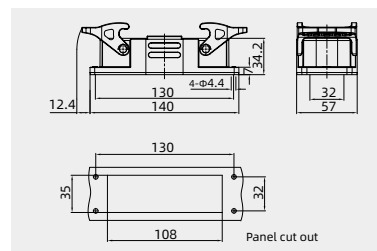

Bulkhead mounted housings



Thread	Designation	Order No.
---	HM24B.P-BK-4B	129 024 330 1001

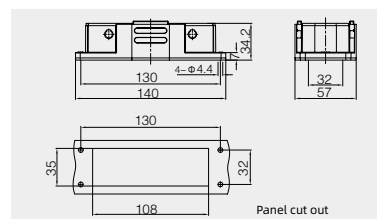

Protection covers, for housings



Connect way	Designation	Order No.
	HM24B.P-CV-4B/2	129 024 030 8001

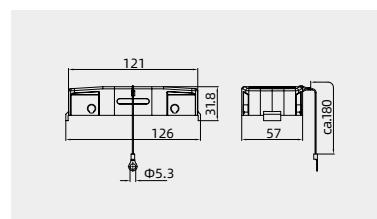

Protection covers, for hoods



Connect way	Designation	Order No.
	HM24B.P-CV-2L/1	129 024 040 8001

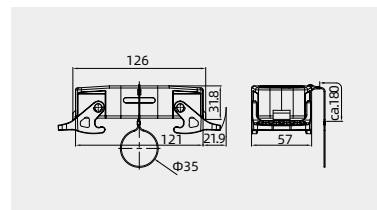

## 24B Metal hoods/housings

Degree of protection: IP65

## Hoods, side entry



Thread	Designation	Order No.
M25	H24B-SE-2B-M25	111 024 515 1003
M32	H24B-SE-2B-M32	111 024 515 1004
PG21	H24B-SE-2B-PG21	111 024 515 1011

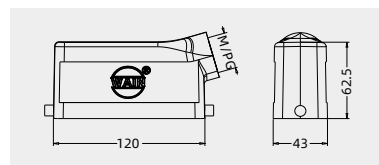

## Hoods, side entry, high construction



Thread	Designation	Order No.
---	W24B-BEH-2B	111 124 910 5002
M32	W24B-SEH-2B-M32	111 124 510 5001
M40	W24B-SEH-2B-M40	111 124 510 5002
PG21	W24B-SEH-2B-PG21	111 124 510 5003
PG29	W24B-SEH-2B-PG29	111 124 510 5004
M32	W24B-SEH-2B-M32 WS	111 124 515 5004
PG21	W24B-SEH-2B-PG21 WS	111 124 515 5011
PG29	W24B-SEH-2B-PG29 WS	111 124 515 5012

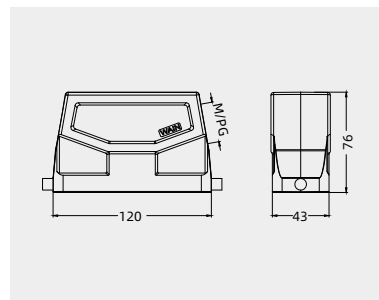

## Hoods, top entry



Thread	Designation	Order No.
M25	H24B-TE-2B-M25	111 024 415 1003
M32	H24B-TE-2B-M32	111 024 415 1004
PG21	H24B-TE-2B-PG21	111 024 415 1011
PG29	H24B-TE-2B-PG29	111 024 415 1012

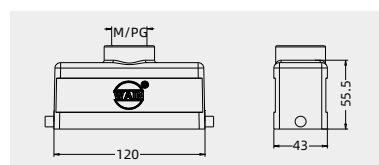

## Hoods, top entry, high construction



Thread	Designation	Order No.
---	W24B-BEH-2B	111 124 910 5002
M32	W24B-TEH-2B-M32	111 124 410 5001
M40	W24B-TEH-2B-M40	111 124 410 5002
PG21	W24B-TEH-2B-PG21	111 124 410 5003
PG29	W24B-TEH-2B-PG29	111 124 410 5004
M32	W24B-TEH-2B-M32 WS	111 124 415 5004
PG21	W24B-TEH-2B-PG21 WS	111 124 415 5011
PG29	W24B-TEH-2B-PG29 WS	111 124 415 5012

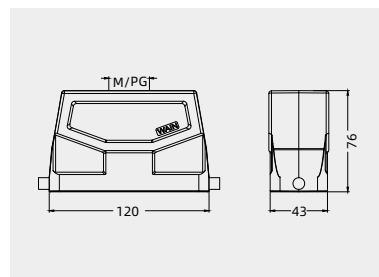

## Housings, cable to cable



Thread	Designation	Order No.
M25	H24B-CCT-1L/SC-M25	111 024 721 1003
M32	H24B-CCT-1L/SC-M32	111 024 721 1004
PG21	H24B-CCT-1L/SC-PG21	111 024 721 1011
PG29	H24B-CCT-1L/SC-PG29	111 024 721 1012

Please refer to page 15-02 for choosing proper model of lock.

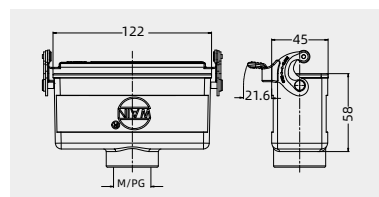

## Housings, cable to cable, high construction



Thread	Designation	Order No.
M32	W24B-CCTH-1L/SC-M32	111 124 721 5002
M40	W24B-CCTH-1L/SC-M40	111 124 721 5003
PG21	W24B-CCTH-1L/SC-PG21	111 124 721 5004
PG29	W24B-CCTH-1L/SC-PG29	111 124 721 5005
M32	W24B-CCTH-1L/SC-M32 WS	111 124 721 5006
PG21	W24B-CCTH-1L/SC-PG21 WS	111 124 721 5011
PG29	W24B-CCTH-1L/SC-PG29 WS	111 124 721 5012

Please refer to page 15-02 for choosing proper model of lock.

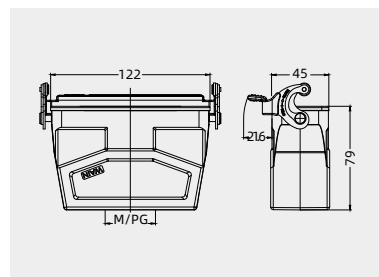

24B Metal hoods/housings

Degree of protection: IP65

Bulkhead mounted housings



Thread	Designation	Order No.
---	H24B-BK-1L/SC	111 024 321 1001
	with plastic cover	
---	H24B-BK-1L/SC-CV	111 024 361 1001
	with metal cover	
---	H24B-BK-1L/SC-MCV	111 024 361 1101

Please refer to page 15-02 for choosing proper model of lock.

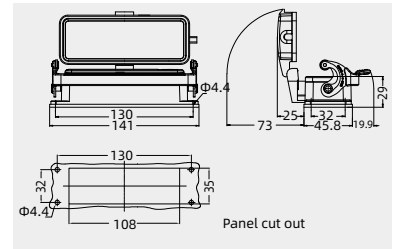

BK hole cover plate



Applications	Designation	Order No.
---	24B-BK/MCV	111 024 390 8001

The mounting holes of the mounting cabinet can be temporarily sealed. Applicable to the case that the mounting hole has been opened and the connector has not been installed.

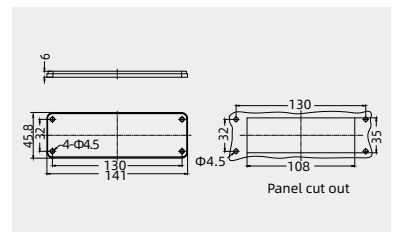

Surface mounted housings



Thread	Designation	Order No.
M25	H24B-SF-1L/SC-M25	111 024 221 1003
2M25	H24B-SF-1L/SC-2M25	111 024 221 1023
PG21	H24B-SF-1L/SC-PG21	111 024 221 1011
2PG21	H24B-SF-1L/SC-2PG21	111 024 221 1031
	with plastic cover	
M25	H24B-SF-1L/SC-CV-M25	111 024 261 1003
2M25	H24B-SF-1L/SC-CV-2M25	111 024 261 1023
PG21	H24B-SF-1L/SC-CV-PG21	111 024 261 1011
2PG21	H24B-SF-1L/SC-CV-2PG21	111 024 261 1031
	with metal cover	
M25	H24B-SF-1L/SC-MCV-M25	111 024 261 1103
2M25	H24B-SF-1L/SC-MCV-2M25	111 024 261 1123
PG21	H24B-SF-1L/SC-MCV-PG21	111 024 261 1111
2PG21	H24B-SF-1L/SC-MCV-2PG21	111 024 261 1131

Please refer to page 15-02 for choosing proper model of lock.

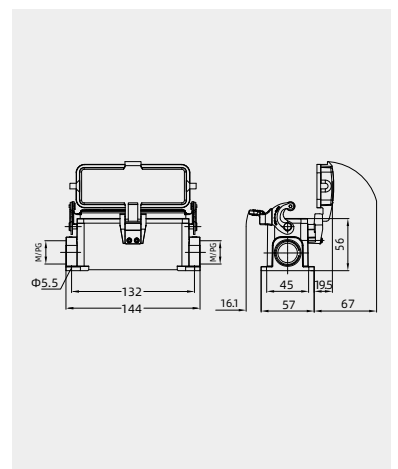

Surface mounted housings, high construction



Thread	Designation	Order No.
M32	H24B-SFH-1L/SC-M32	111 024 221 5004
2M32	H24B-SFH-1L/SC-2M32	111 024 221 5024
PG21	H24B-SFH-1L/SC-PG21	111 024 221 5011
2PG21	H24B-SFH-1L/SC-2PG21	111 024 221 5031
PG29	H24B-SFH-1L/SC-PG29	111 024 221 5012
2PG29	H24B-SFH-1L/SC-2PG29	111 024 221 5032
	with plastic cover	
M32	H24B-SFH-1L/SC-CV-M32	111 024 261 5004
2M32	H24B-SFH-1L/SC-CV-2M32	111 024 261 5024
PG21	H24B-SFH-1L/SC-CV-PG21	111 024 261 5011
2PG21	H24B-SFH-1L/SC-CV-2PG21	111 024 261 5031
PG29	H24B-SFH-1L/SC-CV-PG29	111 024 261 5012
2PG29	H24B-SFH-1L/SC-CV-2PG29	111 024 261 5032
	with metal cover	
M32	H24B-SFH-1L/SC-MCV-M32	111 024 261 5104
2M32	H24B-SFH-1L/SC-MCV-2M32	111 024 261 5124
PG21	H24B-SFH-1L/SC-MCV-PG21	111 024 261 5111
2PG21	H24B-SFH-1L/SC-MCV-2PG21	111 024 261 5131
PG29	H24B-SFH-1L/SC-MCV-PG29	111 024 261 5112
2PG29	H24B-SFH-1L/SC-MCV-2PG29	111 024 261 5132

Please refer to page 15-02 for choosing proper model of lock.

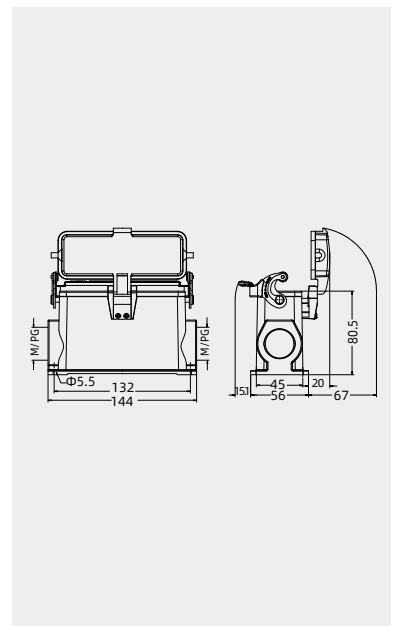

## 24B Metal hoods/housings

Degree of protection: IP65

## Hoods, side entry



Thread	Designation	Order No.
M25	H24B-SE-4B-M25	111 024 530 1003
M32	H24B-SE-4B-M32	111 024 530 1004
PG21	H24B-SE-4B-PG21	111 024 530 1011

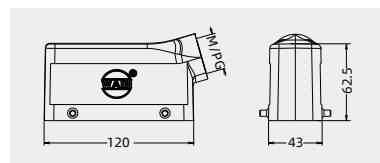

## Hoods, side entry, high construction



Thread	Designation	Order No.
---	W24B-BEH-4B	111 124 930 5003
M32	W24B-SEH-4B-M32	111 124 530 5001
M40	W24B-SEH-4B-M40	111 124 530 5002
PG21	W24B-SEH-4B-PG21	111 124 530 5003
PG29	W24B-SEH-4B-PG29	111 124 530 5004
M32	W24B-SEH-4B-M32 <i>WS</i>	111 124 530 5008
PG21	W24B-SEH-4B-PG21 <i>WS</i>	111 124 530 5011
PG29	W24B-SEH-4B-PG29 <i>WS</i>	111 124 530 5012

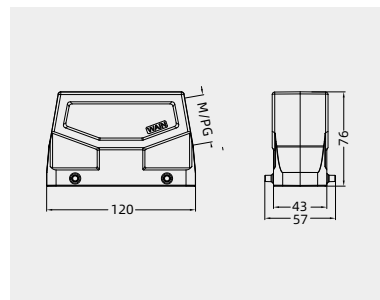

## Hoods, top entry



Thread	Designation	Order No.
M25	H24B-TE-4B-M25	111 024 430 1003
M32	H24B-TE-4B-M32	111 024 430 1004
PG21	H24B-TE-4B-PG21	111 024 430 1011
PG29	H24B-TE-4B-PG29	111 024 430 1012

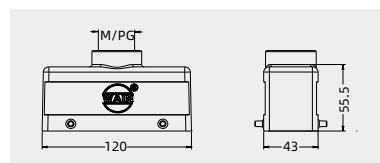

## Hoods, top entry, high construction



Thread	Designation	Order No.
---	W24B-BEH-4B	111 124 930 5003
M32	W24B-TEH-4B-M32	111 124 430 5001
M40	W24B-TEH-4B-M40	111 124 430 5002
PG21	W24B-TEH-4B-PG21	111 124 430 5003
PG29	W24B-TEH-4B-PG29	111 124 430 5004
2M32	W24B-TEH-4B-2M32	111 124 430 5005
M32	W24B-TEH-4B-M32 <i>WS</i>	111 124 430 5014
PG21	W24B-TEH-4B-PG21 <i>WS</i>	111 124 430 5011
PG29	W24B-TEH-4B-PG29 <i>WS</i>	111 124 430 5010

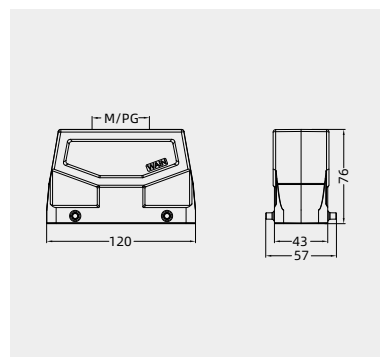

## 24B Metal hoods/housings

Degree of protection: IP65

## Bulkhead mounted housings



Thread	Designation	Order No.
---	H24B-BK-2L/SC	111 024 341 1001

Please refer to page 15-02 for choosing proper model of lock.

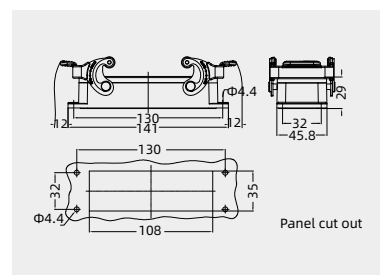

## Surface mounted housings



Thread	Designation	Order No.
M25	H24B-SF-2L/SC-M25	111 024 241 1003
2M25	H24B-SF-2L/SC-2M25	111 024 241 1023
PG21	H24B-SF-2L/SC-PG21	111 024 241 1011
2PG21	H24B-SF-2L/SC-2PG21	111 024 241 1031

Please refer to page 15-02 for choosing proper model of lock.

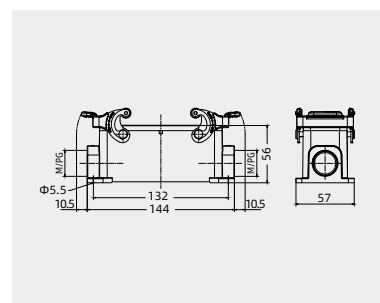

## Surface mounted housings, high construction



Thread	Designation	Order No.
M32	H24B-SFH-2L/SC-M32	111 024 241 5004
2M32	H24B-SFH-2L/SC-2M32	111 024 241 5024
2M40	H24B-SFH-2L/SC-2M40	111 024 241 5025
PG21	H24B-SFH-2L/SC-PG21	111 024 241 5011
2PG21	H24B-SFH-2L/SC-2PG21	111 024 241 5031
PG29	H24B-SFH-2L/SC-PG29	111 024 241 5012
2PG29	H24B-SFH-2L/SC-2PG29	111 024 241 5032

Please refer to page 15-02 for choosing proper model of lock.

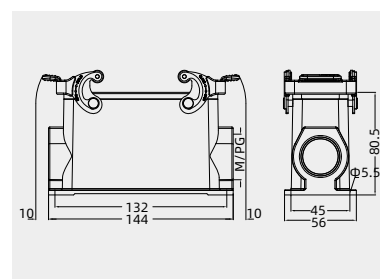

## Housings, cable to cable



Thread	Designation	Order No.
M25	H24B-CCT-2L/SC-M25	111 024 741 1003
M32	H24B-CCT-2L/SC-M32	111 024 741 1004
PG21	H24B-CCT-2L/SC-PG21	111 024 741 1011
PG29	H24B-CCT-2L/SC-PG29	111 024 741 1012

Please refer to page 15-02 for choosing proper model of lock.

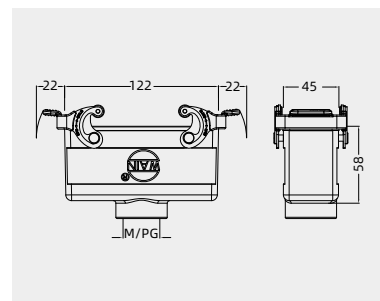

24B Metal hoods/housings

Degree of protection: IP65

Housings, cable to cable, high construction



Thread	Designation	Order No.
M32	W24B-CCTH-2L/SC-M32	111 124 741 5002
M40	W24B-CCTH-2L/SC-M40	111 124 741 5003
PG21	W24B-CCTH-2L/SC-PG21	111 124 741 5004
PG29	W24B-CCTH-2L/SC-PG29	111 124 741 5005
	with sleeve	
M32	W24B-CCTH-2L/SC-M32 WS	111 124 741 5010
PG21	W24B-CCTH-2L/SC-PG21 WS	111 124 741 5011
PG29	W24B-CCTH-2L/SC-PG29 WS	111 124 741 5012

Please refer to page 15-02 for choosing proper model of lock.

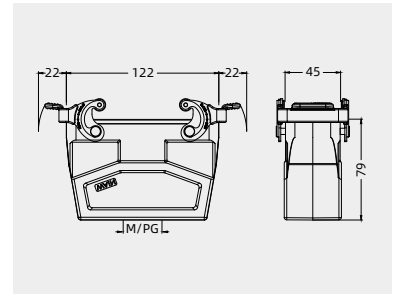

Protection covers, plastic



Connect way	Applications	Designation	Order No.
---	for hoods	H24B-CV-4C	111 024 090 8009

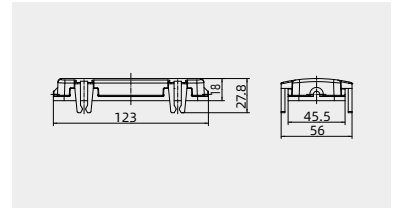

H

Protection covers, plastic



Connect way	Applications	Designation	Order No.
	for Housings, cable to cable	H24B-CV-4B/1	111 024 030 8001
	for Housings, bulkhead mounting / surface mounting	H24B-CV-4B/2	111 024 030 8002

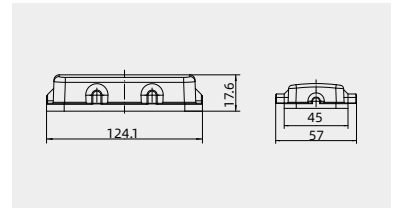

## 24B Metal hoods/housings

Degree of protection: IP65

## Hoods, side entry



Thread	Designation	Order No.
M25	H24B-SE-2L/SC-M25	111 024 541 1003
M32	H24B-SE-2L/SC-M32	111 024 541 1004
PG21	H24B-SE-2L/SC-PG21	111 024 541 1011

Please refer to page 15-02 for choosing proper model of lock.

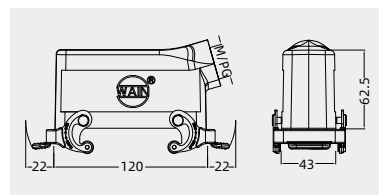

## Hoods, side entry, high construction



Thread	Designation	Order No.
M32	W24B-SEH-2L/SC-M32	111 124 541 5001
M40	W24B-SEH-2L/SC-M40	111 124 541 5002
PG21	W24B-SEH-2L/SC-PG21	111 124 541 5003
PG29	W24B-SEH-2L/SC-PG29	111 124 541 5004
	with sleeve	
M32	W24B-SEH-2L/SC-M32 WS	111 124 541 5005
PG21	W24B-SEH-2L/SC-PG21 WS	111 124 541 5011
PG29	W24B-SEH-2L/SC-PG29 WS	111 124 541 5012

Please refer to page 15-02 for choosing proper model of lock.

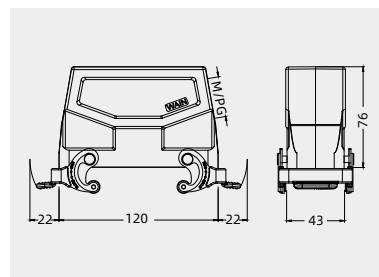

## Hoods, top entry



Thread	Designation	Order No.
M25	H24B-TE-2L/SC-M25	111 024 441 1003
M32	H24B-TE-2L/SC-M32	111 024 441 1004
PG21	H24B-TE-2L/SC-PG21	111 024 441 1011
PG29	H24B-TE-2L/SC-PG29	111 024 441 1012

Please refer to page 15-02 for choosing proper model of lock.

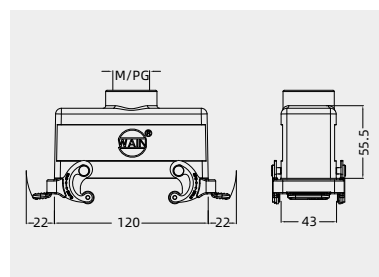

## Hoods, top entry, high construction



Thread	Designation	Order No.
M32	W24B-TEH-2L/SC-M32	111 124 441 5001
M40	W24B-TEH-2L/SC-M40	111 124 441 5002
PG21	W24B-TEH-2L/SC-PG21	111 124 441 5003
PG29	W24B-TEH-2L/SC-PG29	111 124 441 5004
	with sleeve	
M32	W24B-TEH-2L/SC-M32 WS	111 124 441 5006
PG21	W24B-TEH-2L/SC-PG21 WS	111 124 441 5011
PG29	W24B-TEH-2L/SC-PG29 WS	111 124 441 5012

Please refer to page 15-02 for choosing proper model of lock.

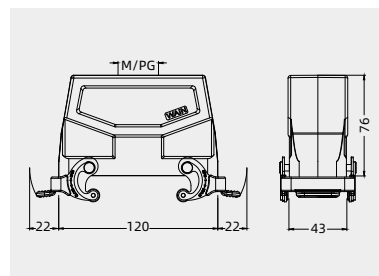

## Bulkhead mounted housings



Thread	Designation	Order No.
---	H24B-BK-4B	111 024 330 1001
	with plastic cover	
---	H24B-BK-4B-CV	111 024 370 1001
	with metal cover	
---	H24B-BK-4B-MCV	111 024 370 1101

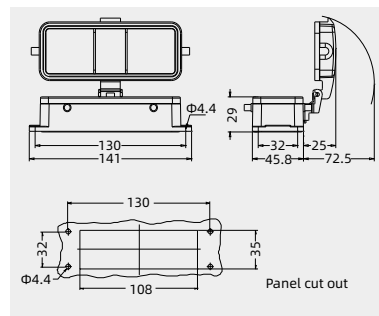

## 24B Metal hoods/housings

Degree of protection: IP65

## Surface mounted housings



Thread	Designation	Order No.
M25	H24B-SF-4B-M25	111 024 230 1003
2M25	H24B-SF-4B-2M25	111 024 230 1023
PG21	H24B-SF-4B-PG21	111 024 230 1011
2PG21	H24B-SF-4B-2PG21	111 024 230 1031
with plastic cover		
M25	H24B-SF-4B-CV-M25	111 024 270 1003
2M25	H24B-SF-4B-CV-2M25	111 024 270 1023
PG21	H24B-SF-4B-CV-PG21	111 024 270 1011
2PG21	H24B-SF-4B-CV-2PG21	111 024 270 1031
with metal cover		
M25	H24B-SF-4B-MCV-M25	111 024 270 1103
2M25	H24B-SF-4B-MCV-2M25	111 024 270 1123
PG21	H24B-SF-4B-MCV-PG21	111 024 270 1111
2PG21	H24B-SF-4B-MCV-2PG21	111 024 270 1131

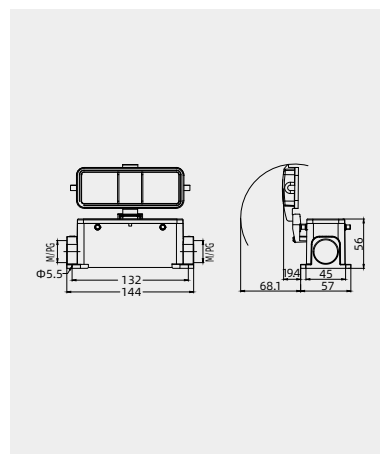

## Surface mounted housings, high construction



Thread	Designation	Order No.
M32	H24B-SFH-4B-M32	111 024 230 5004
2M32	H24B-SFH-4B-2M32	111 024 230 5024
PG21	H24B-SFH-4B-PG21	111 024 230 5011
2PG21	H24B-SFH-4B-2PG21	111 024 230 5031
PG29	H24B-SFH-4B-PG29	111 024 230 5012
2PG29	H24B-SFH-4B-2PG29	111 024 230 5032
with plastic cover		
M32	H24B-SFH-4B-CV-M32	111 024 270 5004
2M32	H24B-SFH-4B-CV-2M32	111 024 270 5024
PG21	H24B-SFH-4B-CV-PG21	111 024 270 5011
2PG21	H24B-SFH-4B-CV-2PG21	111 024 270 5031
PG29	H24B-SFH-4B-CV-PG29	111 024 270 5012
2PG29	H24B-SFH-4B-CV-2PG29	111 024 270 5032
with metal cover		
M32	H24B-SFH-4B-MCV-M32	111 024 270 5104
2M32	H24B-SFH-4B-MCV-2M32	111 024 270 5124
PG21	H24B-SFH-4B-MCV-PG21	111 024 270 5111
2PG21	H24B-SFH-4B-MCV-2PG21	111 024 270 5131
PG29	H24B-SFH-4B-MCV-PG29	111 024 270 5112
2PG29	H24B-SFH-4B-MCV-2PG29	111 024 270 5132

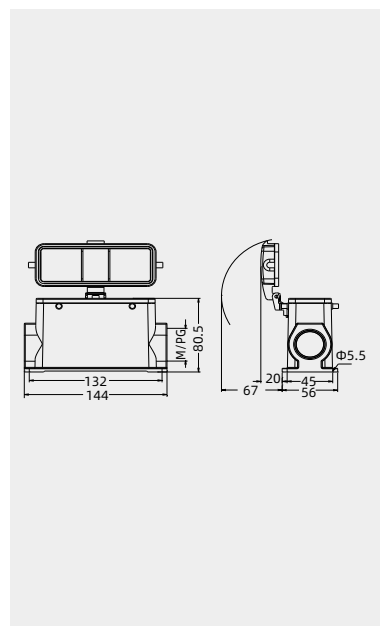

## Protection covers, metal



Connect way	Applications	Designation	Order No.
	for hoods	H24B-MCV-4B/1S	111 024 030 8103
	for housings, without sealing	H24B-MCV-4B/2	111 024 030 8102

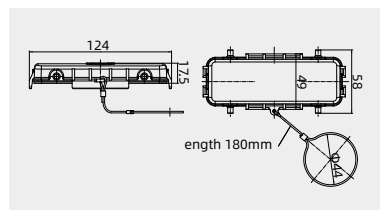

## Protection covers, metal



Connect way	Applications	Designation	Order No.
	for hoods	H24B-MCV-2L/SC.1S	111 024 041 8101
	or housings	H24B-MCV-2L/SC.2	111 024 041 8102

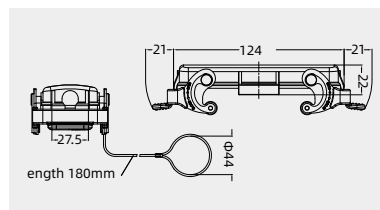

Please refer to page 15-02 for choosing proper model of lock.



24B Metal hoods/housings

Degree of protection: IP65

Protection covers, metal



Connect way	Applications	Designation	Order No.
	for hoods	H24B-MCV-1L/SC.1S	111 024 021 1101

Please refer to page 15-02 for choosing proper model of lock.

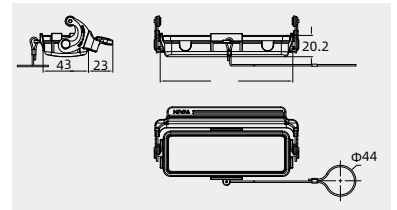

Protection covers(IP5X)



Thread	Applications	Designation	Order No.
---	for housings	H24B-CV/C	111 024 000 8004

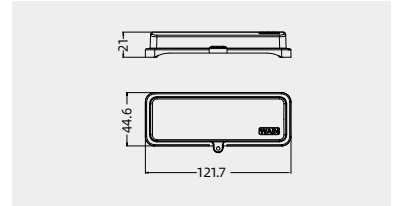

Hoods, side entry, high construction



Thread	Designation	Order No.
M25	W24B-SEH-1L/C-M25	111 124 550 5001
M32	W24B-SEH-1L/C-M32	111 124 550 5002
M40	W24B-SEH-1L/C-M40	111 124 550 5003
PG21	W24B-SEH-1L/C-PG21	111 124 550 5004
PG29	W24B-SEH-1L/C-PG29	111 124 550 5005
	with sleeve	
M32	W24B-SEH-1L/C-M32 WS	111 124 555 5004
PG21	W24B-SEH-1L/C-PG21 WS	111 124 555 5011
PG29	W24B-SEH-1L/C-PG29 WS	111 124 555 5012

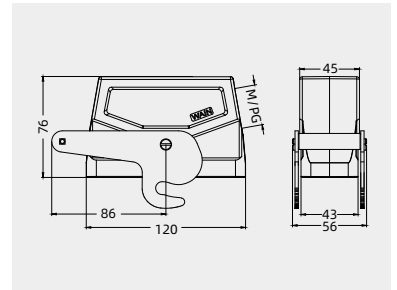

Bulkhead mounted housings



Thread	Designation	Order No.
---	H24B-BK-2B/C	111 024 355 1001

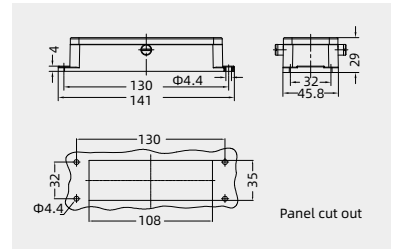

## 24B Metal hoods/housings

Degree of protection: IP65

## Hoods, side entry, high construction



Thread	Designation	Order No.
M40	W24B-SEH-1L/B-M40	111 024 525 5105
PG29	W24B-SEH-1L/B-PG29 with sleeve	111 024 525 5112
M32	W24B-SEH-1L/B-M32 <i>WS</i>	111 124 529 5005
PG21	W24B-SEH-1L/B-PG21 <i>WS</i>	111 124 529 5004
PG29	W24B-SEH-1L/B-PG29 <i>WS</i>	111 124 525 5112

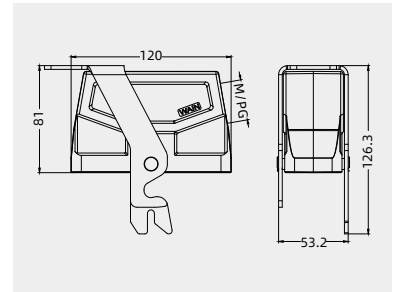

## Bulkhead mounted housings



Thread	Designation	Order No.
---	H24B-BK-2B/B	111 024 315 1101

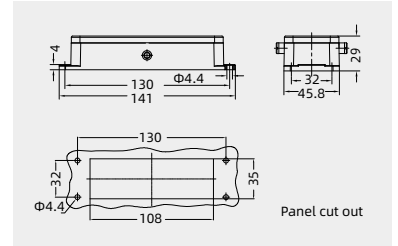

## 24B Metal hoods/housings -Suitable for harsh environment(anti-corrosion)

Degree of protection: IP65

### Hoods, side entry



Thread	Designation	Order No.
M25	H24B-MSE-4B-M25	112 024 530 1003
M32	H24B-MSE-4B-M32	112 024 530 1004
PG21	H24B-MSE-4B-PG21	112 024 530 1011

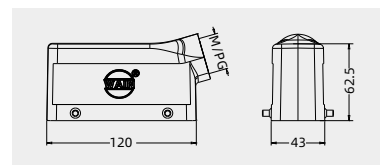

### Hoods, side entry, high construction



Thread	Designation	Order No.
M32	W24B-MSEH-4B-M32	112 124 530 5005
M40	W24B-MSEH-4B-M40	112 124 530 5006
PG21	W24B-MSEH-4B-PG21	112 124 530 5011
PG29	W24B-MSEH-4B-PG29	112 124 530 5007
	with sleeve	
M32	W24B-MSEH-4B-M32 <b>WS</b>	112 124 530 5004
PG21	W24B-MSEH-4B-PG21 <b>WS</b>	112 124 530 5013
PG29	W24B-MSEH-4B-PG29 <b>WS</b>	112 124 530 5012

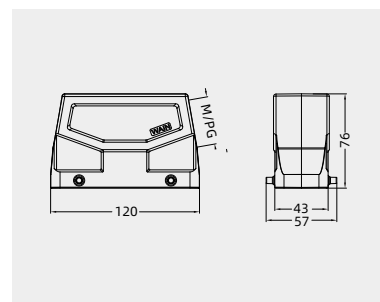

### Hoods, top entry



Thread	Designation	Order No.
M25	H24B-MTE-4B-M25	112 024 430 1003
M32	H24B-MTE-4B-M32	112 024 430 1004
PG21	H24B-MTE-4B-PG21	112 024 430 1011
PG29	H24B-MTE-4B-PG29	112 024 430 1005

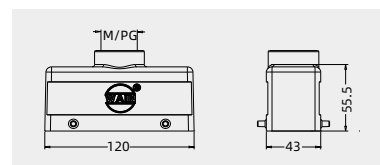

### Hoods, top entry, high construction



Thread	Designation	Order No.
M32	W24B-MTEH-4B-M32	112 124 430 5006
M40	W24B-MTEH-4B-M40	112 124 430 5007
PG21	W24B-MTEH-4B-PG21	112 124 430 5011
PG29	W24B-MTEH-4B-PG29	112 124 430 5008
	with sleeve	
M32	W24B-MTEH-4B-M32 <b>WS</b>	112 124 430 5004
PG21	W24B-MTEH-4B-PG21 <b>WS</b>	112 124 430 5010
PG29	W24B-MTEH-4B-PG29 <b>WS</b>	112 124 430 5012

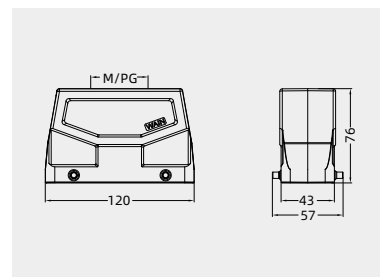

### Bulkhead mounted housings



Thread	Designation	Order No.
---	H24B-MBK-2L/ <b>SC</b>	112 024 341 1001

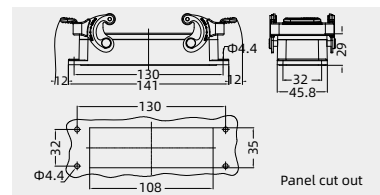

### Surface mounted housings



Thread	Designation	Order No.
M25	H24B-MSF-2L/ <b>SC</b> -M25	112 024 241 1003
2M25	H24B-MSF-2L/ <b>SC</b> -2M25	112 024 241 1023
PG21	H24B-MSF-2L/ <b>SC</b> -PG21	112 024 241 1011
2PG21	H24B-MSF-2L/ <b>SC</b> -2PG21	112 024 241 1031

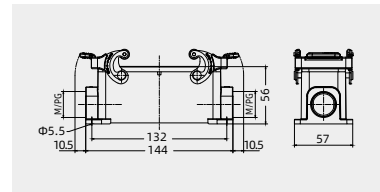

## 24B Metal hoods/housings -Suitable for harsh environment(anti-corrosion)

Degree of protection: IP65

Surface mounted housings, high construction



Thread	Designation	Order No.
M32	H24B-MSFH-2L/SC-M32	112 024 241 5004
2M32	H24B-MSFH-2L/SC-2M32	112 024 241 5024
M40	H24B-MSFH-2L/SC-M40	112 024 241 5005
PG21	H24B-MSFH-2L/SC-PG21	112 024 241 5011
2PG21	H24B-MSFH-2L/SC-2PG21	112 024 241 5031
PG29	H24B-MSFH-2L/SC-PG29	112 024 241 5012
2PG29	H24B-MSFH-2L/SC-2PG29	112 024 241 5032

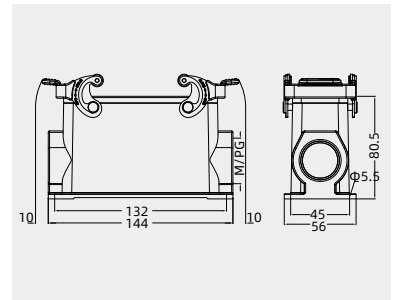

Protection covers



Connect way	Applications	Designation	Order No.
	for hoods	H24B-MMCV-4B/1	112 024 030 8001
	for housings	H24B-MMCV-4B/2	112 024 030 8002

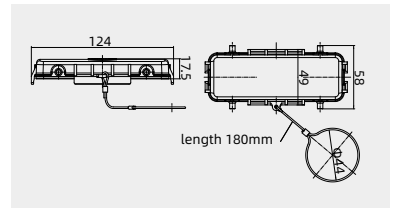

Protection covers



Connect way	Applications	Designation	Order No.
	for hoods	H24B-MMCV-2L/SC.1S	112 024 041 8001
	for housings	H24B-MMCV-2L/SC.2	112 024 041 8002

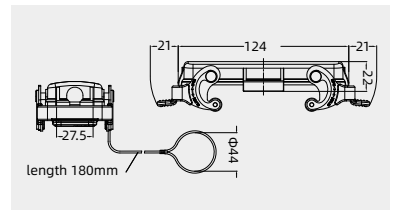

## 24B Metal hoods/housings -Suitable for harsh environment(anti-corrosion)

Degree of protection: IP65

### Hoods, side entry, high construction



Thread	Designation	Order No.
M32	W24B-MSEH-1L/C-M32	112 124 550 5006
PG21	W24B-MSEH-1L/C-PG21	112 124 555 5011
PG29	W24B-MSEH-1L/C-PG29	112 124 550 5007
	with sleeve	
M32	W24B-MSEH-1L/C-M32 <b>WS</b>	112 124 555 5004
PG21	W24B-MSEH-1L/C-PG21 <b>WS</b>	112 124 555 5013
PG29	W24B-MSEH-1L/C-PG29 <b>WS</b>	112 124 555 5012

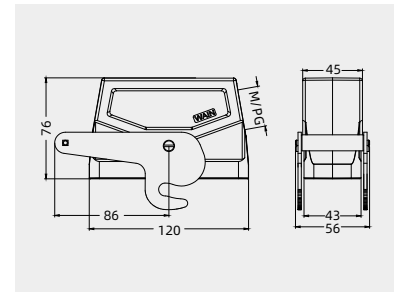

### Bulkhead mounted housings



Thread	Designation	Order No.
---	H24B-MBK-2B/C	112 024 350 1001

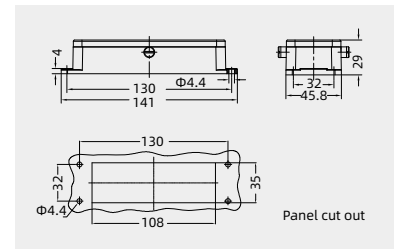

## 24B EMC Metal hoods/housings

Degree of protection: IP65

## Hoods, side entry



Thread	Designation	Order No.
M25	EMC.H24B-SE-4B-M25	111 624 530 1005
M32	EMC.H24B-SE-4B-M32	111 624 535 1004
PG21	EMC.H24B-SE-4B-PG21	111 624 503 1501

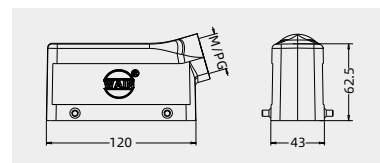

## Hoods, side entry, high construction



Thread	Designation	Order No.
---	EMC.W24B-BEH-4B	111 224 930 5004
M32	EMC.W24B-SEH-4B-M32	111 224 530 5008
M40	EMC.W24B-SEH-4B-M40	111 224 530 5009
PG21	EMC.W24B-SEH-4B-PG21	111 224 530 5006
PG29	EMC.W24B-SEH-4B-PG29	111 224 530 5010
	with sleeve	
M32	EMC.W24B-SEH-4B-M32 <a href="#">WS</a>	111 124 535 5501
PG21	EMC.W24B-SEH-4B-PG21 <a href="#">WS</a>	111 224 535 5001
PG29	EMC.W24B-SEH-4B-PG29 <a href="#">WS</a>	111 124 535 5013

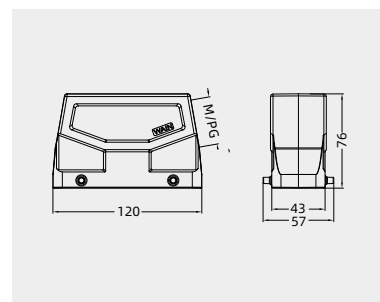

## Hoods, top entry



Thread	Designation	Order No.
M25	EMC.H24B-TE-4B-M25	111 624 435 1003
M32	EMC.H24B-TE-4B-M32	111 624 435 1004
PG21	EMC.H24B-TE-4B-PG21	111 624 435 1011
PG29	EMC.H24B-TE-4B-PG29	111 624 435 1012

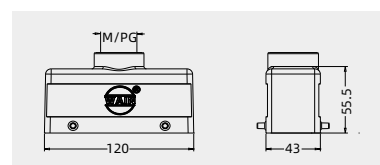

## Hoods, top entry, high construction



Thread	Designation	Order No.
---	EMC.W24B-BEH-4B	111 224 930 5004
M32	EMC.W24B-TEH-4B-M32	111 224 430 5009
M40	EMC.W24B-TEH-4B-M40	111 224 430 5010
PG21	EMC.W24B-TEH-4B-PG21	111 224 430 5001
PG29	EMC.W24B-TEH-4B-PG29	111 224 430 5011
	with sleeve	
M32	EMC.W24B-TEH-4B-M32 <a href="#">WS</a>	111 124 435 5501
PG21	EMC.W24B-TEH-4B-PG21 <a href="#">WS</a>	111 124 435 5502
PG29	EMC.W24B-TEH-4B-PG29 <a href="#">WS</a>	111 124 435 5015

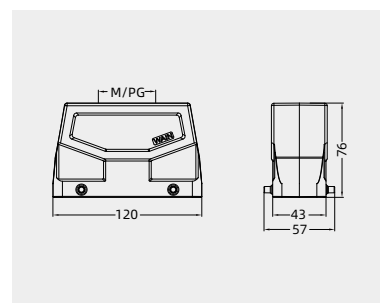

## Bulkhead mounted housings



Thread	Designation	Order No.
---	EMC1.H24B-BK-2L/ <a href="#">SC</a>	111 624 341 1501

Please refer to page 15-02 for choosing proper model of lock.

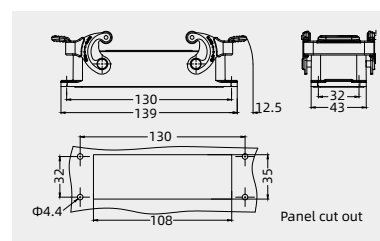

Degree of protection: IP65



Hoods, side entry



Thread	Designation	Order No.
M25	EMC.H24B-SF-2L/SC-M25	111 616 241 1500
2M25	EMC.H24B-SF-2L/SC-2M25	111 616 241 1501
PG21	EMC.H24B-SF-2L/SC-PG21	111 616 241 1502
2PG21	EMC.H24B-SF-2L/SC-2PG21	111 616 241 1503

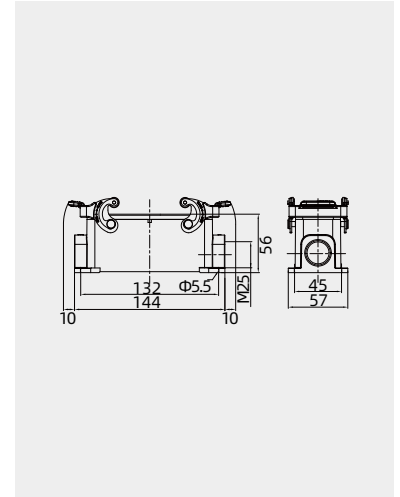

Hoods, side entry, high construction



Thread	Designation	Order No.
M32	EMC.H24B-SFH-2L/SC-M32	111 624 241 5501
2M32	EMC.H24B-SFH-2L/SC-2M32	111 624 241 5502
M40	EMC.H24B-SFH-2L/SC-M40	111 624 241 5503
2M40	EMC.H24B-SFH-2L/SC-2M40	111 624 241 5504
PG21	EMC.H24B-SFH-2L/SC-PG21	111 624 241 5505
2PG21	EMC.H24B-SFH-2L/SC-2PG21	111 624 241 5506
PG29	EMC.H24B-SFH-2L/SC-PG29	111 624 241 5507
2PG29	EMC.H24B-SFH-2L/SC-2PG29	111 624 241 5508

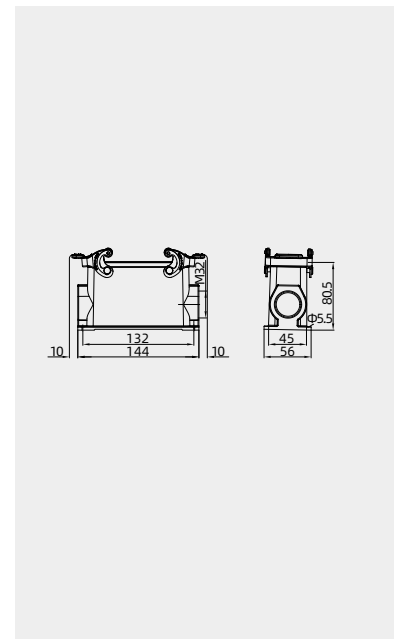

## 24B Metal hoods/housings

Degree of protection: IP67

## Hoods, side entry



Thread	Designation	Order No.
M25	W24B-SE-2B-M25	111 124 510 1001
M32	W24B-SE-2B-M32	111 124 510 1002
PG21	W24B-SE-2B-PG21	111 124 510 1003

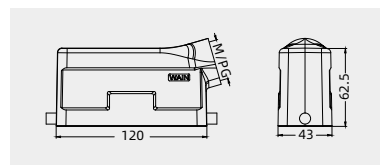

## Hoods, side entry, high construction



Thread	Designation	Order No.
---	W24B-BEH-2B	111 124 910 5002
M32	W24B-SEH-2B-M32	111 124 510 5001
M40	W24B-SEH-2B-M40	111 124 510 5002
PG21	W24B-SEH-2B-PG21	111 124 510 5003
PG29	W24B-SEH-2B-PG29	111 124 510 5004
	with sleeve	
M32	W24B-SEH-2B-M32 <i>WS</i>	111 124 515 5004
PG21	W24B-SEH-2B-PG21 <i>WS</i>	111 124 515 5011
PG29	W24B-SEH-2B-PG29 <i>WS</i>	111 124 515 5012

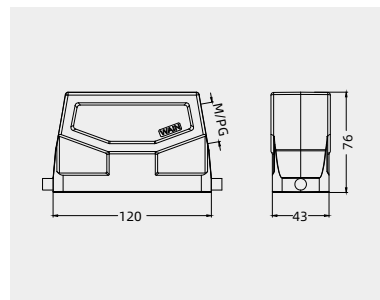

## Hoods, top entry



Thread	Designation	Order No.
M25	W24B-TE-2B-M25	111 124 410 1001
M32	W24B-TE-2B-M32	111 124 410 1002
PG21	W24B-TE-2B-PG21	111 124 410 1003
PG29	W24B-TE-2B-PG29	111 124 410 1004

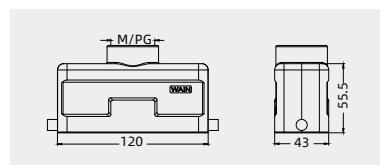

## Hoods, top entry, high construction



Thread	Designation	Order No.
---	W24B-BEH-2B	111 124 910 5002
M32	W24B-TEH-2B-M32	111 124 410 5001
M40	W24B-TEH-2B-M40	111 124 410 5002
PG21	W24B-TEH-2B-PG21	111 124 410 5003
PG29	W24B-TEH-2B-PG29	111 124 410 5004
	with sleeve	
M32	W24B-TEH-2B-M32 <i>WS</i>	111 124 415 5004
PG21	W24B-TEH-2B-PG21 <i>WS</i>	111 124 415 5011
PG29	W24B-TEH-2B-PG29 <i>WS</i>	111 124 415 5012

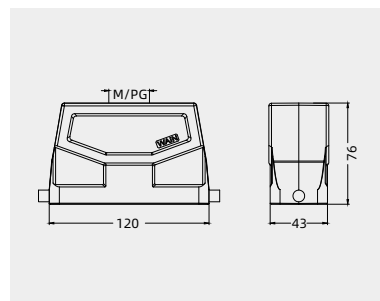



24B Metal hoods/housings

Degree of protection: IP67

Housings, cable to cable



Thread	Designation	Order No.
M25	W24B-CCT-1L/SC-M25	111 124 721 1001
M32	W24B-CCT-1L/SC-M32	111 124 721 1002
PG21	W24B-CCT-1L/SC-PG21	111 124 721 1003
PG29	W24B-CCT-1L/SC-PG29	111 124 721 1004

Please refer to page 15-02 for choosing proper model of lock.

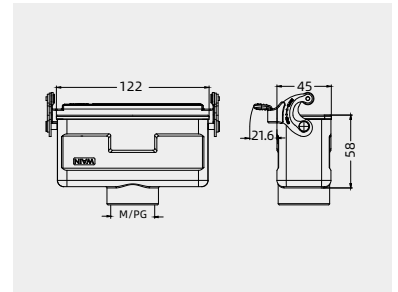

Housings, cable to cable, high construction



Thread	Designation	Order No.
M32	W24B-CCTH-1L/SC-M32	111 124 721 5002
M40	W24B-CCTH-1L/SC-M40	111 124 721 5003
PG21	W24B-CCTH-1L/SC-PG21	111 124 721 5004
PG29	W24B-CCTH-1L/SC-PG29	111 124 721 5005
	with sleeve	
M32	W24B-CCTH-1L/SC-M32 WS	111 124 721 5006
PG21	W24B-CCTH-1L/SC-PG21 WS	111 124 721 5011
PG29	W24B-CCTH-1L/SC-PG29 WS	111 124 721 5012

Please refer to page 15-02 for choosing proper model of lock.

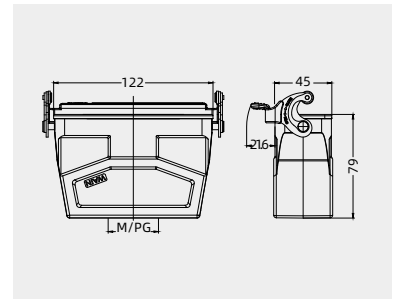

Bulkhead mounted housings



Thread	Designation	Order No.
---	W24B-BK-1L/SC	111 124 321 1001
	with plastic cover	
---	W24B-BK-1L/SC-CV	111 124 321 8001
	with metal cover	
---	W24B-BK-1L/SC-MCV	111 124 321 8002

Please refer to page 15-02 for choosing proper model of lock.

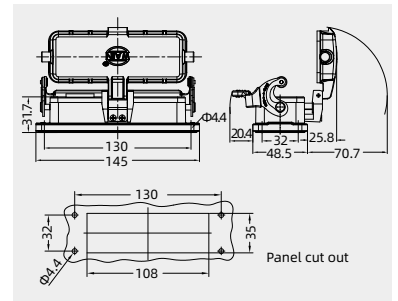

H

## 24B Metal hoods/housings

Degree of protection: IP67

## Hoods, side entry



Thread	Designation	Order No.
M25	W24B-SE-4B-M25	111 124 530 1001
M32	W24B-SE-4B-M32	111 124 530 1002
PG21	W24B-SE-4B-PG21	111 124 530 1003

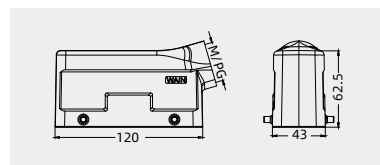

## Hoods, side entry, high construction



Thread	Designation	Order No.
---	W24B-BEH-4B	111 124 930 5003
M32	W24B-SEH-4B-M32	111 124 530 5001
M40	W24B-SEH-4B-M40	111 124 530 5002
PG21	W24B-SEH-4B-PG21	111 124 530 5003
PG29	W24B-SEH-4B-PG29	111 124 530 5004
	with sleeve	
M32	W24B-SEH-4B-M32 <a href="#">WS</a>	111 124 530 5008
PG21	W24B-SEH-4B-PG21 <a href="#">WS</a>	111 124 530 5011
PG29	W24B-SEH-4B-PG29 <a href="#">WS</a>	111 124 530 5012

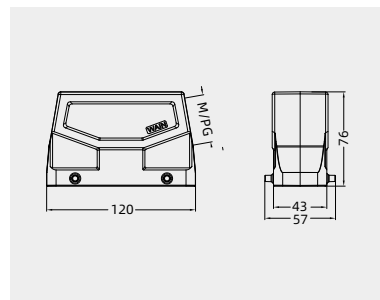

## Hoods, side entry, high construction

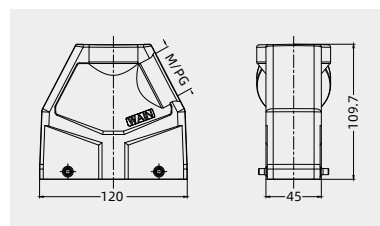

Thread	Designation	Order No.
M50	W24B-SEH-4B-M50	111 124 530 5006
PG36	W24B-SEH-4B-PG36	111 124 530 5013

Suitable for cable with maximum OD  $\Phi$ 32mm

## Hoods, top entry



Thread	Designation	Order No.
M25	W24B-TE-4B-M25	111 124 430 1001
M32	W24B-TE-4B-M32	111 124 430 1002
PG21	W24B-TE-4B-PG21	111 124 430 1003
PG29	W24B-TE-4B-PG29	111 124 430 1004

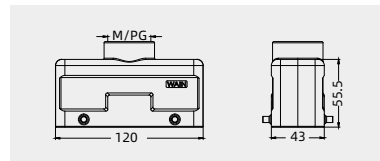

## Hoods, top entry, high construction



Thread	Designation	Order No.
---	W24B-BEH-4B	111 124 930 5003
M32	W24B-TEH-4B-M32	111 124 430 5001
M40	W24B-TEH-4B-M40	111 124 430 5002
PG21	W24B-TEH-4B-PG21	111 124 430 5003
PG29	W24B-TEH-4B-PG29	111 124 430 5004
2M32	W24B-TEH-4B-2M32	111 124 430 5005
	with sleeve	
M32	W24B-TEH-4B-M32 <a href="#">WS</a>	111 124 430 5014
PG21	W24B-TEH-4B-PG21 <a href="#">WS</a>	111 124 430 5011
PG29	W24B-TEH-4B-PG29 <a href="#">WS</a>	111 124 430 5010

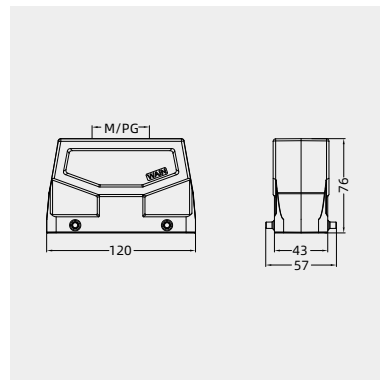

## Hoods, top entry, high construction

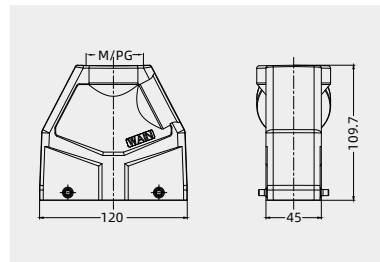

Thread	Designation	Order No.
M50	W24B-TEH-4B-M50	111 124 430 5006
PG36	W24B-TEH-4B-PG36	111 124 430 5013

Suitable for cable with maximum OD  $\Phi$ 32mm

Degree of protection: IP67

Hoods, top entry, high construction



Thread	Designation	Order No.
M50	W24B.C-TEH/E-4B-M50	111 124 430 5007

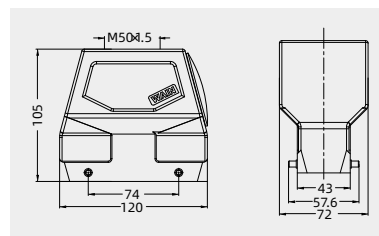

Hoods, side entry, high construction



Thread	Designation	Order No.
M50	W24B.C-SEH/E-4B-M50	111 124 530 5005

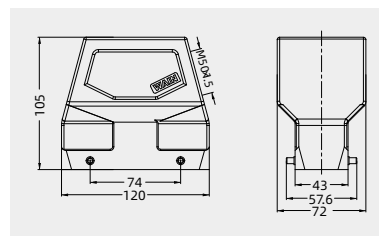

24B Metal hoods/housings

Degree of protection: IP67

Bulkhead mounted housings



Thread	Designation	Order No.
---	W24B-BK-2L/SC	111 124 341 1002

Please refer to page 15-02 for choosing proper model of lock.

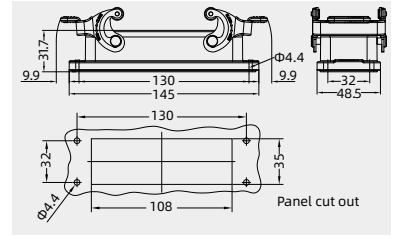

Bulkhead Mounted Housings  
(Assemble the inserts in reverse direction)



Thread	Designation	Order No.
---	W24B-RBK-2L/SC	111 124 341 1003

Please refer to page 15-02 for choosing proper model of lock.

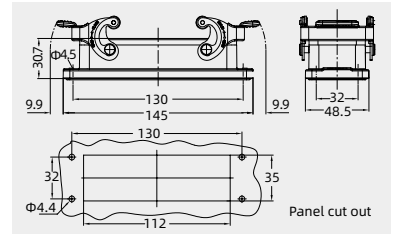

H

Housings, cable to cable



Thread	Designation	Order No.
M25	W24B-CCT-2L/SC-M25	111 124 741 1001
M32	W24B-CCT-2L/SC-M32	111 124 741 1002
PG21	W24B-CCT-2L/SC-PG21	111 124 741 1003
PG29	W24B-CCT-2L/SC-PG29	111 124 741 1004

Please refer to page 15-02 for choosing proper model of lock.

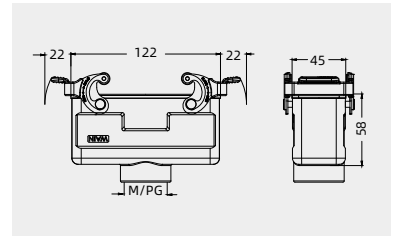

Housings, cable to cable, high construction



Thread	Designation	Order No.
M32	W24B-CCTH-2L/SC-M32	111 124 741 5002
M40	W24B-CCTH-2L/SC-M40	111 124 741 5003
PG21	W24B-CCTH-2L/SC-PG21	111 124 741 5004
PG29	W24B-CCTH-2L/SC-PG29	111 124 741 5005
	with sleeve	
M32	W24B-CCTH-2L/SC-M32 WS	111 124 741 5010
PG21	W24B-CCTH-2L/SC-PG21 WS	111 124 741 5011
PG29	W24B-CCTH-2L/SC-PG29 WS	111 124 741 5012

Please refer to page 15-02 for choosing proper model of lock.

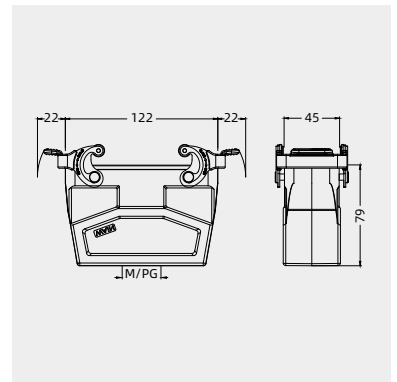

## 24B Metal hoods/housings

Degree of protection: IP67

## Hoods, side entry



Thread	Designation	Order No.
M25	W24B-SE-2L/SC-M25	111 124 541 1001
M32	W24B-SE-2L/SC-M32	111 124 541 1002
PG21	W24B-SE-2L/SC-PG21	111 124 541 1003

Please refer to page 15-02 for choosing proper model of lock.

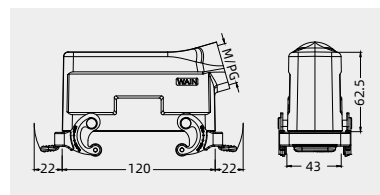

## Hoods, side entry, high construction



Thread	Designation	Order No.
M32	W24B-SEH-2L/SC-M32	111 124 541 5001
M40	W24B-SEH-2L/SC-M40	111 124 541 5002
PG21	W24B-SEH-2L/SC-PG21	111 124 541 5003
PG29	W24B-SEH-2L/SC-PG29	111 124 541 5004
M32	W24B-SEH-2L/SC-M32 WS	111 124 541 5005
PG21	W24B-SEH-2L/SC-PG21 WS	111 124 541 5011
PG29	W24B-SEH-2L/SC-PG29 WS	111 124 541 5012

Please refer to page 15-02 for choosing proper model of lock.

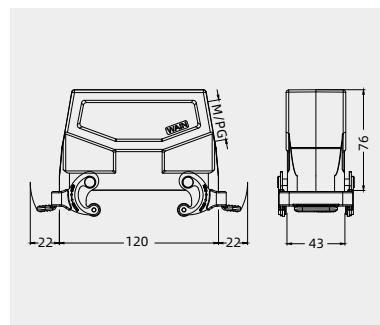

## Hoods, top entry



Thread	Designation	Order No.
M25	W24B-TE-2L/SC-M25	111 124 441 1001
M32	W24B-TE-2L/SC-M32	111 124 441 1002
PG21	W24B-TE-2L/SC-PG21	111 124 441 1003
PG29	W24B-TE-2L/SC-PG29	111 124 441 1004

Please refer to page 15-02 for choosing proper model of lock.

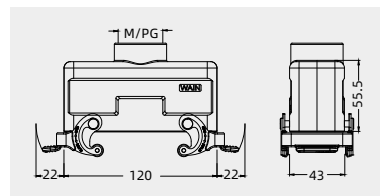

## Hoods, top entry, high construction



Thread	Designation	Order No.
M32	W24B-TEH-2L/SC-M32	111 124 441 5001
M40	W24B-TEH-2L/SC-M40	111 124 441 5002
PG21	W24B-TEH-2L/SC-PG21	111 124 441 5003
PG29	W24B-TEH-2L/SC-PG29	111 124 441 5004
M32	W24B-TEH-2L/SC-M32 WS	111 124 441 5006
PG21	W24B-TEH-2L/SC-PG21 WS	111 124 441 5011
PG29	W24B-TEH-2L/SC-PG29 WS	111 124 441 5012

Please refer to page 15-02 for choosing proper model of lock.

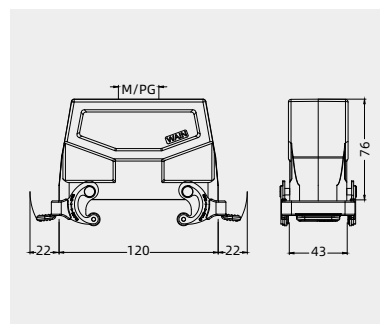

## Bulkhead mounted housings



Thread	Designation	Order No.
---	W24B-BK-4B	111 124 330 1001

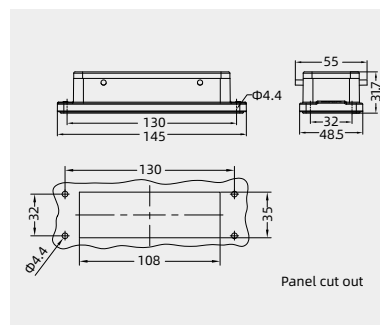

Panel cut out

## 24B Metal hoods/housings

Degree of protection: IP67

## Hoods, side entry, high construction



Thread	Designation	Order No.
M25	W24B-SEH-1L/C-M25	111 124 550 5001
M32	W24B-SEH-1L/C-M32	111 124 550 5002
M40	W24B-SEH-1L/C-M40	111 124 550 5003
PG21	W24B-SEH-1L/C-PG21	111 124 550 5004
PG29	W24B-SEH-1L/C-PG29 with sleeve	111 124 550 5005
M32	W24B-SEH-1L/C-M32 <a href="#">WS</a>	111 124 555 5004
PG21	W24B-SEH-1L/C-PG21 <a href="#">WS</a>	111 124 555 5011
PG29	W24B-SEH-1L/C-PG29 <a href="#">WS</a>	111 124 555 5012

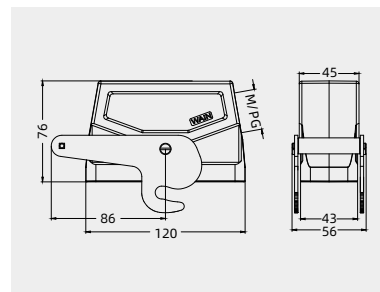

## Bulkhead mounted housings



Thread	Designation	Order No.
---	W24B-BK-2B/C	111 024 350 1001

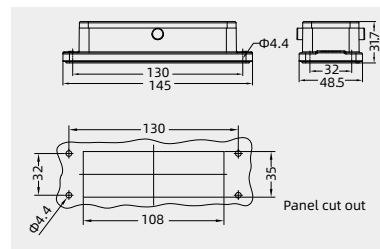

## Hoods, side entry, high construction



Thread	Designation	Order No.
M40	W24B-SEH-1L/B-M40	111 124 529 5001
PG29	W24B-SEH-1L/B-PG29 with sleeve	111 124 529 5002
M32	W24B-SEH-1L/B-M32 <a href="#">WS</a>	111 124 529 5005
PG21	W24B-SEH-1L/B-PG21 <a href="#">WS</a>	111 124 529 5004
PG29	W24B-SEH-1L/B-PG29 <a href="#">WS</a>	111 124 525 5112

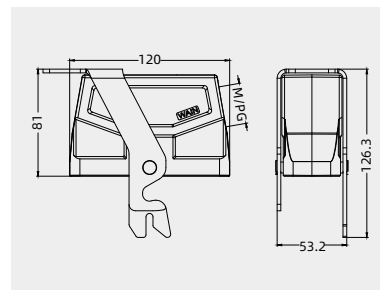

24B Metal hoods/housings  
-Suitable for harsh environment(anti-corrosion)

Degree of protection: IP67

Hoods, side entry



Thread	Designation	Order No.
M25	W24B-MSE-4B-M25	112 124 530 1001
M32	W24B-MSE-4B-M32	112 124 530 1004
PG21	W24B-MSE-4B-PG21	112 124 530 1002

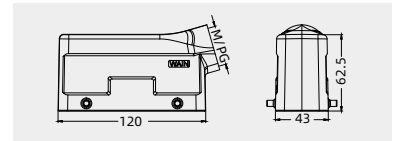

Hoods, side entry, high construction



Thread	Designation	Order No.
M32	W24B-MSEH-4B-M32	112 124 530 5005
M40	W24B-MSEH-4B-M40	112 124 530 5006
PG21	W24B-MSEH-4B-PG21	112 124 530 5011
PG29	W24B-MSEH-4B-PG29	112 124 530 5007
	with sleeve	
M32	W24B-MSEH-4B-M32 <b>WS</b>	112 124 530 5004
PG21	W24B-MSEH-4B-PG21 <b>WS</b>	112 124 530 5013
PG29	W24B-MSEH-4B-PG29 <b>WS</b>	112 124 530 5012

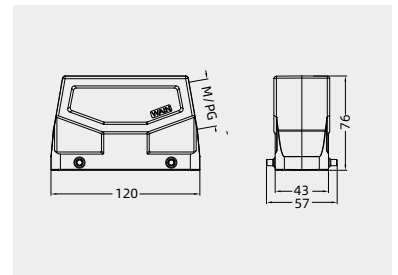

Hoods, top entry



Thread	Designation	Order No.
M25	W24B-MTE-4B-M25	112 124 530 1003
M32	W24B-MTE-4B-M32	112 124 430 1005
PG21	W24B-MTE-4B-PG21	112 124 430 1004
PG29	W24B-MTE-4B-PG29	112 124 430 1003

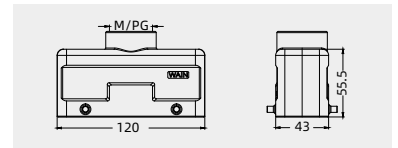

Hoods, top entry, high construction



Thread	Designation	Order No.
M32	W24B-MTEH-4B-M32	112 124 430 5006
M40	W24B-MTEH-4B-M40	112 124 430 5007
PG21	W24B-MTEH-4B-PG21	112 124 430 5011
PG29	W24B-MTEH-4B-PG29	112 124 430 5008
	with sleeve	
M32	W24B-MTEH-4B-M32 <b>WS</b>	112 124 430 5004
PG21	W24B-MTEH-4B-PG21 <b>WS</b>	112 124 430 5010
PG29	W24B-MTEH-4B-PG29 <b>WS</b>	112 124 430 5012

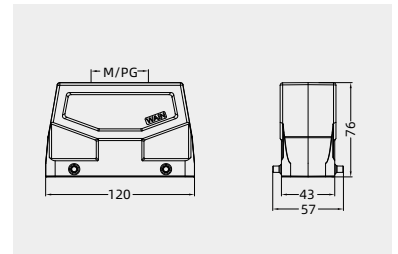

Bulkhead mounted housings



Thread	Designation	Order No.
---	W24B-MBK-2L/SC	112 124 311 1001

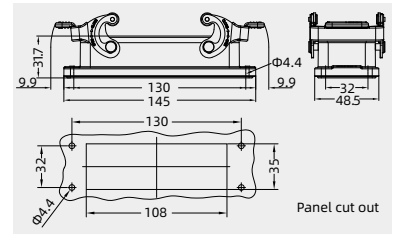

Housings, cable to cable



Thread	Designation	Order No.
M25	W24B-MCCT-2L/SC-M25	112 124 741 1003
M32	W24B-MCCT-2L/SC-M32	112 124 741 1004
PG21	W24B-MCCT-2L/SC-PG21	112 124 741 1005
PG29	W24B-MCCT-2L/SC-PG29	112 124 741 1006

Please refer to page 15-02 for choosing proper model of lock.

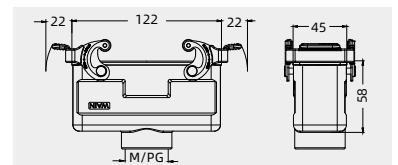

Housings, cable to cable, high construction



Thread	Designation	Order No.
M32	W24B-MCCTH-2L/SC-M32	112 124 741 5004
M40	W24B-MCCTH-2L/SC-M40	112 124 741 5005
PG21	W24B-MCCTH-2L/SC-PG21	112 124 741 5011
PG29	W24B-MCCTH-2L/SC-PG29	112 124 741 5012
	with sleeve	
M32	W24B-MCCTH-2L/SC-M32 <b>WS</b>	112 124 741 5003
PG21	W24B-MCCTH-2L/SC-PG21 <b>WS</b>	112 124 741 5001
PG29	W24B-MCCTH-2L/SC-PG29 <b>WS</b>	112 124 741 5002

Please refer to page 15-02 for choosing proper model of lock.

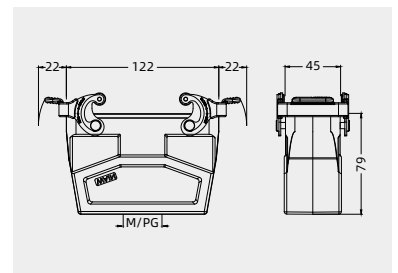

## 24B Metal hoods/housings -Suitable for harsh environment(anti-corrosion)

Degree of protection: IP67

### Hoods, side entry, high construction



Thread	Designation	Order No.
M32	W24B-MSEH-1L/C-M32	112 124 550 5006
PG21	W24B-MSEH-1L/C-PG21	112 124 555 5011
PG29	W24B-MSEH-1L/C-PG29 with sleeve	112 124 550 5007
M32	W24B-MSEH-1L/C-M32 <b>WS</b>	112 124 555 5004
PG21	W24B-MSEH-1L/C-PG21 <b>WS</b>	112 124 555 5013
PG29	W24B-MSEH-1L/C-PG29 <b>WS</b>	112 124 555 5012

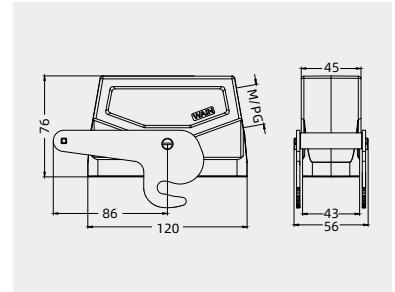

### Bulkhead mounted housings



Thread	Designation	Order No.
---	W24B-MBK-2B/C	112 124 350 1001

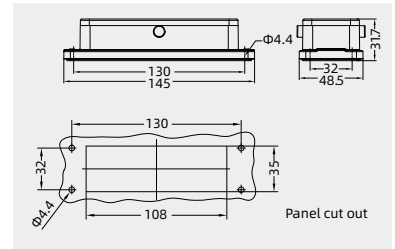



24B EMC Metal hoods/housings

Degree of protection: IP67

Hoods, side entry



Thread	Designation	Order No.
M25	EMC.W24B-SE-4B-M25	111 224 530 1001
M32	EMC.W24B-SE-4B-M32	111 224 530 1002
PG21	EMC.W24B-SE-4B-PG21	111 224 530 1003

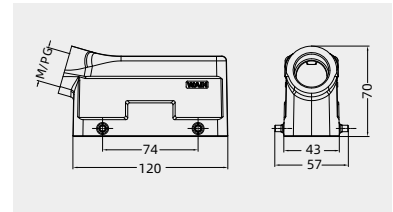

Hoods, side entry, high construction



Thread	Designation	Order No.
---	EMC.W24B-BEH-4B	111 224 930 5004
M32	EMC.W24B-SEH-4B-M32	111 224 530 5008
M40	EMC.W24B-SEH-4B-M40	111 224 530 5009
PG21	EMC.W24B-SEH-4B-PG21	111 224 530 5006
PG29	EMC.W24B-SEH-4B-PG29	111 224 530 5010
	with sleeve	
M32	EMC.W24B-SEH-4B-M32 <i>WS</i>	111 124 535 5501
PG21	EMC.W24B-SEH-4B-PG21 <i>WS</i>	111 224 535 5001
PG29	EMC.W24B-SEH-4B-PG29 <i>WS</i>	111 124 535 5013

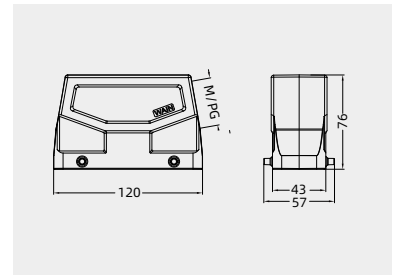

Hoods, top entry



Thread	Designation	Order No.
M25	EMC.W24B-TE-4B-M25	111 224 430 1001
M32	EMC.W24B-TE-4B-M32	111 224 430 1002
PG21	EMC.W24B-TE-4B-PG21	111 224 430 1003
PG29	EMC.W24B-TE-4B-PG29	111 224 430 1004

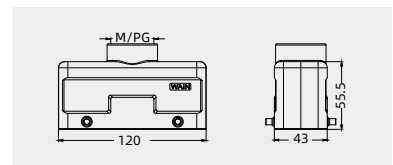

Hoods, top entry, high construction



Thread	Designation	Order No.
---	EMC.W24B-BEH-4B	111 224 930 5004
M32	EMC.W24B-TEH-4B-M32	111 224 430 5009
M40	EMC.W24B-TEH-4B-M40	111 224 430 5010
PG21	EMC.W24B-TEH-4B-PG21	111 224 430 5001
PG29	EMC.W24B-TEH-4B-PG29	111 224 430 5011
	with sleeve	
M32	EMC.W24B-TEH-4B-M32 <i>WS</i>	111 124 435 5501
PG21	EMC.W24B-TEH-4B-PG21 <i>WS</i>	111 124 435 5502
PG29	EMC.W24B-TEH-4B-PG29 <i>WS</i>	111 124 435 5015

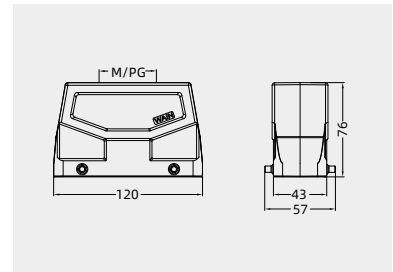

Bulkhead mounted housings



Thread	Designation	Order No.
---	EMC1.W24B-BK-2L/SC	111 124 341 1001

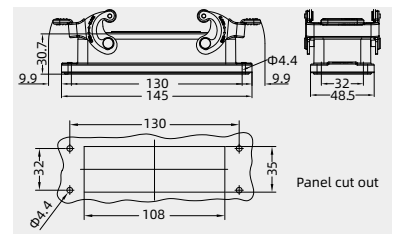

Please refer to page 15-02 for choosing proper model of lock.

24B Pressure tight hoods/housings

Degree of protection: IP67

W version

Hoods, side entry, high construction



Thread	Designation	Order No.
M25	HP24B-SEH-2S-M25	115 024 520 5103
M32	HP24B-SEH-2S-M32	115 024 520 5104
M40	HP24B-SEH-2S-M40	115 024 520 5105
PG21	HP24B-SEH-2S-PG21	115 024 520 5111
PG29	HP24B-SEH-2S-PG29	115 024 520 5112

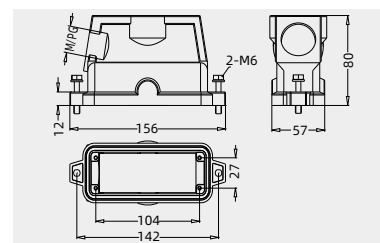

Hoods, top entry, high construction



Thread	Designation	Order No.
M25	HP24B-TEH-2S-M25	115 024 420 5103
M32	HP24B-TEH-2S-M32	115 024 420 5104
M40	HP24B-TEH-2S-M40	115 024 420 5105
M50	HP24B-TEH-2S-M50	115 024 420 5106
PG21	HP24B-TEH-2S-PG21	115 024 420 5111
PG29	HP24B-TEH-2S-PG29	115 024 420 5112
PG36	HP24B-TEH-2S-PG36	115 024 420 5113

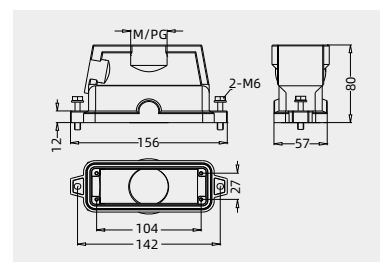

Surface mounted housings, high construction



Thread	Designation	Order No.
M25	HP24B-SFH-2H-M25	115 024 220 5003
M32	HP24B-SFH-2H-M32	115 024 220 5004
M40	HP24B-SFH-2H-M40	115 024 220 5005
PG21	HP24B-SFH-2H-PG21	115 024 220 5011
PG29	HP24B-SFH-2H-PG29	115 024 220 5012

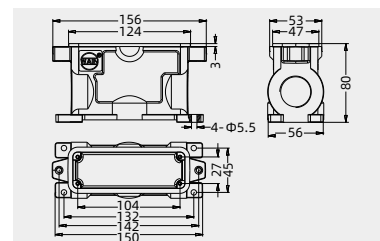

Bulkhead mounted housings



Thread	Designation	Order No.
---	HP24B-BK-2H	115 024 320 1001

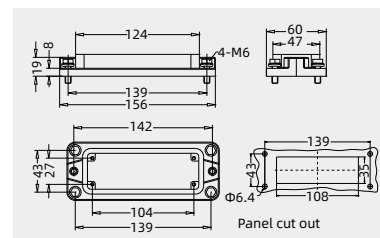

Bulkhead mounted housings



Thread	Designation	Order No.
---	HP24B-BK/S-2H	115 024 320 1101

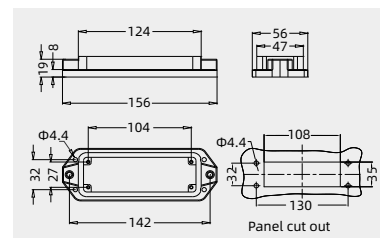

Protection covers, plastic



Connect way	Designation	Order No.
---	HP24B-CV-2S/2	115 024 020 8002

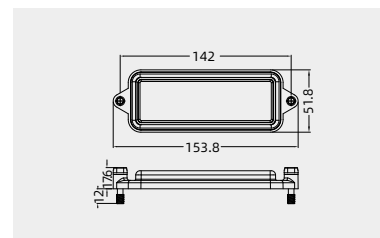

## 24B Pressure tight hoods/housings

Degree of protection: IP68/IP69K

W version

Protection covers, plastic,  
for hoods



Connect way	Designation	Order No.
---	HP24B-CV-2H/1	115 024 020 8500

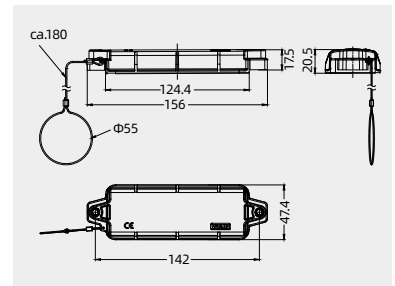

## 24B Pressure tight hoods/housings

Degree of protection: IP68/IP69K

W version

Hoods, side entry, high construction



Thread	Designation	Order No.
M50	HP24B-SEHH-2S-M50	115 024 520 5106

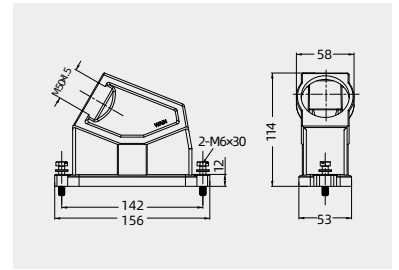

## 24B Pressure tight hoods/housings

Degree of protection: IP68/IP69K

H version

### Hoods, side entry, high construction



Thread	Designation	Order No.
	Screw locking	
M25	HP24B/H-SEH-2S-M25	113 624 520 5003
M32	HP24B/H-SEH-2S-M32	113 624 520 5004
M40	HP24B/H-SEH-2S-M40	113 624 520 5005
M50	HP24B/H-SEH-2S-M50	113 624 520 5006
PG21	HP24B/H-SEH-2S-PG21	113 624 520 5011
PG29	HP24B/H-SEH-2S-PG29	113 624 520 5012
PG36	HP24B/H-SEH-2S-PG36	113 624 520 5013
	Toggle locking	
M25	HP24B/H-SEH-2T-M25	113 624 540 5003
M32	HP24B/H-SEH-2T-M32	113 624 540 5004
M40	HP24B/H-SEH-2T-M40	113 624 540 5005
M50	HP24B/H-SEH-2T-M50	113 624 540 5006
PG21	HP24B/H-SEH-2T-PG21	113 624 540 5011
PG29	HP24B/H-SEH-2T-PG29	113 624 540 5012
PG36	HP24B/H-SEH-2T-PG36	113 624 540 5013

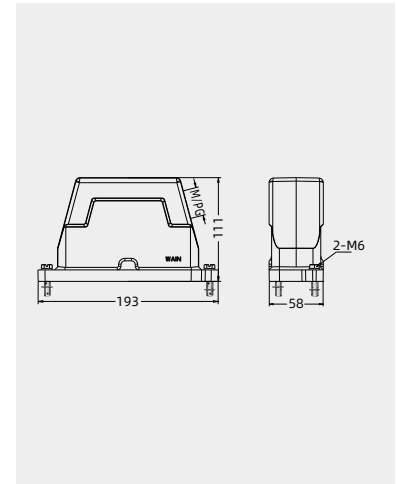

### Hoods, top entry, high construction



Thread	Designation	Order No.
	Screw locking	
M25	HP24B/H-TEH-2S-M25	113 624 420 5003
M32	HP24B/H-TEH-2S-M32	113 624 420 5004
M40	HP24B/H-TEH-2S-M40	113 624 420 5005
M50	HP24B/H-TEH-2S-M50	113 624 420 5006
PG21	HP24B/H-TEH-2S-PG21	113 624 420 5011
PG29	HP24B/H-TEH-2S-PG29	113 624 420 5012
PG36	HP24B/H-TEH-2S-PG36	113 624 420 5013
	Toggle locking	
M25	HP24B/H-TEH-2T-M25	113 624 440 5003
M32	HP24B/H-TEH-2T-M32	113 624 440 5004
M40	HP24B/H-TEH-2T-M40	113 624 440 5005
M50	HP24B/H-TEH-2T-M50	113 624 440 5006
PG21	HP24B/H-TEH-2T-PG21	113 624 440 5011
PG29	HP24B/H-TEH-2T-PG29	113 624 440 5012
PG36	HP24B/H-TEH-2T-PG36	113 624 440 5013

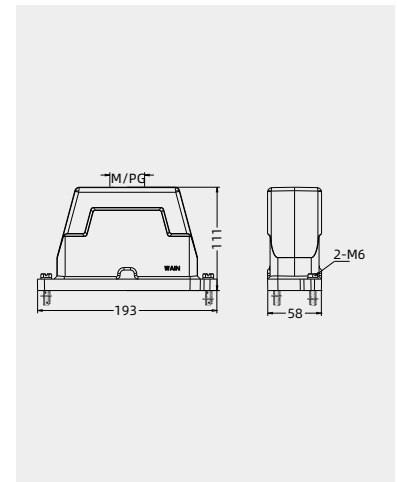

### Hoods, top entry, high construction



Thread	Designation	Order No.
	Screw locking	
M63	HP24B/H-TEH-2S-M63	113 624 420 5007
	Toggle locking	
M63	HP24B/H-TEH-2T-M63	113 624 440 5007

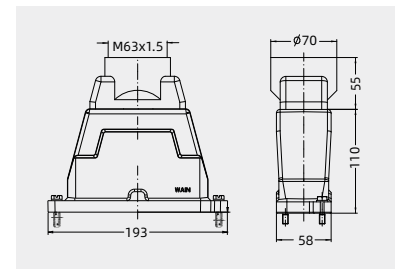

### Bulkhead mounted housings



Thread	Designation	Order No.
	Screw locking	
---	HP24B/H-BK-2H	113 624 320 1001
	Toggle locking	
---	HP24B/H-BK-2T	113 624 340 1001
	with metal cover	
	Screw locking	
---	HP24B/H-BK-2H-MCV	113 624 360 1001
	Toggle locking	
---	HP24B/H-BK-2T-MCV	113 624 370 1001

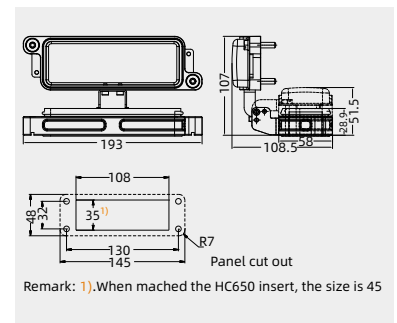

24B Pressure tight hoods/housings

Degree of protection: IP68/IP69K

H version

Hoods, side entry, high construction



Thread	Designation	Order No.
M40	HP24B/H-SEH-2S-1L/C-M40	113 624 520 5509

Other outlet hole threads available

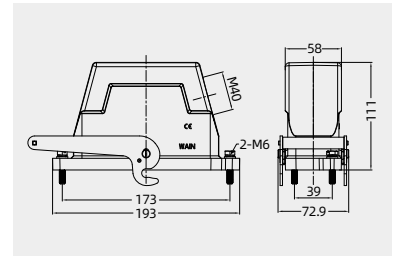

Bulkhead mounted housings



Thread	Designation	Order No.
---	HP24B/H-BK-2H-2B/C	113 624 320 1500

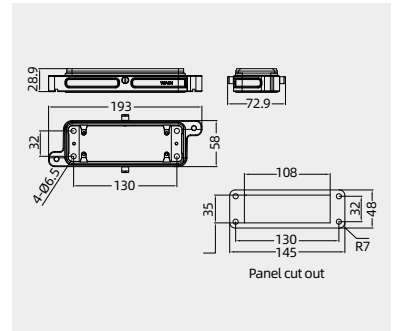

H

24B Pressure tight hoods/housings

Degree of protection: IP68/IP69K

H version

Surface mounted housings, high construction



Thread	Designation	Order No.
	Screw locking	
M25	HP24B/H-SFH-2H-M25	113 624 220 5003
M32	HP24B/H-SFH-2H-M32	113 624 220 5004
M40	HP24B/H-SFH-2H-M40	113 624 220 5005
2M40	HP24B/H-SFH-2H-2M40	113 624 220 5025
PG21	HP24B/H-SFH-2H-PG21	113 624 220 5011
PG29	HP24B/H-SFH-2H-PG29	113 624 220 5012
PG36	HP24B/H-SFH-2H-PG36	113 624 220 5013
	Toggle locking	
M25	HP24B/H-SFH-2T-M25	113 624 240 5003
M32	HP24B/H-SFH-2T-M32	113 624 240 5004
M40	HP24B/H-SFH-2T-M40	113 624 240 5005
2M40	HP24B/H-SFH-2T-2M40	113 624 240 5025
PG21	HP24B/H-SFH-2T-PG21	113 624 240 5011
PG29	HP24B/H-SFH-2T-PG29	113 624 240 5012
PG36	HP24B/H-SFH-2T-PG36	113 624 240 5013

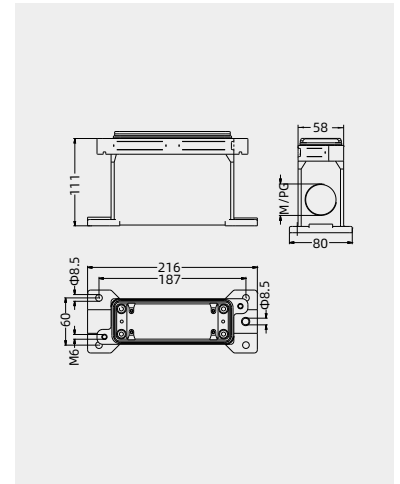

Surface mounted housings



Thread	Designation	Order No.
	Screw locking	
3M25	HP24B/H-BK-SE-2H-3M25	113 624 920 1036
	Toggle locking	
3M25	HP24B/H-BK-SE-2T-3M25	113 624 940 1036

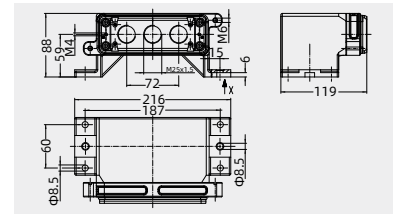

Protection covers,for housings



Connect way	Designation	Order No.
	Screw locking	
	HP24B/H-MCV-2S	113 624 020 8101
	Toggle locking	
	HP24B/H-MCV-2T	113 624 040 8103

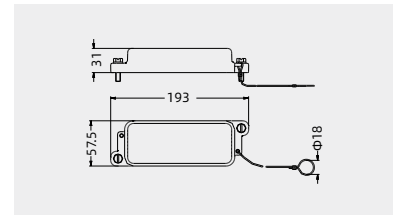

Protection covers,for hoods



Connect way	Designation	Order No.
	Screw locking	
	HP24B/H-MCV-2H/1	113 624 020 8111
	Toggle locking	
	HP24B/H-MCV-2T/1	113 624 040 8101

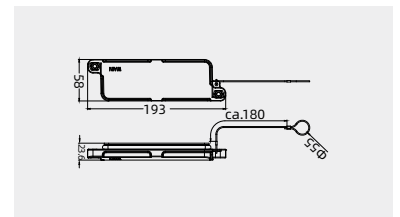

Protection covers, for housings(IP5X)



Connect way	Designation	Order No.
---	HP24B/H-CV/C	113 024 900 8001

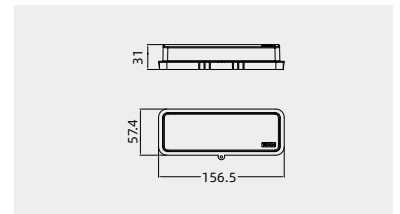

## 24B Pressure tight hoods/housings

Degree of protection: IP68/IP69K

The following hoods/housings comply with the standards for rail transport industry in China.

H version

## Hoods, side entry, high construction



Thread	Designation	Order No.
M25	HP24B/H-SEH-4S-M25	113 624 530 5003
M32	HP24B/H-SEH-4S-M32	113 624 530 5004
M40	HP24B/H-SEH-4S-M40	113 624 530 5005
PG21	HP24B/H-SEH-4S-PG21	113 624 530 5011
PG29	HP24B/H-SEH-4S-PG29	113 624 530 5012

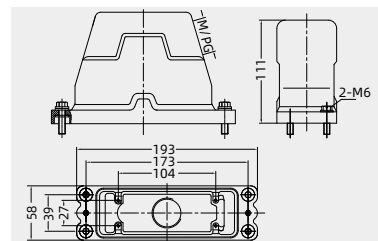

## Hoods, top entry, high construction



Thread	Designation	Order No.
M25	HP24B/H-TEH-4S-M25	113 624 430 5003
M32	HP24B/H-TEH-4S-M32	113 624 430 5004
M40	HP24B/H-TEH-4S-M40	113 624 430 5005
M50	HP24B/H-TEH-4S-M50	113 624 430 5006
PG21	HP24B/H-TEH-4S-PG21	113 624 430 5011
PG29	HP24B/H-TEH-4S-PG29	113 624 430 5012
PG36	HP24B/H-TEH-4S-PG36	113 624 430 5013

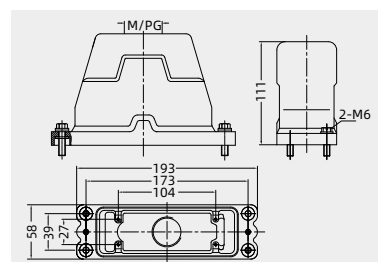

## Hoods, top entry, high construction



Thread	Designation	Order No.
3M32	HP24B/H-TEHH-4S-3M32	113 624 430 5037

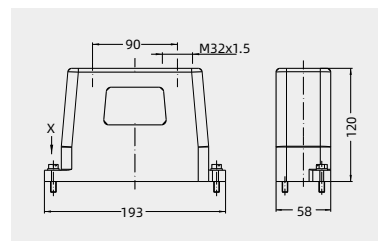

## Hoods, top entry, high construction



Thread	Designation	Order No.
M63	HP24B/H-TEH-4S-M63	113 624 430 5007

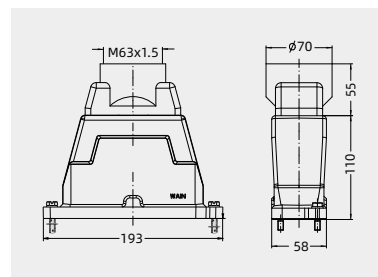

## Bulkhead mounted housings



Connect way	Designation	Order No.
---	HP24B/H-BK-4H	113 624 330 1001

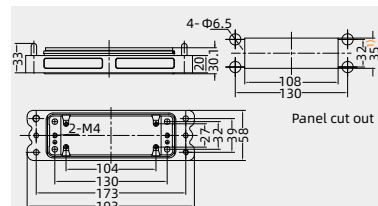

Remark: 1) When matched the HC650 insert, the size is 45



## 24B Pressure tight hoods/housings

Degree of protection: IP68/IP69K

## Hoods, side entry, high construction



Thread	Designation	Order No.
M32	HC24B-SEH-2S-M32	114 024 520 5004
M40	HC24B-SEH-2S-M40	114 024 520 5005
PG21	HC24B-SEH-2S-PG21	114 024 520 5011
PG29	HC24B-SEH-2S-PG29	114 024 520 5012

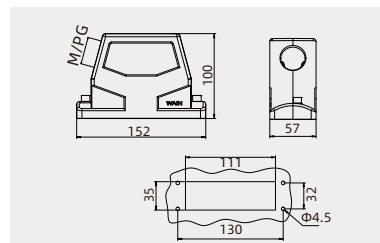

## Hoods, side entry, high construction



Thread	Designation	Order No.
M32	HC24B-SEHH-2S-M32	130 024 520 1003
M40	HC24B-SEHH-2S-M40	130 024 520 1005
M50	HC24B-SEHH-2S-M50	130 024 520 1001
PG21	HC24B-SEHH-2S-PG21	130 024 520 1007
PG29	HC24B-SEHH-2S-PG29	130 024 520 1009

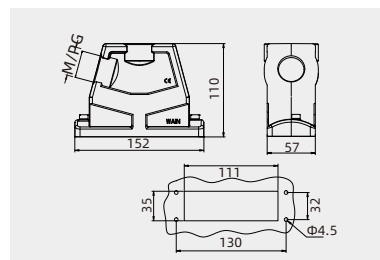

## Hoods, top entry, high construction



Thread	Designation	Order No.
M32	HC24B-TEH-2S-M32	114 024 420 5004
M40	HC24B-TEH-2S-M40	114 024 420 5005
PG21	HC24B-TEH-2S-PG21	114 024 420 5011
PG29	HC24B-TEH-2S-PG29	114 024 420 5012

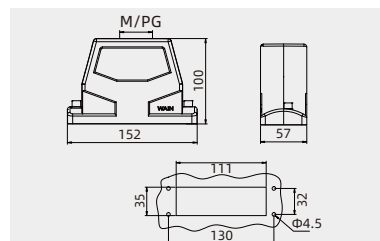

## Hoods, top entry, high construction



Thread	Designation	Order No.
M32	HC24B-TEHH-2S-M32	130 024 420 1003
M40	HC24B-TEHH-2S-M40	130 024 420 1005
M50	HC24B-TEHH-2S-M50	130 024 420 1001
PG21	HC24B-TEHH-2S-PG21	130 024 420 1007
PG29	HC24B-TEHH-2S-PG29	130 024 420 1009

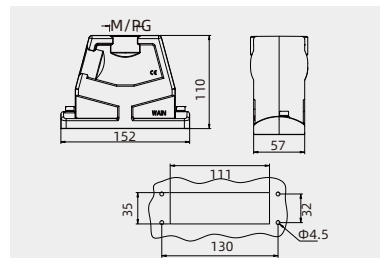

## Mounting flange



Applications	Designation	Order No.
for integral type hoods	APT-C	114 000 000 1001

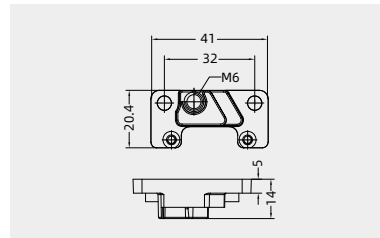

## Protection covers, plastic

Degree of protection: IP65



Thread	Designation	Order No.
---	HC24B-CV-2S/2	130 024 020 8001

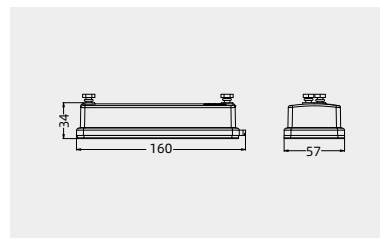

## 24B Pressure tight hoods/housings

Degree of protection: IP68/IP69K

EMC Pressure tight hoods/housings

## Hoods, top entry, high construction



Thread	Designation	Order No.
M25	EMC.W24B-TEH-4S-M32	111 124 430 5012
M32	EMC.W24B-TEH-4S-M40	111 224 430 1005
PG21	EMC.W24B-TEH-4S-PG21	111 224 430 1006
PG29	EMC.W24B-TEH-4S-PG29	111 224 430 1007

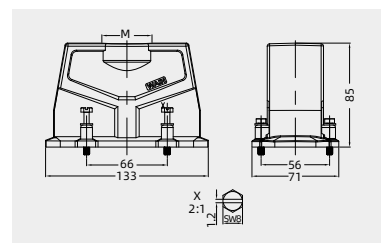

## Hoods, side entry, high construction



Thread	Designation	Order No.
M25	EMC.W24B-SEH-4S-M32	111 224 530 5002
M32	EMC.W24B-SEH-4S-M40	111 224 530 5003
PG21	EMC.W24B-SEH-4S-PG21	111 224 530 5004
PG29	EMC.W24B-SEH-4S-PG29	111 224 530 5005

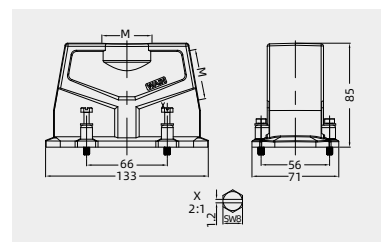

## Bulkhead mounted housings



Thread	Designation	Order No.
---	EMC.W24B-BK-4H	111 224 330 1001

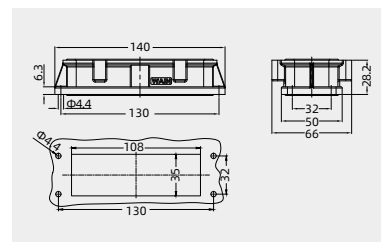

## 24B Metal hoods/housings - for high voltage inserts(HVE Series)

Degree of protection: IP65

### Hoods, side entry



Thread	Designation	Order No.
M25	HV24B-SE-2B-M25	124 024 515 1003
M32	HV24B-SE-2B-M32	124 024 515 1004
PG21	HV24B-SE-2B-PG21	124 024 515 1011

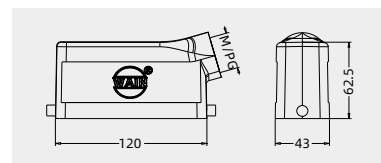

### Hoods, side entry, high construction



Thread	Designation	Order No.
M32	WV24B-SEH-2B-M32	124 124 510 5001
M40	WV24B-SEH-2B-M40	124 124 510 5002
PG21	WV24B-SEH-2B-PG21	124 124 510 5003
PG29	WV24B-SEH-2B-PG29	124 124 510 5004
M32	WV24B-SEH-2B-M32 WS	124 124 515 5004
PG21	WV24B-SEH-2B-PG21 WS	124 124 515 5011
PG29	WV24B-SEH-2B-PG29 WS	124 124 515 5012

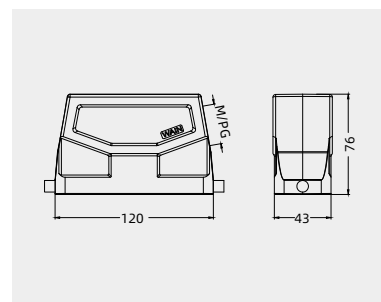

### Hoods, top entry



Thread	Designation	Order No.
M25	HV24B-TE-2B-M25	124 024 415 1003
M32	HV24B-TE-2B-M32	124 024 415 1004
PG21	HV24B-TE-2B-PG21	124 024 415 1011

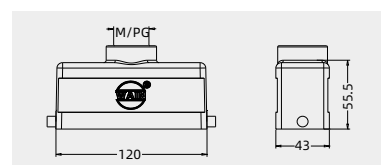

### Hoods, top entry, high construction



Thread	Designation	Order No.
M32	WV24B-TEH-2B-M32	124 124 410 5001
M40	WV24B-TEH-2B-M40	124 124 410 5002
PG21	WV24B-TEH-2B-PG21	124 124 410 5003
PG29	WV24B-TEH-2B-PG29	124 124 410 5004
M32	WV24B-TEH-2B-M32 WS	124 124 415 5004
PG21	WV24B-TEH-2B-PG21 WS	124 124 415 5011
PG29	WV24B-TEH-2B-PG29 WS	124 124 415 5012

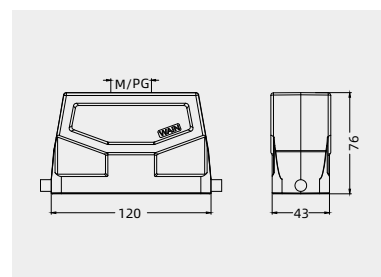

### Housings, cable to cable



Thread	Designation	Order No.
M25	HV24B-CCT-1L/SC-M25	124 024 721 1003
PG21	HV24B-CCT-1L/SC-PG21	124 024 721 1011

Please refer to page 15-02 for choosing proper model of lock.

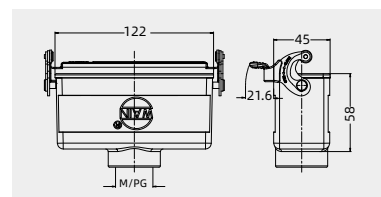

### Housings, cable to cable, high construction



Thread	Designation	Order No.
M32	WV24B-CCTH-1L/SC-M32	124 124 721 5001
M40	WV24B-CCTH-1L/SC-M40	124 124 721 5002
PG21	WV24B-CCTH-1L/SC-PG21	124 124 721 5003
PG29	WV24B-CCTH-1L/SC-PG29	124 124 721 5004
M32	WV24B-CCTH-1L/SC-M32 WS	124 124 721 5005
PG21	WV24B-CCTH-1L/SC-PG21 WS	124 124 721 5011
PG29	WV24B-CCTH-1L/SC-PG29 WS	124 124 721 5012

Please refer to page 15-02 for choosing proper model of lock.

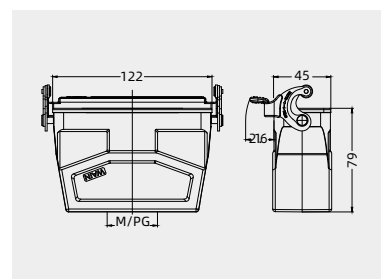

## 24B Metal hoods/housings - for high voltage inserts(HVE Series)

Degree of protection: IP65

### Bulkhead mounted housings



Thread	Designation	Order No.
---	HV24B-BK-1L/SC	124 024 321 1001
with plastic cover		
---	HV24B-BK-1L/SC-CV	124 024 361 1001
with metal cover		
---	HV24B-BK-1L/SC-MCV	124 024 361 1101

Please refer to page 15-02 for choosing proper model of lock.

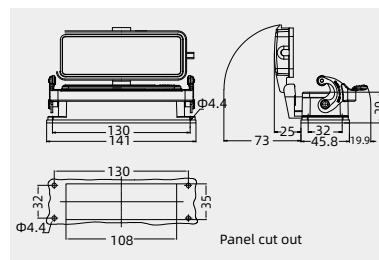

### Surface mounted housings



Thread	Designation	Order No.
M25	HV24B-SF-1L/SC-M25	124 024 221 1003
2M25	HV24B-SF-1L/SC-2M25	124 024 221 1023
PG21	HV24B-SF-1L/SC-PG21	124 024 221 1011
2PG21	HV24B-SF-1L/SC-2PG21	124 024 221 1031
with plastic cover		
M25	HV24B-SF-1L/SC-CV-M25	124 024 261 1003
2M25	HV24B-SF-1L/SC-CV-2M25	124 024 261 1023
PG21	HV24B-SF-1L/SC-CV-PG21	124 024 261 1011
2PG21	HV24B-SF-1L/SC-CV-2PG21	124 024 261 1031
with metal cover		
M25	HV24B-SF-1L/SC-MCV-M25	124 024 261 1103
2M25	HV24B-SF-1L/SC-MCV-2M25	124 024 261 1123
PG21	HV24B-SF-1L/SC-MCV-PG21	124 024 261 1111
2PG21	HV24B-SF-1L/SC-MCV-2PG21	124 024 261 1131

Please refer to page 15-02 for choosing proper model of lock.

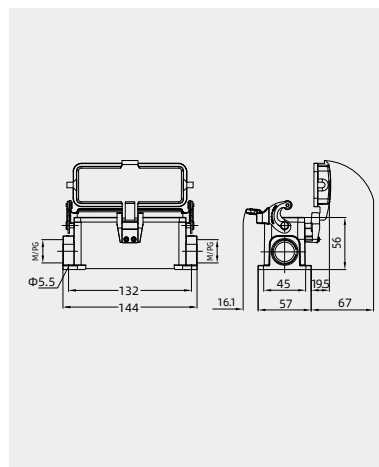

### Surface mounted housings, high construction



Thread	Designation	Order No.
M32	HV24B-SFH-1L/SC-M32	124 024 221 5004
2M32	HV24B-SFH-1L/SC-2M32	124 024 221 5024
PG21	HV24B-SFH-1L/SC-PG21	124 024 221 5011
2PG21	HV24B-SFH-1L/SC-2PG21	124 024 221 5031
PG29	HV24B-SFH-1L/SC-PG29	124 024 221 5012
2PG29	HV24B-SFH-1L/SC-2PG29	124 024 221 5032
with plastic cover		
M32	HV24B-SFH-1L/SC-CV-M32	124 024 261 5004
2M32	HV24B-SFH-1L/SC-CV-2M32	124 024 261 5024
PG21	HV24B-SFH-1L/SC-CV-PG21	124 024 261 5011
2PG21	HV24B-SFH-1L/SC-CV-2PG21	124 024 261 5031
PG29	HV24B-SFH-1L/SC-CV-PG29	124 024 261 5012
2PG29	HV24B-SFH-1L/SC-CV-2PG29	124 024 261 5032
with metal cover		
M32	HV24B-SFH-1L/SC-MCV-M32	124 024 261 5104
2M32	HV24B-SFH-1L/SC-MCV-2M32	124 024 261 5124
PG21	HV24B-SFH-1L/SC-MCV-PG21	124 024 261 5111
2PG21	HV24B-SFH-1L/SC-MCV-2PG21	124 024 261 5131
PG29	HV24B-SFH-1L/SC-MCV-PG29	124 024 261 5112
2PG29	HV24B-SFH-1L/SC-MCV-2PG29	124 024 261 5132

Please refer to page 15-02 for choosing proper model of lock.

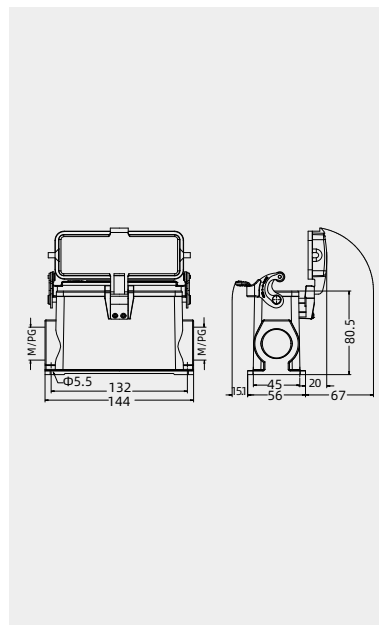

## 24B Metal hoods/housings - for high voltage inserts(HVE Series)

Degree of protection: IP65

### Hoods, side entry



Thread	Designation	Order No.
M25	HV24B-SE-4B-M25	124 024 530 1003
M32	HV24B-SE-4B-M32	124 024 530 1004
PG21	HV24B-SE-4B-PG21	124 024 530 1011

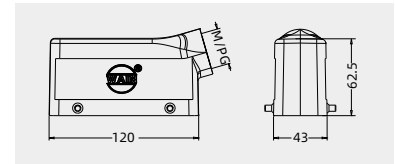

### Hoods, side entry, high construction



Thread	Designation	Order No.
M32	WV24B-SEH-4B-M32	124 124 530 5001
M40	WV24B-SEH-4B-M40	124 124 530 5002
PG21	WV24B-SEH-4B-PG21	124 124 530 5003
PG29	WV24B-SEH-4B-PG29 with sleeve	124 124 530 5004
M32	WV24B-SEH-4B-M32 <a href="#">WS</a>	124 124 530 5007
PG21	WV24B-SEH-4B-PG21 <a href="#">WS</a>	124 124 530 5011
PG29	WV24B-SEH-4B-PG29 <a href="#">WS</a>	124 124 530 5012

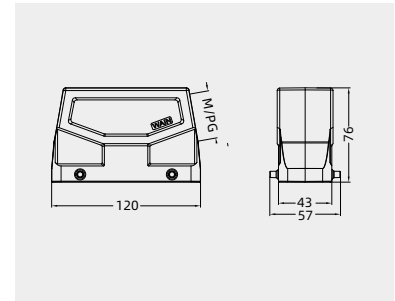

### Hoods, top entry



Thread	Designation	Order No.
M25	HV24B-TE-4B-M25	124 024 430 1003
M32	HV24B-TE-4B-M32	124 024 430 1004
PG21	HV24B-TE-4B-PG21	124 024 430 1011

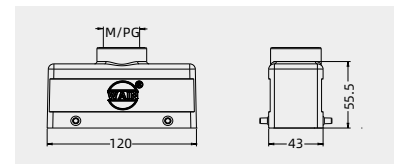

### Hoods, top entry, high construction



Thread	Designation	Order No.
M32	WV24B-TEH-4B-M32	124 124 430 5001
M40	WV24B-TEH-4B-M40	124 124 430 5002
PG21	WV24B-TEH-4B-PG21	124 124 430 5003
PG29	WV24B-TEH-4B-PG29 with sleeve	124 124 430 5004
M32	WV24B-TEH-4B-M32 <a href="#">WS</a>	124 124 430 5008
PG21	WV24B-TEH-4B-PG21 <a href="#">WS</a>	124 124 430 5011
PG29	WV24B-TEH-4B-PG29 <a href="#">WS</a>	124 124 430 5012

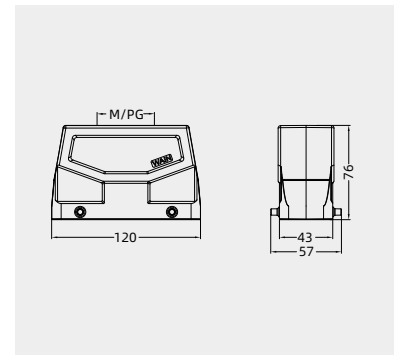

## 24B Metal hoods/housings - for high voltage inserts(HVE Series)

Degree of protection: IP65

### Bulkhead mounted housings



Thread	Designation	Order No.
---	HV24B-BK-2L/SC	124 024 341 1001

Please refer to page 15-02 for choosing proper model of lock.

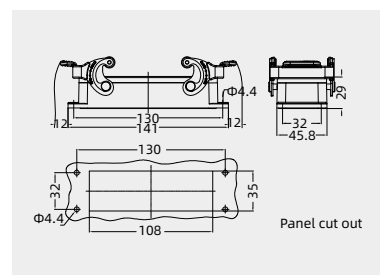

### Surface mounted housings



Thread	Designation	Order No.
M25	HV24B-SF-2L/SC-M25	124 024 241 1003
2M25	HV24B-SF-2L/SC-2M25	124 024 241 1023
PG21	HV24B-SF-2L/SC-PG21	124 024 241 1011
2PG21	HV24B-SF-2L/SC-2PG21	124 024 241 1031

Please refer to page 15-02 for choosing proper model of lock.

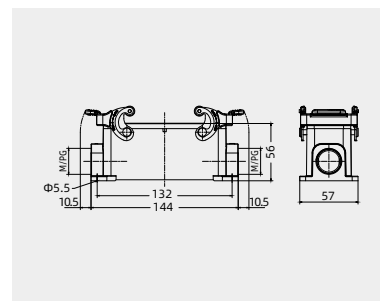

### Surface mounted housings, high construction



Thread	Designation	Order No.
M32	HV24B-SFH-2L/SC-M32	124 024 241 5004
2M32	HV24B-SFH-2L/SC-2M32	124 024 241 5024
PG21	HV24B-SFH-2L/SC-PG21	124 024 241 5011
2PG21	HV24B-SFH-2L/SC-2PG21	124 024 241 5031
PG29	HV24B-SFH-2L/SC-PG29	124 024 241 5012
2PG29	HV24B-SFH-2L/SC-2PG29	124 024 241 5032

Please refer to page 15-02 for choosing proper model of lock.

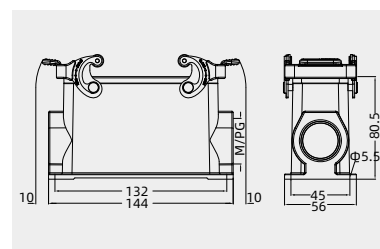

### Housings, cable to cable



Thread	Designation	Order No.
M25	HV24B-CCT-2L/SC-M25	124 024 741 1003
PG21	HV24B-CCT-2L/SC-PG21	124 024 741 1011

Please refer to page 15-02 for choosing proper model of lock.

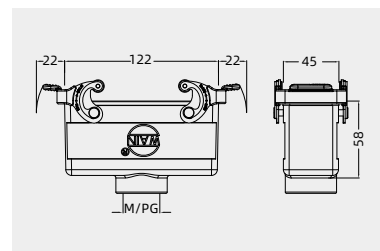

## 24B Metal hoods/housings - for high voltage inserts(HVE Series)

Degree of protection: IP65

Housings, cable to cable, high construction



Thread	Designation	Order No.
M32	WV24B-CCTH-2L/SC-M32	124 124 741 5001
M40	WV24B-CCTH-2L/SC-M40	124 124 741 5002
PG21	WV24B-CCTH-2L/SC-PG21	124 124 741 5003
PG29	WV24B-CCTH-2L/SC-PG29	124 124 741 5004
	with sleeve	
M32	WV24B-CCTH-2L/SC-M32 WS	124 124 741 5005
PG21	WV24B-CCTH-2L/SC-PG21 WS	124 124 741 5011
PG29	WV24B-CCTH-2L/SC-PG29 WS	124 124 741 5012

Please refer to page 15-02 for choosing proper model of lock.

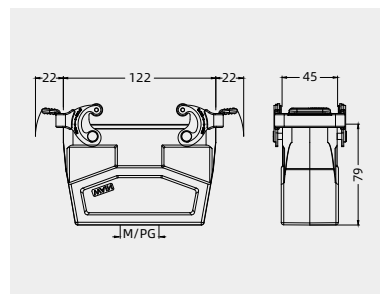

Protection covers, plastic



Connect way	Applications	Designation	Order No.
---	for hoods	H24B-CV-4C	111 024 090 8009

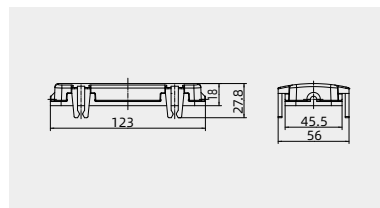

Protection covers, plastic



Connect way	Applications	Designation	Order No.
	for Housings, cable to cable	H24B-CV-4B/1	111 024 030 8001
	for Housings, bulkhead mounting / surface mounting	H24B-CV-4B/2	111 024 030 8002

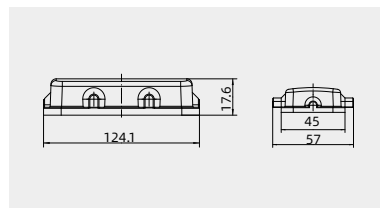

## 24B Metal hoods/housings - for high voltage inserts(HVE Series)

Degree of protection: IP65

### Hoods, side entry



Thread	Designation	Order No.
M25	HV24B-SE-2L/SC-M25	124 024 541 1003
M32	HV24B-SE-2L/SC-M32	124 024 541 1004
PG21	HV24B-SE-2L/SC-PG21	124 024 541 1011

Please refer to page 15-02 for choosing proper model of lock.

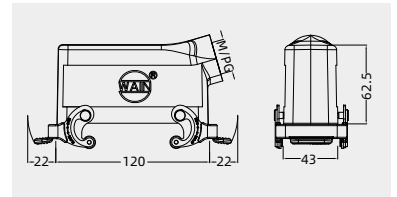

### Hoods, side entry, high construction



Thread	Designation	Order No.
M32	WV24B-SEH-2L/SC-M32	124 124 541 5001
M40	WV24B-SEH-2L/SC-M40	124 124 541 5002
PG21	WV24B-SEH-2L/SC-PG21	124 124 541 5003
PG29	WV24B-SEH-2L/SC-PG29	124 124 541 5004
	with sleeve	
M32	WV24B-SEH-2L/SC-M32 WS	124 124 541 5005
PG21	WV24B-SEH-2L/SC-PG21 WS	124 124 541 5011
PG29	WV24B-SEH-2L/SC-PG29 WS	124 124 541 5012

Please refer to page 15-02 for choosing proper model of lock.

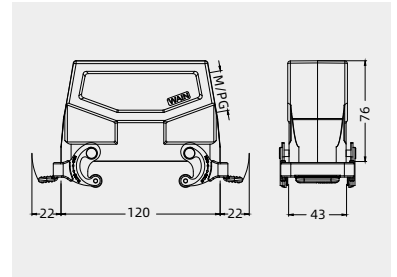

### Hoods, top entry



Thread	Designation	Order No.
M25	HV24B-TE-2L/SC-M25	124 024 441 1003
PG21	HV24B-TE-2L/SC-PG21	124 024 441 1011

Please refer to page 15-02 for choosing proper model of lock.

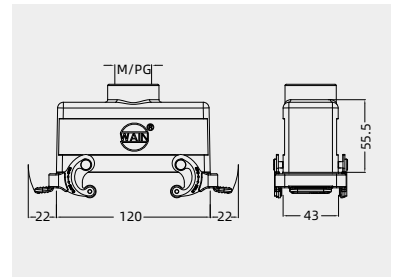

### Hoods, top entry, high construction



Thread	Designation	Order No.
M32	WV24B-TEH-2L/SC-M32	124 124 441 5001
M40	WV24B-TEH-2L/SC-M40	124 124 441 5002
PG21	WV24B-TEH-2L/SC-PG21	124 124 441 5003
PG29	WV24B-TEH-2L/SC-PG29	124 124 441 5004
	with sleeve	
M32	WV24B-TEH-2L/SC-M32 WS	124 124 441 5005
PG21	WV24B-TEH-2L/SC-PG21 WS	124 124 441 5011
PG29	WV24B-TEH-2L/SC-PG29 WS	124 124 441 5012

Please refer to page 15-02 for choosing proper model of lock.

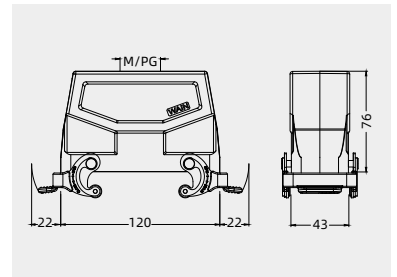

### Bulkhead mounted housings



Thread	Designation	Order No.
---	HV24B-BK-4B	124 024 330 1001
	with plastic cover	
---	HV24B-BK-4B-CV	124 024 370 1001
	with metal cover	
---	HV24B-BK-4B-MCV	124 024 370 1101

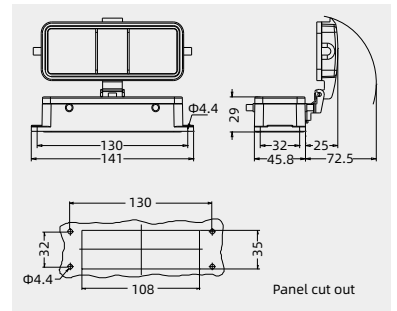



## 24B Metal hoods/housings - for high voltage inserts(HVE Series)

Degree of protection: IP65

### Surface mounted housings



Thread	Designation	Order No.
M25	HV24B-SF-4B-M25	124 024 230 1003
2M25	HV24B-SF-4B-2M25	124 024 230 1023
PG21	HV24B-SF-4B-PG21	124 024 230 1011
2PG21	HV24B-SF-4B-2PG21	124 024 230 1031
with plastic cover		
M25	HV24B-SF-4B-CV-M25	124 024 270 1003
2M25	HV24B-SF-4B-CV-2M25	124 024 270 1023
PG21	HV24B-SF-4B-CV-PG21	124 024 270 1011
2PG21	HV24B-SF-4B-CV-2PG21	124 024 270 1031
with metal cover		
M25	HV24B-SF-4B-MCV-M25	124 024 270 1103
2M25	HV24B-SF-4B-MCV-2M25	124 024 270 1123
PG21	HV24B-SF-4B-MCV-PG21	124 024 270 1111
2PG21	HV24B-SF-4B-MCV-2PG21	124 024 270 1131

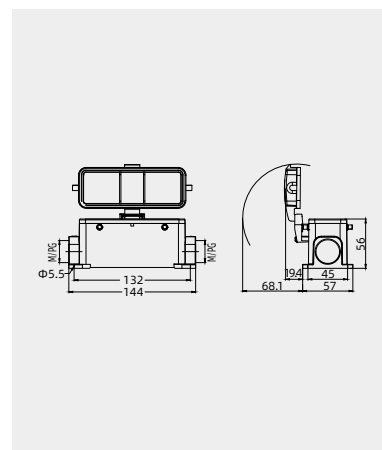

### Surface mounted housings, high construction



Thread	Designation	Order No.
M32	HV24B-SFH-4B-M32	124 024 230 5004
2M32	HV24B-SFH-4B-2M32	124 024 230 5024
PG21	HV24B-SFH-4B-PG21	124 024 230 5011
2PG21	HV24B-SFH-4B-2PG21	124 024 230 5031
PG29	HV24B-SFH-4B-PG29	124 024 230 5012
2PG29	HV24B-SFH-4B-2PG29	124 024 230 5032
with plastic cover		
M32	HV24B-SFH-4B-CV-M32	124 024 270 5004
2M32	HV24B-SFH-4B-CV-2M32	124 024 270 5024
PG21	HV24B-SFH-4B-CV-PG21	124 024 270 5011
2PG21	HV24B-SFH-4B-CV-2PG21	124 024 270 5031
PG29	HV24B-SFH-4B-CV-PG29	124 024 270 5012
2PG29	HV24B-SFH-4B-CV-2PG29	124 024 270 5032
with metal cover		
M32	HV24B-SFH-4B-MCV-M32	124 024 270 5104
2M32	HV24B-SFH-4B-MCV-2M32	124 024 270 5124
PG21	HV24B-SFH-4B-MCV-PG21	124 024 270 5111
2PG21	HV24B-SFH-4B-MCV-2PG21	124 024 270 5131
PG29	HV24B-SFH-4B-MCV-PG29	124 024 270 5112
2PG29	HV24B-SFH-4B-MCV-2PG29	124 024 270 5132

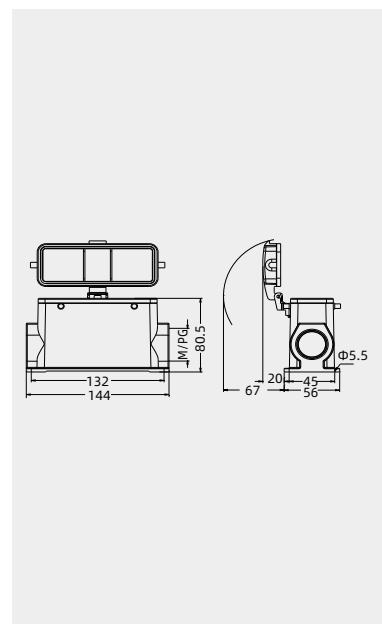

### Protection covers, metal



Connect way	Applications	Designation	Order No.
	for hoods	H24B-MCV-4B/1S	111 024 030 8103
	for housings, without sealing	H24B-MCV-4B/2	111 024 030 8102

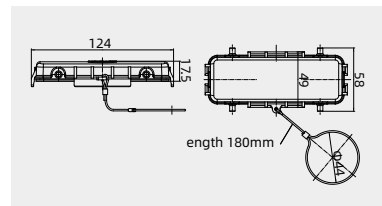

### Protection covers, metal



Connect way	Applications	Designation	Order No.
	for hoods	H24B-MCV-2L/SC.1S	111 024 041 8101
	or housings	H24B-MCV-2L/SC.2	111 024 041 8102

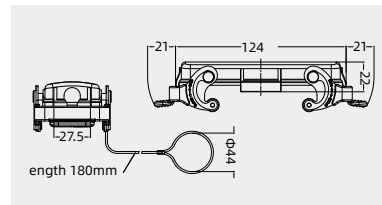

Please refer to page 15-02 for choosing proper model of lock.

24B Metal hoods/housings  
- for high voltage inserts(HVE Series)

Degree of protection: IP65

Hoods, side entry, high construction



Thread	Designation	Order No.
M32	WV24B-SEH-1L/C-M32	124 124 550 5001
PG29	WV24B-SEH-1L/C-PG29	124 124 550 5002
	with sleeve	
M32	WV24B-SEH-1L/C-M32 WS	124 124 555 5004
PG21	WV24B-SEH-1L/C-PG21 WS	124 124 550 5003
PG29	WV24B-SEH-1L/C-PG29 WS	124 124 555 5012

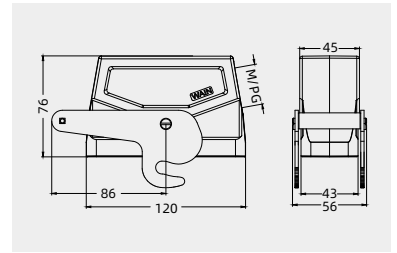

Bulkhead mounted housings



Thread	Designation	Order No.
---	HV24B-BK-2B/C	124 024 355 1001

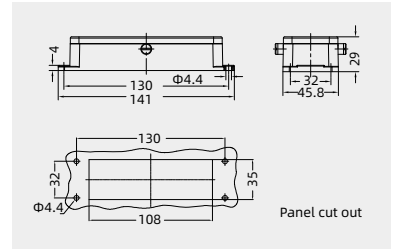

HV24B Metal hoods/housings  
- for high voltage inserts(HVE Series)

Degree of protection: IP65

Hoods, side entry, high construction



Thread	Designation	Order No.
M32	WV24B-SEH-1L/B-M32	124 124 529 5001
PG29	WV24B-SEH-1L/B-PG29	124 124 529 5002
	with sleeve	
M32	WV24B-SEH-1L/B-M32 <i>WS</i>	124 124 525 5004
PG21	WV24B-SEH-1L/B-PG21 <i>WS</i>	124 124 525 5013
PG29	WV24B-SEH-1L/B-PG29 <i>WS</i>	124 124 525 5012

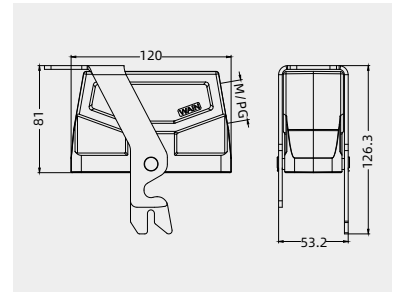

Bulkhead mounted housings



Thread	Designation	Order No.
---	HV24B-BK-2B/B	124 024 315 1001

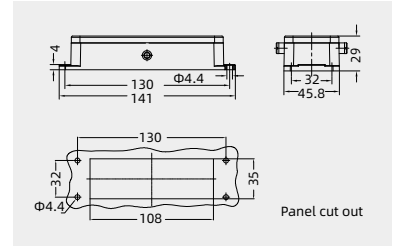

## HV24B Metal hoods/housings - for high voltage inserts(HVE Series)

Degree of protection: IP67

### Hoods, side entry



Thread	Designation	Order No.
M25	WV24B-SE-2B-M25	124 124 510 1001
M32	WV24B-SE-2B-M32	124 124 510 1002
PG21	WV24B-SE-2B-PG21	124 124 510 1003

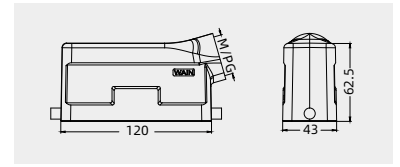

### Hoods, side entry, high construction



Thread	Designation	Order No.
M32	WV24B-SEH-2B-M32	124 124 510 5001
M40	WV24B-SEH-2B-M40	124 124 510 5002
PG21	WV24B-SEH-2B-PG21	124 124 510 5003
PG29	WV24B-SEH-2B-PG29	124 124 510 5004
	with sleeve	
M32	WV24B-SEH-2B-M32 <a href="#">WS</a>	124 124 515 5004
PG21	WV24B-SEH-2B-PG21 <a href="#">WS</a>	124 124 515 5011
PG29	WV24B-SEH-2B-PG29 <a href="#">WS</a>	124 124 515 5012

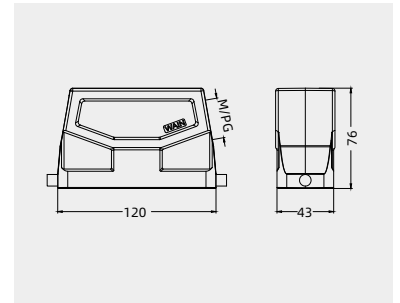

### Hoods, top entry



Thread	Designation	Order No.
M25	WV24B-TE-2B-M25	124 124 410 1001
M32	WV24B-TE-2B-M32	124 124 410 1002
PG21	WV24B-TE-2B-PG21	124 124 410 1003

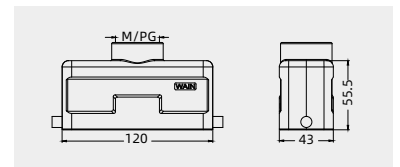

### Hoods, top entry, high construction



Thread	Designation	Order No.
M32	WV24B-TEH-2B-M32	124 124 410 5001
M40	WV24B-TEH-2B-M40	124 124 410 5002
PG21	WV24B-TEH-2B-PG21	124 124 410 5003
PG29	WV24B-TEH-2B-PG29	124 124 410 5004
	with sleeve	
M32	WV24B-TEH-2B-M32 <a href="#">WS</a>	124 124 415 5004
PG21	WV24B-TEH-2B-PG21 <a href="#">WS</a>	124 124 415 5011
PG29	WV24B-TEH-2B-PG29 <a href="#">WS</a>	124 124 415 5012

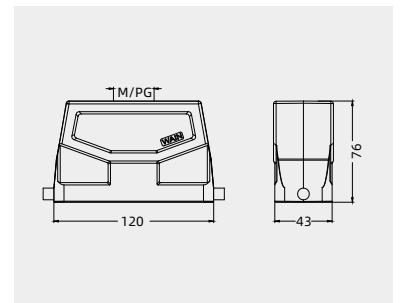

24B Metal hoods/housings  
- for high voltage inserts(HVE Series)

Degree of protection: IP67

Housings, cable to cable



Thread	Designation	Order No.
M25	WV24B-CCT-1L/SC-M25	124 124 721 1001
PG21	WV24B-CCT-1L/SC-PG21	124 124 721 1002

Please refer to page 15-02 for choosing proper model of lock.

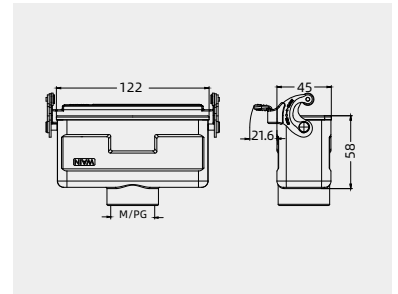

Housings, cable to cable, high construction



Thread	Designation	Order No.
M32	WV24B-CCTH-1L/SC-M32	124 124 721 5001
M40	WV24B-CCTH-1L/SC-M40	124 124 721 5002
PG21	WV24B-CCTH-1L/SC-PG21	124 124 721 5003
PG29	WV24B-CCTH-1L/SC-PG29	124 124 721 5004
M32	WV24B-CCTH-1L/SC-M32 WS with sleeve	124 124 721 5005
PG21	WV24B-CCTH-1L/SC-PG21 WS	124 124 721 5011
PG29	WV24B-CCTH-1L/SC-PG29 WS	124 124 721 5012

Please refer to page 15-02 for choosing proper model of lock.

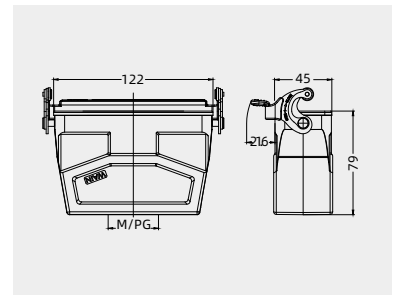

Bulkhead mounted housings



Thread	Designation	Order No.
---	WV24B-BK-1L/SC	124 124 321 1101
---	with plastic cover WV24B-BK-1L/SC-CV	111 124 321 8003
---	with metal cover WV24B-BK-1L/SC-MCV	111 124 321 8004

Please refer to page 15-02 for choosing proper model of lock.

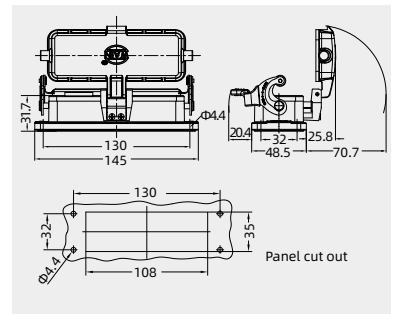

## 24B Metal hoods/housings - for high voltage inserts(HVE Series)

Degree of protection: IP67

### Hoods, side entry



Thread	Designation	Order No.
M25	WV24B-SE-4B-M25	124 124 530 1001
M32	WV24B-SE-4B-M32	124 124 530 1002
PG21	WV24B-SE-4B-PG21	124 124 530 1003

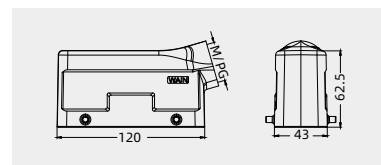

### Hoods, side entry, high construction



Thread	Designation	Order No.
M32	WV24B-SEH-4B-M32	124 124 530 5001
M40	WV24B-SEH-4B-M40	124 124 530 5002
PG21	WV24B-SEH-4B-PG21	124 124 530 5003
PG29	WV24B-SEH-4B-PG29 with sleeve	124 124 530 5004
M32	WV24B-SEH-4B-M32 <i>WS</i>	124 124 530 5007
PG21	WV24B-SEH-4B-PG21 <i>WS</i>	124 124 530 5011
PG29	WV24B-SEH-4B-PG29 <i>WS</i>	124 124 530 5012

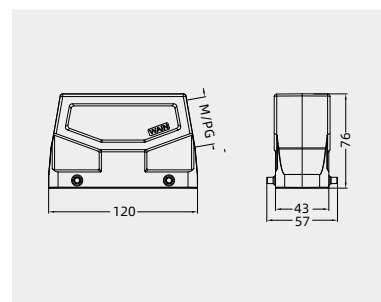

### Hoods, side entry, high construction



Thread	Designation	Order No.
M50	WV24B-SEH-4B-M50	124 124 530 5005
PG36	WV24B-SEH-4B-PG36	124 124 530 5006

Suitable for cable with maximum OD  $\Phi$ 32mm

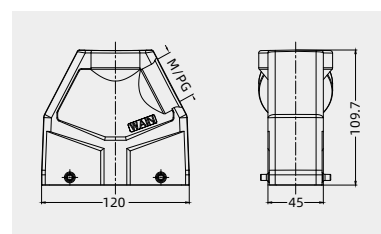

### Hoods, top entry



Thread	Designation	Order No.
M25	WV24B-TE-4B-M25	124 124 430 1001
M32	WV24B-TE-4B-M32	124 124 430 1002
PG21	WV24B-TE-4B-PG21	124 124 430 1003

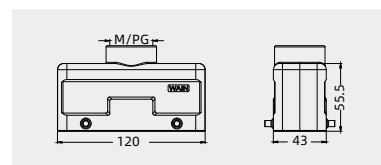

### Hoods, top entry, high construction



Thread	Designation	Order No.
M32	WV24B-TEH-4B-M32	124 124 430 5001
M40	WV24B-TEH-4B-M40	124 124 430 5002
PG21	WV24B-TEH-4B-PG21	124 124 430 5003
PG29	WV24B-TEH-4B-PG29 with sleeve	124 124 430 5004
M32	WV24B-TEH-4B-M32 <i>WS</i>	124 124 430 5008
PG21	WV24B-TEH-4B-PG21 <i>WS</i>	124 124 430 5011
PG29	WV24B-TEH-4B-PG29 <i>WS</i>	124 124 430 5012

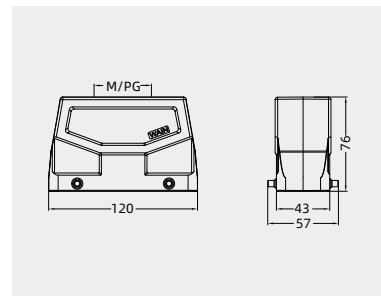

### Hoods, top entry, high construction



Thread	Designation	Order No.
M50	WV24B-TEH-4B-M50	124 124 430 5005
PG36	WV24B-TEH-4B-PG36	124 124 430 5006

Suitable for cable with maximum OD  $\Phi$ 32mm

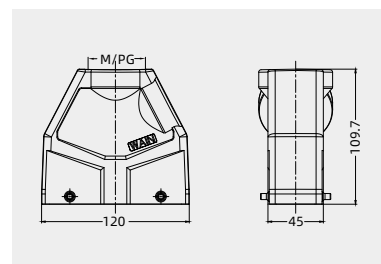

## 24B Metal hoods/housings - for high voltage inserts(HVE Series)

Degree of protection: IP67

### Bulkhead mounted housings



Thread	Designation	Order No.
---	WV24B-BK-2L/SC	124 124 341 1101

Please refer to page 15-02 for choosing proper model of lock.

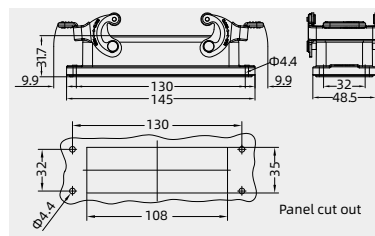

### Housings, cable to cable



Thread	Designation	Order No.
M25	WV24B-CCT-2L/SC-M25	124 124 741 1001
PG21	WV24B-CCT-2L/SC-PG21	124 124 741 1002

Please refer to page 15-02 for choosing proper model of lock.

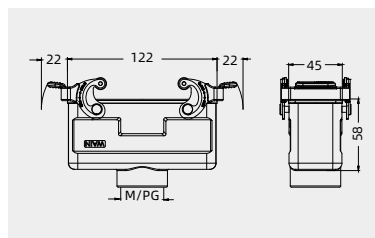

### Housings, cable to cable, high construction



Thread	Designation	Order No.
M32	WV24B-CCTH-2L/SC-M32	124 124 741 5001
M40	WV24B-CCTH-2L/SC-M40	124 124 741 5002
PG21	WV24B-CCTH-2L/SC-PG21	124 124 741 5003
PG29	WV24B-CCTH-2L/SC-PG29	124 124 741 5004
	with sleeve	
M32	WV24B-CCTH-2L/SC-M32 WS	124 124 741 5005
PG21	WV24B-CCTH-2L/SC-PG21 WS	124 124 741 5011
PG29	WV24B-CCTH-2L/SC-PG29 WS	124 124 741 5012

Please refer to page 15-02 for choosing proper model of lock.

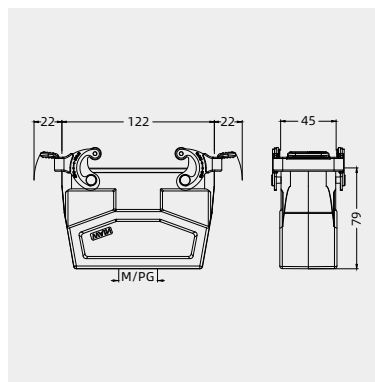

## 24B Metal hoods/housings - for high voltage inserts(HVE Series)

Degree of protection: IP67

### Hoods, side entry



Thread	Designation	Order No.
M25	WV24B-SE-2L/SC-M25	124 124 541 1001
M32	WV24B-SE-2L/SC-M32	124 124 541 1002
PG21	WV24B-SE-2L/SC-PG21	124 124 541 1003

Please refer to page 15-02 for choosing proper model of lock.

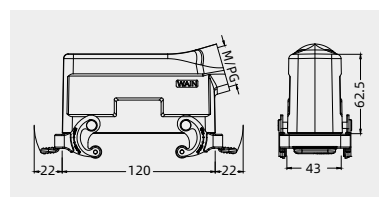

### Hoods, side entry, high construction



Thread	Designation	Order No.
M32	WV24B-SEH-2L/SC-M32	124 124 541 5001
M40	WV24B-SEH-2L/SC-M40	124 124 541 5002
PG21	WV24B-SEH-2L/SC-PG21	124 124 541 5003
PG29	WV24B-SEH-2L/SC-PG29 with sleeve	124 124 541 5004
M32	WV24B-SEH-2L/SC-M32 WS	124 124 541 5005
PG21	WV24B-SEH-2L/SC-PG21 WS	124 124 541 5011
PG29	WV24B-SEH-2L/SC-PG29 WS	124 124 541 5012

Please refer to page 15-02 for choosing proper model of lock.

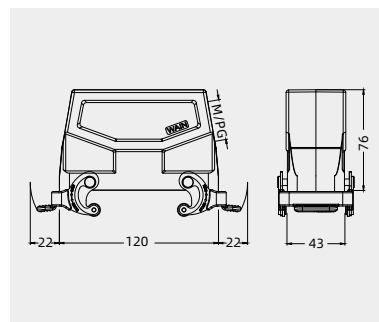

### Hoods, top entry



Thread	Designation	Order No.
M25	WV24B-TE-2L/SC-M25	124 124 441 1001
PG21	WV24B-TE-2L/SC-PG21	124 124 441 1002

Please refer to page 15-02 for choosing proper model of lock.

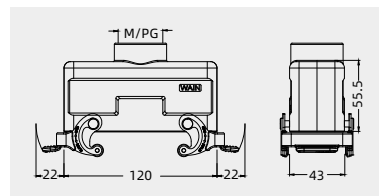

### Hoods, top entry, high construction



Thread	Designation	Order No.
M32	WV24B-TEH-2L/SC-M32	124 124 441 5001
M40	WV24B-TEH-2L/SC-M40	124 124 441 5002
PG21	WV24B-TEH-2L/SC-PG21	124 124 441 5003
PG29	WV24B-TEH-2L/SC-PG29 with sleeve	124 124 441 5004
M32	WV24B-TEH-2L/SC-M32 WS	124 124 441 5005
PG21	WV24B-TEH-2L/SC-PG21 WS	124 124 441 5011
PG29	WV24B-TEH-2L/SC-PG29 WS	124 124 441 5012

Please refer to page 15-02 for choosing proper model of lock.

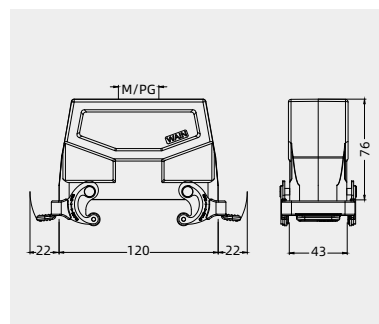

### Bulkhead mounted housings



Thread	Designation	Order No.
---	WV24B-BK-4B	124 124 330 1101

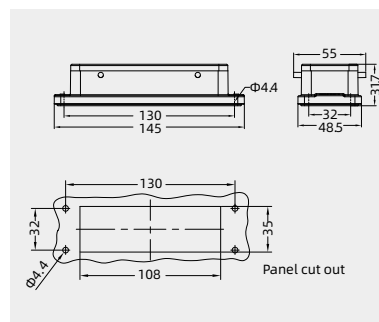



24B Metal hoods/housings  
- for high voltage inserts(HVE Series)

Degree of protection: IP67

Hoods, side entry, high construction



Thread	Designation	Order No.
M32	WV24B-SEH-1L/C-M32	124 124 550 5001
PG29	WV24B-SEH-1L/C-PG29	124 124 550 5002
	with sleeve	
M32	WV24B-SEH-1L/C-M32 <i>WS</i>	124 124 555 5004
PG21	WV24B-SEH-1L/C-PG21 <i>WS</i>	124 124 550 5003
PG29	WV24B-SEH-1L/C-PG29 <i>WS</i>	124 124 555 5012

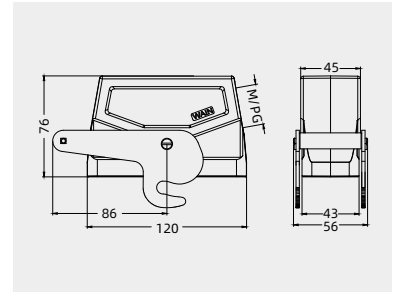

Bulkhead mounted housings



Thread	Designation	Order No.
---	WV24B-BK-2B/C	124 124 350 1101

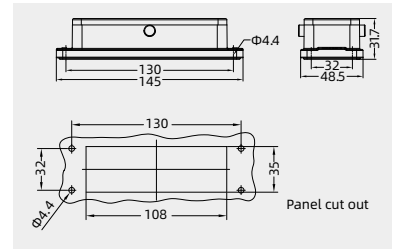

## 24B Metal hoods/housings - for high voltage inserts(HVE Series)

Degree of protection: IP67

Hoods, side entry, high construction



Thread	Designation	Order No.
M32	WV24B-SEH-1L/B-M32	124 124 529 5001
PG29	WV24B-SEH-1L/B-PG29	124 124 529 5002
	with sleeve	
M32	WV24B-SEH-1L/B-M32 <b>WS</b>	124 124 525 5004
PG21	WV24B-SEH-1L/B-PG21 <b>WS</b>	124 124 525 5013
PG29	WV24B-SEH-1L/B-PG29 <b>WS</b>	124 124 525 5012

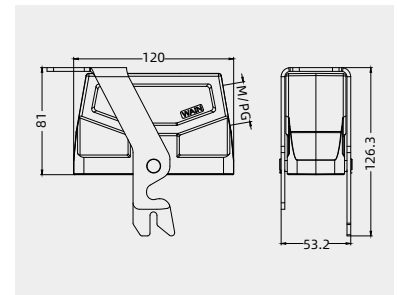

## 32B Metal hoods/housings

Degree of protection: IP65

## Hoods, side entry



Thread	Designation	Order No.
M32	W32B-SE-2B-M32	111 132 510 1001
M40	W32B-SE-2B-M40	111 132 510 1002
M50	W32B-SE-2B-M50	111 132 510 1003
PG29	W32B-SE-2B-PG29	111 132 510 1004
PG36	W32B-SE-2B-PG36	111 132 510 1005
PG42	W32B-SE-2B-PG42	111 132 510 1006

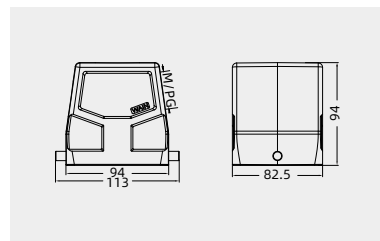

## Hoods, top entry



Thread	Designation	Order No.
M32	W32B-TE-2B-M32	111 132 410 1001
M40	W32B-TE-2B-M40	111 132 410 1002
M50	W32B-TE-2B-M50	111 132 410 1003
PG29	W32B-TE-2B-PG29	111 132 410 1004
PG36	W32B-TE-2B-PG36	111 132 410 1005
PG42	W32B-TE-2B-PG42	111 132 410 1006

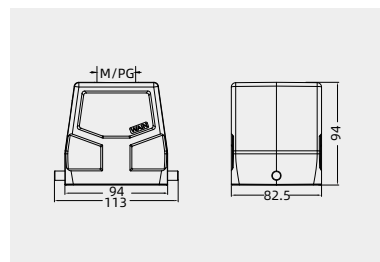

## Bulkhead mounted housings



Thread	Designation	Order No.
---	H32B-BK-1L/S with plastic cover	111 032 325 1001
---	H32B-BK-1L/S-CV with metal cover	111 032 365 1001
---	H32B-BK-1L/S-MCV	111 032 365 1101

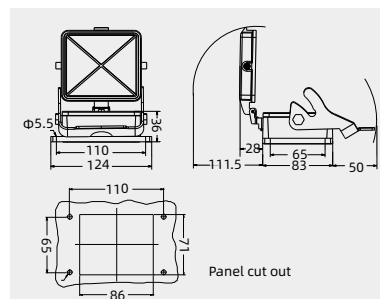

## Surface mounted housings



Thread	Designation	Order No.
M32	H32B-SF-1L/S-M32	111 032 225 1004
2M32	H32B-SF-1L/S-2M32	111 032 225 1024
M40	H32B-SF-1L/S-M40	111 032 225 1005
2M40	H32B-SF-1L/S-2M40	111 032 225 1025
PG29	H32B-SF-1L/S-PG29	111 032 225 1012
2PG29	H32B-SF-1L/S-2PG29	111 032 225 1032
PG36	H32B-SF-1L/S-PG36	111 032 225 1013
2PG36	H32B-SF-1L/S-2PG36	111 032 225 1033

with plastic cover		
M32	H32B-SF-1L/S-CV-M32	111 032 265 1004
2M32	H32B-SF-1L/S-CV-2M32	111 032 265 1024
M40	H32B-SF-1L/S-CV-M40	111 032 265 1005
2M40	H32B-SF-1L/S-CV-2M40	111 032 265 1025
PG29	H32B-SF-1L/S-CV-PG29	111 032 265 1012
2PG29	H32B-SF-1L/S-CV-2PG29	111 032 265 1032
PG36	H32B-SF-1L/S-CV-PG36	111 032 265 1013
2PG36	H32B-SF-1L/S-CV-2PG36	111 032 265 1033
with metal cover		
M32	H32B-SF-1L/S-MCV-M32	111 032 265 1104
2M32	H32B-SF-1L/S-MCV-2M32	111 032 265 1124
M40	H32B-SF-1L/S-MCV-M40	111 032 265 1105
2M40	H32B-SF-1L/S-MCV-2M40	111 032 265 1125
PG29	H32B-SF-1L/S-MCV-PG29	111 032 265 1112
2PG29	H32B-SF-1L/S-MCV-2PG29	111 032 265 1132
PG36	H32B-SF-1L/S-MCV-PG36	111 032 265 1113
2PG36	H32B-SF-1L/S-MCV-2PG36	111 032 265 1133

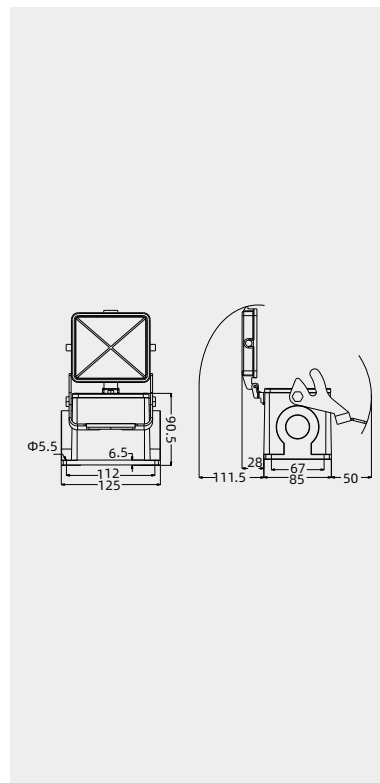

Please refer to page 15-02 for choosing proper model of lock.

## 32B Metal hoods/housings

Degree of protection: IP65

## Hoods, side entry



Thread	Designation	Order No.
M32	W32B-SE-4B-M32	111 132 530 1001
M40	W32B-SE-4B-M40	111 132 530 1002
M50	W32B-SE-4B-M50	111 132 530 1003
PG29	W32B-SE-4B-PG29	111 132 530 1004
PG36	W32B-SE-4B-PG36	111 132 530 1005
PG42	W32B-SE-4B-PG42	111 132 530 1006

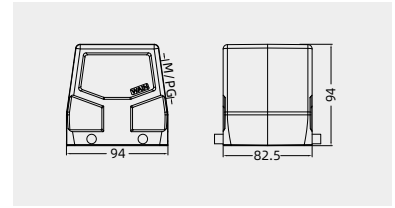

## Hoods, top entry



Thread	Designation	Order No.
M32	W32B-TE-4B-M32	111 132 430 1001
M40	W32B-TE-4B-M40	111 132 430 1002
M50	W32B-TE-4B-M50	111 132 430 1003
PG29	W32B-TE-4B-PG29	111 132 430 1004
PG36	W32B-TE-4B-PG36	111 132 430 1005
PG42	W32B-TE-4B-PG42	111 132 430 1006

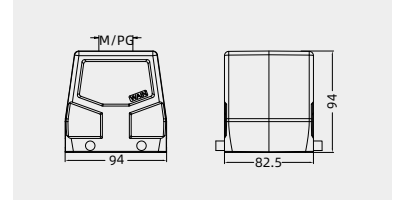

## Bulkhead mounted housings



Thread	Designation	Order No.
---	H32B-BK-2L/SC	111 032 341 1001

Please refer to page 15-02 for choosing proper model of lock.

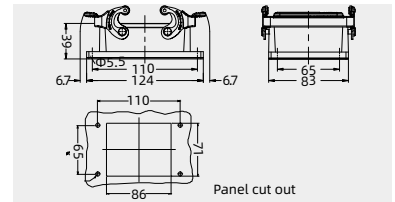

## Surface mounted housings



Thread	Designation	Order No.
M32	H32B-SF-2L/SC-M32	111 032 241 1004
2M32	H32B-SF-2L/SC-2M32	111 032 241 1024
M40	H32B-SF-2L/SC-M40	111 032 241 1005
2M40	H32B-SF-2L/SC-2M40	111 032 241 1025
PG29	H32B-SF-2L/SC-PG29	111 032 241 1012
2PG29	H32B-SF-2L/SC-2PG29	111 032 241 1032
PG36	H32B-SF-2L/SC-PG36	111 032 241 1013
2PG36	H32B-SF-2L/SC-2PG36	111 032 241 1033
2PG42	H32B-SF-2L/SC-2PG42	111 032 241 1034

Please refer to page 15-02 for choosing proper model of lock.

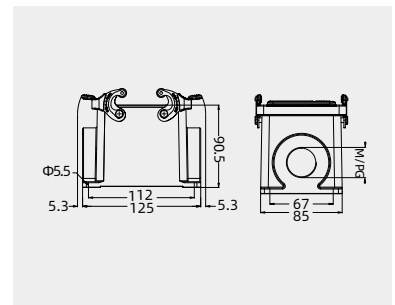

## Housings, cable to cable



Thread	Designation	Order No.
M32	W32B-CCT-2L/SC-M32	111 132 741 1002
M40	W32B-CCT-2L/SC-M40	111 132 741 1003
M50	W32B-CCT-2L/SC-M50	111 132 741 1004
PG29	W32B-CCT-2L/SC-PG29	111 132 741 1005
PG36	W32B-CCT-2L/SC-PG36	111 132 741 1006
PG42	W32B-CCT-2L/SC-PG42	111 132 741 1007

Please refer to page 15-02 for choosing proper model of lock.

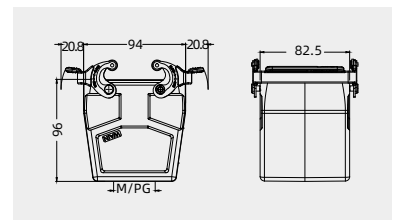

## Protection covers



Connect way	Designation	Order No.
	H32B-MCV-4B/2	111 032 030 8102

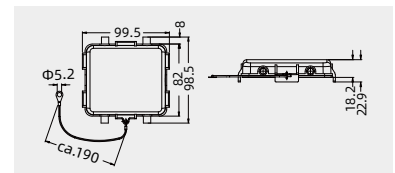

## Protection covers



Connect way	Designation	Order No.
	H32B-MCV-2L/SC.1S	111 032 041 8101

Please refer to page 15-02 for choosing proper model of lock.

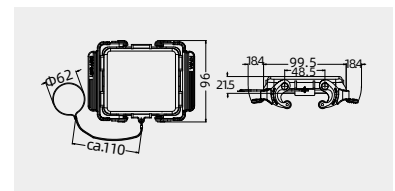

## 32B Metal hoods/housings

Degree of protection: IP67

## Hoods, side entry



Thread	Designation	Order No.
M32	W32B-SE-2B-M32	111 132 510 1001
M40	W32B-SE-2B-M40	111 132 510 1002
M50	W32B-SE-2B-M50	111 132 510 1003
PG29	W32B-SE-2B-PG29	111 132 510 1004
PG36	W32B-SE-2B-PG36	111 132 510 1005
PG42	W32B-SE-2B-PG42	111 132 510 1006

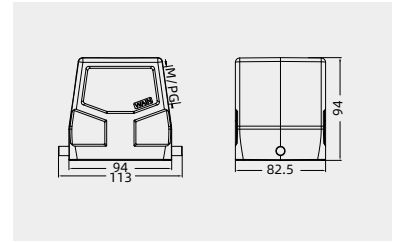

## Hoods, top entry



Thread	Designation	Order No.
M32	W32B-TE-2B-M32	111 132 410 1001
M40	W32B-TE-2B-M40	111 132 410 1002
M50	W32B-TE-2B-M50	111 132 410 1003
PG29	W32B-TE-2B-PG29	111 132 410 1004
PG36	W32B-TE-2B-PG36	111 132 410 1005
PG42	W32B-TE-2B-PG42	111 132 410 1006

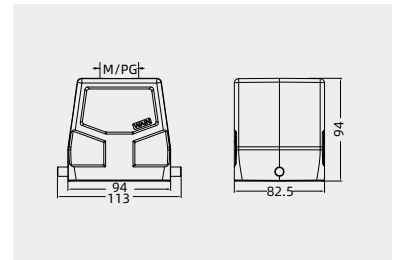

## Bulkhead mounted housings



Thread	Designation	Order No.
---	W32B-BK-1L/S	111 132 325 1001

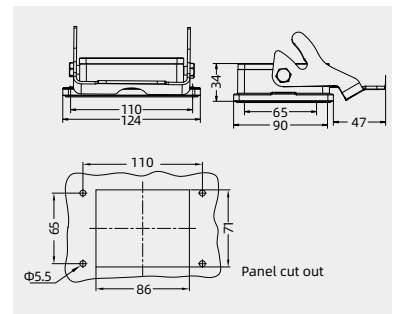

## 32B Metal hoods/housings

Degree of protection: IP67

## Hoods, side entry



Thread	Designation	Order No.
M32	W32B-SE-4B-M32	111 132 530 1001
M40	W32B-SE-4B-M40	111 132 530 1002
M50	W32B-SE-4B-M50	111 132 530 1003
PG29	W32B-SE-4B-PG29	111 132 530 1004
PG36	W32B-SE-4B-PG36	111 132 530 1005
PG42	W32B-SE-4B-PG42	111 132 530 1006

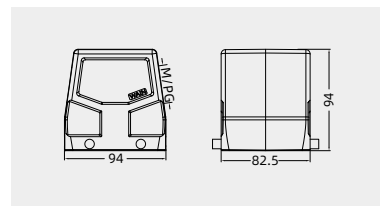

## Hoods, top entry



Thread	Designation	Order No.
M32	W32B-TE-4B-M32	111 132 430 1001
M40	W32B-TE-4B-M40	111 132 430 1002
M50	W32B-TE-4B-M50	111 132 430 1003
PG29	W32B-TE-4B-PG29	111 132 430 1004
PG36	W32B-TE-4B-PG36	111 132 430 1005
PG42	W32B-TE-4B-PG42	111 132 430 1006

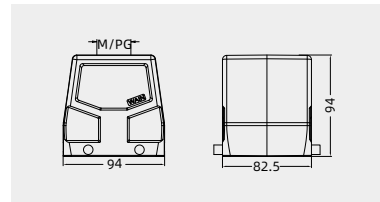

## H

## Bulkhead mounted housings



Thread	Designation	Order No.
---	W32B-BK-2L/SC	111 132 341 1001

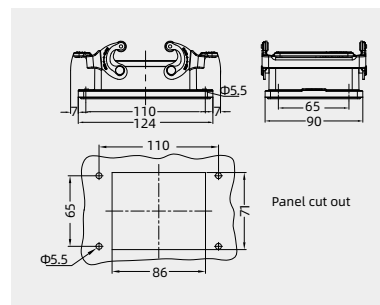

Please refer to page 15-02 for choosing proper model of lock.

## Housings, cable to cable



Thread	Designation	Order No.
M32	W32B-CCT-2L/SC-M32	111 132 741 1002
M40	W32B-CCT-2L/SC-M40	111 132 741 1003
M50	W32B-CCT-2L/SC-M50	111 132 741 1004
PG29	W32B-CCT-2L/SC-PG29	111 132 741 1005
PG36	W32B-CCT-2L/SC-PG36	111 132 741 1006
PG42	W32B-CCT-2L/SC-PG42	111 132 741 1007

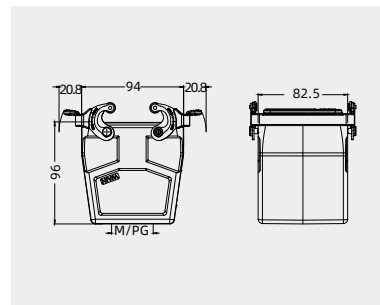

Please refer to page 15-02 for choosing proper model of lock.

# H32B Pressure tight hoods/housings

Degree of protection: IP68/IP69K

## Hoods, side entry



Thread	Designation	Order No.
M40	HP32B-SEH-2S-M40	115 032 520 5005
M50	HP32B-SEH-2S-M50	115 032 520 5006

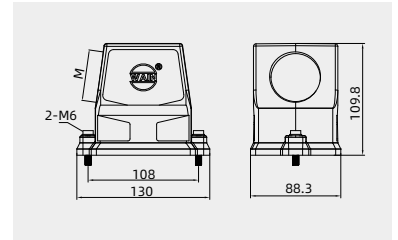

## Hoods, top entry



Thread	Designation	Order No.
M40	HP32B-TEH-2S-M40	115 032 420 5005
M50	HP32B-TEH-2S-M50	115 032 420 5006
M63	HP32B-TEH-2S-M63	115 032 420 5007

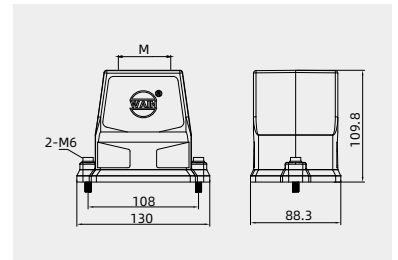

## Bulkhead mounted housings



Thread	Designation	Order No.
---	HP32B-BK-2H	115 032 320 1001

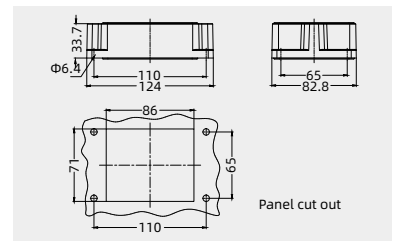

## Protection covers,for housings



Thread	Designation	Order No.
---	HP32B-MCV-2S/2	115 032 020 8102

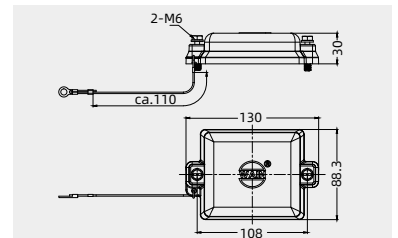

## Protection covers,for hoods



Thread	Designation	Order No.
---	HP32B-MCV-2H/1	115 032 020 8103

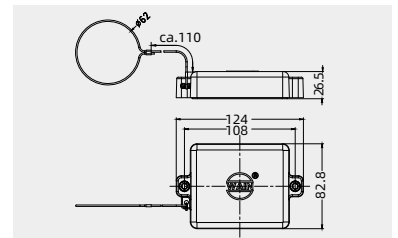

H

## 32B Metal hoods/housings - for high voltage inserts(HVE Series)

Degree of protection: IP65

### Hoods, side entry



Thread	Designation	Order No.
M32	WV32B-SE-2B-M32	124 132 510 1001
PG29	WV32B-SE-2B-PG29	124 132 510 1002

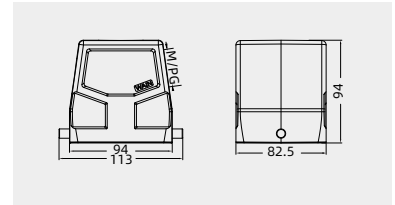

### Hoods, top entry



Thread	Designation	Order No.
M32	WV32B-TE-2B-M32	124 132 410 1001
M40	WV32B-TE-2B-M40	124 132 410 1002
M50	WV32B-TE-2B-M50	124 132 410 1003
PG29	WV32B-TE-2B-PG29	124 132 410 1004
PG36	WV32B-TE-2B-PG36	124 132 410 1005
PG42	WV32B-TE-2B-PG42	124 132 410 1006

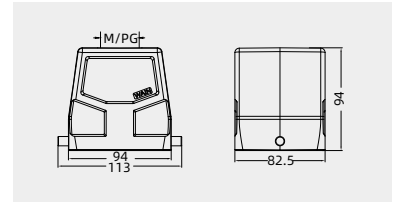

### Bulkhead mounted housings



Thread	Designation	Order No.
---	HV32B-BK-1L/S	124 032 325 1001
---	with plastic cover HV32B-BK-1L/S-CV	124 032 365 1001
---	with metal cover HV32B-BK-1L/S-MCV	124 032 365 1101

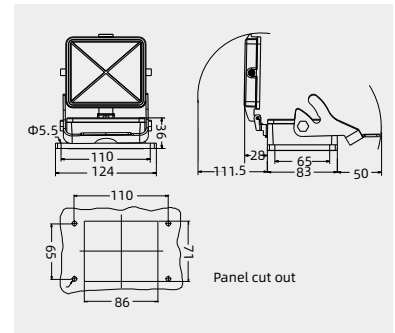

### Surface mounted housings



Thread	Designation	Order No.
M32	HV32B-SF-1L/S-M32	124 032 225 1004
2M32	HV32B-SF-1L/S-2M32	124 032 225 1024
M40	HV32B-SF-1L/S-M40	124 032 225 1005
2M40	HV32B-SF-1L/S-2M40	124 032 225 1025
PG29	HV32B-SF-1L/S-PG29	124 032 225 1012
2PG29	HV32B-SF-1L/S-2PG29	124 032 225 1032
PG36	HV32B-SF-1L/S-PG36	124 032 225 1013
2PG36	HV32B-SF-1L/S-2PG36	124 032 225 1033
	with plastic cover	
M32	HV32B-SF-1L/S-CV-M32	124 032 265 1004
2M32	HV32B-SF-1L/S-CV-2M32	124 032 265 1024
M40	HV32B-SF-1L/S-CV-M40	124 032 265 1005
2M40	HV32B-SF-1L/S-CV-2M40	124 032 265 1025
PG29	HV32B-SF-1L/S-CV-PG29	124 032 265 1012
2PG29	HV32B-SF-1L/S-CV-2PG29	124 032 265 1032
PG36	HV32B-SF-1L/S-CV-PG36	124 032 265 1013
2PG36	HV32B-SF-1L/S-CV-2PG36	124 032 265 1033
	with metal cover	
M32	HV32B-SF-1L/S-MCV-M32	124 032 265 1104
2M32	HV32B-SF-1L/S-MCV-2M32	124 032 265 1124
M40	HV32B-SF-1L/S-MCV-M40	124 032 265 1105
2M40	HV32B-SF-1L/S-MCV-2M40	124 032 265 1125
PG29	HV32B-SF-1L/S-MCV-PG29	124 032 265 1112
2PG29	HV32B-SF-1L/S-MCV-2PG29	124 032 265 1132
PG36	HV32B-SF-1L/S-MCV-PG36	124 032 265 1113
2PG36	HV32B-SF-1L/S-MCV-2PG36	124 032 265 1133

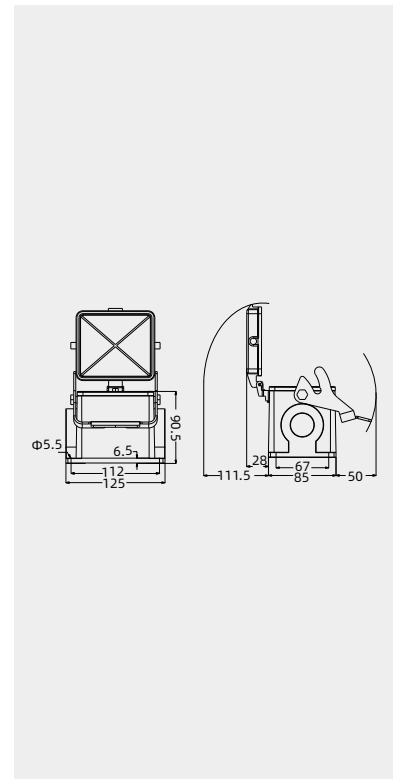



## HV32B Metal hoods/housings - for high voltage inserts(HVE Series)

Degree of protection: IP65

### Hoods, side entry



Thread	Designation	Order No.
M32	WV32B-SE-4B-M32	124 132 530 1001
M40	WV32B-SE-4B-M40	124 132 530 1002
PG29	WV32B-SE-4B-PG29	124 132 530 1003
PG36	WV32B-SE-4B-PG36	124 132 530 1004

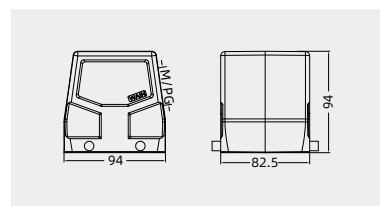

### Hoods, top entry



Thread	Designation	Order No.
M32	WV32B-TE-4B-M32	124 132 430 1001
M40	WV32B-TE-4B-M40	124 132 430 1002
M50	WV32B-TE-4B-M50	124 132 430 1003
PG29	WV32B-TE-4B-PG29	124 132 430 1004
PG36	WV32B-TE-4B-PG36	124 132 430 1005
PG42	WV32B-TE-4B-PG42	124 132 430 1006

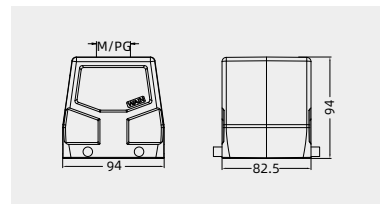

### Bulkhead mounted housings



Thread	Designation	Order No.
---	HV32B-BK-2L/SC	124 032 341 1001

Please refer to page 15-02 for choosing proper model of lock.

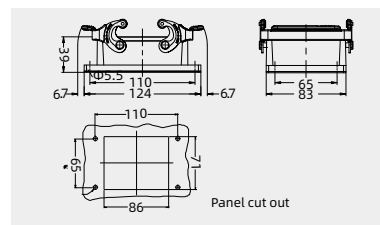

### Surface mounted housings



Thread	Designation	Order No.
M32	HV32B-SF-2L/SC-M32	124 032 241 1004
2M32	HV32B-SF-2L/SC-2M32	124 032 241 1024
M40	HV32B-SF-2L/SC-M40	124 032 241 1005
2M40	HV32B-SF-2L/SC-2M40	124 032 241 1025
PG29	HV32B-SF-2L/SC-PG29	124 032 241 1012
2PG29	HV32B-SF-2L/SC-2PG29	124 032 241 1032
PG36	HV32B-SF-2L/SC-PG36	124 032 241 1013
2PG36	HV32B-SF-2L/SC-2PG36	124 032 241 1033

Please refer to page 15-02 for choosing proper model of lock.

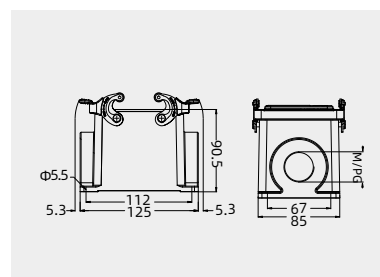

### Housings, cable to cable



Thread	Designation	Order No.
M32	WV32B-CCT-2L/SC-M32	124 132 741 1001
M40	WV32B-CCT-2L/SC-M40	124 132 741 1002
PG29	WV32B-CCT-2L/SC-PG29	124 132 741 1003
PG36	WV32B-CCT-2L/SC-PG36	124 132 741 1004
PG42	WV32B-CCT-2L/SC-PG42	124 132 741 1005

Please refer to page 15-02 for choosing proper model of lock.

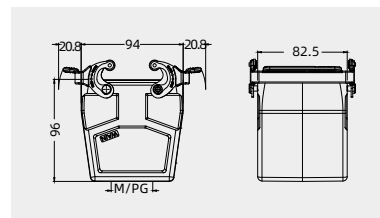

### Protection covers



Connect way	Designation	Order No.
	H32B-MCV-4B/2	111 032 030 8102

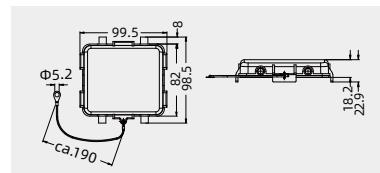

### Protection covers



Connect way	Designation	Order No.
	H32B-MCV-2L/SC.1S	111 032 041 8101

Please refer to page 15-02 for choosing proper model of lock.

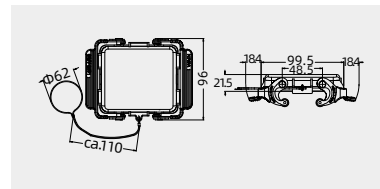

HV32B Metal hoods/housings  
- for high voltage inserts(HVE Series)

Degree of protection: IP65

Hoods, side entry



Thread	Designation	Order No.
M32	WV32B-SE-2B-M32	124 132 510 1001
PG29	WV32B-SE-2B-PG29	124 132 510 1002

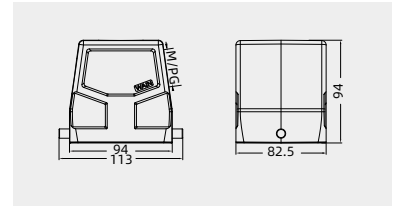

Hoods, top entry



Thread	Designation	Order No.
M32	WV32B-TE-2B-M32	124 132 410 1001
M40	WV32B-TE-2B-M40	124 132 410 1002
M50	WV32B-TE-2B-M50	124 132 410 1003
PG29	WV32B-TE-2B-PG29	124 132 410 1004
PG36	WV32B-TE-2B-PG36	124 132 410 1005
PG42	WV32B-TE-2B-PG42	124 132 410 1006

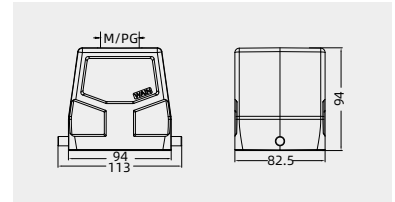

H

Bulkhead mounted housings



Thread	Designation	Order No.
---	WV32B-BK-1L/S	124 132 325 1101

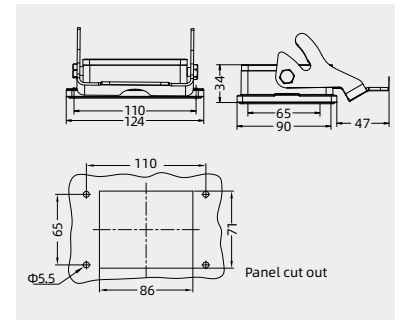

HV32B Metal hoods/housings  
- for high voltage inserts(HVE Series)

Degree of protection: IP67

Hoods, side entry



Thread	Designation	Order No.
M32	WV32B-SE-4B-M32	124 132 530 1001
M40	WV32B-SE-4B-M40	124 132 530 1002
PG29	WV32B-SE-4B-PG29	124 132 530 1003
PG36	WV32B-SE-4B-PG36	124 132 530 1004

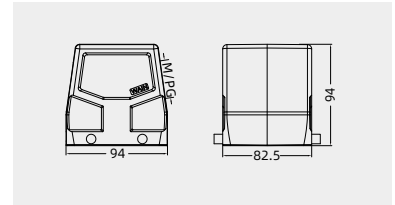

Hoods, top entry



Thread	Designation	Order No.
M32	WV32B-TE-4B-M32	124 132 430 1001
M40	WV32B-TE-4B-M40	124 132 430 1002
M50	WV32B-TE-4B-M50	124 132 430 1003
PG29	WV32B-TE-4B-PG29	124 132 430 1004
PG36	WV32B-TE-4B-PG36	124 132 430 1005
PG42	WV32B-TE-4B-PG42	124 132 430 1006

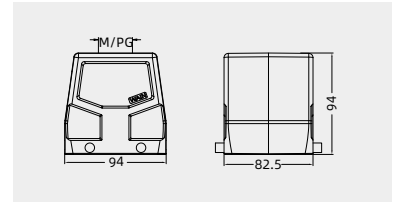

Bulkhead mounted housings



Thread	Designation	Order No.
---	WV32B-BK-2L/SC	124 132 341 1101

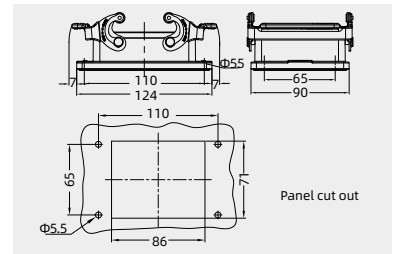

Please refer to page 15-02 for choosing proper model of lock.

Housings, cable to cable



Thread	Designation	Order No.
M32	WV32B-CCT-2L/SC-M32	124 132 741 1001
M40	WV32B-CCT-2L/SC-M40	124 132 741 1002
PG29	WV32B-CCT-2L/SC-PG29	124 132 741 1003
PG36	WV32B-CCT-2L/SC-PG36	124 132 741 1004
PG42	WV32B-CCT-2L/SC-PG42	124 132 741 1005

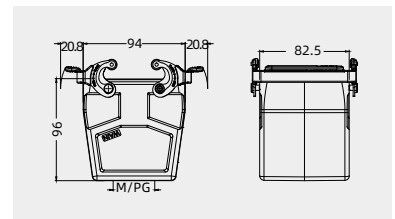

Please refer to page 15-02 for choosing proper model of lock.

## 48B Metal hoods/housings

Degree of protection: IP65

## Hoods, side entry



Thread	Designation	Order No.
M32	H48B-SE-2B-M32	111 048 515 1004
M40	H48B-SE-2B-M40	111 048 515 1005
M50	H48B-SE-2B-M50	111 048 515 1006
PG29	H48B-SE-2B-PG29	111 048 515 1012
PG36	H48B-SE-2B-PG36	111 048 515 1013
PG42	H48B-SE-2B-PG42	111 048 515 1014

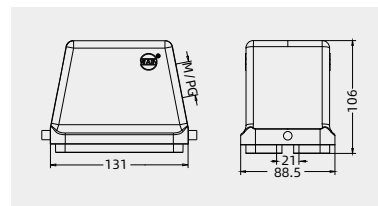

## Hoods, top entry



Thread	Designation	Order No.
M32	H48B-TE-2B-M32	111 048 415 1004
M40	H48B-TE-2B-M40	111 048 415 1005
M50	H48B-TE-2B-M50	111 048 415 1006
PG29	H48B-TE-2B-PG29	111 048 415 1012
PG36	H48B-TE-2B-PG36	111 048 415 1013
PG42	H48B-TE-2B-PG42	111 048 415 1014

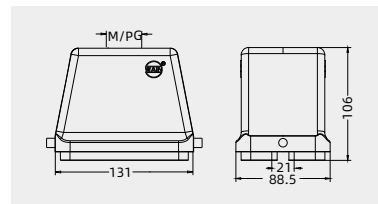

## Bulkhead mounted housings



Thread	Designation	Order No.
---	H48B-BK-1L/S	111 048 325 1001
---	with plastic cover H48B-BK-1L/S-CV	111 048 365 1001
---	with metal cover H48B-BK-1L/S-MCV	111 048 365 1101

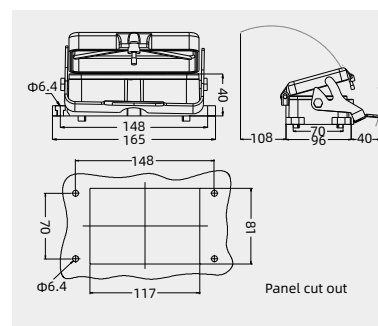

## Surface mounted housings



Thread	Designation	Order No.
M32	H48B-SF-1L/S-M32	111 048 225 1004
2M32	H48B-SF-1L/S-2M32	111 048 225 1024
M40	H48B-SF-1L/S-M40	111 048 225 1005
2M40	H48B-SF-1L/S-2M40	111 048 225 1025
PG29	H48B-SF-1L/S-PG29	111 048 225 1012
2PG29	H48B-SF-1L/S-2PG29	111 048 225 1032
PG36	H48B-SF-1L/S-PG36	111 048 225 1013
2PG36	H48B-SF-1L/S-2PG36	111 048 225 1033
---	with plastic cover	
M32	H48B-SF-1L/S-CV-M32	111 048 265 1004
2M32	H48B-SF-1L/S-CV-2M32	111 048 265 1024
M40	H48B-SF-1L/S-CV-M40	111 048 265 1005
2M40	H48B-SF-1L/S-CV-2M40	111 048 265 1025
PG29	H48B-SF-1L/S-CV-PG29	111 048 265 1012
2PG29	H48B-SF-1L/S-CV-2PG29	111 048 265 1032
PG36	H48B-SF-1L/S-CV-PG36	111 048 265 1013
2PG36	H48B-SF-1L/S-CV-2PG36	111 048 265 1033
---	with metal cover	
M32	H48B-SF-1L/S-MCV-M32	111 048 265 1104
2M32	H48B-SF-1L/S-MCV-2M32	111 048 265 1124
M40	H48B-SF-1L/S-MCV-M40	111 048 265 1105
2M40	H48B-SF-1L/S-MCV-2M40	111 048 265 1125
PG29	H48B-SF-1L/S-MCV-PG29	111 048 265 1112
2PG29	H48B-SF-1L/S-MCV-2PG29	111 048 265 1132
PG36	H48B-SF-1L/S-MCV-PG36	111 048 265 1113
2PG36	H48B-SF-1L/S-MCV-2PG36	111 048 265 1133

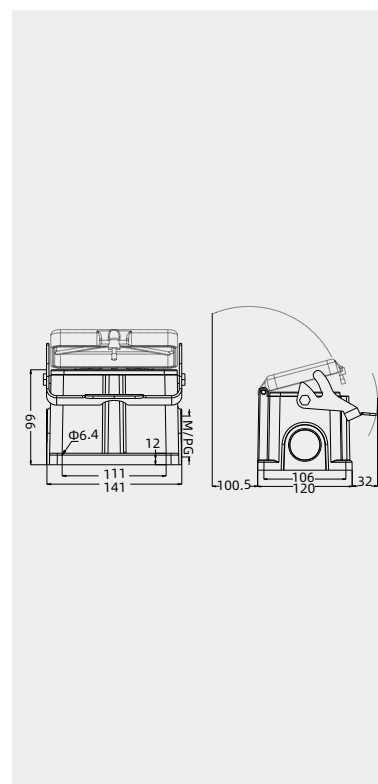

## 48B Metal hoods/housings

Degree of protection: IP65

Protection covers



Connect way	Designation	Order No.
	H48B-MCV-1L/S.1S	111 048 025 8001

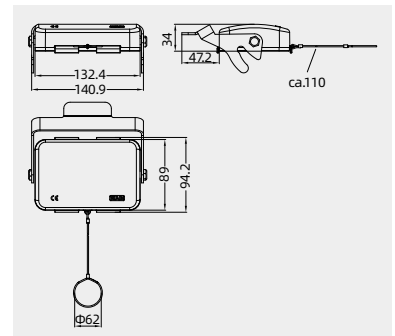

48B Metal hoods/housings  
-Suitable for harsh environment(anti-corrosion)

Degree of protection: IP65

Hoods, side entry



Thread	Designation	Order No.
M32	H48B-MSE-2B-M32	112 048 510 1004
M40	H48B-MSE-2B-M40	112 048 510 1005
M50	H48B-MSE-2B-M50	112 048 510 1006

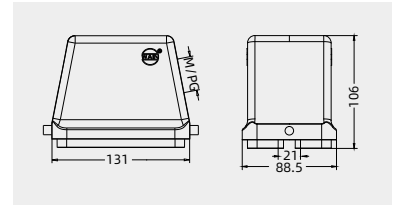

Hoods, top entry



Thread	Designation	Order No.
M40	H48B-MTE-2B-M40	112 048 410 1005
M50	H48B-MTE-2B-M50	112 048 410 1006

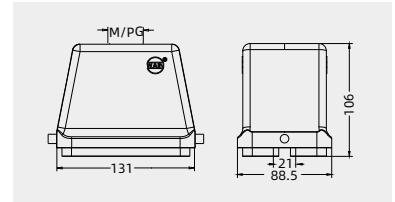

Bulkhead mounted housings



Thread	Designation	Order No.
---	with plastic cover H48B-MBK-1L/S-CV	112 048 365 1001
---	with metal cover H48B-MBK-1L/S-MMCV	112 048 365 1101

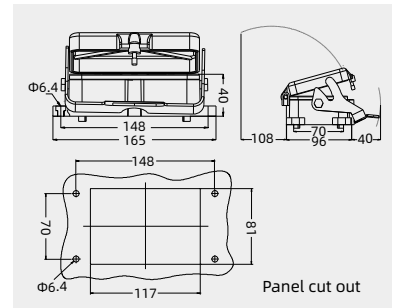

Please refer to page 15-02 for choosing proper model of lock.

Protection covers



Connect way	Designation	Order No.
	H48B-MMCV-1L/S.1S	112 048 025 8001

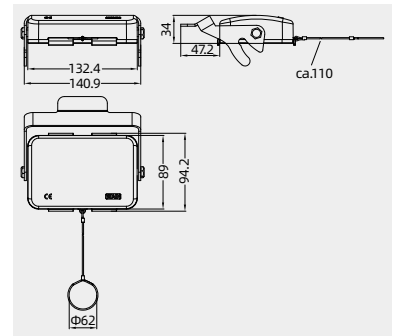

48B Metal hoods/housings  
- for high voltage inserts(HVE Series)

Degree of protection: IP65

Hoods, side entry



Thread	Designation	Order No.
M32	HV48B-SE-2B-M32	124 048 515 1004
M40	HV48B-SE-2B-M40	124 048 515 1005
M50	HV48B-SE-2B-M50	124 048 515 1006
PG29	HV48B-SE-2B-PG29	124 048 515 1012
PG36	HV48B-SE-2B-PG36	124 048 515 1013
PG42	HV48B-SE-2B-PG42	124 048 515 1014

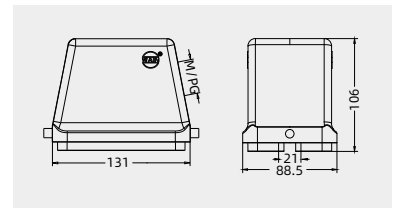

Hoods, top entry



Thread	Designation	Order No.
M32	HV48B-TE-2B-M32	124 048 415 1004
M40	HV48B-TE-2B-M40	124 048 415 1005
M50	HV48B-TE-2B-M50	124 048 415 1006
PG29	HV48B-TE-2B-PG29	124 048 415 1012
PG36	HV48B-TE-2B-PG36	124 048 415 1013
PG42	HV48B-TE-2B-PG42	124 048 415 1014

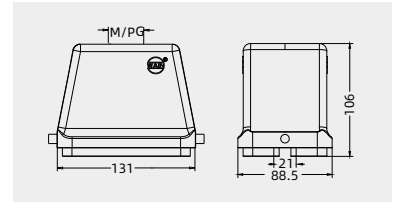

Bulkhead mounted housings



Thread	Designation	Order No.
---	HV48B-BK-1L/S	124 048 325 1001
---	with plastic cover HV48B-BK-1L/S-CV	124 048 365 1001
---	with metal cover HV48B-BK-1L/S-MCV	124 048 365 1101

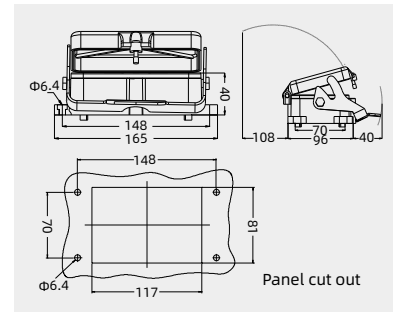

Surface mounted housings



Thread	Designation	Order No.
M32	HV48B-SF-1L/S-M32	124 048 225 1004
2M32	HV48B-SF-1L/S-2M32	124 048 225 1024
M40	HV48B-SF-1L/S-M40	124 048 225 1005
2M40	HV48B-SF-1L/S-2M40	124 048 225 1025
PG29	HV48B-SF-1L/S-PG29	124 048 225 1012
2PG29	HV48B-SF-1L/S-2PG29	124 048 225 1032
PG36	HV48B-SF-1L/S-PG36	124 048 225 1013
2PG36	HV48B-SF-1L/S-2PG36	124 048 225 1033
	with plastic cover	
M32	HV48B-SF-1L/S-CV-M32	124 048 265 1004
2M32	HV48B-SF-1L/S-CV-2M32	124 048 265 1024
M40	HV48B-SF-1L/S-CV-M40	124 048 265 1005
2M40	HV48B-SF-1L/S-CV-2M40	124 048 265 1025
PG29	HV48B-SF-1L/S-CV-PG29	124 048 265 1012
2PG29	HV48B-SF-1L/S-CV-2PG29	124 048 265 1032
PG36	HV48B-SF-1L/S-CV-PG36	124 048 265 1013
2PG36	HV48B-SF-1L/S-CV-2PG36	124 048 265 1033
	with metal cover	
M32	HV48B-SF-1L/S-MCV-M32	124 048 265 1104
2M32	HV48B-SF-1L/S-MCV-2M32	124 048 265 1124
M40	HV48B-SF-1L/S-MCV-M40	124 048 265 1105
2M40	HV48B-SF-1L/S-MCV-2M40	124 048 265 1125
PG29	HV48B-SF-1L/S-MCV-PG29	124 048 265 1112
2PG29	HV48B-SF-1L/S-MCV-2PG29	124 048 265 1132
PG36	HV48B-SF-1L/S-MCV-PG36	124 048 265 1113
2PG36	HV48B-SF-1L/S-MCV-2PG36	124 048 265 1133

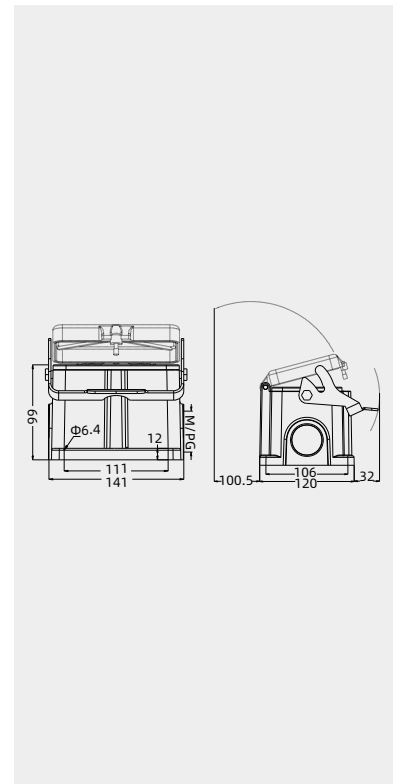

HC Plastic hoods/housings

Degree of protection: IP65

Hoods, side entry



Thread	Designation	Order No.
PG16	HC.P-SE-2B-PG16	130 008 510 1010

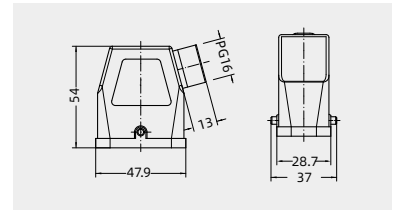

Hoods, top entry



Thread	Designation	Order No.
M25	HC.P-TE-2B-M25	130 008 410 1003
PG16	HC.P-TE-2B-PG16	130 008 410 1010
PG21	HC.P-TE-2B-PG21	130 008 410 1011

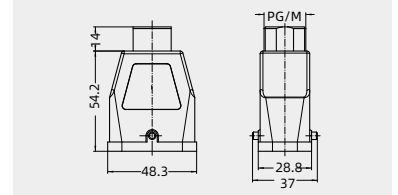

Hoods, top entry



Thread	Designation	Order No.
PAFS18	HC.P-TE-2B-PAFS18	130 008 410 1091

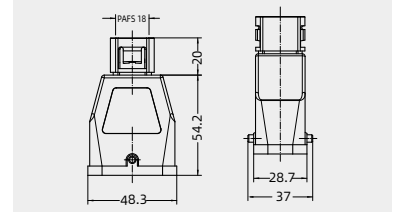

Bulkhead mounted housings



Thread	Designation	Order No.
---	HC.P-BK-1L-SE	130 008 927 1001

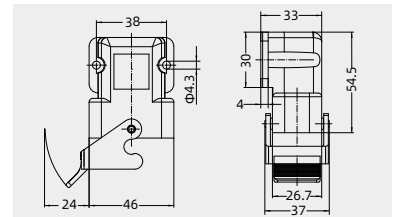

Surface mounted housings



Thread	Designation	Order No.
PG16	HC.P-SF-1L-PG16	130 008 227 1010

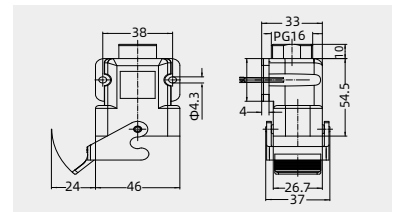

Bulkhead mounted housings



Thread	Designation	Order No.
---	HC.P-BK-1L	130 008 327 1001

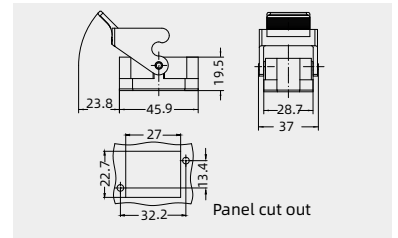



# HC Plastic hoods/housings

## Degree of protection: IP65

### Housings, cable to cable



Thread	Designation	Order No.
M25	HC.P-CCT-1L-M25	130 008 727 1003
PG16	HC.P-CCT-1L-PG16	130 008 727 1010

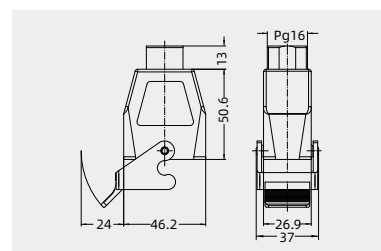

### Housings, cable to cable



Thread	Designation	Order No.
PAFS18	HC.P-CCT-1L-PAFS18	130 008 727 1001

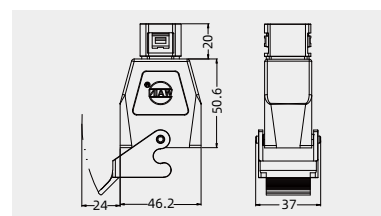

### Protection covers



Thread	Designation	Order No.
---	without sealing	
	HC.P-CV-2B/1	130 008 010 8001
	Without sealing	
	HC.P-CV-2B/2	130 008 010 8002

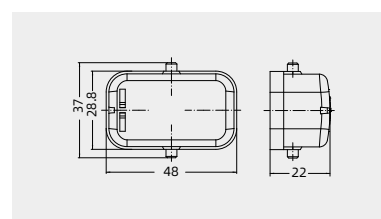

### Cable gland, for hoods



Thread	Designation	Order No.
M25	WNAPC-M25B(D6.5-9.5)	102 112 018 2002
M25	WNAPC-M25B(D10.5-14)	102 112 018 2004
M25	WNAPC-M25B(D14-17)	102 112 018 2006
PG16	WNAPC-PG16B(D11.5-15.5)	102 112 005 2002
PG21	WNAPC-PG21B(D14-18)	102 112 006 2002
PG21	WNAPC-PG21B(D17-20.5)	102 112 006 2004

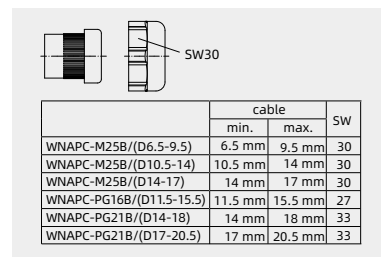

### Cable gland, for housings



Thread	Designation	Order No.
PG16	WNAPC-PG16BS(D6.5-9.5)	102 112 005 2102
PG16	WNAPC-PG16BS(D11.5-15.5)	102 112 005 2004

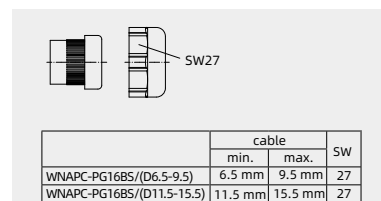

HC Metal hoods/housings

Epoxy power paint

Degree of protection: IP65

Hoods, side entry



Thread	Designation	Order No.
M25	HC-SE-2B-M25	130 008 510 1003

Cannot match the Inserts:130 008 510 1003, 130 608 510 1003 please find the details on page 11-17

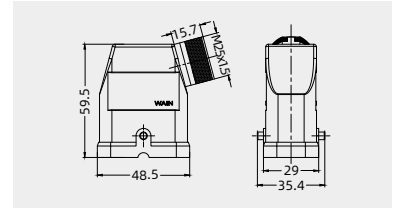

Hoods, side entry, high construction



Thread	Designation	Order No.
M25	HC-SEH-2B-M25	130 008 510 5003

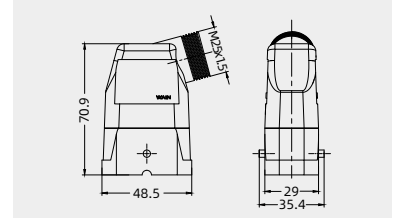

Hoods, top entry, high construction



Thread	Designation	Order No.
M25	HC-TEH-2B-M25	130 008 410 5003

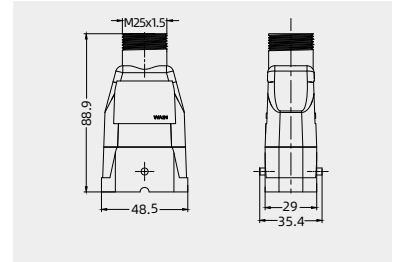

Hoods, side entry, high construction Split type



Thread	Designation	Order No.
M25	HC-SEHS-2B-M25	130 008 510 5103

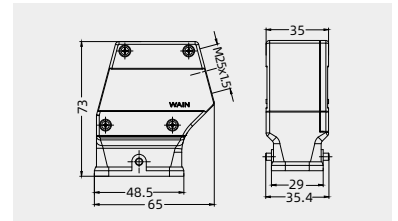

Hoods, top entry, high construction Split type



Thread	Designation	Order No.
M25	HC-TEHS-2B-M25	130 008 410 5103

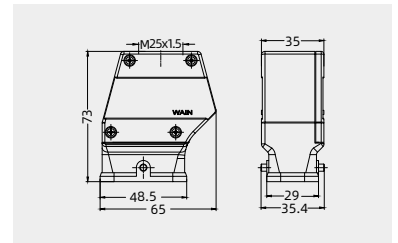

Bulkhead mounted housings



Thread	Designation	Order No.
---	HC-BK-1L/S	130 008 325 1001

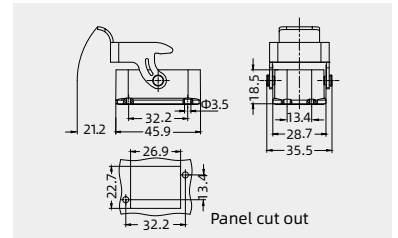

HC Metal hoods/housings

Epoxy power paint

Degree of protection: IP65

Protection covers



Thread	Designation	Order No.
	without sealing	
---	HC-MCV-2B/1	130 008 010 8101
	Without sealing	
---	HC-MCV-2B/2	130 008 010 8102

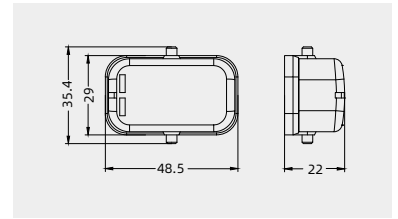

Cable gland, for hoods



Thread	Designation	Order No.
M25	WNAMC-M25(D6.5-9.5)	102 111 018 1001
M25	WNAMC-M25(D10.5-14)	102 111 018 1002
M25	WNAMC-M25(D14-17)	102 111 018 1003

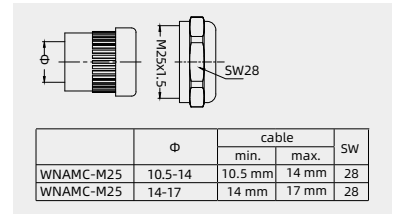

# HC Metal hoods/housings(EMC)

Nickel plating

Degree of protection: IP65

## Hoods, side entry



Thread	Designation	Order No.
M25	EMC.HC-SE-2B-M25	130 608 510 1003

Cannot match the Inserts:130 008 510 1003, 130 608 510 1003 please find the details on page 11-17

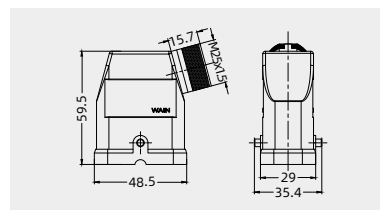

## Hoods, side entry, high construction



Thread	Designation	Order No.
M25	EMC.HC-SEH-2B-M25	130 608 510 5003

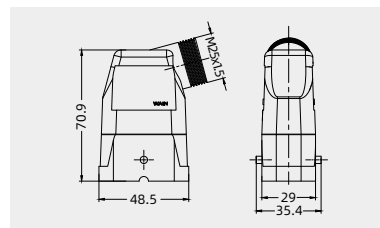

## Hoods, top entry, high construction



Thread	Designation	Order No.
M25	EMC.HC-TEH-2B-M25	130 608 410 5003

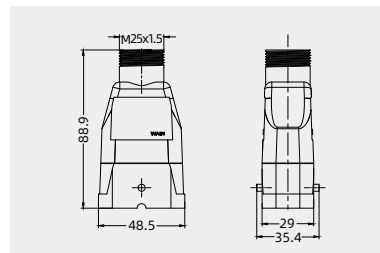

## Hoods, side entry, high construction Split type



Thread	Designation	Order No.
M25	EMC.HC-SEHS-2B-M25	130 608 510 5103

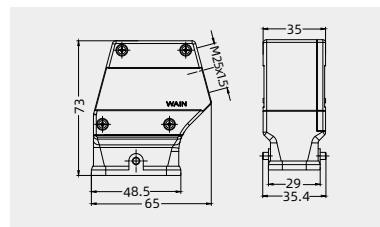

## Hoods, top entry, high construction Split type



Thread	Designation	Order No.
M25	EMC.HC-TEHS-2B-M25	130 608 410 5103

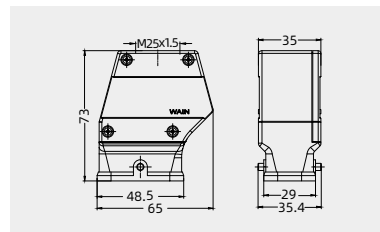

## Bulkhead mounted housings



Thread	Designation	Order No.
---	EMC.HC-BK-1L/S	130 608 325 1001

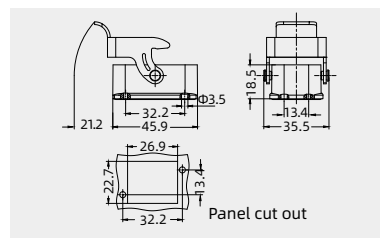

HC Metal hoods/housings(EMC)

Nickel plating

Degree of protection: IP65

Protection covers



Thread	Designation	Order No.
	without sealing	
---	EMC.HC-MCV-2B/1	130 608 010 8101
	Without sealing	
---	EMC.HC-MCV-2B/2	130 608 010 8102

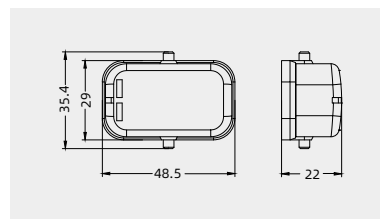

Cable gland, for hoods



Thread	Designation	Order No.
M25	EMC.WNAMC-M25(D10.5-14/D6-11)	102 118 018 1001
M25	EMC.WNAMC-M25(D14-17/D9-13)	102 118 018 1003
M25	EMC.WNAMC-M25(D10.5-14/D9-13)	102 118 018 1002

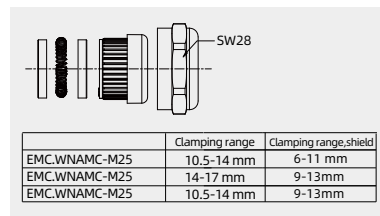

## Seal part

Material: EPDM

## Bulkhead mounted housings



Thread	Designation	Order No.
---	H10A-BK-1L/SC-T	110 010 321 1002
---	H16A-BK-1L/SC-T	110 016 321 1002
---	H6B-BK-1L/SC-T	111 006 321 1007
---	H10B-BK-2L/SC-T	111 010 341 1005
---	H16B-BK-2L/SC-T	111 016 341 1005
---	H24B-BK-2L/SC-T	111 024 341 1003

The thickened bottom gasket shown above is applicable to the regular BK housing of the same specification of H series.

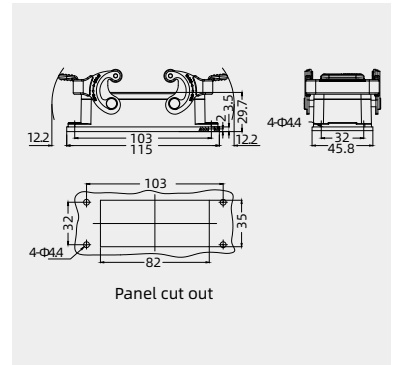

## H

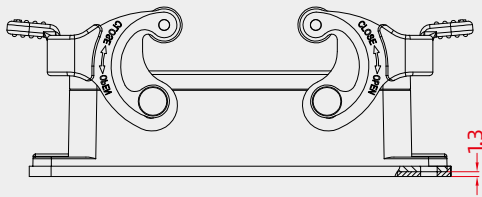

H16B-BK-2L/SC  
(Regular gasket)

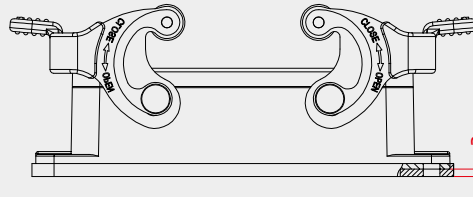

H16B-BK-2L/SC-T  
(thickened gasket) (Thickened position)

**Performance characteristics:**

- Color: dark grey
- Increase the compression thickness of sealing surface  
Take "H16B-BK-2L/SC-T" as an example:  
The thickness of regular gasket is 1.3mm, and thickened gasket is 2mm
- Limiting temperatures: -40°C ...+125°C
- Gasket material: EPDM
- It has good weather resistance and can effectively slowdown aging!

## Seal part

Material:CR

Seal part



Thread	Designation	Order No.
---	6B-F/N	903 000 000 0107
---	10B-F/N	903 000 000 0040
---	16B-F/N	903 000 000 0062
---	24B-F/N	903 000 000 0081

The thickened bottom gasket shown above is applicable to the regular BK housing of the same specification of H series.

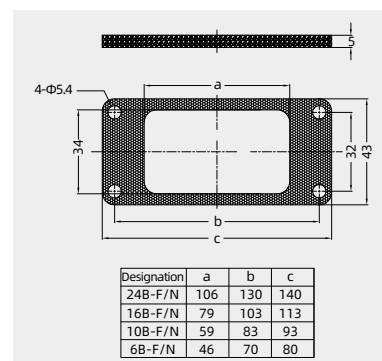
**Performance characteristics:**

- Color: beige
- The thickness of the gasket is 5mm
- Limiting temperatures: -40°C ...+125°C
- Gasket material: CR
- Good weather resistance, ozone resistance, oil resistance and solvent resistance, suitable for pitch system in wind power industry.

# PCB Connector





## PCB Connector



### Technical specification

Specifications	DIN EN 60 664 DIN EN 61 984
Approvals	
Inserts	
No.of contact	48
Termination length	4.5mm
Contact rows	3
Contact spacing	3.81mm/5.08mm
Rated current	6A
Test voltage Ur.m.s	1.5KV(contact-contact) 2.5KV(contact-ground)
Insulatin resistance	$\geq 10^{12}\Omega$
Flammability acc.to UL94	V0
Material	thermoplastic rsein
Colour	RAL 7032(light grey)
Temperature range	-55°C ...+125°C
Mating cycles	$\geq 50$
Contacts	
Terminal	wave soldering termination
Contact	$\leq 15m\Omega$
Material	copper alloy
Susface	selective gold plating

PCB Connector

6A 48

Inserts

Inserts



Inserts	Designation	Order No.
male	WBF-048-MSHT	139 048 013 0001

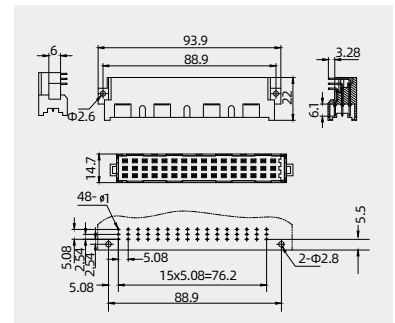

Inserts



Description	Designation	Order No.
female	WBF-048-FTHT	139 048 024 0001

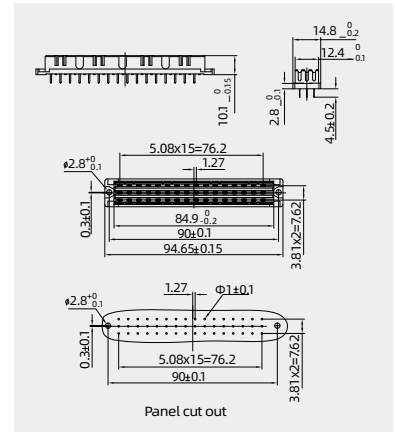

Inserts

order crimp contacts separately



Description	Designation	Order No.
female	WBF-048-FC	139 048 020 0001

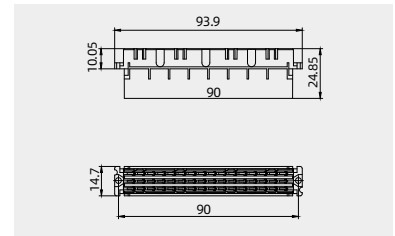

contacts



Description	Designation	Order No.
	CBGF-1.5P	101 040 202 0901

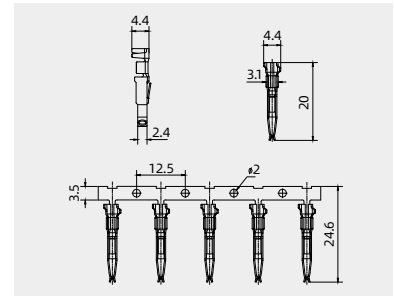

Contact removal tool



Application	Designation	Order NO.
	TL-BR	198 001 000 0040

Hoods/Housings

Description	Designation	Order No.
	W20D-2TE/2SE	120 120 900 1001

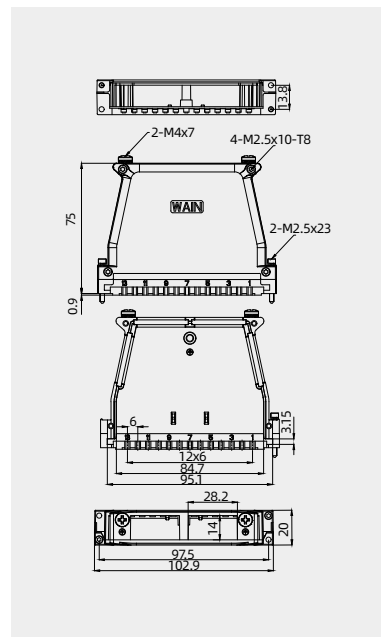

Cable clamp

Description	Designation	Order No.
	W20D-CLP	198 002 006 0021

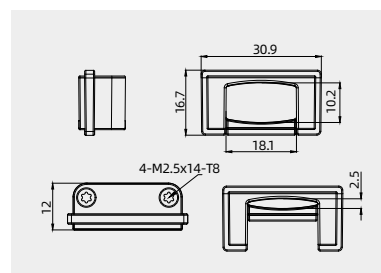

Outlet-hole cover plate

Description	Designation	Order No.
	W20D-CV	120 120 000 8001

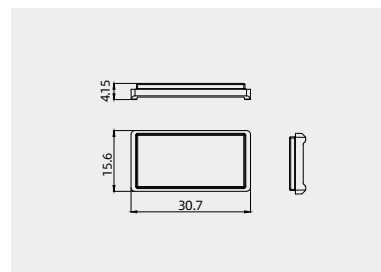

PCB Connector

6A 48

Hoods/Housings



Description	Designation	Order No.
	EMC.W20D-2TE/2SE	120 120 900 1002

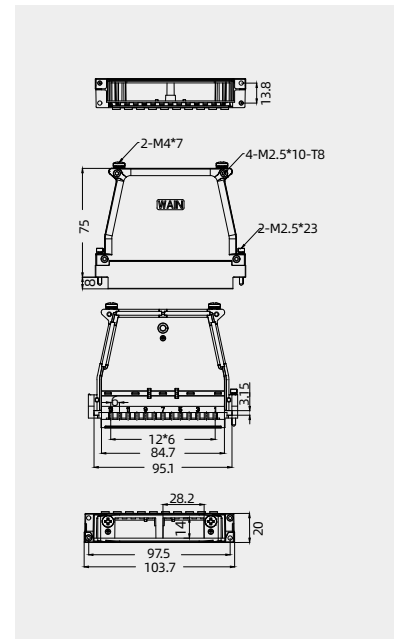

Encoding comb



Description	Designation	Order No.
	W20D-PCC	139 000 099 0500

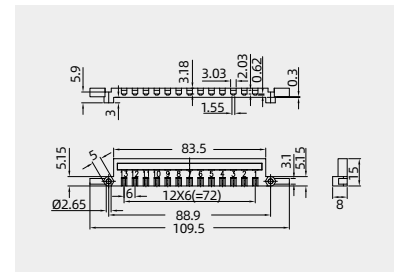

Adapter



Description	Designation	Order No.
	W20D-Code-B/L	139 000 099 0501
	W20D-Code-B/R	139 000 099 0502

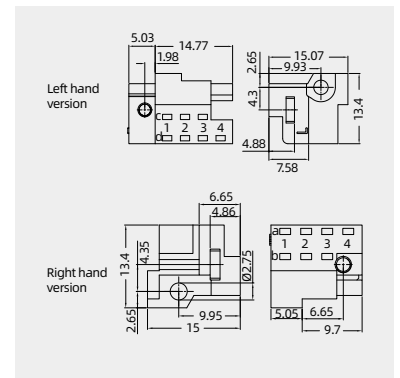

PCB Connector

6A 48

Coding pin



Description	Designation	Order No.
	CODE-W	198 002 005 0037

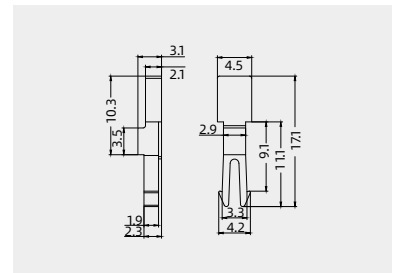

Coding pin



Description	Designation	Order No.
	CODE-F	198 002 005 0040

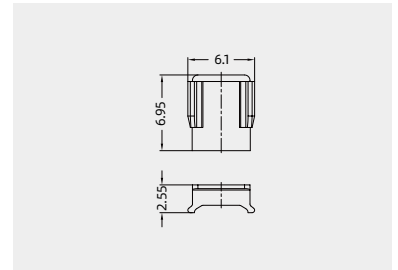



Contacts

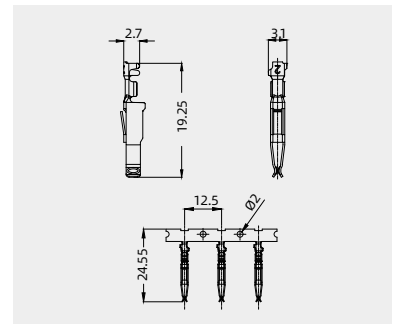

Description	Designation	Order No.
	CBGF-0.5P	101 040 202 0551

2500pcs/roll



Rail transportation industry EC series 



# Rail transportation industry EC series

## Technical characteristics

Specifications	DIN EN 60 664 DIN EN 61 984
Approvals	
Inserts	
Number of contacts	3
Electrical data acc. to EN 61 984	
without adapter	
-Rated current	650A
-Rated voltage	2000V
-Rated impulse voltage	12kV
-Pollution degree	3
Insulation resistanc	$\geq 10^{10}\Omega$
Material	polyamide
Limiting temperatures	-40°C ...+125°C
Flammability acc. to UL 94	V0
Mechanical working life(mating cycles)	$\geq 500$
Contacts	
Material	copper alloy
Surface	hard-silver plated
Contact resistance	$\leq 0.3m\Omega$
Crimp terminal	
-mm <sup>2</sup>	240mm <sup>2</sup>
Pressing force requirement	130kN
Frame	
Material	stainless steel
M4 Fixing screws	1.5N·m
M6 Fixing screws	4N·m

Inserts	
Number of contacts	4
Electrical data acc. to EN 61 984	
without adapter	
-Rated current	350A
-Rated voltage	2000V
-Rated impulse voltage	12kV
-Pollution degree	3
Insulation resistance	$\geq 10^{10}\Omega$
Material polyamide	polyamide
Limiting temperatures	-40°C ...+125°C
Flammability acc. to UL 94 V0	V0
Mechanical working life(mating cycles)	$\geq 500$
Contacts	
Material	copper alloy
Surface	hard-silver plated
Contact resistance	$\leq 0.3m\Omega$
Crimp terminal	
-mm <sup>2</sup>	35 - 120 mm <sup>2</sup>
Crimp dies	acc. to DIN 46 235
Pressing force	130 kN
Frame	
Material	stainless steel
M4 Fixing screws	1.5N·m
M6 Fixing screws	4N·m

Rail transportation industry EC

Degree of protection: IP68/IP69K

Hoods/Housings

housings



Describe	Designation	Order No.
	HP24B/EC-CCTH-2H	113 024 720 1500

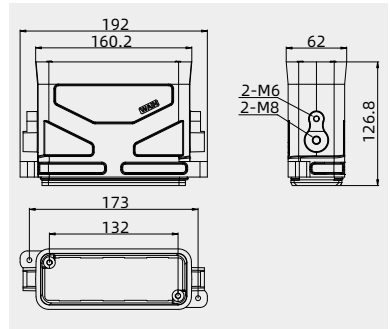

Cover



Thread	Designation	Order No.
3M32	HP24B/EC-MCV-3M32	113 024 160 1500
3M25	HP24B/EC-MCV-3M25	113 024 160 1501
4M25	HP24B/EC-MCV-4M25	113 024 160 1502

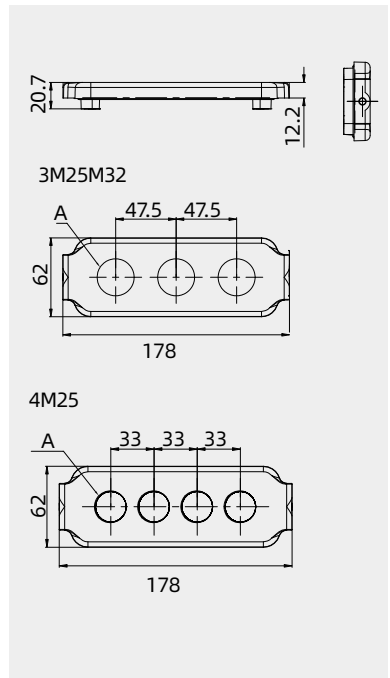

Mounting bracket



Connect way	Designation	Order No.
	HP/EC-MP/L	113 024 090 1500

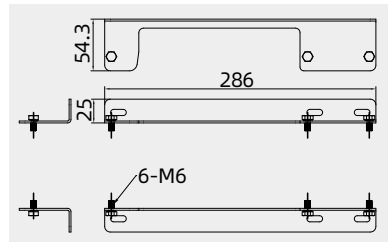



## Frame

### 3pins HC350



Describe	Designation	Order No.
Male	HF24B-003R/EC-M	113 024 930 1503
Female	HF24B-003R/EC-F	113 024 930 1500

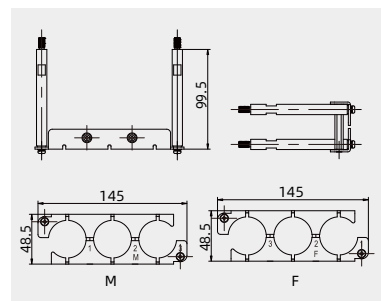

### 4pins HC350



Describe	Designation	Order No.
Male	HF24B-004C/EC-M	113 024 930 1501
Female	HF24B-004C/EC-F	113 024 930 1502

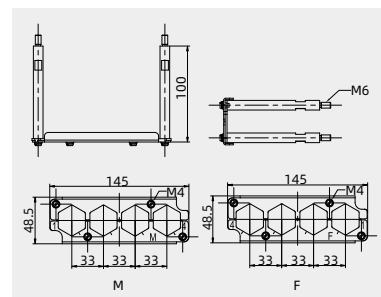

## Rail transportation industry EC

Degree of protection: IP68 ( In the case of O-rings )

### Cable gland

Cable gland



Thread	Designation	Order No.
M25	WNAC/EC-M25(D9-17)	102 117 028 1500

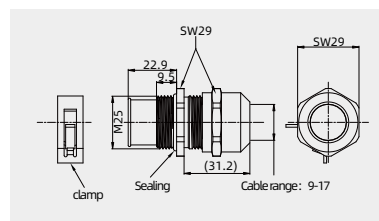

Cable gland



Thread	Designation	Order No.
M32	WNAC/EC-M32(D16-28)	102 117 029 1502

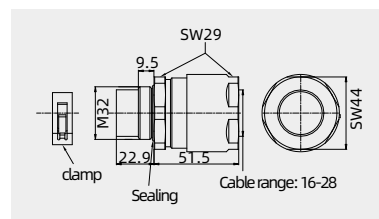

Cable gland



Thread	Designation	Order No.
M40	WNAC/EC-M40(D21-35)	102 117 030 1502

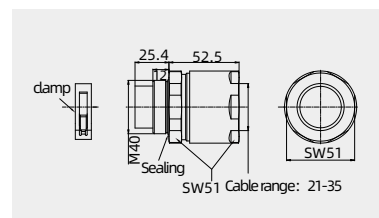

## HC-350 Heavy-current inserts

2000/4000V 350A



### Inserts

Hoods/Housings: size Pressure tight hoods/housings, please find the details on page 12-12~12-19.

#### Crimp terminal

Order crimp contacts separately



Insert	Designation	Order No.
Male	HC350-MC	131 001 010 0101
Female	HC350-FC	131 001 020 0101

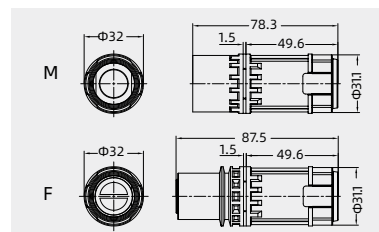

### Crimp contacts

#### Crimp contacts 350A

Silver plated



NO.	Male	Order No.	Female	Order No.
①	CHSM350-35	101 029 110 1701	CHSF350-35G	101 029 120 1703
②	CHSM350-50	101 029 110 1801	CHSF350-50G	101 029 120 1803
③	CHSM350-70	101 029 110 1901	CHSF350-70G	101 029 120 1903
④	CHSM350-95	101 029 110 2001	CHSF350-95G	101 029 120 2003
⑤	CHSM350-120	101 029 110 2101	CHSF350-120G	101 029 120 2103

For stranded wire acc. to IEC 60 228-5  
Crimp zone acc. to DIN 46 235

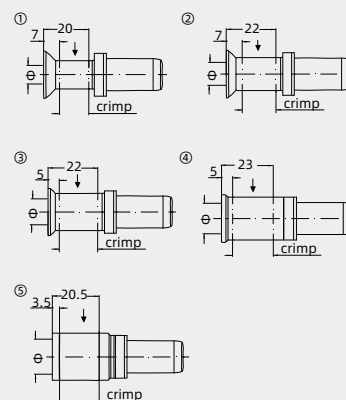

NO.	Wire gauge	Φ	Stripping length
①	35 mm <sup>2</sup>	8.2 mm	26 mm
②	50 mm <sup>2</sup>	10.0 mm	28 mm
③	70 mm <sup>2</sup>	11.5 mm	28 mm
④	95 mm <sup>2</sup>	13.5 mm	30 mm
⑤	120 mm <sup>2</sup>	15.5 mm	24 mm

#### Tools

Manual hydraulic clamp



Wire gauge	Designation	Order No.
10-240mm <sup>2</sup>	TL05	198 001 001 0005

#### Hexagonal adapter [optional]

metal version  
with O-Ring



Describe	Designation	Order No.
for 350 Hoods/Housings	WNSC-M25M25/APT	102 103 018 1001
	WNSC-M32M32/APT	102 103 019 1001

	WNSC-M25M25/APT	WNSC-M32M32/APT
Thread(LG)	M25x1.5	M32x1.5
Thread(AG)	M25x1.5	M32x1.5
length of thread(L1)	13.5	16.5
length of thread(L2)	5.5	5.5
Wrench Size(SW)	30	40

Notes: The tools for crimp terminal may influence the product quality and stability. Please select the tools recognized by our company.

## HC-650 Heavy-current inserts

4000V 650A

### Inserts

Hoods/Housings: size Pressure tight hoods/housings, please find the details on page 12-24-12-26.

#### Crimp terminal

Order crimp contacts separately



Insert	Designation	Order No.
Male	HC650-MC	131 001 010 0201
Female	HC650-FC	131 001 020 0201

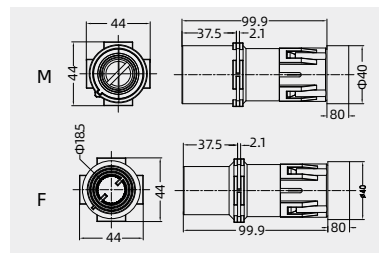

### Crimp contacts 650A (with crown spring), for HC650 inserts.

Contact resistance  $\leq 0.3m\Omega$

silver plated



NO.	Male	Order No.	Female	Order No.
①	CHSM650-95	101 030 110 2002	CHSF650-95G	101 030 120 2002
①	CHSM650-120	101 030 110 2101	CHSF650-120G	101 030 120 2101
①	CHSM650-150	101 030 110 2202	CHSF650-150G	101 030 120 2202
②	CHSM650-185	101 030 110 2301	CHSF650-185G	101 030 120 2303
②	CHSM650-240	101 030 110 2401	CHSF650-240G	101 030 120 2403

For stranded wire acc. to IEC 60 228-5  
Crimp zone acc. to DIN 46 235

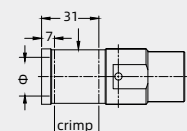
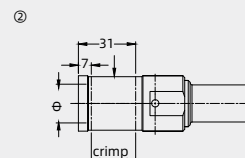
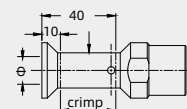
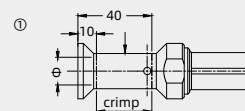

#### Tools

Manual hydraulic clamp



Wire gauge	Designation	Order No.
10-240mm <sup>2</sup>	TL05	198 001 001 0005

NO.	Wire gauge	Φ	Stripping length
①	95 mm <sup>2</sup>	13.5 mm	42 mm
	120 mm <sup>2</sup>	15.5 mm	42 mm
	150 mm <sup>2</sup>	17 mm	42 mm
②	185 mm <sup>2</sup>	19.4 mm	46 mm
	240 mm <sup>2</sup>	22.5 mm	46 mm

Notes: The tools for crimp terminal may influence the product quality and stability. Please select the tools recognized by our company.



High temperature series 



# High temperature Series

## Technical specification

Specifications	DIN EN 60 664 DIN EN 61 984
Approvals	
Inserts	
Number of contacts	6,10,16,24+PE
-Rated current	16A
-Rated voltage	500V
-Rated impulse voltage	6KV
-Pollution degree	3
Material	Liquid crystal polymer
Limiting temperatures	-40°C ...+200°C
Flammability acc. to UL 94	V0
Mechanical working life(mating cycles)	≥ 500
Colour	cream-yellow
<b>Contacts</b>	
Termination	screw
Contact resistance	≤ 1mΩ
Material	copper alloy
Surface	hard-silver plated
Wire gauge	0.75-2.5mm <sup>2</sup> (18-14 AWG)
Stripping length	7.0mm
<b>Hoods/Housings</b>	
Material	aluminium die-cast
Limiting temperatures	-40°C ...+200°C
Degree of protection	IP67(Acc. to IEC60529 for coupled connector)

## Current carrying capacity

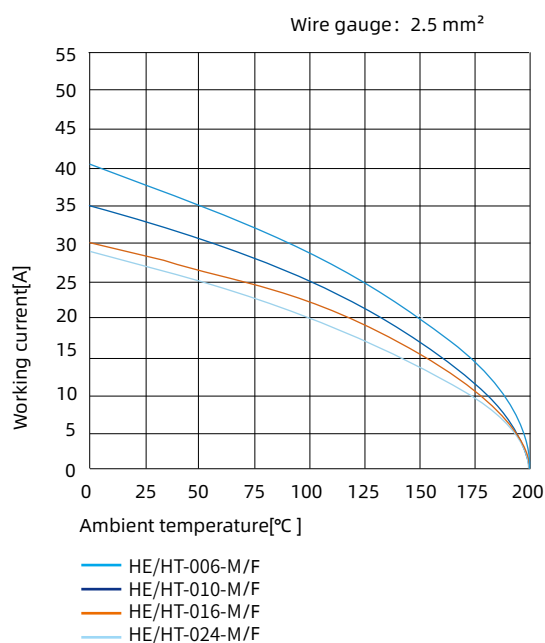

# HE High temperature inserts

500V 16A 6+

## Inserts

### Screw terminal



Insert	Designation	Order No.
Male	HE/HT-006-M	122 006 011 2500
Female	HE/HT-006-F	122 006 021 2500

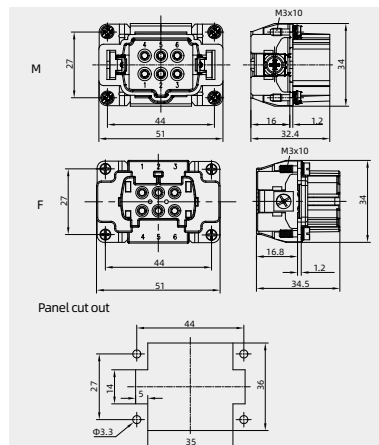

### Screw terminal



Insert	Designation	Order No.
Male	HE/HT-010-M	122 010 011 2500
Female	HE/HT-010-F	122 010 021 2500

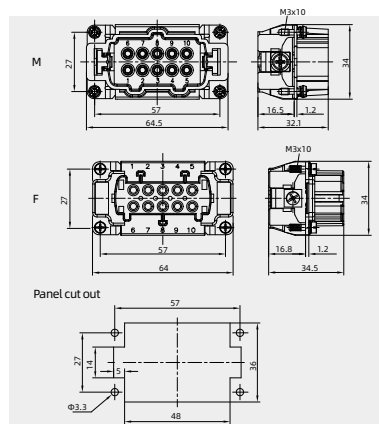

### Screw terminal



Insert	Designation	Order No.
Male	HE/HT-016-M	122 016 011 2502
Female	HE/HT-016-F	122 016 021 2502

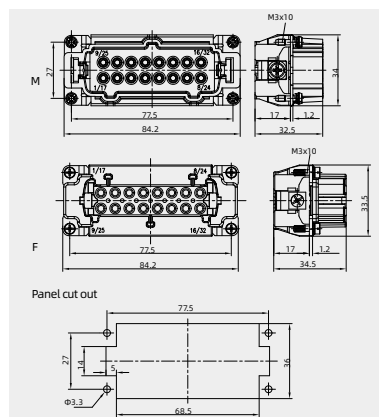

### Screw terminal



Insert	Designation	Order No.
Male	HE/HT-024-M	122 024 011 2503
Female	HE/HT-024-F	122 024 021 2503

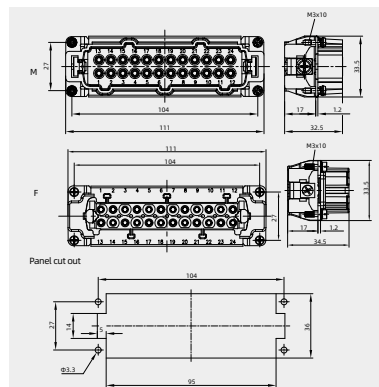



6B High temperature Metal hoods/housings

Degree of protection: IP67

Hoods, top entry



Thread	Designation	Order No.
M20	W6B/HT-TE-2B-M20	111 106 410 2500

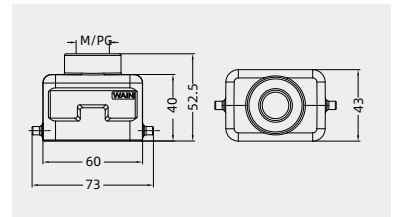

Hoods, side entry



Thread	Designation	Order No.
M20	W6B/HT-SE-2B-M20	111 106 510 2500

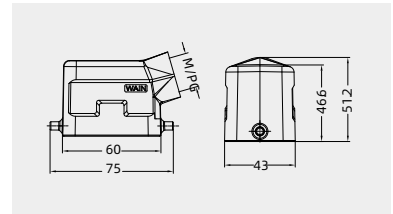

Hoods, side entry, high construction



Thread	Designation	Order No.
M25	W6B/HT-SEH-2B-M25	1111065102501
M32	W6B/HT-SEH-2B-M32	1111065102502

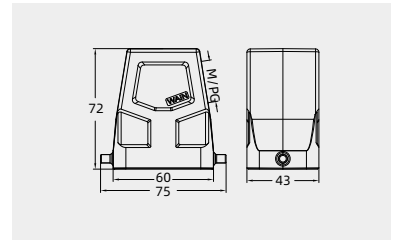

Hoods, side entry, high construction



Thread	Designation	Order No.
M25	W6B/HT-TEH-2B-M25	1111064102501
M32	W6B/HT-TEH-2B-M32	1111064102502

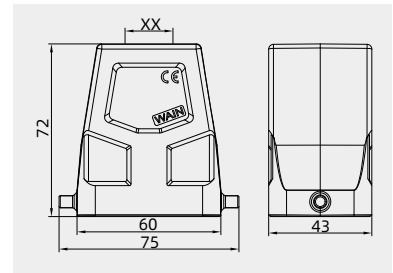

Bulkhead mounted housings



Thread	Designation	Order No.
---	W6B/HT-BK-1L/SCN	111 106 322 2500

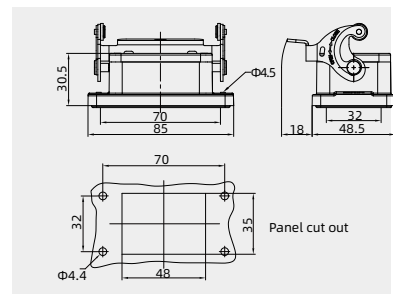

HT

10B High temperature Metal hoods/housings

Degree of protection: IP67

Hoods, top entry



Thread	Designation	Order No.
M20	W10B/HT-TE-4B-M20	111 110 430 2500

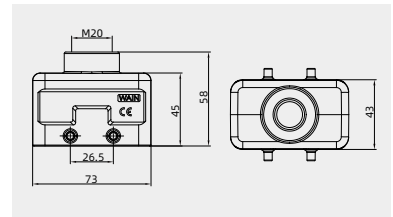

Hoods, side entry



Thread	Designation	Order No.
M20	W10B/HT-SE-4B-M20	111 110 530 2500

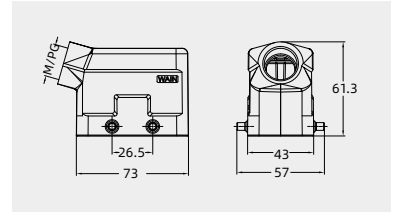

HT

Hoods, side entry, high construction



Thread	Designation	Order No.
M25	W10B/HT-SEH-4B-M25	111 110 530 2501
M32	W10B/HT-SEH-4B-M32	111 110 530 2502

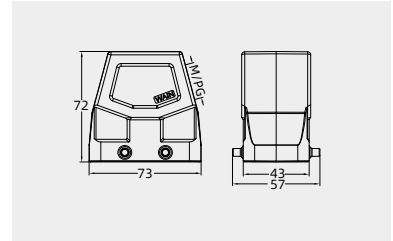

Hoods, side entry, high construction



Thread	Designation	Order No.
M25	W10B/HT-TEH-4B-M25	111 110 430 2501
M32	W10B/HT-TEH-4B-M32	111 110 430 2502

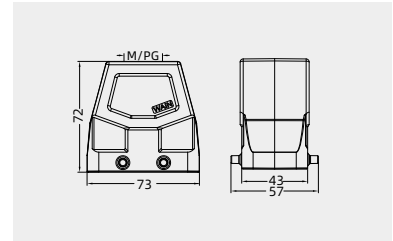

Bulkhead mounted housings



Thread	Designation	Order No.
---	W10B/HT-BK-2L/SCN	111 110 322 2500

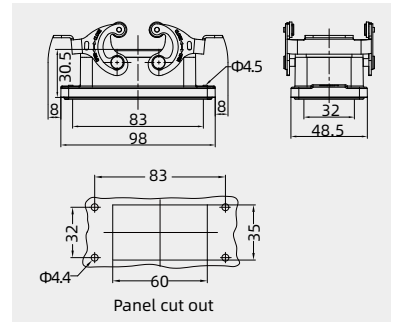

16B High temperature Metal hoods/housings

Degree of protection: IP67

Hoods, top entry



Thread	Designation	Order No.
M25	W16B/HT-TE-4B-M25	111 116 430 2500

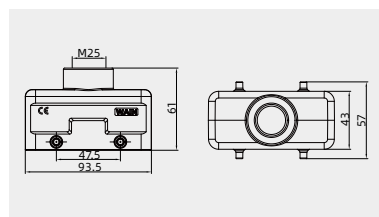

Hoods, side entry



Thread	Designation	Order No.
M25	W16B/HT-SE-4B-M25	111 116 530 2500

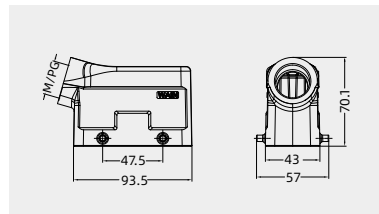

Hoods, side entry, high construction



Thread	Designation	Order No.
M32	W16B/HT-SEH-4B-M32	111 116 530 2501
M40	W16B/HT-SEH-4B-M40	111 116 530 2502

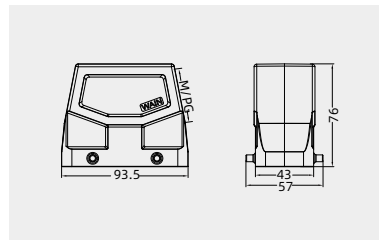

Hoods, side entry, high construction



Thread	Designation	Order No.
M32	W16B/HT-TEH-4B-M32	111 116 430 2501
M40	W16B/HT-TEH-4B-M40	111 116 430 2502

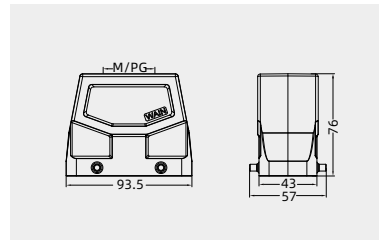

Bulkhead mounted housings



Thread	Designation	Order No.
---	W16B/HT-BK-2L/SCN	111 116 342 2500

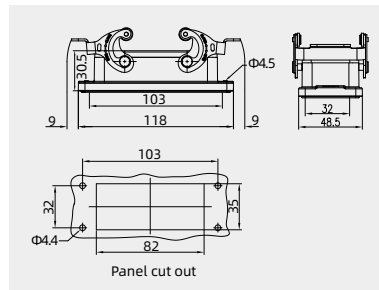

HT

24B High temperature Metal hoods/housings

Degree of protection: IP67

Hoods, top entry



Thread	Designation	Order No.
M25	W24B/HT-TE-4B-M25	111 124 430 2500

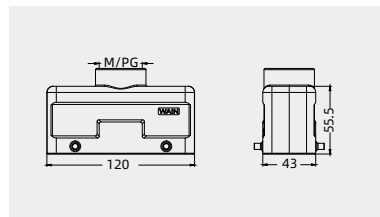

Hoods, side entry



Thread	Designation	Order No.
M25	W24B/HT-SE-4B-M25	111 124 530 2500

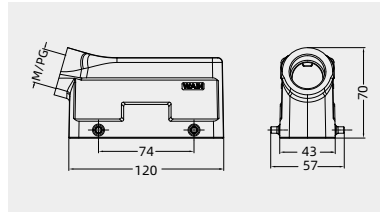

HT

Hoods, side entry, high construction



Thread	Designation	Order No.
M32	W24B/HT-SEH-4B-M32	111 124 530 2501
M40	W24B/HT-SEH-4B-M40	111 124 530 2502

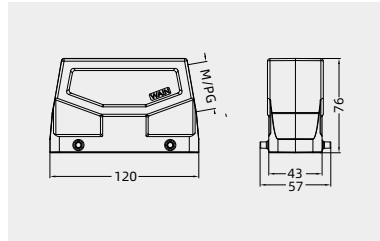

Bulkhead mounted housings



Thread	Designation	Order No.
M32	W24B/HT-TEH-4B-M32	111 124 430 2501
M40	W24B/HT-TEH-4B-M40	111 124 430 2502

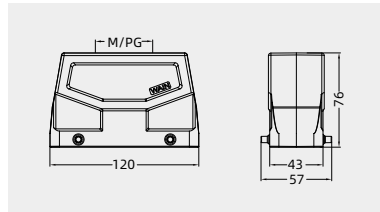

Bulkhead mounted housings



Thread	Designation	Order No.
---	W24B/HT-BK-2L/SCN	111 124 342 2500

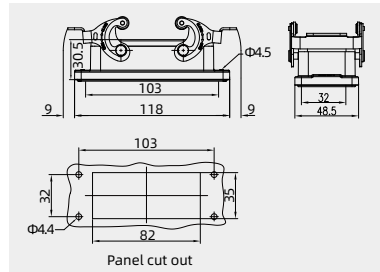



# Circular connector



C

## Contents

Series	Rated voltage	Rated current	Number of contacts	Terminal	Page
Technical characteristics					P16-02 ~ P16-10
M8	30V,60V	4A	3,4,5	screw clamp connection, solder, dip solder, moulded	P17-01 ~ P17-22
M12-A	60V, 125V, 250V	2A, 4A, 8A	3,4,5,8,12	screw clamp connection, solder, dip solder, moulded, single wires	P18-01 ~ P18-41
M12-B	125V, 250V	4A, 8A	2,3,4,5	screw clamp connection, solder, dip solder, moulded, single wires	P18B-01 ~ P18B-28
M12-D	250V	4A	4	screw clamp connection, solder, dip solder, moulded, single wires	P19-01 ~ P19-16
M12-S	630V	16A, 12A	3, 4	crimp terminal	P19S-01 ~ P19S-16
M12-L ★	63V	16A	5(4+PE)	screw clamp connection, solder, dip solder, moulded, single wires	P19L-01 ~ P19L-10
M12-X	250V	4A	8	crimp terminal, single wires	P19X-01 ~ P19X-08
IO-LINK Sensor junction box ★	-	-	-	-	P19K-01 ~ P19K-06
M8/M12 Distributor M8/M12 Sensor junction box	60/250V 10~30V DC	4A 2A, 9A	4,5 4,5	- pluggable M23	P20-01 ~ P20-05
7/8	300V	8A, 9A, 10A, 12A	3(2+PE),4(3+PE),5(4+PE)	screw clamp connection,	P21-01 ~ P21-08
M15 ★	63V	5A	12	crimp terminal	P21Q-01 ~ P21Q-08
M17	32V, 60V, 630V	3.6A, 7A, 14A	7,12,17	crimp terminal	P21S-01 ~ P21S-11
HR23(M23)	25V~/60V-	7A, 15A	6,9,12,17,19	crimp terminal, (PCB)solder terminal screw clamp connection	P22-01 ~ P22-14
MR23	25V~/60V-	7A	12,17	crimp terminal	P23-01 ~ P23-07
M23	250V, 630V	9A, 30A	6,8	crimp terminal	P24-01~ P24-17
M40	250V	20A, 60A	4/4	crimp terminal	P25-01~ P25-05
Q38	250V	13A, 30A	12+19, 32 (28+4), 48	Quick connect card slot	P25Q-01~ P25Q-06
Power electrical connector	220V, 250V	1A, 13A, 20A, 25A, 40A	4,5,6,10,26,RJ45&3	crimp terminal, solder terminal	P26-01~ P26-08
HW	1000V	800A	1	crimp terminal	P27-01~ P27-04
MI	400/30V	6/1A	6+6(5+PE)	crimp terminal, solder terminal	P27-05~ P27-06

## • Technical data

- Binding for the applications of connectors are the requirements of the equipment specifications of the users.
- We reserve the right to change the design due to improvements in quality, further development or production requirements.
- All technical data mentioned in this catalog are related to connectors, meaning connecting devices which in normal use (when under load) shall not be inserted or withdrawn.
- Regarding the CE marking it has to be noted that electronic components such as connectors are not subject to a marking, and therefore must not be marked with a CE mark. This is confirmed by the rules of the European commission for low voltage and EMC guidelines.
- The listed technical data are intended to help selecting the appropriate product and to secure a proper application.
- The connectors are developed and designed for the use in the field of equipment, control and electrical appliances. Whether they also can be used in other applications has to be checked by the user.
- When mounting electrical conductive socket housings, they have to be integrated into the protection measures.
- The wires to be connected shall be stripped only so far that distances to conductive parts are not shortened. When wires are soldered, it has to be beared in mind that no single strands stick out and no short circuit can occur.
- All dimensions in this catalog are in mm.
- For connectors with strain relief the following minimum parameters are valid:

		Recommended tightening torque of the pressing screw
2-3	Cable $\Phi$ : min.20N	30-40 Ncm
3-4	Cable $\Phi$ : min.30N	30-40 Ncm
4-5	Cable $\Phi$ : min.40N	80-100 Ncm
5-6	Cable $\Phi$ : min.50N	80-100 Ncm
6-7	Cable $\Phi$ : min.60N	80-100 Ncm
7-8	Cable $\Phi$ : min.70N	80-100 Ncm
8-12	Cable $\Phi$ : min.80N	100-140 Ncm

### • Connectors

Connectors are components which are not to be engaged or disengaged in normal use (under live).

### • Plug and socket devices

Plug and socket devices are components which in normal use (under live or load) may be engaged or disengaged when live or under load.

## • Termination methods

### • Screw termination

A Screw termination is a detachable electrical connection between a conductor and a screw clamp. Screw clamps are designed acc. to DIN/EN 60999/VDE 0609. The chart below shows the screw size and the required clamping and testing torque.

Screw size	M2.5	M3	M3.5
Torque(Ncm) Cap screw	40	50	60
Headless screw	20	25	40

### • Solder connection

Besides the soldering of single wires with solder irons or soldering machines, the method of wave soldering or infra-red vapor phase soldering has gained great importance for connectors for printed boards or flexible wiring.

We recommend the following soldering parameters

- hand-soldering: soldering bold temperature max. 370° C/max. 4s
- dip soldering: soldering bath temperature max. 270° C/max. 4s
- alternativ dip soldering: soldering bath temperature max. 260° C/max. 10s

When wires are soldered, it has to be watched that no single strands stick out which could lead to a short circuit and that no large solder joints occur which would reduce the clearance and creepage distances unfavourably. Testing and valuation of solder joints and the relevant components is regulated in DIN EN 60068



## • Technical data

### • Crimp connection

A crimp connection is a non-detachable electrical connection between a conductor and a crimp contact produced with the crimp technology. The requirements for crimp connections are defined in DIN IEC 60352 part 2.

An important point for the quality of a crimp connection is the achieved tensile strength of the termination. Since easy to measure, the tensile strength is a practicable means for quality control purposes. The diagram below shows the required minimum tensile strength depending on the wire size.

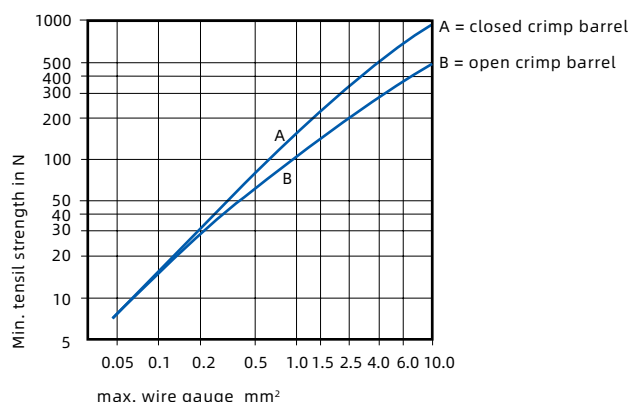

### • American Wire Gauges

Since various areas of industry are also using wires according to the American Wire Gauge (AWG), the following comparison chart is included to allow a cross reference between AWG and metric wire sizes

AWG	Wire composition (mm)	Wire-Ø(mm)	Wire gauge(mm <sup>2</sup> )
30	1 x 0.25 7 x 0.10	2-3	2-3
28	1 x 0.32 7 x 0.13	3-4	3-4
26	1 x 0.40 7 x 0.16 19 x 0.10	0.40 0.48 0.51	0.13 0.14 0.15
24	1 x 0.51 7 x 0.20 19 x 0.13	0.51 0.61 0.64	0.21 0.22 0.25
22	1 x 0.64 7 x 0.25 19 x 0.16	0.64 0.76 0.81	0.33 0.34 0.38
20	1 x 0.81 7 x 0.32 19 x 0.20	0.81 0.97 1.02	0.52 0.56 0.60
18	1 x 1.02 19 x 0.25	1.02 0.27	0.82 0.93
16	19 x 0.29	1.44	1.25
14	19 x 0.36	1.80	1.93
12	19 x 0.46	2.29	3.16
10	19 x 0.56	3.10	4.65

### • Composition and dimensions of commonly used copper wires based on VDE 0295

Wire gauge(mm <sup>2</sup> )	Wire composition (mm)	Wire-Ø(mm)
0.09	12 x 0.10	0.5
0.14	18 x 0.10	0.5
0.25	14 x 0.16 32 x 0.10	0.7 0.7
0.34	19 x 0.16 42 x 0.10	0.8 0.9
0.5	7 x 0.30 16 x 0.21 28 x 0.16	1.0 1.1 1.1
0.75	7 x 0.37 24 x 0.21 42 x 0.16	1.2 1.2 1.3
1.0	7 x 0.43 32 x 0.21 56 x 0.16	1.4 1.4 1.5
1.5	7 x 0.52 30 x 0.26 84 x 0.16	1.6 1.7 1.8
2.5	7 x 0.67 50 x 0.26 140 x 0.16	2.2 2.3 2.3
4.0	7 x 0.85 56 x 0.31 224 x 0.16	2.7 2.8 2.9

It has to be noted that wires of the same AWG number but with different composition have slightly different mm<sup>2</sup>!

## • Hoods/housings connector insert protection

For safety reasons, connectors have to be protected from outside influences like dust, foreign objects, direct contact, moisture and water. This protection is provided on industrial connectors by their housings with their latching devices and sealed cable entries. The degree of protection can be selected depending on the type of intended use. The standard IEC 60529 and/or DIN EN 60529 has specified and divided the degree of protection into several classes.

The degree of protection is indicated in the following way:

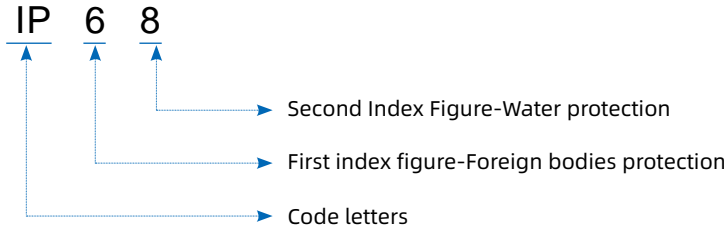

Index figure	Degree of protection	Index figure	Degree of protection
0	No protection: No protection against accidental contact, no protection against solid foreign bodies	0	No protection against water
1	Protection against large foreign bodies: Protection against contact with any large area by hand and against large solid foreign bodies with $\varnothing > 50$ mm	1	Drip-proof: Protection against vertical water drips
2	Protection against medium sized foreign bodies: Protection against contact with the fingers, protection against solid foreign bodies with $\varnothing > 12$ mm	2	Drip-proof: Protection against water drips (up to a $15^\circ$ angle)
3	Protection against small solid foreign bodies: Protection against tools, wires or similar objects with $\varnothing > 2.5$ mm, protection against small foreign solid bodies with $\varnothing > 2.5$ mm	3	Spray-proof: Protection against diagonal water drips (up to a $60^\circ$ angle)
4	Protection against grain-shaped foreign bodies: As 3 however $\varnothing > 1$ mm	4	Spray-proof: Protection against splashed water from all directions
5	Protection against injurious deposits of dust: Full protection against contact. Protection against interior injurious dust deposits	5	Hose-proof: Protection against water (out of a nozzle) from all directions
6	Protection against ingress of dust: Total protection against contact. Protection against penetration of dust	6	Strong hose-proof: Protection against strong water (out of a nozzle) from all directions
		7	Protected against immersion: Protected against temporary immersion
		8	Water-tight: Protected against water pressure

## • Electrotechnical information

### • Voltage grading of connectors (insulation coordination)

Clearances and creepage distances are the base of voltage grading of connectors. Valuation and dimensioning of clearances and creepage distances have changed since the introduction of insulation coordination. The following standards apply for this:

- IEC 60664-1/11.92 Insulation coordination for equipment within low-voltage systems
- DIN VDE 0110/4.97 Insulation coordination for equipment within low-voltage systems

Insulation coordination comprises the selection of the electrical insulation performances of an equipment (e.g. connector), taking into account the expected use and its environment.

#### • In this respect some definitions are explained in short:

**Rated voltage:** The value of voltage assigned by the manufacturer to the connector and to which operation and performance characteristics are referred.

**Rated impulse voltage:** The value of an impulse withstand voltage assigned by the manufacturer to the connector characterising the specified withstand capability of its insulation against transient overvoltages.

**Clearance:** The shortest distance in air between two conductive parts.

**Creepage distance:** The shortest distance along the surface of the insulating material between two conductive parts.



### • Voltage grading of connectors (insulation coordination)

**Overvoltage categories:** The standard has divided the possible overvoltages into four categories. The three categories which relate to connectors are shortly described below:

#### Overvoltage category I

Equipment (e.g. connectors) intended for the use in applications or parts of installations in which no overvoltage can occur. Examples are low voltage equipments.

#### Overvoltage category II

Equipment (e.g. connectors) intended for the use in installations or parts of it, in which lightning overvoltages do not need to be considered, however switching overvoltages generated by the equipment. Examples are household appliances.

#### Overvoltage category III

Equipment (e.g. connectors) intended for the use in installations or parts of it in which lightning overvoltages do not need to be considered, however switching overvoltages generated by the equipment, and for cases where the reliability and the availability of the equipment (e.g. connectors) or its dependent circuits are subject to special requirements. Examples are protecting means, switches and sockets.

#### Material groups

For the dimensioning of the creepage distance, the tracking formation of the insulating material used by the manufacturer has to be considered. The materials are separated into three groups according to their CTI values (Comparative Tracking Index):

Material group I  $600 \leq \text{CTI}$

Material group II  $400 \leq \text{CTI} < 600$

Material group III  $175 \leq \text{CTI} < 400$

### • Pollution degree of connectors

**Pollution degree:** The expected pollution around the equipment (e.g. connector) was established in the standard in four degrees:

**Pollution degree 1:** No pollution or only dry, non-conductive pollution occurs. The pollution has no influence. Examples: The inside of electrical measuring instruments, electronic measuring devices.

**Pollution degree 2:** Only non-conductive pollution occurs. Except that occasionally a temporary conductivity caused by condensation is to be expected.

Examples: Household appliances, installation material, lamps, power supplies of office equipment.

**Pollution degree 3:** Conductive pollution occurs or dry non-conductive pollution occurs which becomes conductive due to condensation which is to be expected.

Examples: Electrical equipment of machine tools and processing machines, low voltage switches at machine tools.

**Pollution degree 4:** The pollution generates persistent conductivity caused by conductive dust or by rain or snow.

Examples: Equipment on wagon roofs and beneath wagons at electrical locomotives, rail cars, trolley busses. Equipment at electrical locomotives underground.

**Additional remarks:** If connectors being defined for pollution degree 1 and overvoltage categorie 1 are applied for other conditions (higher pollution degree and higher overvoltage category), voltage levels reduce correspondingly. But the connectors can be used without any problems at reduced maximum voltages.

It has to be noted that for a connector with a degree of protection of at least IP 54 the parts inside the enclosure may be dimensioned for a lower pollution degree. This also applies to mated connectors whose enclosure is ensured through the connector housing and which may only be disengaged for test and maintenance purposes.

## • Current carrying capacity

The current carrying capacity of a connector denotes the current that can be carried continuously and simultaneously through all its contacts. It is determined by testing following the standard DIN IEC 60512.

The upper limit temperature results from the thermal properties of the contact and insulating materials. The sum of the ambient temperature and the temperature created by the current flow may not exceed the upper limit temperature of the connector.

This means, that the current carrying capacity is no fixed value but decreases with increasing ambient temperatures. This relation between current, the caused temperature rise and ambient temperature of the connector is depicted in a curve, the so-called derating curve. As one can see, the current carrying capacity decreases with increasing ambient temperature.

On the other hand, very often not all contacts are loaded simultaneously with the whole rated current, so that some single contacts can carry a higher current than that according to the derating curve. These currents have to be determined by testing.

### Derating curve:

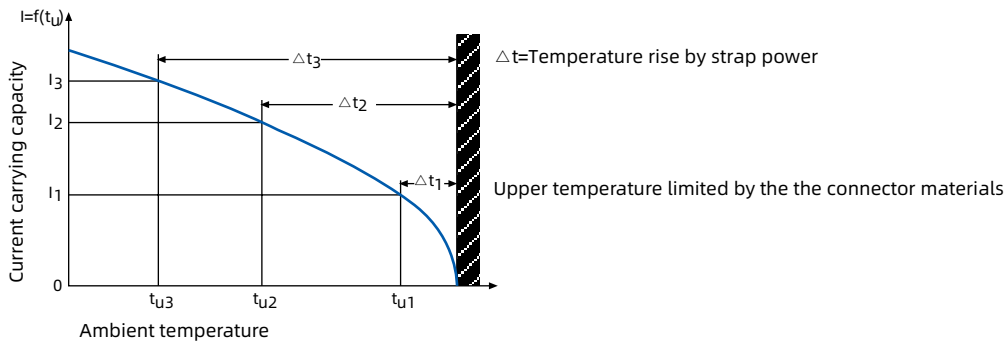

## • Shielding, Electromagnetic compatibility (EMC)

Since the issue of the German law about electromagnetic compatibility of equipment, more attention is paid to EMC within the concerned equipment.

The equipment has to be designed in such a way that:

1. the generation of electromagnetic interference is limited to such extend that the determined operation of this equipment is not hampered,
2. the equipment has a reasonable resistance against electromagnetic interference so that the determined operation is not hampered.

To satisfy the requirements of the equipment manufacturers, more and more connectors with shielding properties are applied where shielded cables can be connected. In use are conductive housings to which the cable shield can be terminated. In case of circular connectors, it should be watched that the cable shield is carefully connected to the connector shield. A circumferentially (360°) contact is optimal in this case. Good shielding values (and very often sufficient for practical use) are also achieved when the shielding braid is firmly connected to the conductive housing. Not sufficient are fully plastic connectors without metal sleeves with no possibility to terminate the cable shield.

Furthermore, it is important that during mating a secure electrical connection between plug and socket housing is achieved and that the panel mounted connector part has a good metallic connection with the chassis wall.

The shielding attenuation is stated in decibel (db) and depends on the frequency. Good shieldings have a high attenuation, which over a large frequency band (MHz) does not decrease too heavily.

Attenuation curve acc. to DIN 47250-6  
Example 360° shielding: M12-A series

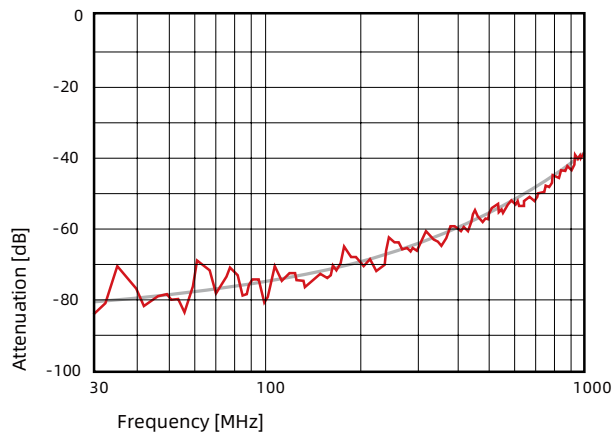

## • Information about used materials

Two material groups are used to manufacture the connectors described in this catalog:

- 1: Metals for contacts and housings
- 2: Plastic material for inserts and housings

Materials for contacts

The properties of contacts are defined to a large extent by the used materials. Decisive features are:

- strength and spring properties
- electrical conductivity
- max. operating temperature

Considering these points, Wain is using proven copper-alloys for the manufacture of contacts;

### Materials for metal housings

Depending on the application, the metal housings are produced from either brass, zinc die-cast or an aluminium alloy. For circular housing parts, mainly brass is used due to its good machine ability and strength. For angled housings and parts with minor finishing work, zinc diecast or an aluminium alloy is used.

### Plastic material for inserts

The inserts of Wain-connectors are manufactured primarily from PBT (Polybutylen-terephthalate), a plastic material with a temperature stability of up to 130 °C and special properties for high grade moulded parts. The material has very good chemical and electrical properties and very good dimensional stability.

### Surface finishes

In order to protect contacts and housings from aggressive environments and to improve the conductivity, the surfaces are treated accordingly. At wain, contacts are gold or silver plated. These platings improve the conductivity and are very corrosion-proof. For applications in the mA-range at very low voltages, gold plated contacts are recommended to improve the electrical properties and in addition, it increases the corrosion-proofness. Housings are anodised or covered with a plating of either nickel or chromium for anti-corrosion and decorative reasons.

### Material for sealing gaskets

To achieve the required protection class, all Wain circular connectors are equipped with sealing rings of an elastomeric material. Depending on the final use, wain has selected Chloroprene Rubber (Trademark Neoprene), Nitrid Rubber (Trademark Perbunan) or Fluorsilicon Rubber (Trademark Viton). The chemical resistance of these elastomeric materials can be depicted from table on page 16-09.

### Plastic material for housings

Plastic housings are primarily manufactured from PA (Polyamide). This wellproven material (internationally known under the name Nylon) is very tough, non-abrasive, resistant against solvents, oils and greases and can be used at temperatures up to 120 °C.

## • Important data of used metals

Material	Letter symbol	Conductivity ( $\frac{m}{\Omega \times mm^2}$ )	Tensile strength (N/mm <sup>2</sup> )	Limit temperature (°C)	Corrosion resistance <sup>1)</sup>
Coatings					
Gold	Au	44	-	-	Very good
Silver	Ag	62	-	-	Good
Nickel	Ni	10	-	-	Very good
Optaloy	CuSnZn	15	-	-	Good
Basic material					
Copper	Cu	55	ca.400	90	Partially resistant. Surface coating recommended.
Brass	CuZn	15	ca.500	90	Partially resistant. Surface coating recommended.
Phos. bronze	CuSn	9	ca.700	120	Good
Zinc die-cast	GD-Zn	16	ca.300	-	Non-resistant. Surface coating required.
Aluminium die-cast	GD-Al	20	ca.250	-	Partially resistant. Surface coating recommended.

1) Depends on environmental influences.

- Information about used materials

- Chemical resistance of used plastic material and elastomeres

	PA	PBT	CR	NBR	FPM	PUR(Ester) <sup>1)</sup>	PUR(Ether) <sup>1)</sup>
<b>Hydrocarbons</b>							
Gasolin	+	+	0	+	+	+	+
Fuel oil	+	+	+	+	+	+	+
Benzole	+	0	-	-	+	0	0
Naphthalene	+	0	-	+	+	0	0
<b>Alcohols</b>							
Ethyl alcohol	0	+	+	+	+	+	+
Isopropanol	0	0	+	+	+	+	+
Glycol	-	0	+	+	+	+	+
Glycerine	+	+	+	+	0	+	+
<b>Ketons</b>							
Acetone	+	+	0	-	-	-	-
<b>Acids</b>							
Hydrochloric acid(20% )	-	0	0	0	+	-	+
Nitric acid(10% )	-	0	0	0	+	-	-
Phosphoric acid(30% )	-	0	+	+	+	-	+
Sulphuric(30% )	-	0	+	+	+	-	+
Citric acid(10% )	+	+	+	+	+	0/-w	+
Lactic acid(10% )	+	+	0	0	+	0/-	+
Acetic acid(10% )	0	0	+	+	+	0/-	+
<b>Bases (solutions)</b>							
Caustic soda(10% )	+	-	0	0	0	0	+
Ammonia, diluted	+	+	+	+	+	-	+
<b>Oils, greases</b>							
Soybean oil	+	+	+	+	0	0/-	0
Olive oil	+	+	+	+	+	0/-	0
Butter	+	+	+	+	+	0/-	0/-
Salt water	+	+	+	+	+	0	+
<b>Cleaning agents</b>							
Detergents	+	0	+	+	+	+/-	+/-
Detergents	+	+	+	+	+	+/-	+/-

## • Information to used standards

- The standards used in this catalog for definition and testing of the connectors are described below in more detail. These are:

### IEC 60664-1; (2007-4), Insulation coordination

This international standard, which is identical to the German standard DIN VDE 0110-1 issued April 1997, is a basic safety standard to achieve insulation coordination. It provides the information necessary to specify clearances, creepage distances and solid insulation for electrical equipment (e.g. connectors), taking into account the expected micro-environment and other influencing stresses to which it is likely to be subjected during its anticipated lifetime. Included are methods for voltage testing in regards to the insulation coordination.

### IEC 60512; (2001-1), Testing procedures and measuring methods

This international standard, which is identical with the European standard DIN EN 60512, has replaced the earlier German standard DIN 41640. It is the basic standard for testing procedures and measuring methods for electromechanical components (e.g. connectors). The standard is very comprehensive and consists of nine parts in total in which all electrical, mechanical and climatic tests are described. Furthermore, it contains tests about solderability, sealing, shielding and cable strain relieve.

### IEC 60529; (2001-2), Degrees of protection provided by enclosures (IP-Code)

This international standard, which is identical with the European standard DIN EN 60529 and the German standard DIN VDE 0470-1 of Nov. 1992, defines the designation, requirements and testing for the classification of degrees of protection by enclosures for electrical equipment (e.g. connectors). It classifies the protection against access to hazardous parts, protection against foreign objects and protection against ingress of water. The degree of protection is indicated by an IP-Code.

### IEC 60068-1; March 1995, Environmental testing

This international standard, which is identical with the European standard DIN EN 60068, contains basic procedures for environmental tests and test severities. The test procedures are intended to prove the resistance of components against expected environmental influences under working conditions. Typical tests are: cold, dry and damp heat, shock, vibration, temperature change and more.

### DIN EN 61984 (VDE 0627); 2009-11, Connectors and Connection devices

This international standard is applicable for plug connectors with rated voltages ranging from 50 V to 1000 V AC and DC and rated currents up to 500 A per contact for which there is either no detail specification (DS), or if the detail specification with reference to the safety requirements is based on this standard. This standard may be used as a guide for plug connector with rated voltages up to 50 V. In this case the design for clearances and leakage paths must be based on IEC 60664-1.

This standard may also be used as a guide for plug connectors with rated voltages greater than 125 V per pole.

This standard is not applicable for plug connectors in or on equipment for which there are application-specific safety requirements for plug connectors.

## M8 Circular connectors

Standards: IEC-61076-2-104



- **Cable Connector**
  - Versions with assembly
  - Thread locking M8x1
  - Screw-, solder termination
  - Connector moulded on cable
  - Degree of protection IP67/IP65 1)
  - Cable length 2m and 5m (PVC and PUR)
  - Further Cable length upon request, minimum order quantity 200 pieces
- **Cable Connector shielded**
  - Assembly possible, moulded on cable
  - Thread locking M8x1
  - Solder-, screw termination



## M8 Circular Connector

30/60V 4A

## Technical characteristics

	3-pole	4-pole
Rated current(40°C )	4A	4A
Rated voltage	60V	30V
Rated impulse voltage	800V	800V
Pollution degree	3	3
Overvoltage categorie	II	II
Contact resistance	≤ 10 mΩ	≤ 10 mΩ
Connector locking system	screw	screw
Termination	screw, solder	screw, solder
Wire gauge	screw 0.14-0.5mm <sup>2</sup> (AWG26-20) ,solder 0.25mm <sup>2</sup> (AWG24)	screw 0.14-0.5mm <sup>2</sup> (AWG26-20) ,solder 0.25mm <sup>2</sup> (AWG24)
Cable outlet	3.5-5 mm	3.5-5 mm
Degree of protection	IP67	IP67
Mechanical operation	> 100	> 100
Limiting temperature	-40°C ...+85°C	-40°C ...+85°C
Material group	III	III
Material of contact	copper alloy	copper alloy
Contact plating	Au	Au
Insulating material	PA	PA
Material of housing	PA	PA

## Straight cable connectors

## Male cable connector, solder



## Contact arrangements



Contacts	Cable outlet	Designation	Order No.
3	3.5-5 mm	M8-MST03-T-D5	162 003 413 3001
4	3.5-5 mm	M8-MST04-T-D5	162 004 413 3001

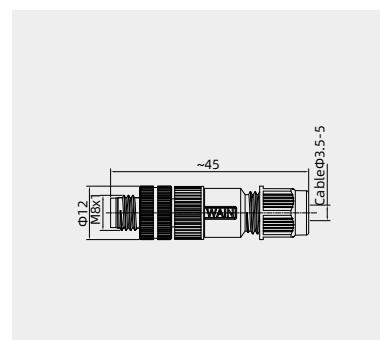

## Male cable connector, screw

## Recommend to use



## Contact arrangements



Contacts	Cable outlet	Designation	Order No.
3	3.5-5 mm	M8-M03-T-D5	162 003 411 3001
4	3.5-5 mm	M8-M04-T-D5	162 004 411 3001

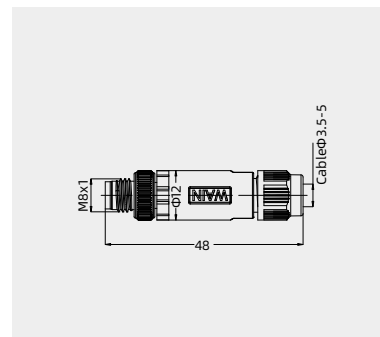

M8

## M8 Circular Connector

30/60V 4A

## Technical characteristics

	3-pole	4-pole
Rated current(40°C )	4A	4A
Rated voltage	60V	30V
Rated impulse voltage	800V	800V
Pollution degree	3	3
Overvoltage categorie	II	II
Contact resistance	≤ 10 mΩ	≤ 10 mΩ
Connector locking system	screw	screw
Termination	screw, solder	screw, solder
Wire gauge	screw0.14-0.5mm <sup>2</sup> (AWG26-20),solder 0.25mm <sup>2</sup> (AWG24)	screw0.14-0.5mm <sup>2</sup> (AWG26-20),solder 0.25mm <sup>2</sup> (AWG24)
Cable outlet	3.5-5 mm,3.5-5.5 mm	3.5-5 mm,3.5-5.5 mm
Degree of protection	IP67	IP67
Mechanical operation	> 100	> 100
Limiting temperature	-40°C ...+85°C	-40°C ...+85°C
Material group	III	III
Material of contact	copper alloy	copper alloy
Contact plating	Au	Au
Insulating material	PA	PA
Material of housing	CuZn	CuZn

## Straight cable connectors,shielded

Male cable connector, solder, shielded

Recommend to use

Contacts	Cable outlet	Designation	Order No.
3	3.5-5 mm	M8-MST03-T-D5-SH	162 003 413 2001
4	3.5-5 mm	M8-MST04-T-D5-SH	162 004 413 2001



Contact arrangements



3pin

4pin

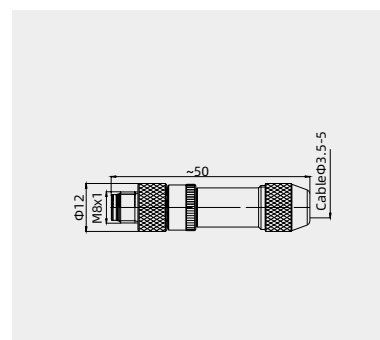

Male cable connector, screw, shielded

Contacts	Cable outlet	Designation	Order No.
3	3.5-5 mm	M8-M03-T-D5.5-SH	162 003 411 2001
4	3.5-5 mm	M8-M04-T-D5.5-SH	162 004 411 2001



Contact arrangements



3pin

4pin

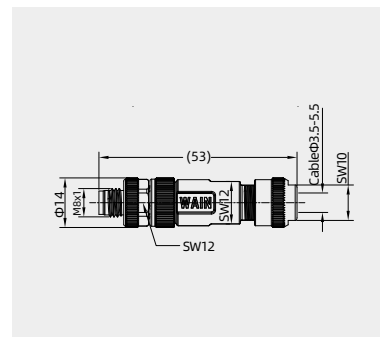

## M8 Circular Connector

30/60V 4A

## Technical characteristics

	3-pole	4-pole
Rated current(40°C )	4A	4A
Rated voltage	60V	30V
Rated impulse voltage	800V	800V
Pollution degree	3	3
Overvoltage categorie	II	II
Contact resistance	≤ 10 mΩ	≤ 10 mΩ
Connector locking system	screw	screw
Termination	screw, solder	screw, solder
Wire gauge	screw 0.14-0.5mm <sup>2</sup> (AWG26-20) ,solder 0.25mm <sup>2</sup> (AWG24)	screw 0.14-0.5mm <sup>2</sup> (AWG26-20) ,solder 0.25mm <sup>2</sup> (AWG24)
Cable outlet	3.5-5 mm	3.5-5 mm
Degree of protection	IP67	IP67
Mechanical operation	> 100	> 100
Limiting temperature	-40°C ...+85°C	-40°C ...+85°C
Material group	III	III
Material of contact	copper alloy	copper alloy
Contact plating	Au	Au
Insulating material	PA	PA
Material of housing	PA	PA

## Angled cable connectors

## Male cable connector, solder



## Contact arrangements



3pin

4pin

Contacts	Cable outlet	Designation	Order No.
3	3.5-5 mm	M8-MST03-S-D5	162 003 513 3001
4	3.5-5 mm	M8-MST04-S-D5	162 004 513 3001

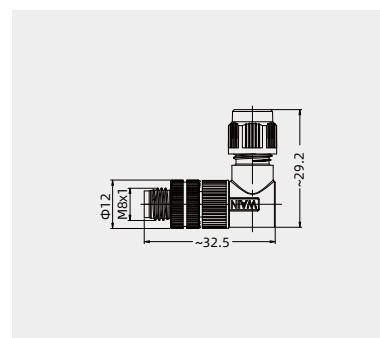

## Male cable connector, screw



## Contact arrangements



3pin

4pin

Contacts	Cable outlet	Designation	Order No.
3	3.5-5 mm	M8-M03-S-D5	162 003 511 3001
4	3.5-5 mm	M8-M04-S-D5	162 004 511 3001

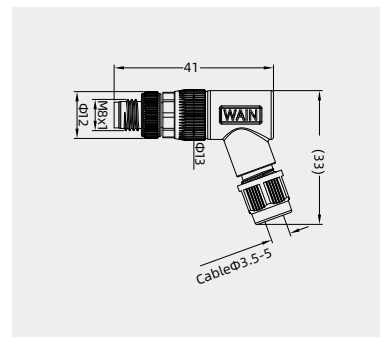

M8

## M8 Circular Connector

30/60V 4A

## Technical characteristics

	3-pole	4-pole
Rated current(40°C )	4A	4A
Rated voltage	60V	30V
Rated impulse voltage	800V	800V
Pollution degree	3	3
Overvoltage categorie	II	II
Contact resistance	≤ 10 mΩ	≤ 10 mΩ
Connector locking system	screw	screw
Termination	screw	screw,
Wire gauge	screw 0.14-0.5mm <sup>2</sup> (AWG26-20)	screw 0.14-0.5mm <sup>2</sup> (AWG26-20)
Cable outlet	3.5-5.5 mm	3.5-5.5 mm
Degree of protection	IP67	IP67
Mechanical operation	> 100	> 100
Limiting temperature	-40°C ...+85°C	-40°C ...+85°C
Material group	III	III
Material of contact	copper alloy	copper alloy
Contact plating	Au	Au
Insulating material	PA	PA
Material of housing	CuZn	CuZn

## Angled cable connectors, shielded

Male cable connector, screw, shielded

Recommend to use

Contacts	Cable outlet	Designation	Order No.
3	3.5-5 mm	M8-M03-S-D5.5-SH	162 003 501 2003
4	3.5-5 mm	M8-M04-S-D5.5-SH	162 004 501 2003



Contact arrangements



3pin

4pin

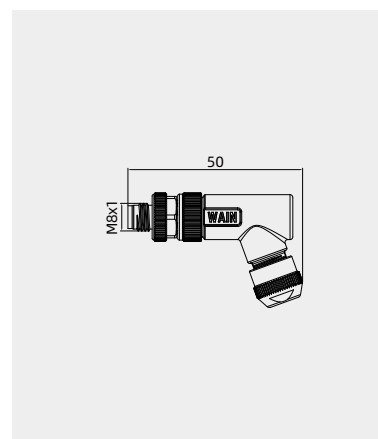

## M8 Circular Connector

30/60V 4A

## Technical characteristics

	3-pole	4-pole
Rated current(40°C )	4A	4A
Rated voltage	60V	30V
Rated impulse voltage	800V	800V
Pollution degree	3	3
Overvoltage categorie	II	II
Contact resistance	≤ 10 mΩ	≤ 10 mΩ
Connector locking system	screw	screw
Termination	screw, solder	screw, solder
Wire gauge	screw 0.14-0.5mm <sup>2</sup> (AWG26-20) ,solder 0.25mm <sup>2</sup> (AWG24)	screw 0.14-0.5mm <sup>2</sup> (AWG26-20) ,solder 0.25mm <sup>2</sup> (AWG24)
Cable outlet	3.5-5 mm	3.5-5 mm
Degree of protection	IP67	IP67
Mechanical operation	> 100	> 100
Limiting temperature	-40°C ...+85°C	-40°C ...+85°C
Material group	III	III
Material of contact	copper alloy	copper alloy
Contact plating	Au	Au
Insulating material	PA	PA
Material of housing	PA	PA

## Straight cable connectors

## Female cable connector, solder

Contacts	Cable outlet	Designation	Order No.
3	3.5-5 mm	M8-FST03-T-D5	162 003 423 3001
4	3.5-5 mm	M8-FST04-T-D5	162 004 423 3001



## Contact arrangements

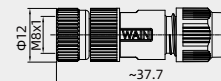

## Female cable connector, solder

## Recommend to use

Contacts	Cable outlet	Designation	Order No.
3	3.5-5 mm	M8-F03-T-D5	162 003 421 3001
4	3.5-5 mm	M8-F04-T-D5	162 004 421 3001



## Contact arrangements

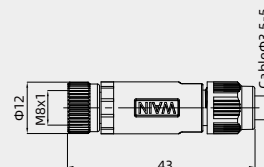

M8

## M8 Circular Connector

30/60V 4A

## Technical characteristics

	3-pole	4-pole
Rated current(40°C )	4A	4A
Rated voltage	60V	30V
Rated impulse voltage	800V	800V
Pollution degree	3	3
Overvoltage categorie	II	II
Contact resistance	≤ 10 mΩ	≤ 10 mΩ
Connector locking system	screw	screw
Termination	screw, solder	screw, solder
Wire gauge	screw0.14-0.5mm <sup>2</sup> (AWG26-20),solder 0.25mm <sup>2</sup> (AWG24)	screw0.14-0.5mm <sup>2</sup> (AWG26-20),solder 0.25mm <sup>2</sup> (AWG24)
Cable outlet	3.5-5 mm,3.5-5.5 mm	3.5-5 mm,3.5-5.5 mm
Degree of protection	IP67	IP67
Mechanical operation	> 100	> 100
Limiting temperature	-40°C ...+85°C	-40°C ...+85°C
Material group	III	III
Material of contact	copper alloy	copper alloy
Contact plating	Au	Au
Insulating material	PA	PA
Material of housing	CuZn	CuZn

## Straight cable connectors

Female cable connector, solder, shielded

Recommend to use

Contacts	Cable outlet	Designation	Order No.
3	3.5-5 mm	M8-FST03-T-D5-SH	162 003 423 2001
4	3.5-5 mm	M8-FST04-T-D5-SH	162 004 423 2001

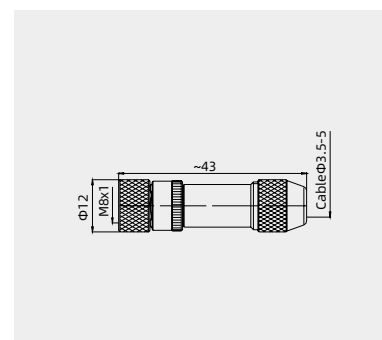

Contact arrangements



Female cable connector, solder, shielded

Contacts	Cable outlet	Designation	Order No.
3	3.5-5 mm	M8-F03-T-D5.5-SH	162 003 421 2001
4	3.5-5 mm	M8-F04-T-D5.5-SH	162 004 421 2001

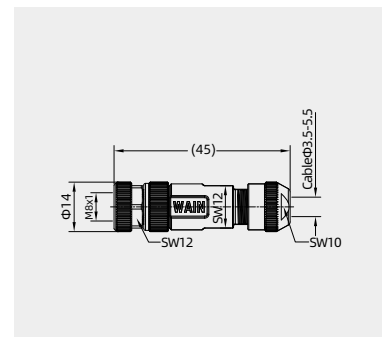

Contact arrangements



## M8 Circular Connector

30/60V 4A

## Technical characteristics

	3-pole	4-pole
Rated current(40°C )	4A	4A
Rated voltage	60V	30V
Rated impulse voltage	800V	800V
Pollution degree	3	3
Overvoltage categorie	II	II
Contact resistance	≤ 10 mΩ	≤ 10 mΩ
Connector locking system	screw	screw
Termination	screw, solder	screw, solder
Wire gauge	screw 0.14-0.5mm <sup>2</sup> (AWG26-20) ,solder 0.25mm <sup>2</sup> (AWG24)	screw 0.14-0.5mm <sup>2</sup> (AWG26-20) ,solder 0.25mm <sup>2</sup> (AWG24)
Cable outlet	3.5-5 mm	3.5-5 mm
Degree of protection	IP67	IP67
Mechanical operation	> 100	> 100
Limiting temperature	-40°C ...+85°C	-40°C ...+85°C
Material group	III	III
Material of contact	copper alloy	copper alloy
Contact plating	Au	Au
Insulating material	PA	PA
Material of housing	PA	PA

## Angled cable connectors

## Female cable connector, solder



Contact arrangements



3pin

4pin

Contacts	Cable outlet	Designation	Order No.
3	3.5-5 mm	M8-FST03-S-D5	162 003 523 3001
4	3.5-5 mm	M8-FST04-S-D5	162 004 523 3001

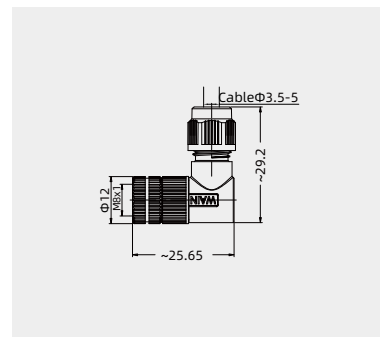

## Female cable connector, solder



Contact arrangements



3pin

4pin

Contacts	Cable outlet	Designation	Order No.
3	3.5-5 mm	M8-F03-S-D5	162 003 521 3001
4	3.5-5 mm	M8-F04-S-D5	162 004 521 3001

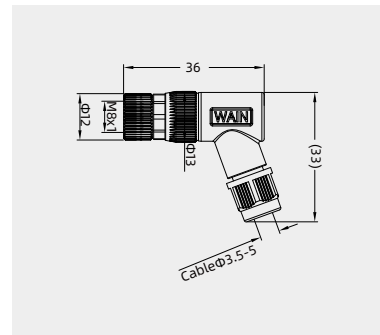

## M8 Circular Connector

30/60V 4A

## Technical characteristics

	3-pole	4-pole
Rated current(40°C )	4A	4A
Rated voltage	60V	30V
Rated impulse voltage	800V	800V
Pollution degree	3	3
Overvoltage categorie	II	II
Contact resistance	≤ 10 mΩ	≤ 10 mΩ
Connector locking system	screw	screw
Termination	screw	screw,
Wire gauge	screw 0.14-0.5mm <sup>2</sup> (AWG26-20)	screw 0.14-0.5mm <sup>2</sup> (AWG26-20)
Cable outlet	3.5-5.5 mm	3.5-5.5 mm
Degree of protection	IP67	IP67
Mechanical operation	> 100	> 100
Limiting temperature	-40°C ...+85°C	-40°C ...+85°C
Material group	III	III
Material of contact	copper alloy	copper alloy
Contact plating	Au	Au
Insulating material	PA	PA
Material of housing	CuZn	CuZn

## Straight cable connectors, shielded

Female cable connector, solder, shielded

Recommend to use

Contacts	Cable outlet	Designation	Order No.
3	3.5-5 mm	M8-F03-S-D5.5-SH	162 003 502 2007
4	3.5-5 mm	M8-F04-S-D5.5-SH	162 004 502 2003



## Contact arrangements

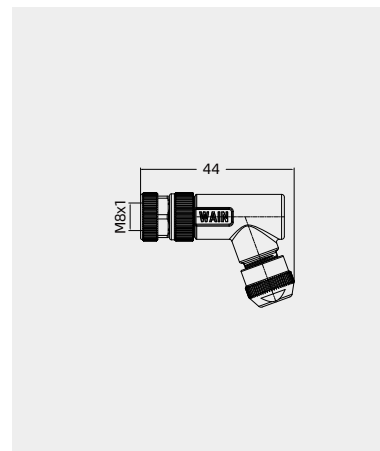



## Assembly instruction

### • Assembly instruction

- Strip length cable connectors

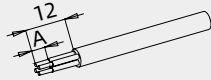

	Screw termination	solder version
Strip length A/mm	4mm	3mm

- Straight cable connectors, **shielded, solder**

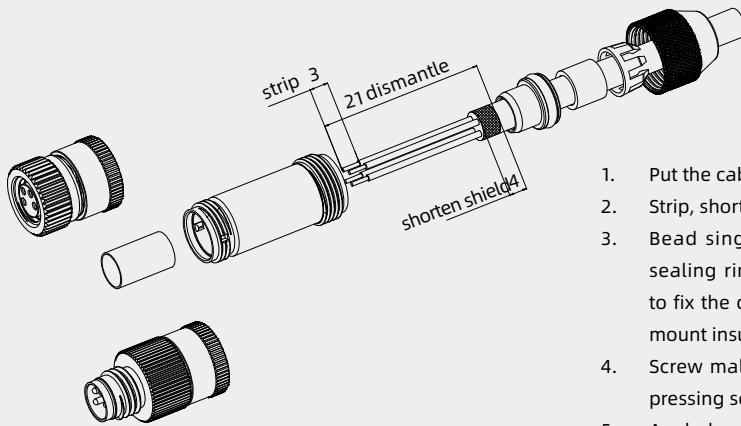

1. Put the cable through all the parts of the connector.
2. Strip, shorten, widen shield and lay around shielding ring.
3. Bead single wires through housing, mount shielding ring, sealing ring and pinch ring. Slightly tighten pressing screw to fix the cable. Bead insulating tube, solder single wires and mount insulating tube.
4. Screw male or female contact carrier to housing and tighten pressing screw.
5. Angled version: tighten locking screw.

M8

### Straight cable connectors, **shielded, screw clamp connection**

- Diameter of shield > 3.5 mm

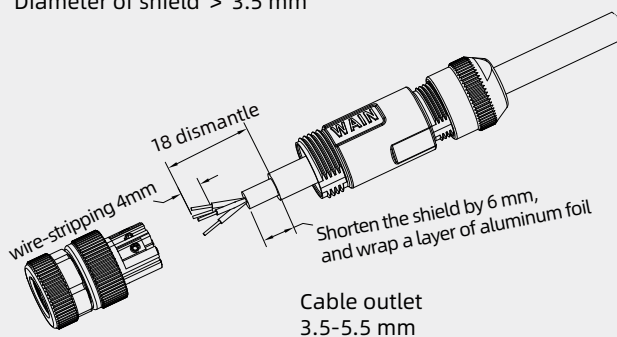

1. Put the cable through the housing.
2. Strip cable, shorten shielding braid.
3. Connect single wires.
4. Screw housing to either male or female contact carrier and tighten pressing screw.

- Diameter of shield ≤ 3.5 mm

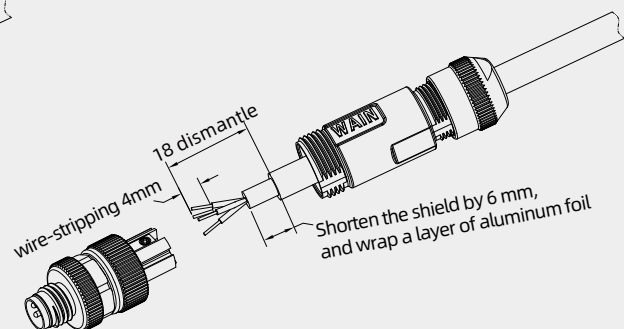

1. Put the cable through the housing.
2. Strip cable, shorten shielding braid, place it over cable coating and wrap it with copper tape.
3. Connect single wires.
4. Screw housing to either male or female contact carrier and tighten pressing screw.

Component part drawing

• Component part drawing

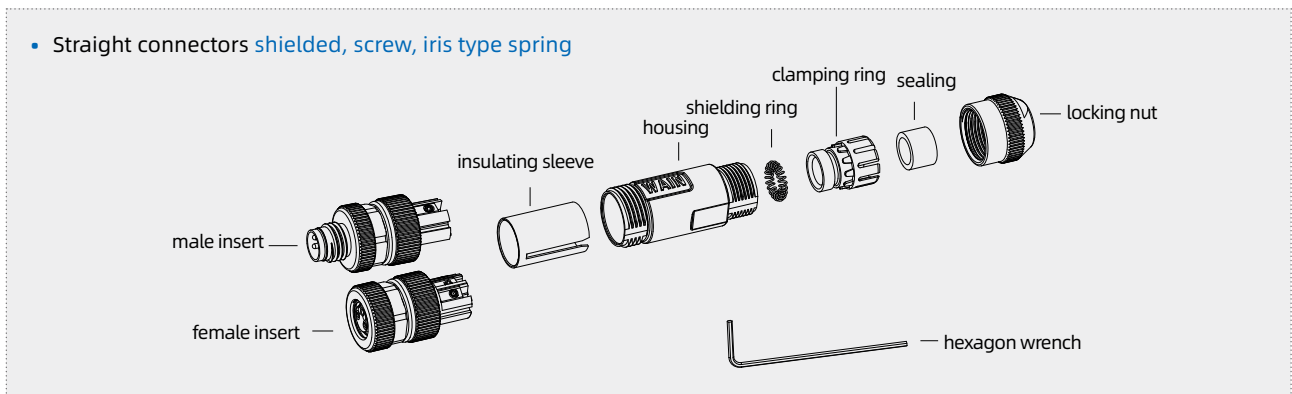
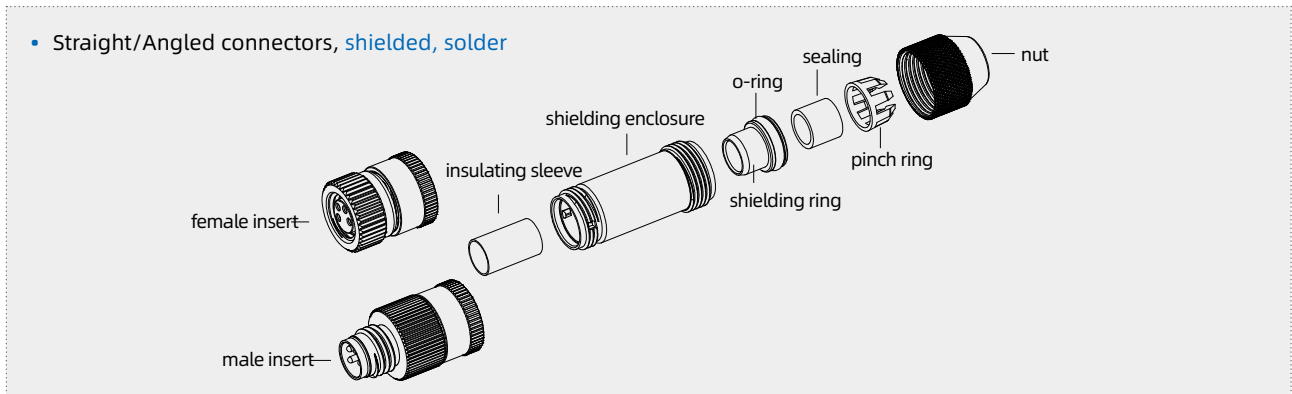
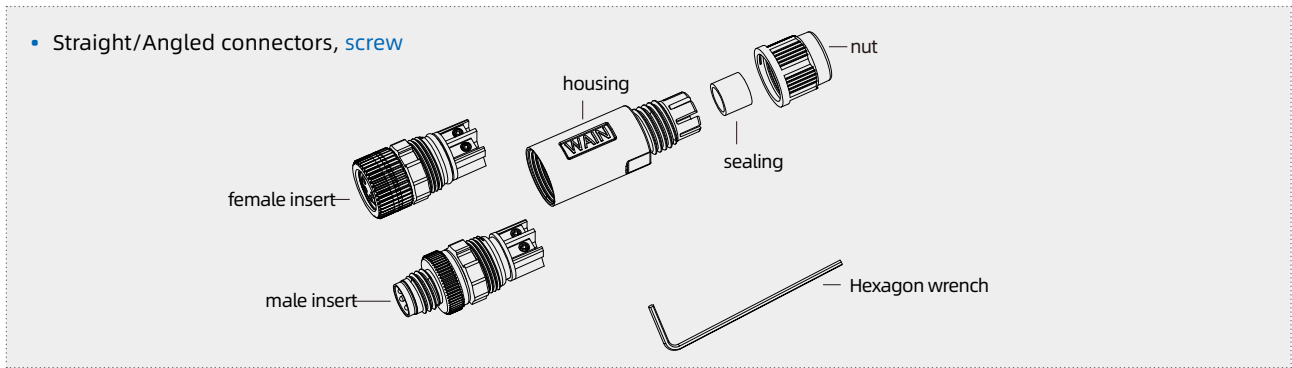
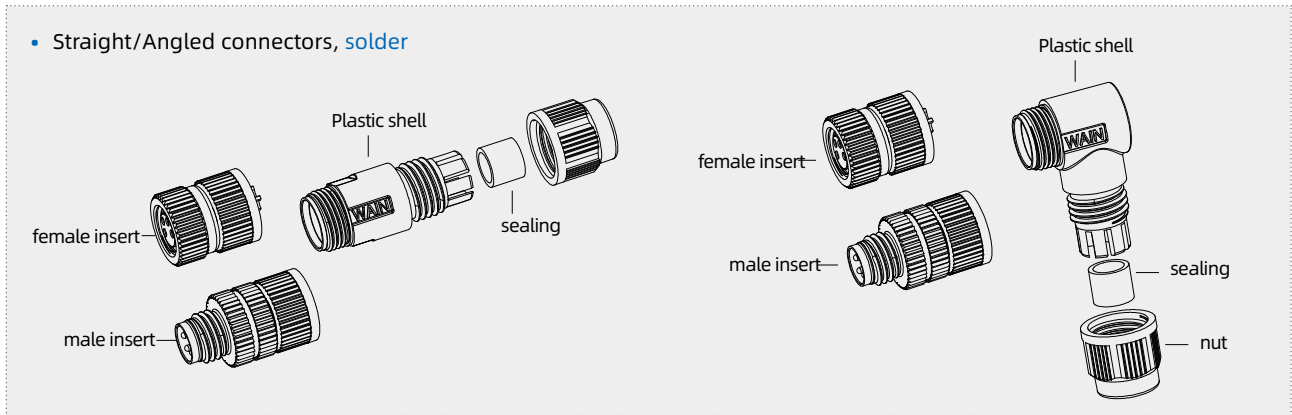

## Rating

## • Rating

## • Attenuation curve

- Attenuation curve according to DIN 47250-6
- For straight cable connectors (cable version IEEE 802.3) shielded

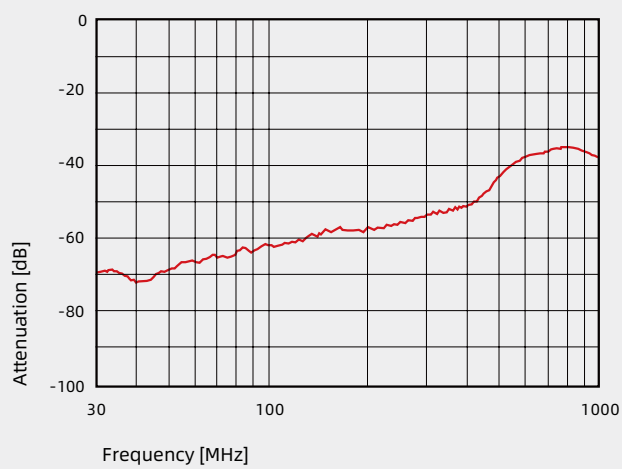

## M8 Circular Connector

30/60V 4A

## Technical characteristics

	3-pole	4-pole
Rated current(40°C )	4A	4A
Rated voltage	60V	30V
Rated impulse voltage	800V	800V
Pollution degree	3	3
Overvoltage categorie	II	II
Contact resistance	≤ 10 mΩ	≤ 10 mΩ
Connector locking system	screw	screw
Termination	crimp, moulded	crimp, moulded
Wire gauge	0.25mm <sup>2</sup> (AWG24)	0.25mm <sup>2</sup> (AWG24)
Cable outlet	-	-
Degree of protection	IP67	IP67
Mechanical operation	> 100	> 100
Limiting temperature	-25°C ...+85°C	-25°C ...+85°C
Material group	II	II
Material of contact	copper alloy	copper alloy
Contact plating	Au	Au
Insulating material	PA	PA
Material of housing	TPU	TPU

## Straight cable connectors,cable

Male cable connector moulded,  
screw

Recommend to use



Contacts	Cable length	Cable	Designation	Order No.
3	1.5m	3x0.25PVC	M8-M03-T-1.5-PVC	162 003 401 4001
		3x0.25PUR	M8-M03-T-1.5-PUR	162 003 401 4041
	5.0m	3x0.25PVC	M8-M03-T-5.0-PVC	162 003 401 4002
		3x0.25PUR	M8-M03-T-5.0-PUR	162 003 401 4042
4	1.5m	4x0.25PVC	M8-M04-T-1.5-PVC	162 004 401 4001
		4x0.25PUR	M8-M04-T-1.5-PUR	162 004 401 4041
	5.0m	4x0.25PVC	M8-M04-T-5.0-PVC	162 004 401 4002
		4x0.25PUR	M8-M04-T-5.0-PUR	162 004 401 4042

Contact arrangements

Male cable connector moulded,  
screw, shielded

Recommend to use



Contacts	Cablelength	Cable	Designation	Order No.
3	1.5m	3x0.25PVC	M8-M03-T-1.5-PVC-SH	162 003 401 2001
		3x0.25PUR	M8-M03-T-1.5-PUR-SH	162 003 401 2041
	5.0m	3x0.25PVC	M8-M03-T-5.0-PVC-SH	162 003 401 2002
		3x0.25PUR	M8-M03-T-5.0-PUR-SH	162 003 401 2042
4	1.5m	4x0.25PVC	M8-M04-T-1.5-PVC-SH	162 004 401 2001
		4x0.25PUR	M8-M04-T-1.5-PUR-SH	162 004 401 2041
	5.0m	4x0.25PVC	M8-M04-T-5.0-PVC-SH	162 004 401 2002
		4x0.25PUR	M8-M04-T-5.0-PUR-SH	162 004 401 2043

Contact arrangements

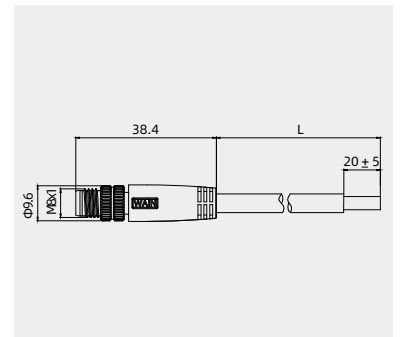
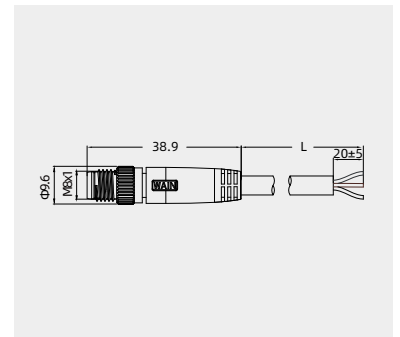

•Further cable length upon request, minimum order quantity 200 pieces.

## M8 Circular Connector

30/60V 4A

## Technical characteristics

	3-pole	4-pole
Rated current(40°C )	4A	4A
Rated voltage	60V	30V
Rated impulse voltage	800V	800V
Pollution degree	3	3
Overvoltage categorie	II	II
Contact resistance	≤ 10 mΩ	≤ 10 mΩ
Connector locking system	screw	screw
Termination	crimp, moulded	crimp, moulded
Wire gauge	0.25mm <sup>2</sup> (AWG24)	0.25mm <sup>2</sup> (AWG24)
Cable outlet	-	-
Degree of protection	IP67	IP67
Mechanical operation	> 100	> 100
Limiting temperature	-25°C ...+85°C	-25°C ...+85°C
Material group	II	II
Material of contact	copper alloy	copper alloy
Contact plating	Au	Au
Insulating material	PA	PA
Material of housing	TPU	TPU

## Angled cable connectors,cable

Male cable connector moulded,  
screw

Recommend to use



Contact arrangements



3pin 4pin

Contacts	Cable length	Cable	Designation	Order No.
3	1.5m	3x0.25PVC	M8-M03-S-1.5-PVC	162 003 501 4001
		3x0.25PUR	M8-M03-S-1.5-PUR	162 003 501 4041
	5.0m	3x0.25PVC	M8-M03-S-5.0-PVC	162 003 501 4002
		3x0.25PUR	M8-M03-S-5.0-PUR	162 003 501 4042
4	1.5m	4x0.25PVC	M8-M04-S-1.5-PVC	162 004 501 4001
		4x0.25PUR	M8-M04-S-1.5-PUR	162 004 501 4041
	5.0m	4x0.25PVC	M8-M04-S-5.0-PVC	162 004 501 4002
		4x0.25PUR	M8-M04-S-5.0-PUR	162 004 501 4042

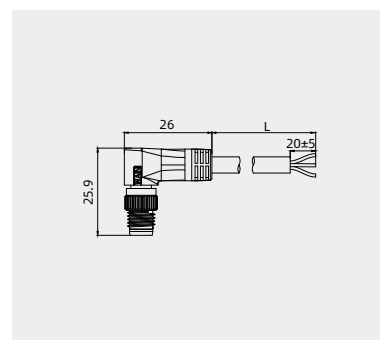
Male cable connector moulded,  
screw, shielded

Recommend to use



Contact arrangements



3pin 4pin

Contacts	Cable length	Cable	Designation	Order No.
3	1.5m	3x0.25PVC	M8-M03-S-1.5-PVC-SH	162 003 501 2001
		3x0.25PUR	M8-M03-S-1.5-PUR-SH	162 003 501 2041
	5.0m	3x0.25PVC	M8-M03-S-5.0-PVC-SH	162 003 501 2002
		3x0.25PUR	M8-M03-S-5.0-PUR-SH	162 003 501 2042
4	1.5m	4x0.25PVC	M8-M04-S-1.5-PVC-SH	162 004 501 2001
		4x0.25PUR	M8-M04-S-1.5-PUR-SH	162 004 501 2041
	5.0m	4x0.25PVC	M8-M04-S-5.0-PVC-SH	162 004 501 2002
		4x0.25PUR	M8-M04-S-5.0-PUR-SH	162 004 501 2042

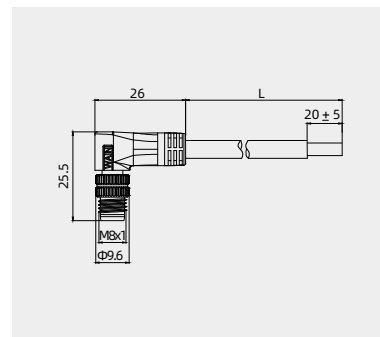

•Further cable length upon request, minimum order quantity 200 pieces.

## M8 Circular Connector

30/60V 4A

## Technical characteristics

	3-pole	4-pole
Rated current(40°C )	4A	4A
Rated voltage	60V	30V
Rated impulse voltage	800V	800V
Pollution degree	3	3
Overvoltage categorie	II	II
Contact resistance	≤ 10 mΩ	≤ 10 mΩ
Connector locking system	screw	screw
Termination	crimp, moulded	crimp, moulded
Wire gauge	0.25mm <sup>2</sup> (AWG24)	0.25mm <sup>2</sup> (AWG24)
Cable outlet	-	-
Degree of protection	IP67	IP67
Mechanical operation	> 100	> 100
Limiting temperature	-25°C ...+85°C	-25°C ...+85°C
Material group	II	II
Material of contact	copper alloy	copper alloy
Contact plating	Au	Au
Insulating material	PA	PA
Material of housing	TPU	TPU

## Straight cable connectors,cable

Female cable connector moulded,  
screw

Recommend to use



Contact arrangements

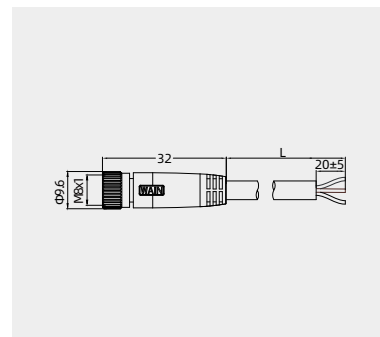

Contacts	Cable length	Cable	Designation	Order No.
3	1.5m	3x0.25PVC	M8-F03-T-1.5-PVC	162 003 402 4001
		3x0.25PUR	M8-F03-T-1.5-PUR	162 003 402 4041
	5.0m	3x0.25PVC	M8-F03-T-5.0-PVC	162 003 402 4002
		3x0.25PUR	M8-F03-T-5.0-PUR	162 003 402 4042
4	1.5m	4x0.25PVC	M8-F04-T-1.5-PVC	162 004 402 4001
		4x0.25PUR	M8-F04-T-1.5-PUR	162 004 402 4041
	5.0m	4x0.25PVC	M8-F04-T-5.0-PVC	162 004 402 4002
		4x0.25PUR	M8-F04-T-5.0-PUR	162 004 402 4042

Female cable connector moulded,  
screw, shielded

Contact arrangements

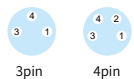

Contacts	Cable length	Cable	Designation	Order No.
3	1.5m	3x0.25PVC	M8-F03-T-1.5-PVC-SH	162 003 402 2001
		3x0.25PUR	M8-F03-T-1.5-PUR-SH	162 003 402 4061
	5.0m	3x0.25PVC	M8-F03-T-5.0-PVC-SH	162 003 402 4022
		3x0.25PUR	M8-F03-T-5.0-PUR-SH	162 003 402 4062
4	1.5m	4x0.25PVC	M8-F04-T-1.5-PVC-SH	162 004 402 2001
		4x0.25PUR	M8-F04-T-1.5-PUR-SH	162 004 402 2041
	5.0m	4x0.25PVC	M8-F04-T-5.0-PVC-SH	162 004 402 2002
		4x0.25PUR	M8-F04-T-5.0-PUR-SH	162 004 402 2042

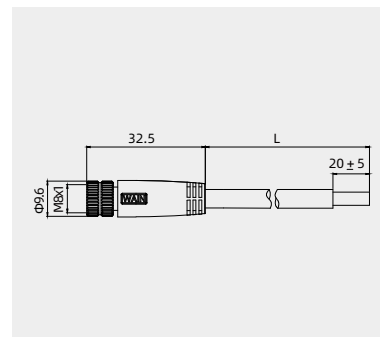

•Further cable length upon request, minimum order quantity 200 pieces.

## M8 Circular Connector

30/60V 4A

### Technical characteristics

	3-pole	4-pole
Rated current(40°C )	4A	4A
Rated voltage	60V	30V
Rated impulse voltage	800V	800V
Pollution degree	3	3
Overvoltage categorie	II	II
Contact resistance	≤ 10 mΩ	≤ 10 mΩ
Connector locking system	screw	screw
Termination	crimp, moulded	crimp, moulded
Wire gauge	0.25mm <sup>2</sup> (AWG24)	0.25mm <sup>2</sup> (AWG24)
Cable outlet	-	-
Degree of protection	IP67	IP67
Mechanical operation	> 100	> 100
Limiting temperature	-25°C ...+85°C	-25°C ...+85°C
Material group	II	II
Material of contact	copper alloy	copper alloy
Contact plating	Au	Au
Insulating material	PA	PA
Material of housing	TPU	TPU

### Angled cable connectors,cable

Female cable connector moulded,  
screw,shielded

Recommend to use



Contact arrangements



Contacts	Cable length	Cable	Designation	Order No.
3	1.5m	3x0.25PVC	M8-F03-S-1.5-PVC-SH	162 003 502 2001
		3x0.25PUR	M8-F03-S-1.5-PUR-SH	162 003 502 4061
	5.0m	3x0.25PVC	M8-F03-S-5.0-PVC-SH	162 003 502 2002
		3x0.25PUR	M8-F03-S-5.0-PUR-SH	162 003 502 4062
4	1.5m	4x0.25PVC	M8-F04-S-1.5-PVC-SH	162 004 502 2001
		4x0.25PUR	M8-F04-S-1.5-PUR-SH	162 004 502 2041
	5.0m	4x0.25PVC	M8-F04-S-5.0-PVC-SH	162 004 502 2002
		4x0.25PUR	M8-F04-S-5.0-PUR-SH	162 004 502 2042

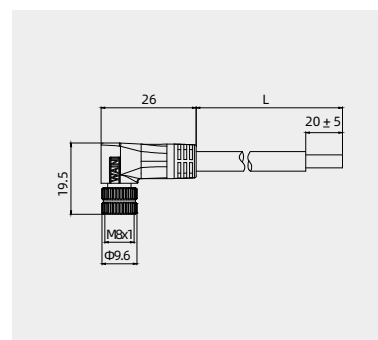

Male cable connector moulded,  
screw, shielded

Recommend to use



Contact arrangements



Contacts	Cable length	Cable	Designation	Order No.
3	1.5m	3x0.25PVC	M8-F03-S-1.5-PVC-LED	162 003 502 4003
		3x0.25PUR	M8-F03-S-1.5-PUR-LED	162 003 502 4043
	5.0m	3x0.25PVC	M8-F03-S-5.0-PVC-LED	162 003 502 4004
		3x0.25PUR	M8-F03-S-5.0-PUR-LED	162 003 502 4044

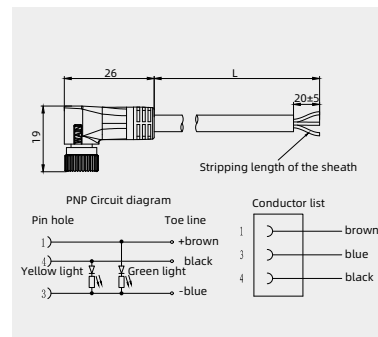

•Further cable length upon request, minimum order quantity 200 pieces.

## M8 Circular Connector

30/60V 4A

## Technical characteristics

	3-pole	4-pole
Rated current(40°C )	4A	4A
Rated voltage	60V	30V
Rated impulse voltage	800V	800V
Pollution degree	3	3
Overvoltage categorie	II	II
Contact resistance	≤ 10 mΩ	≤ 10 mΩ
Connector locking system	screw	screw
Termination	crimp, moulded	crimp, moulded
Wire gauge	0.25mm <sup>2</sup> (AWG24)	0.25mm <sup>2</sup> (AWG24)
Cable outlet	-	-
Degree of protection	IP67	IP67
Mechanical operation	> 100	> 100
Limiting temperature	-25°C ...+85°C	-25°C ...+85°C
Material group	II	II
Material of contact	copper alloy	copper alloy
Contact plating	Au	Au
Insulating material	PA	PA
Material of housing	TPU	TPU

## Cable connectors-wire jumper

## Male/female cable connector



## Contact arrangements



Contacts	Cable length	Cable	Designation	Order No.
3	1.5m	3x0.25PVC	M8-M03-T/F03-T-1.5-PVC	162 003 401 4010
		3x0.25PUR	M8-M03-T/F03-T-1.5-PUR	162 003 401 4011
	5.0m	3x0.25PVC	M8-M03-T/F03-T-5.0-PVC	162 003 401 4506
		3x0.25PUR	M8-M03-T/F03-T-5.0-PUR	162 003 401 4004
4	1.5m	4x0.25PVC	M8-M04-T/F04-T-1.5-PVC	162 004 401 4010
		4x0.25PUR	M8-M04-T/F04-T-1.5-PUR	162 004 401 4011
	5.0m	4x0.25PVC	M8-M04-T/F04-T-5.0-PVC	162 004 401 4007
		4x0.25PUR	M8-M04-T/F04-T-5.0-PUR	162 004 401 4008

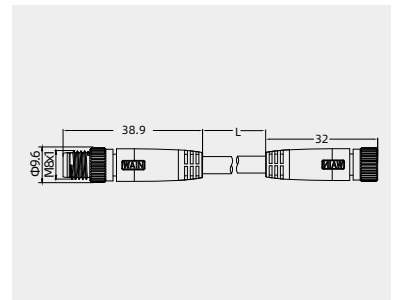

## Male cable connector



## Contact arrangements



Contacts	Cable length	Cable	Designation	Order No.
3	1.5m	3x0.25PVC	M8-M03-T/M03-T-1.5-PVC	162 003 401 4012
		3x0.25PVC	M8-M03-T/M03-T-5.0-PVC	162 003 401 4013
4	5.0m	4x0.25PVC	M8-M04-T/M04-T-1.5-PVC	162 004 401 4012
		4x0.25PVC	M8-M04-T/M04-T-5.0-PVC	162 004 401 4009

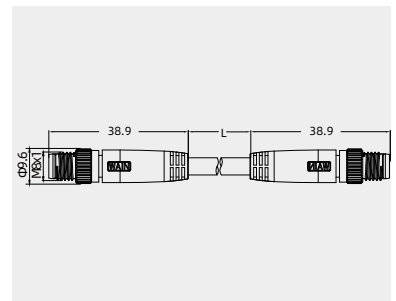

## Female cable connector



## Contact arrangements

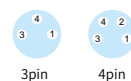

Contacts	Cable length	Cable	Designation	Order No.
3	1.5m	3x0.25PVC	M8-F03-T/F03-T-1.5-PVC	162 003 402 4006
		3x0.25PVC	M8-F03-T/F03-T-5.0-PVC	162 003 402 4005
4	5.0m	4x0.25PVC	M8-F04-T/F04-T-1.5-PVC	162 004 402 4014
		4x0.25PVC	M8-F04-T/F04-T-5.0-PVC	162 004 402 4013

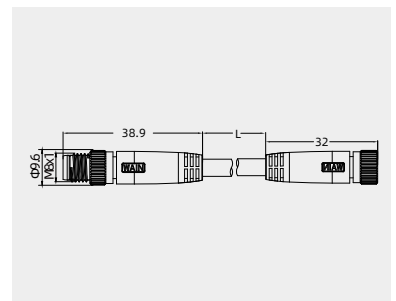

•Other cable lengths can be customized, PVC/PUR double-ended connectors, male/female, straight/angled, shielded/unshielded, freely combinable.



## M8 Circular Connector

30V 4A

## Technical characteristics

	4-pole
Rated current(40°C )	4A
Rated voltage	30V
Rated impulse voltage	800V
Pollution degree	3
Overvoltage categorie	II
Contact resistance	≤ 10 mΩ
Connector locking system	screw
Termination	crimp, moulded
Wire gauge	0.25mm <sup>2</sup> (AWG24)
Cable outlet	-
Degree of protection	IP67
Mechanical operation	> 100
Limiting temperature	-25°C ...+85°C
Material group	II
Material of contact	copper alloy
Contact plating	Au
Insulating material	PA
Material of housing	TPU

## Cable connectors-wire jumper

## Male/female cable connector



## Contact arrangements



Contacts	Cable length	Cable	Designation	Order No.
4	1.5m	4x0.25PUR	M8-M04-T/F04-T-1.5-PUR-EtherCat	162 004 401 4077
	5.0m	4x0.25PUR	M8-M04-T/F04-T-5.0-PUR-EtherCat	162 004 401 4045

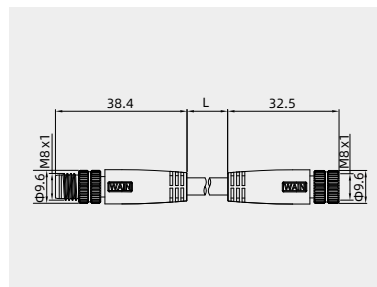

## Male cable connector



## Contact arrangements



Contacts	Cable length	Cable	Designation	Order No.
4	1.5m	4x0.25PUR	M8-M04-T/M04-T-1.5-PUR-EtherCat	162 004 401 4080
	5.0m	4x0.25PUR	M8-M04-T/M04-T-5.0-PUR-EtherCat	162 004 401 4014

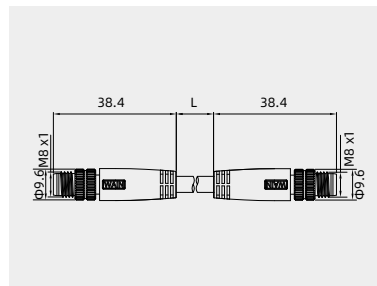

## Female cable connector



## Contact arrangements



Contacts	Cable length	Cable	Designation	Order No.
4	1.5m	4x0.25PUR	M8-F04-T/F04-T-1.5-PUR-EtherCat	162 004 402 4021
	5.0m	4x0.25PUR	M8-F04-T/F04-T-5.0-PUR-EtherCat	162 004 402 4022

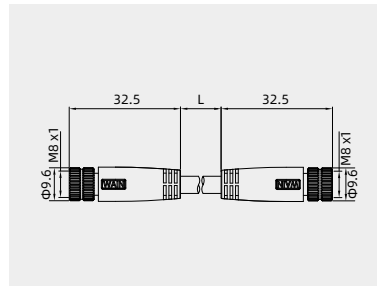

•Other cable lengths can be customized, PVC/PUR double-ended connectors, male/female, straight/angled, shielded/unshielded, freely combinable.

## M8 Circular Connector

30V 4A

### Technical characteristics

	4-pole
Rated current(40°C )	4A
Rated voltage	30V
Rated impulse voltage	800V
Pollution degree	3
Overvoltage categorie	II
Contact resistance	≤ 10 mΩ
Connector locking system	screw
Termination	crimp, moulded
Wire gauge	0.25mm <sup>2</sup> (AWG24)
Cable outlet	-
Degree of protection	IP67
Mechanical operation	> 100
Limiting temperature	-25°C ...+85°C
Material group	II
Material of contact	copper alloy
Contact plating	Au
Insulating material	PA
Material of housing	TPU

### Cable connectors-wire jumper

#### Male cable connector



Contacts	Cable length	Cable	Designation	Order No.
4	1.5m	4x0.25PUR	M8-M04-T/RJ45-T-1.5-PUR-EtherCat	162 004 401 4087
	5.0m	4x0.25PUR	M8-M04-T/RJ45-T-5.0-PUR-EtherCat	162 004 401 4097

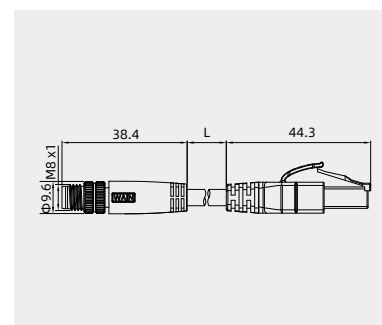

#### Contact arrangements



4pin

•Other cable lengths can be customized, PVC/PUR double-ended connectors, male/female, straight/angled, shielded/unshielded, freely combinable.

## Technical characteristics

### Specifications of standard cable

	3-pole	4-pole
Wire gauge mm <sup>2</sup>	3x0.14mm <sup>2</sup> / 3x0.25mm <sup>2</sup>	4x0.25mm <sup>2</sup>
Material jacket	PVC/PUR / PVC/PUR	PUR / PVC
Insulation wire	PVC	PVC
Design of wire (mm)	18x0.1 / 32x0.1	32x0.1
Cable jacket (mm)	3 / 4.5	4.5
Resistance of wire	148Ω/Km / 79.5Ω/Km / 72Ω/Km	79.9Ω/Km
Temperature range (cable in move)	-5°C ...+70°C	-5°C ...+70°C
Temperature range (cable not in move)	-15°C ...+70°C	-15°C ...+70°C
Bending radius (cable in move)	min. 10xD	min. 10xD
Bending radius (cable not in move)	min. 5xD	min. 5xD
Approval	-	-

### Attenuation curve

- Attenuation curve according to DIN 47250-6
- For straight cable connectors

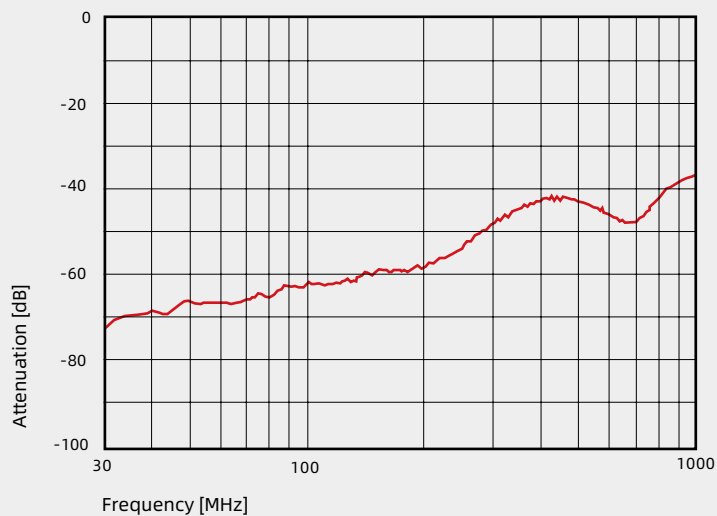

# M8 Circular Connector

30/60V 4A

## Technical characteristics

	3-pole	4-pole
Rated current(40°C )	4A	4A
Rated voltage	60V	30V
Rated impulse voltage	800V	800V
Pollution degree	3	3
Overvoltage categorie	II	II
Contact resistance	≤ 10 mΩ	≤ 10 mΩ
Connector locking system	screw	screw
Termination	dip solder, single-strand 0.25mm <sup>2</sup>	dip solder, single-strand 0.25mm <sup>2</sup>
Wire gauge	0.25mm <sup>2</sup> (AWG24)	0.25mm <sup>2</sup> (AWG24)
Cable outlet	-	-
Degree of protection	IP67	IP67
Mechanical operation	> 100	> 100
Limiting temperature	-40°C ...+85°C	-40°C ...+85°C
Material group	II	II
Material of contact	copper alloy	copper alloy
Contact plating	Au	Au
Insulating material	PA	PA
Material of housing	CuZn	CuZn

## Socket

Male panel mount connector  
with single wires 0.25mm<sup>2</sup>  
length 0.2m

Recommend to use



Contact arrangements



Contacts	Thread	Designation	Order No.
3	M8	M8-M03-BK-M8-W0.25	162 003 301 4001
4	M8	M8-M04-BK-M8-W0.25	162 004 301 4001

Customized cable length upon request

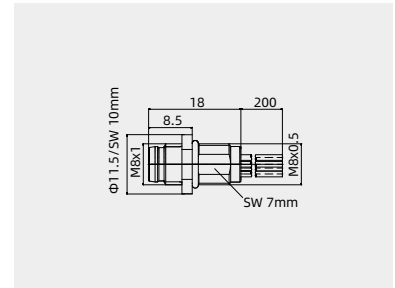

Male panel mount connector,  
front fastened, with single wires  
0.25mm<sup>2</sup>  
length 0.2m



Contact arrangements

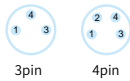

Contacts	Thread	Designation	Order No.
3	M8	M8-M03-BKR-M8-W0.25	162 003 301 4011
4	M8	M8-M04-BKR-M8-W0.25	162 004 301 4011

Customized cable length upon request

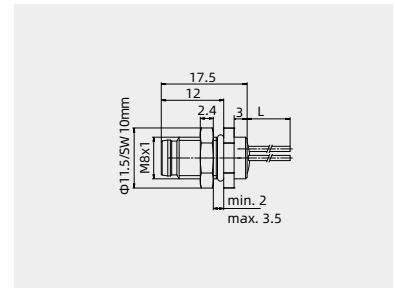

Male panel mount connector,  
front fastened, dip solder



Contact arrangements



Contacts	Thread	Designation	Order No.
3	M8	M8-M03-BKR-M8-D	162 003 314 1011
4	M8	M8-M04-BKR-M8-D	162 004 314 1011

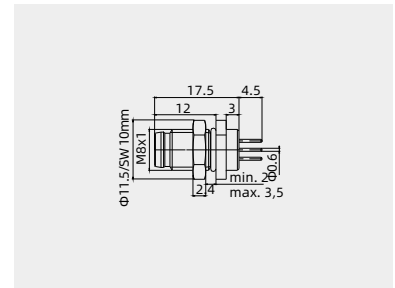

## M8 Circular Connector

30/60V 4A

## Technical characteristics

	3-pole	4-pole
Rated current(40°C )	4A	4A
Rated voltage	60V	30V
Rated impulse voltage	800V	800V
Pollution degree	3	3
Overvoltage categorie	II	II
Contact resistance	≤ 10 mΩ	≤ 10 mΩ
Connector locking system	screw	screw
Termination	solder	solder
Wire gauge	-	-
Cable outlet	-	-
Degree of protection	IP67	IP67
Mechanical operation	> 100	> 100
Limiting temperature	-40°C ...+85°C	-40°C ...+85°C
Material group	II	II
Material of contact	copper alloy	copper alloy
Contact plating	Au	Au
Insulating material	PA	PA
Material of housing	CuZn	CuZn

## Socket

Male panel mount connector,  
solder

Contacts	Thread	Designation	Order No.
3	M8	M8-M03-BK-M8-C	162 003 301 2500
4	M8	M8-M04-BK-M8-C	162 004 313 1001

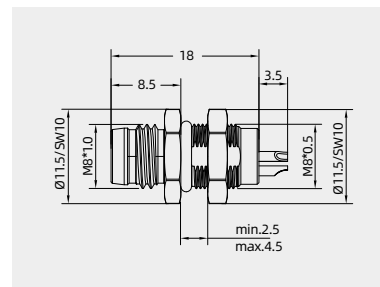

Contact arrangements



3pin



4pin

Male panel mount connector,  
front fastened, solder

Contacts	Thread	Designation	Order No.
3	M8	M8-M03-BKR-M8-C	162 003 301 1012
4	M8	M8-M04-BKR-M8-C	162 004 301 2501

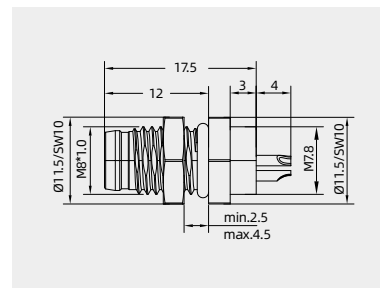

Contact arrangements



3pin



4pin

M8

## M8 Circular Connector

30/60V 4A

## Technical characteristics

	3-pole	4-pole
Rated current(40°C )	4A	4A
Rated voltage	60V	30V
Rated impulse voltage	800V	800V
Pollution degree	3	3
Overvoltage categorie	II	II
Contact resistance	≤ 10 mΩ	≤ 10 mΩ
Connector locking system	screw	screw
Termination	dip solder, single-strand 0.25mm <sup>2</sup>	dip solder, single-strand 0.25mm <sup>2</sup>
Wire gauge	-	-
Cable outlet	-	-
Degree of protection	IP67	IP67
Mechanical operation	> 100	> 100
Limiting temperature	-40°C ...+85°C	-40°C ...+85°C
Material group	II	II
Material of contact	copper alloy	copper alloy
Contact plating	Au	Au
Insulating material	PA	PA
Material of housing	CuZn	CuZn

## Socket

Female panel mount connector  
with single wires 0.25mm<sup>2</sup>  
length 0.2m



Contact arrangements

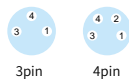

Contacts	Thread	Designation	Order No.
3	M8	M8-F03-BK-M8-W0.25	162 003 302 4001
4	M8	M8-F04-BK-M8-W0.25	162 004 302 4001

Customized cable length upon request

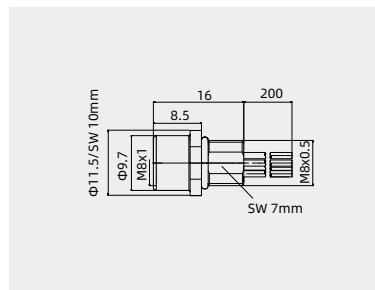

Female panel mount connector,  
front fastened,  
with single wires 0.25mm<sup>2</sup>  
length 0.2m



Contact arrangements

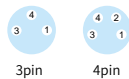

Contacts	Thread	Designation	Order No.
3	M8	M8-F03-BKR-M8-W0.25	162 003 302 4011
4	M8	M8-F04-BKR-M8-W0.25	162 004 302 4011

Customized cable length upon request

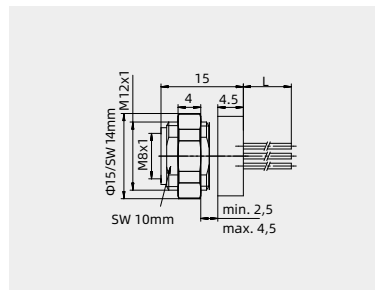

Female panel mount connector,  
front fastened, with single wires



Contact arrangements



Contacts	Contact length A	Thread	Designation	Order No.
3	9.5 mm	M8	M8-F03-BKR-M8-D9.5	162 003 324 1013
	4.7 mm	M8	M8-F03-BKR-M8-D4.7	162 003 324 1012
4	0.5 mm	M8	M8-F03-BKR-M8-D0.5	162 003 324 1011
	9.5 mm	M8	M8-F04-BKR-M8-D9.5	162 004 324 1013
4	4.7 mm	M8	M8-F04-BKR-M8-D4.7	162 004 324 1012
	0.5 mm	M8	M8-F04-BKR-M8-D0.5	162 004 324 1011

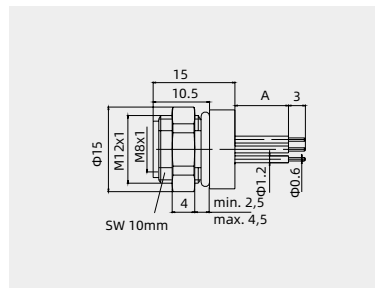

## M8 Circular Connector

30/60V 4A

## Technical characteristics

	3-pole	4-pole
Rated current(40°C )	4A	4A
Rated voltage	60V	30V
Rated impulse voltage	800V	800V
Pollution degree	3	3
Overvoltage categorie	II	II
Contact resistance	≤ 10 mΩ	≤ 10 mΩ
Connector locking system	solder	solder
Termination	dip solder	dip solder
Wire gauge	-	-
Cable outlet	-	-
Degree of protection	IP67	IP67
Mechanical operation	> 100	> 100
Limiting temperature	-40°C ...+85°C	-40°C ...+85°C
Material group	II	II
Material of contact	copper alloy	copper alloy
Contact plating	Au	Au
Insulating material	PA	PA
Material of housing	CuZn	CuZn

## Socket

Female panel mount connector,  
solder

Contact arrangements

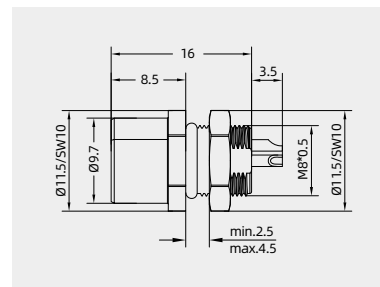

Contacts	Thread	Designation	Order No.
3	M8	M8-F03-BK-M8-C	162 003 302 2500
4	M8	M8-F04-BK-M8-C	162 004 302 2500

Female panel mount connector,  
front fastened,solder

Contact arrangements



Contacts	Thread	Designation	Order No.
3	M8	M8-F03-BKR-M12-C	162 003 302 2501
4	M8	M8-F04-BKR-M12-C	162 004 302 2501

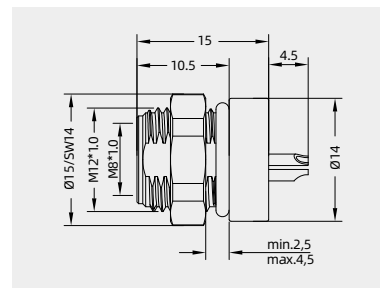

M8

# M8 Circular Connector

## • Contact arrangements

### • Male insert (mating side)

#### 3contacts

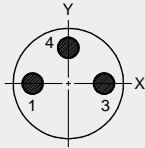

	X	Y	
1	-1.75	0.00	1 brown
2	-	-	2 -
3	1.75	0.00	3 blue
4	0.00	1.75	4 black

### • Female insert (mating side)

#### 3contacts

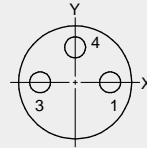

	X	Y	
1	1.75	0.00	1 brown
2	-	-	2 -
3	-1.75	0.00	3 blue
4	0.00	-1.75	4 black

#### 4contacts

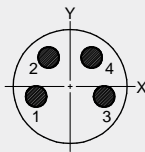

	X	Y	
1	-1.70	-0.50	1 brown
2	-1.08	1.45	2 white
3	1.70	-0.50	3 blue
4	1.08	1.45	4 black

#### 4contacts

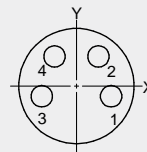

	X	Y	
1	1.70	-0.50	1 brown
2	1.08	1.45	2 white
3	-1.70	-0.50	3 blue
4	-1.08	1.45	4 black



Panel cut out

- Drilling schemes male insert (PCB), shielding sheet

- Drilling schemes male insert (PCB), shielding sheet

3contacts

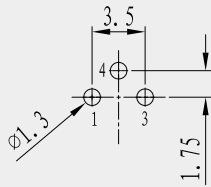

3contacts

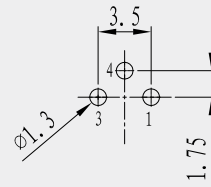

4contacts

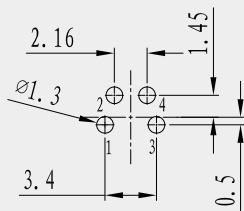

4contacts

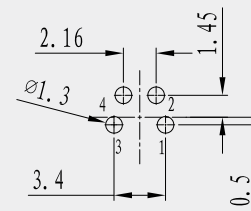

M8 Circular Connector

• Panel cut out

- With flats as anti-rotation device
- With bore hole
- With thread to screw in

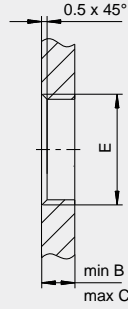
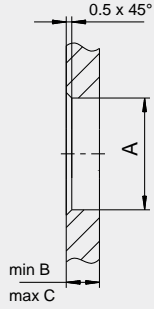
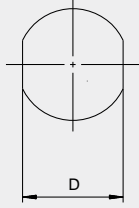

Thread E	A	B	C	D
M8x0.5	8.1	2.5	4.5	7.1

Tightening moment 1Nm

- With flats as anti-rotation device
- With bore hole
- With thread to screw in

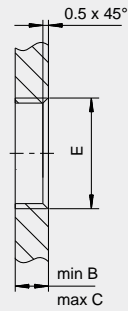
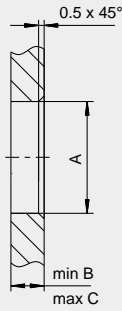
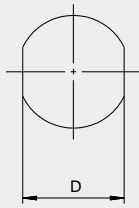

Thread E	A	B	C	D
M8x1	8.1	2.5	4.5	7.1

Tightening moment 1Nm

Accessories

Protection cover  
for male cable connector



Description	Designation	Order No.
Without cord	M8-MCV	162 000 001 9003
With cord	M8-MCV/1	162 000 001 9001

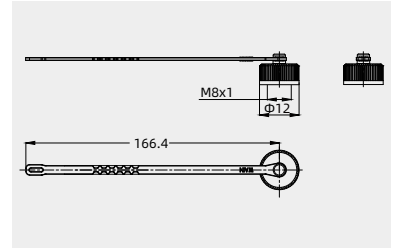

Protection cover  
for female cable connector



Description	Designation	Order No.
Without cord	M8-FCV	162 000 002 9003
With cord	M8-FCV/1	162 000 002 9001

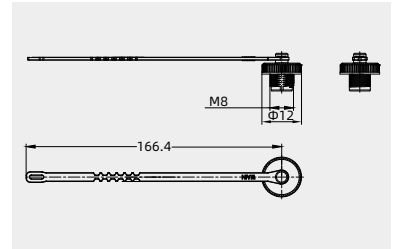

## M8-B Circular Connector

30V 4A

## Technical characteristics

	5-pole
Rated current(40°C )	4A
Rated voltage	30V
Rated impulse voltage	800V
Pollution degree	3
Overvoltage categorie	II
Contact resistance	≤ 10 mΩ
Connector locking system	screw / connect straight
Termination	crimp, moulded
Wire gauge	0.25mm <sup>2</sup> (AWG24)
Cable outlet	-
Degree of protection	IP67
Mechanical operation	> 100
Limiting temperature	-25°C ...+85°C
Material group	II
Material of contact	copper alloy
Contact plating	Au
Insulating material	PA
Material of housing	TPU

## Straight cable connectors,cable

Male cable connector moulded,  
screw

## Contact arrangements



5pin

Contacts	Cable length	Cable	Designation	Order No.
5	1.5m	5x0.25PVC	M8-M05B-T-1.5-PVC	162 005 401 4001
		5x0.25PUR	M8-M05B-T-1.5-PUR	162 005 401 4002
	5.0m	5x0.25PVC	M8-M05B-T-5.0-PVC	162 005 401 4003
		5x0.25PUR	M8-M05B-T-5.0-PUR	162 005 401 4004

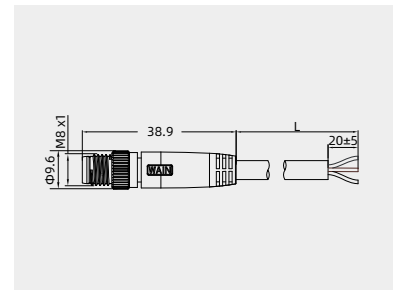
Male cable connector moulded  
connect straight

## Contact arrangements



5pin

Contacts	Cable length	Cable	Designation	Order No.
5	1.5m	5x0.25PVC	M8Q-M05B-T-1.5-PVC	162 005 401 4005
		5x0.25PUR	M8Q-M05B-T-1.5-PUR	162 005 401 4006
	5.0m	5x0.25PVC	M8Q-M05B-T-5.0-PVC	162 005 401 4007
		5x0.25PUR	M8Q-M05B-T-5.0-PUR	162 005 401 4008

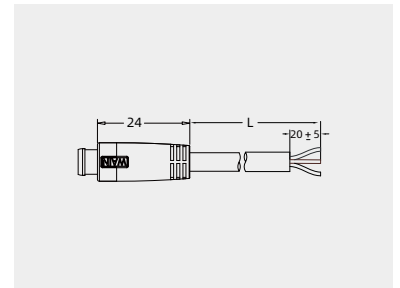

•Further cable length upon request, minimum order quantity 200 pieces.

## M8-B Circular Connector

30V 4A

## Technical characteristics

	5-pole
Rated current(40°C )	4A
Rated voltage	30V
Rated impulse voltage	800V
Pollution degree	3
Overvoltage categorie	II
Contact resistance	≤ 10 mΩ
Connector locking system	screw / connect straight
Termination	crimp, moulded
Wire gauge	0.25mm <sup>2</sup> (AWG24)
Cable outlet	-
Degree of protection	IP67
Mechanical operation	> 100
Limiting temperature	-25°C ...+85°C
Material group	II
Material of contact	copper alloy
Contact plating	Au
Insulating material	PA
Material of housing	TPU

## Straight cable connectors,cable

Female cable connector moulded,  
screw

## Contact arrangements



5pin

Contacts	Cable length	Cable	Designation	Order No.
5	1.5m	5x0.25PVC	M8-F05B-T-1.5-PVC	162 005 402 4001
		5x0.25PUR	M8-F05B-T-1.5-PUR	162 005 402 4002
	5.0m	5x0.25PVC	M8-F05B-T-5.0-PVC	162 005 402 4003
		5x0.25PUR	M8-F05B-T-5.0-PUR	162 005 402 4004

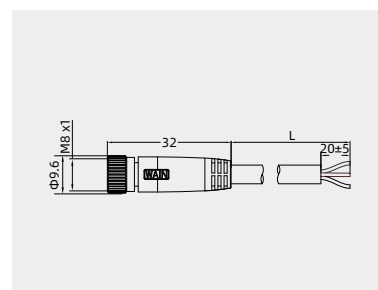
Female cable connector moulded,  
connect straight

## Contact arrangements



5pin

Contacts	Cable length	Cable	Designation	Order No.
5	1.5m	5x0.25PVC	M8Q-F05B-T-1.5-PVC	162 005 402 4005
		5x0.25PUR	M8Q-F05B-T-1.5-PUR	162 005 402 4006
	5.0m	5x0.25PVC	M8Q-F05B-T-5.0-PVC	162 005 402 4007
		5x0.25PUR	M8Q-F05B-T-5.0-PUR	162 005 402 4008

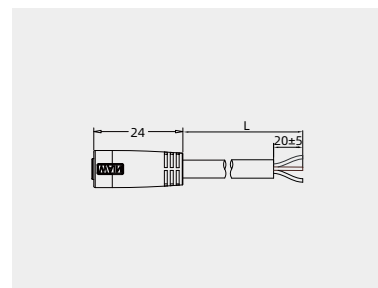

•Further cable length upon request, minimum order quantity 200 pieces.

## M12 Circular Connector,A-coded

Standards: IEC-61076-2-101



- Cable Connector
- Shielded / unshielded series
- Installable series and moulded cable series
- Thread locking M12X1
- Screw terminal and welding terminal
- Shielding ring and ring spring shielding connection
- Cable length 1.5m and 5m
- Other cable length upon request, minimum order quantity 200 pieces
- Cable material can be customized according to requirements
- Degree of protection IP67/ IP68
- Transparent case for PCB with LED

## M12-A Circular Connector

30/60/125/250V 1.5/2/4A

## Technical characteristics

	3-pole	4-pole	5-pole	8-pole	12-pole
Rated current (40°C)	4A	4A	4A	2A	1.5A
Rated voltage	250V	250V	125V	60V	30V
Rated impulse voltage	2500V	2500V	1500V	800V	800V
Pollution degree	3	3	3	3	3
Overvoltage categorie	II	II	II	II	II
Contact resistance	≤ 10 mΩ	≤ 10 mΩ	≤ 10 mΩ	≤ 10 mΩ	≤ 10 mΩ
Connector locking system	screw M12x1	screw M12x1	screw M12x1	screw M12x1	screw M12x1
Termination	screw/solder	screw/solder	screw/solder	screw/solder	solder
Wire gauge	max.0.75mm <sup>2</sup> (max.AWG18)	max.0.75mm <sup>2</sup> (max.AWG18)	max.0.75mm <sup>2</sup> (max.AWG18)	max.0.5mm <sup>2</sup> max.AWG20)	max.0.25mm <sup>2</sup> max.AWG24)
Cable outlet	4-6,6-8 mm	4-6,6-8 mm	4-6,6-8 mm	6-8 mm	6-8 mm
Degree of protection	IP67	IP67	IP67	IP67	IP67
Mechanical operation	> 100	> 100	> 100	> 100	> 100
Limiting temperature	-40°C ...+85°C	-40°C ...+85°C	-40°C ...+85°C	-40°C ...+85°C	-40°C ...+85°C
Material group	III	III	III	III	III
Material of contact	copper alloy	copper alloy	copper alloy	copper alloy	copper alloy
Contact plating	Au	Au	Au	Au	Au
Insulating material	PA	PA	PA	PA	PA
Material of housing	PA/PBT	PA/PBT	PA/PBT	PA/PBT	PA/PBT

## Straight cable connectors

## Male cable connector, plastic

locking system, screw clamp connection



A-Code



3pin

4pin

5pin

8pin



12pin

Contacts	Cable outlet	Designation	Order No.
3	4-6 mm	M12P-M03A-T-D6	163 003 411 3101
	6-8 mm	M12P-M03A-T-D8	163 003 411 3102
4	4-6 mm	M12P-M04A-T-D6	163 004 411 3101
	6-8 mm	M12P-M04A-T-D8	163 004 411 3102
5	4-6 mm	M12P-M05A-T-D6	163 005 411 3101
	6-8 mm	M12P-M05A-T-D8	163 005 411 3102
8	6-8 mm	M12P-M08A-T-D8	163 008 401 3003

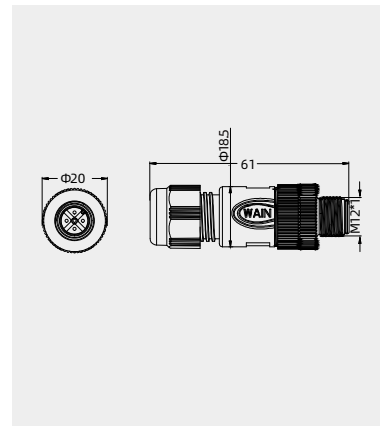

M12-A

## Male cable connector, plastic

locking system, solder



A-Code



3pin

4pin

5pin

8pin



12pin

Contacts	Cable outlet	Designation	Order No.
3	4-6 mm	M12P-MST03A-T-D6	163 003 413 3500
	6-8 mm	M12P-MST03A-T-D8	163 003 413 3501
4	4-6 mm	M12P-MST04A-T-D6	163 004 413 3502
	6-8 mm	M12P-MST04A-T-D8	163 004 413 3503
5	4-6 mm	M12P-MST05A-T-D6	163 005 413 3500
	6-8 mm	M12P-MST05A-T-D8	163 005 413 3501
8	4-6 mm	M12P-MST08A-T-D6	163 008 413 3502
	6-8 mm	M12P-MST08A-T-D8	163 008 413 3503
12	6-8 mm	M12P-MST12A-T-D8	163 012 413 3003

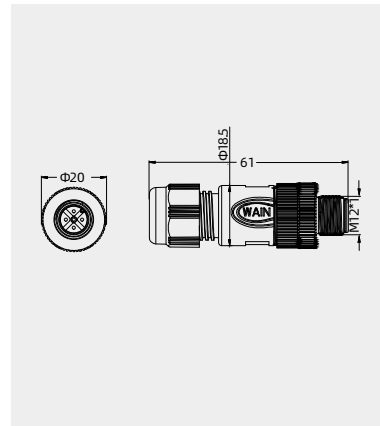

## Hexagonal driver



Description	Designation	Order No.
for 8 pin screw clamp connection	SW-1.27*47	198 001 003 0016

## M12-A Circular Connector

30/60/125/250V 1.5/2/4A

## Technical characteristics

	3-pole	4-pole	5-pole	8-pole	12-pole
Rated current (40°C)	4A	4A	4A	2A	1.5A
Rated voltage	250V	250V	125V	60V	30V
Rated impulse voltage	2500V	2500V	1500V	800V	800V
Pollution degree	3	3	3	3	3
Overvoltage categorie	II	II	II	II	II
Contact resistance	≤ 10 mΩ	≤ 10 mΩ	≤ 10 mΩ	≤ 10 mΩ	≤ 10 mΩ
Connector locking system	screw M12x1	screw M12x1	screw M12x1	screw M12x1	screw M12x1
Termination	screw/solder	screw/solder	screw/solder	screw/solder	solder
Wire gauge	max.0.75mm <sup>2</sup> (max.AWG18)	max.0.75mm <sup>2</sup> (max.AWG18)	max.0.75mm <sup>2</sup> (max.AWG18)	max.0.5mm <sup>2</sup> max.AWG20)	max.0.25mm <sup>2</sup> max.AWG24)
Cable outlet	4-6,6-8 mm	4-6,6-8 mm	4-6,6-8 mm	6-8 mm	6-8 mm
Degree of protection	IP67	IP67	IP67	IP67	IP67
Mechanical operation	> 100	> 100	> 100	> 100	> 100
Limiting temperature	-40°C ...+85°C	-40°C ...+85°C	-40°C ...+85°C	-40°C ...+85°C	-40°C ...+85°C
Material group	III	III	III	III	III
Material of contact	copper alloy	copper alloy	copper alloy	copper alloy	copper alloy
Contact plating	Au	Au	Au	Au	Au
Insulating material	PA	PA	PA	PA	PA
Material of housing	PA/PBT	PA/PBT	PA/PBT	PA/PBT	PA/PBT

## Straight cable connectors

Male cable connector,  
metal locking system,  
screw clamp connection  
**Recommended use**



A-Code



Contacts	Cable outlet	Designation	Order No.
3	4-6 mm	M12-M03A-T-D6	163 003 411 3001
	6-8 mm	M12-M03A-T-D8	163 003 411 3002
4	4-6 mm	M12-M04A-T-D6	163 004 411 3001
	6-8 mm	M12-M04A-T-D8	163 004 411 3002
5	4-6 mm	M12-M05A-T-D6	163 005 411 3001
	6-8 mm	M12-M05A-T-D8	163 005 411 3002
8	6-8 mm	M12-M08A-T-D8	163 008 411 3002

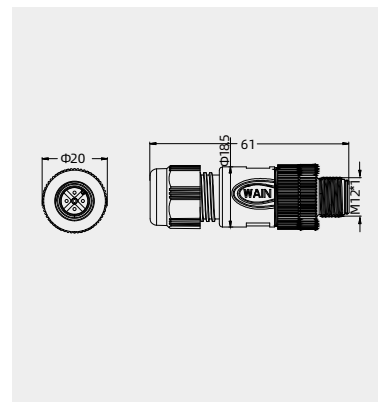

Male cable connector,  
metal locking system, solder  
**Recommended use**



A-Code



Contacts	Cable outlet	Designation	Order No.
3	4-6 mm	M12-MST03A-T-D6	163 003 413 3504
	6-8 mm	M12-MST03A-T-D8	163 003 413 3505
4	4-6 mm	M12-MST04A-T-D6	163 004 413 3501
	6-8 mm	M12-MST04A-T-D8	163 004 413 3510
5	4-6 mm	M12-MST05A-T-D6	163 005 413 3508
	6-8 mm	M12-MST05A-T-D8	163 005 413 3509
8	4-6 mm	M12-MST08A-T-D6	163 008 413 3500
	6-8 mm	M12-MST08A-T-D8	163 008 413 3501
12	6-8 mm	M12-MST12A-T-D8	163 012 413 3002

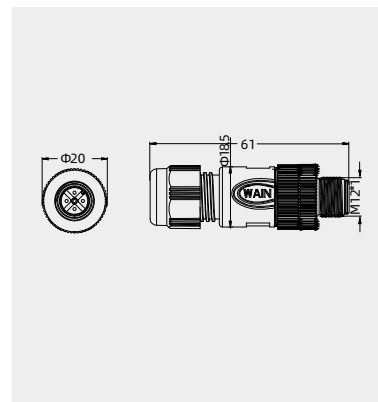

Hexagonal driver



Description	Designation	Order No.
for 8 pin screw clamp connection	SW-1.27*47	198 001 003 0016



## M12-A Circular Connector

30/60/125/250V 1.5/2/4A

## Technical characteristics

	3-pole	4-pole	5-pole	8-pole	12-pole
Rated current (40°C)	4A	4A	4A	2A	1.5A
Rated voltage	250V	250V	125V	60V	30V
Rated impulse voltage	2500V	2500V	1500V	800V	800V
Pollution degree	3	3	3	3	3
Overvoltage categorie	II	II	II	II	II
Contact resistance	≤ 10 mΩ	≤ 10 mΩ	≤ 10 mΩ	≤ 10 mΩ	≤ 10 mΩ
Connector locking system	screw M12x1	screw M12x1	screw M12x1	screw M12x1	screw M12x1
Termination	screw/solder	screw/solder	screw/solder	screw/solder	solder
Wire gauge	max.0.75mm <sup>2</sup> (max.AWG18)	max.0.75mm <sup>2</sup> (max.AWG18)	max.0.75mm <sup>2</sup> (max.AWG18)	max.0.5mm <sup>2</sup> max.AWG20)	max.0.25mm <sup>2</sup> max.AWG24)
Cable outlet	4-6,6-8 mm	4-6,6-8 mm	4-6,6-8 mm	6-8 mm	6-8 mm
Degree of protection	IP67	IP67	IP67	IP67	IP67
Mechanical operation	> 100	> 100	> 100	> 100	> 100
Limiting temperature	-40°C ...+85°C	-40°C ...+85°C	-40°C ...+85°C	-40°C ...+85°C	-40°C ...+85°C
Material group	III	III	III	III	III
Material of contact	copper alloy	copper alloy	copper alloy	copper alloy	copper alloy
Contact plating	Au	Au	Au	Au	Au
Insulating material	PA	PA	PA	PA	PA
Material of housing	PA/PBT	PA/PBT	PA/PBT	PA/PBT	PA/PBT

## Straight cable connectors

## Male cable connector, stainless steel

locking system, screw clamp connection,



A-Code



3pin

4pin

5pin

8pin



12pin

Contacts	Cable outlet	Designation	Order No.
3	4-6 mm	M12S-M03A-T-D6	163 003 401 3001
	6-8 mm	M12S-M03A-T-D8	163 003 401 3002
4	4-6 mm	M12S-M04A-T-D6	163 004 411 3201
	6-8 mm	M12S-M04A-T-D8	163 004 411 3202
5	4-6 mm	M12S-M05A-T-D6	163 005 411 3201
	6-8 mm	M12S-M05A-T-D8	163 005 411 3202
8	6-8 mm	M12S-M08A-T-D8	163 008 411 3202

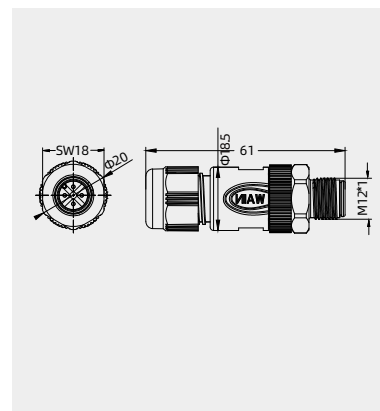

M12-A

## Male cable connector, stainless steel

locking system, solder



A-Code



3pin

4pin

5pin

8pin



12pin

Contacts	Cable outlet	Designation	Order No.
3	4-6 mm	M12S-MST03A-T-D6	163 003 413 3502
	6-8 mm	M12S-MST03A-T-D8	163 003 413 3503
4	4-6 mm	M12S-MST04A-T-D6	163 004 413 3504
	6-8 mm	M12S-MST04A-T-D8	163 004 413 3505
5	4-6 mm	M12S-MST05A-T-D6	163 005 413 3502
	6-8 mm	M12S-MST05A-T-D8	163 005 413 3503
8	4-6 mm	M12S-MST08A-T-D6	163 008 413 3504
	6-8 mm	M12S-MST08A-T-D8	163 008 413 3505
12	6-8 mm	M12S-MST12A-T-D8	163 012 413 3004

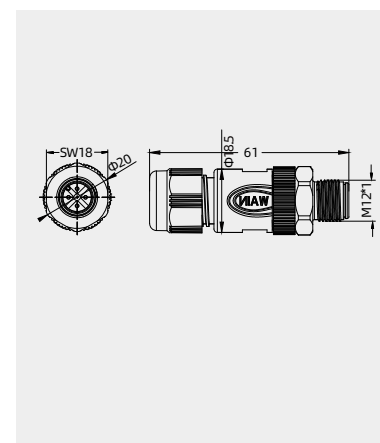

## Hexagonal driver



Description	Designation	Order No.
for 8 pin screw clamp connection	SW-1.27*47	198 001 003 0016

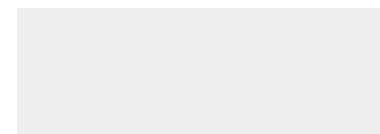

## M12-A Circular Connector

30/125/250V 1.5/2/8A

## Technical characteristics

	4-pole	5-pole	8-pole	12-pole
Rated current (40°C)	8A	Contacts:1-4 8A; Contacts:5 2A	Contacts: 2A	1.5A
Rated voltage	250V	125V	125V	30V
Rated impulse voltage	2500V	1500V	1500V9	800V
Pollution degree	3	3	3	3
Overvoltage categorie	II	II	II	II
Contact resistance	≤ 10 mΩ	≤ 10 mΩ	≤ 10 mΩ	≤ 10 mΩ
Connector locking system	screw M12x1	screw M12x1	screw M12x1	screw M12x1
Termination	screw/solder	screw/solder	screw/solder	solder
Wire gauge	max.1.5mm <sup>2</sup> (max.AWG16)	max.1.5mm <sup>2</sup> (max.AWG16)	max.1.5mm <sup>2</sup> (max.AWG16)	max.0.25mm <sup>2</sup> max.AWG24)
Cable outlet	8-10mm	8-10mm	8-10mm	6-8 mm
Degree of protection	IP67	IP67	IP67	IP67
Mechanical operation	> 100	> 100	> 100	> 100
Limiting temperature	-40°C ...+85°C	-40°C ...+85°C	-40°C ...+85°C	-40°C ...+85°C
Material group	II	II	II	III
Material of contact	copper alloy	copper alloy	copper alloy	copper alloy
Contact plating	Au	Au	Au	Au
Insulating material	PA	PA	PA	PA
Material of housing	PA/PBT	PA/PBT	PA/PBT	PA/PBT

## Straight cable connectors

Male cable connector,  
screw clamp connection

A-Code



Contacts	Cable outlet	Designation	Order No.
4	8-10 mm	M12-M04A-T-D10	163 004 411 3003
5	8-10 mm	M12-M05A-T-D10	163 005 411 3003
8	8-10 mm	M12-M08A-T-D10	163 008 401 3001

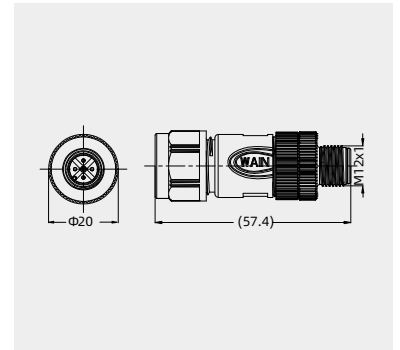

Male cable connector, solder



A-Code



Contacts	Cable outlet	Designation	Order No.
4	8-10 mm	M12-MST04A-T-D10	163 004 413 3506
5	8-10 mm	M12-MST05A-T-D10	163 005 413 3504
8	8-10 mm	M12-MST08A-T-D10	163 008 413 3506
12	8-10 mm	M12-MST12A-T-D10	163 012 413 3001

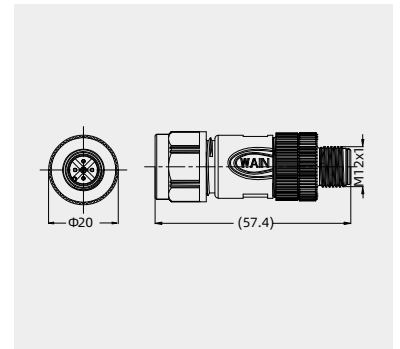

## M12-A Circular Connector

60/125/250V 2/4A

## Technical characteristics

	4-pole	5-pole	8-pole
Rated current (40°C)	4A	4A	2A
Rated voltage	250(125)V	125V	60V
Rated impulse voltage	2500V	1500V	800V
Pollution degree	3	3	3
Overvoltage categorie	II	II	II
Contact resistance	≤ 10 mΩ	≤ 10 mΩ	≤ 10 mΩ
Connector locking system	screw M12x1	screw M12x1	screw M12x1
Termination	screw/solder	screw/solder	screw/solder
Wire gauge	max.0.75mm <sup>2</sup> (max.AWG18)	max.0.75mm <sup>2</sup> (max.AWG18)	max.0.5mm <sup>2</sup> (max.AWG20)
Cable outlet	-	-	-
Degree of protection	IP67	IP67	IP67
Mechanical operation	> 100	> 100	> 100
Limiting temperature	-40°C ...+85°C	-40°C ...+85°C	-40°C ...+85°C
Material group	III	III	III
Material of contact	copper alloy	copper alloy	copper alloy
Contact plating	Au	Au	Au
Insulating material	PA	PA	PA
Material of housing	PA/PBT	PA/PBT	PA/PBT

## Straight cable duo connectors

Male cable connector, plastic locking system, screw clamp connection



A-Code



Contacts	Cable outlet	Designation	Order No.
4	2(2.1-3 mm or 4-5 mm)	M12P-M04A-T-2D5	163 004 411 3104
5	2(2.1-3 mm or 4-5 mm)	M12P-M05A-T-2D5	163 005 411 3104
8	2(2.1-3 mm or 4-5 mm)	M12P-M08A-T-2D5	163 008 401 3002

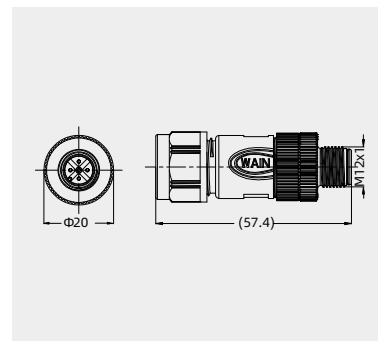

Male cable connector, plastic locking system, solder



A-Code



Contacts	Cable outlet	Designation	Order No.
4	2(2.1-3 mm or 4-5 mm)	M12P-MST04A-T-2D5	163 004 413 3507
5	2(2.1-3 mm or 4-5 mm)	M12P-MST05A-T-2D5	163 005 413 3505
8	2(2.1-3 mm or 4-5 mm)	M12P-MST08A-T-2D5	163 008 413 3507

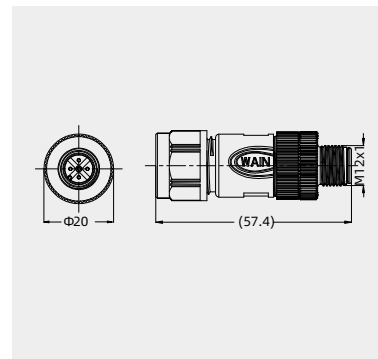

Hexagonal driver



Description	Designation	Order No.
for 8 pin screw clamp connection	SW-1.27*47	198 001 003 0016

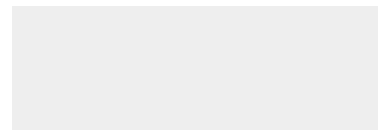

M12-A

## M12-A Circular Connector

60/125/250V 2/4A

## Technical characteristics

	4-pole	5-pole	8-pole
Rated current (40°C)	4A	4A	2A
Rated voltage	250(125)V	125V	60V
Rated impulse voltage	2500V	1500V	800V
Pollution degree	3	3	3
Overvoltage categorie	II	II	II
Contact resistance	≤ 10 mΩ	≤ 10 mΩ	≤ 10 mΩ
Connector locking system	screw M12x1	screw M12x1	screw M12x1
Termination	screw/solder	screw/solder	screw/solder
Wire gauge	max.0.75mm <sup>2</sup> (max.AWG18)	max.0.75mm <sup>2</sup> (max.AWG18)	max.0.5mm <sup>2</sup> (max.AWG20)
Cable outlet	-	-	-
Degree of protection	IP67	IP67	IP67
Mechanical operation	> 100	> 100	> 100
Limiting temperature	-40°C ...+85°C	-40°C ...+85°C	-40°C ...+85°C
Material group	III	III	III
Material of contact	copper alloy	copper alloy	copper alloy
Contact plating	Au	Au	Au
Insulating material	PA	PA	PA
Material of housing	PA/PBT	PA/PBT	PA/PBT

## Straight cable duo connectors

Male cable duo connector,  
metal locking system,  
screw clamp connection

Contacts	Cable outlet	Designation	Order No.
4	2(2.1-3 mm or 4-5 mm)	M12-M04A-T-2D5	163 004 411 3004
5	2(2.1-3 mm or 4-5 mm)	M12-M05A-T-2D5	163 005 411 3004
8	2(2.1-3 mm or 4-5 mm)	M12-M08A-T-2D5	163 008 411 3004



A-Code

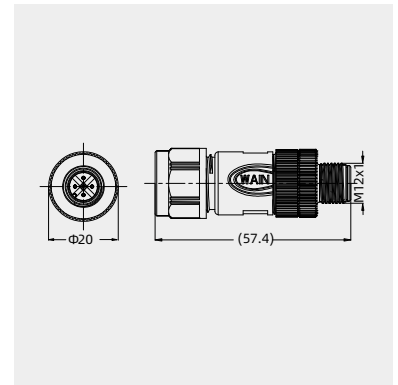

Male cable duo connector,  
metal locking system, solder

Contacts	Cable outlet	Designation	Order No.
4	2(2.1-3 mm or 4-5 mm)	M12-MST04A-T-2D5	163 004 413 3508
5	2(2.1-3 mm or 4-5 mm)	M12-MST05A-T-2D5	163 005 413 3506
8	2(2.1-3 mm or 4-5 mm)	M12-MST08A-T-2D5	163 008 413 3508



A-Code

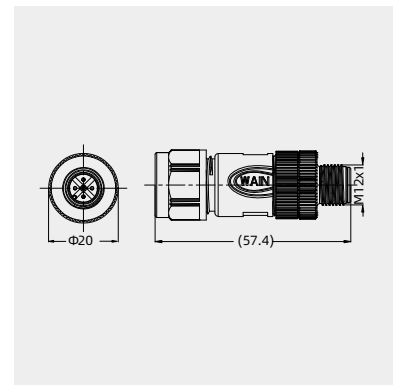

Hexagonal driver



Description	Designation	Order No.
for 8 pin screw clamp connection	SW-1.27*47	198 001 003 0016

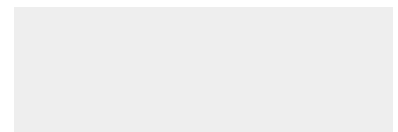

## M12-A Circular Connector

60/125/250V 2/4A

## Technical characteristics

	4-pole	5-pole	8-pole
Rated current (40°C)	4A	4A	2A
Rated voltage	250(125)V	125V	60V
Rated impulse voltage	2500V	1500V	800V
Pollution degree	3	3	3
Overvoltage categorie	II	II	II
Contact resistance	≤ 10 mΩ	≤ 10 mΩ	≤ 10 mΩ
Connector locking system	screw M12x1	screw M12x1	screw M12x1
Termination	screw/solder	screw/solder	screw/solder
Wire gauge	max.0.75mm <sup>2</sup> (max.AWG18)	max.0.75mm <sup>2</sup> (max.AWG18)	max.0.5mm <sup>2</sup> (max.AWG20)
Cable outlet	-	-	-
Degree of protection	IP67	IP67	IP67
Mechanical operation	> 100	> 100	> 100
Limiting temperature	-40°C ...+85°C	-40°C ...+85°C	-40°C ...+85°C
Material group	III	III	III
Material of contact	copper alloy	copper alloy	copper alloy
Contact plating	Au	Au	Au
Insulating material	PA	PA	PA
Material of housing	PA/PBT	PA/PBT	PA/PBT

## Straight cable duo connectors

## Male cable connector, stainless steel

locking system, screw clamp connection,



A-Code



Contacts	Cable outlet	Designation	Order No.
4	2(2.1-3 mm or4-5 mm)	M12S-M04A-T-2D5	163 004 411 3204
5	2(2.1-3 mm or4-5 mm)	M12S-M05A-T-2D5	163 005 411 3204
8	2(2.1-3 mm or4-5 mm)	M12S-M08A-T-2D5	163 008 411 3204

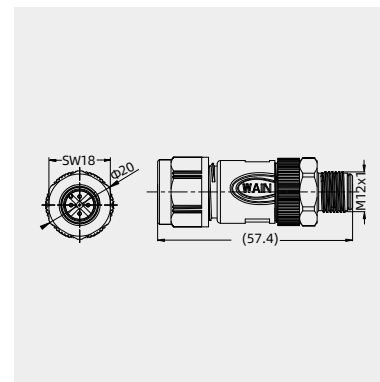

## Male cable connector, stainless steel

locking system, solder



A-Code

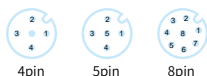

Contacts	Cable outlet	Designation	Order No.
4	2(2.1-3 mm or4-5 mm)	M12S-MST04A-T-2D5	163 004 413 3509
5	2(2.1-3 mm or4-5 mm)	M12S-MST05A-T-2D5	163 005 413 3507
8	2(2.1-3 mm or4-5 mm)	M12S-MST08A-T-2D5	163 008 413 3509

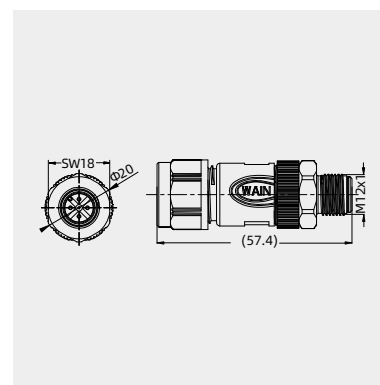

## Hexagonal driver



Description	Designation	Order No.
for 8 pin screw clamp connection	SW-1.27*47	198 001 003 0016

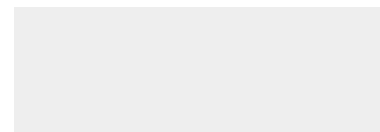

M12-A

## M12-A Circular Connector

30/60/125/250V 1.5/2/4A

### Technical characteristics

	3-pole	4-pole	5-pole	8-pole	12-pole
Rated current (40°C)	4A	4A	4A	2A	1.5A
Rated voltage	250V	250V	125V	60V	30V
Rated impulse voltage	2500V	2500V	1500V	800V	800V
Pollution degree	3	3	3	3	3
Overvoltage categorie	II	II	II	II	II
Contact resistance	≤ 10 mΩ	≤ 10 mΩ	≤ 10 mΩ	≤ 10 mΩ	≤ 10 mΩ
Connector locking system	screw M12x1	screw M12x1	screw M12x1	screw M12x1	screw M12x1
Termination	screw/solder	screw/solder	screw/solder	screw/solder	solder
Wire gauge	max.0.75mm <sup>2</sup> (max.AWG18)	max.0.75mm <sup>2</sup> (max.AWG18)	max.0.75mm <sup>2</sup> (max.AWG18)	max.0.5mm <sup>2</sup> (max.AWG20)	max.0.25mm <sup>2</sup> (max.AWG24)
Cable outlet	4-6,6-8mm	4-6,6-8mm	4-6,6-8mm	6-8,8-10mm	6-8,8-10mm
Degree of protection	IP67	IP67	IP67	IP67	IP67
Mechanical operation	> 100	> 100	> 100	> 100	> 100
Limiting temperature	-40°C ...+85°C	-40°C ...+85°C	-40°C ...+85°C	-40°C ...+85°C	-40°C ...+85°C
Material group	II	II	II	II	II
Material of contact	copper alloy	copper alloy	copper alloy	copper alloy	copper alloy
Contact plating	Au	Au	Au	Au	Au
Insulating material	PA	PA	PA	PA	PA
Material of housing	zinc diecasting nickel plated, brass nickel plated	zinc diecasting nickel plated, brass nickel plated	zinc diecasting nickel plated, brass nickel plated	zinc diecasting nickel plated, brass nickel plated	zinc diecasting nickel plated, brass nickel plated

### Straight cable connectors, shielded

Male cable connector, shielded,  
screw clamp connection,  
version with shielding ring,  
**Recommended use**



A-Code



Contacts	Cable outlet	Designation	Order No.
3	4-6 mm	M12-M03A-T-D6-SH	163 003 414 2002
	6-8 mm	M12-M03A-T-D8-SH	163 003 414 2003
	8-10 mm	M12-M03A-T-D10-SH	163 003 411 2500
4	4-6 mm	M12-M04A-T-D6-SH	163 004 411 2001
	6-8 mm	M12-M04A-T-D8-SH	163 004 411 2002
	8-10 mm	M12-M04A-T-D10-SH	163 004 411 2503
5	4-6 mm	M12-M05A-T-D6-SH	163 005 411 2001
	6-8 mm	M12-M05A-T-D8-SH	163 005 411 2002
	8-10 mm	M12-M05A-T-D10-SH	163 005 411 2502
8	6-8 mm	M12-M08A-T-D8-SH	163 008 411 2002
	8-10 mm	M12-M08A-T-D10-SH	163 008 411 2500

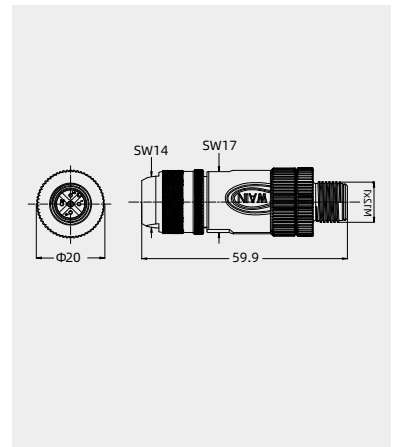

Male cable connector, shielded,  
solder, version with shielding ring,  
**Recommended use**



A-Code



Contacts	Cable outlet	Designation	Order No.
3	4-6 mm	M12-MST03A-T-D6-SH	163 003 413 2500
	6-8 mm	M12-MST03A-T-D8-SH	163 003 413 2501
4	4-6 mm	M12-MST04A-T-D6-SH	163 004 413 2001
	6-8 mm	M12-MST04A-T-D8-SH	163 004 413 2002
5	4-6 mm	M12-MST05A-T-D6-SH	163 005 413 2001
	6-8 mm	M12-MST05A-T-D8-SH	163 005 413 2002
8	4-6 mm	M12-MST08A-T-D6-SH	163 008 413 2500
	6-8 mm	M12-MST08A-T-D8-SH	163 008 413 2001
12	6-8 mm	M12-MST12A-T-D8-SH	163 012 413 2003
	8-10 mm	M12-MST12A-T-D10-SH	163 012 411 2500

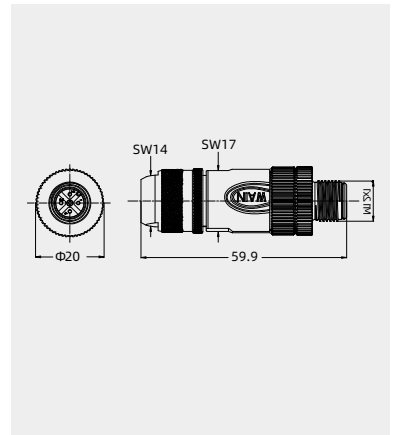

Hexagonal driver



Description	Designation	Order No.
for 8 pin screw clamp connection	SW-1.27*47	198 001 003 0016

## M12-A Circular Connector

125V 4A

## Technical characteristics

	5-pole
Rated current (40°C)	4A
Rated voltage	125V
Rated impulse voltage	1500V
Pollution degree	3
Overvoltage categorie	II
Contact resistance	≤ 10 mΩ
Connector locking system	screw M12x1
Termination	screw
Wire gauge	max.0.75mm <sup>2</sup> (max.AWG18)
Cable outlet	4-6,6-8mm
Degree of protection	IP67
Mechanical operation	> 100
Limiting temperature	-40°C ...+85°C
Material group	II
Material of contact	copper alloy
Contact plating	Au
Insulating material	PA
Material of housing	zinc diecasting nickel plated, brass nickel plated

## Straight cable connectors, shielded

Male cable connector,

Crimp terminal ,with shielding ring

Order crimp contacts separately

Contacts	Cable outlet	Designation	Order No.
5	6-8 mm	M12-MC05A-T-D8-SH	163 005 410 2500

A-Code



5pin

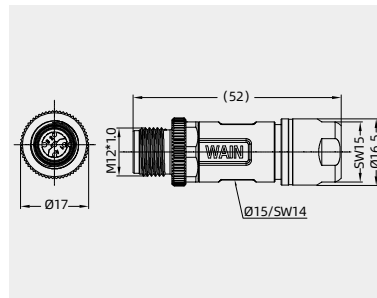

Male cable connector,

Crimp terminal ,with shielding ring

Order crimp contacts separately

Contacts	Cable outlet	Designation	Order No.
5	6-8 mm	M12-MC05A-CCT/R-M16-D8-SH	163 005 710 2001

A-Code



5pin

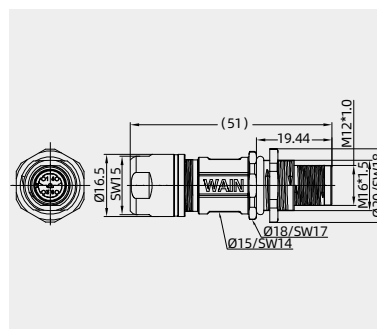

## Crimp contacts

Crimp contacts 5A

Contact resistance ≤ 3mΩ  
gold plated

Wire gauge(mm <sup>2</sup> )	Male	Order No.	Female	Order No.
0.09-0.25	CSGM-0.25	101 014 210 0101	CSGF-0.25	101 014 220 0101
0.13-0.33	CSGM-0.33	101 014 210 0201	CSGF-0.33	101 014 220 0201
0.33-0.52	CSGM-0.52	101 014 210 0501	CSGF-0.52	101 014 220 0501
0.52-0.82	CSGM-0.82	101 014 210 0701	CSGF-0.82	101 014 220 0701

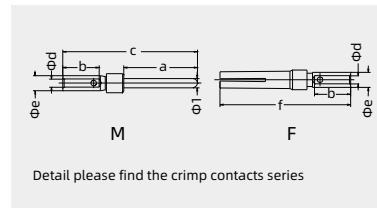

Detail please find the crimp contacts series

Tools

Crimping tool



Wire gauge	Designation	Order No.
0.09-0.82mm <sup>2</sup>	TL03	198 001 001 0002

Notes: The tools for crimp terminal may influence the product quality and stability. Please select the tools recognized by our company.

## M12-A Circular Connector

60/125/250V 2/4A

## Technical characteristics

	3-pole	4-pole	5-pole	8-pole
Rated current (40°C)	4A	4A	4A	2A
Rated voltage	250V	250V	125V	60V
Rated impulse voltage	2500V	2500V	1500V	800V
Pollution degree	3	3	3	3
Overvoltage categorie	II	II	II	II
Contact resistance	≤ 10 mΩ	≤ 10 mΩ	≤ 10 mΩ	≤ 10 mΩ
Connector locking system	screw M12x1	screw M12x1	screw M12x1	screw M12x1
Termination	screw/solder	screw/solder	screw/solder	solder
Wire gauge	max.0.75mm <sup>2</sup> (max.AWG18)	max.0.75mm <sup>2</sup> (max.AWG18)	max.0.75mm <sup>2</sup> (max.AWG18)	max.0.75mm <sup>2</sup> (max.AWG18)
Cable outlet	4-6-6-8 mm	4-6-6-8 mm	4-6,6-8 mm	4-6-6-8 mm
Degree of protection	IP67	IP67	IP67	IP67
Mechanical operation	> 100	> 100	> 100	> 100
Limiting temperature	-40°C ...+85°C	-40°C ...+85°C	-40°C ...+85°C	-40°C ...+85°C
Material group	II	II	II	II
Material of contact	copper alloy	copper alloy	copper alloy	copper alloy
Contact plating	Au	Au	Au	Au
Insulating material	PA	PA	PA	PA
Material of housing	PA/PBT	PA/PBT	PA/PBT	PA/PBT

## Angled cable connectors

Male cable connector, plastic locking system, screw clamp connection

Contacts	Cable outlet	Designation	Order No.
3	4-6 mm	M12P-M03A-S-D6	163 003 511 3101
	6-8 mm	M12P-M03A-S-D8	163 003 511 3102
4	4-6 mm	M12P-M04A-S-D6	163 004 511 3101
	6-8 mm	M12P-M04A-S-D8	163 004 511 3102
5	4-6 mm	M12P-M05A-S-D6	163 005 511 3101
	6-8 mm	M12P-M05A-S-D8	163 005 511 3102

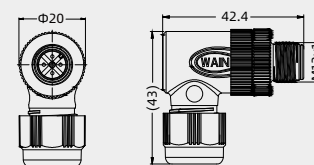

A-Code



Male cable connector, plastic locking system, solder

Contacts	Cable outlet	Designation	Order No.
3	4-6 mm	M12P-MST03A-S-D6	163 003 513 3500
	6-8 mm	M12P-MST03A-S-D8	163 003 513 3501
4	4-6 mm	M12P-MST04A-S-D6	163 004 513 3500
	6-8 mm	M12P-MST04A-S-D8	163 004 513 3501
5	4-6 mm	M12P-MST05A-S-D6	163 005 513 3500
	6-8 mm	M12P-MST05A-S-D8	163 005 513 3501
8	4-6 mm	M12P-MST08A-S-D6	163 008 513 3500
	6-8 mm	M12P-MST08A-S-D8	163 008 513 3501

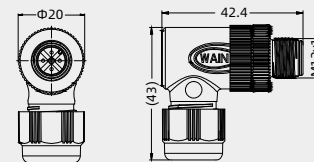

A-Code





## M12-A Circular Connector

60/125/250V 2/4A

## Technical characteristics

	3-pole	4-pole	5-pole	8-pole
Rated current (40°C)	4A	4A	4A	2A
Rated voltage	250V	250V	125V	60V
Rated impulse voltage	2500V	2500V	1500V	800V
Pollution degree	3	3	3	3
Overvoltage categorie	II	II	II	II
Contact resistance	≤ 10 mΩ	≤ 10 mΩ	≤ 10 mΩ	≤ 10 mΩ
Connector locking system	screw M12x1	screw M12x1	screw M12x1	screw M12x1
Termination	screw/solder	screw/solder	screw/solder	solder
Wire gauge	max.0.75mm <sup>2</sup> (max.AWG18)	max.0.75mm <sup>2</sup> (max.AWG18)	max.0.75mm <sup>2</sup> (max.AWG18)	max.0.75mm <sup>2</sup> (max.AWG18)
Cable outlet	4-6-6-8 mm	4-6-6-8 mm	4-6,6-8 mm	4-6,6-8 mm
Degree of protection	IP67	IP67	IP67	IP67
Mechanical operation	> 100	> 100	> 100	> 100
Limiting temperature	-40°C ...+85°C	-40°C ...+85°C	-40°C ...+85°C	-40°C ...+85°C
Material group	II	II	II	II
Material of contact	copper alloy	copper alloy	copper alloy	copper alloy
Contact plating	Au	Au	Au	Au
Insulating material	PA	PA	PA	PA
Material of housing	PA/PBT	PA/PBT	PA/PBT	PA/PBT

## Angled cable connectors

Male cable duo connector,  
metal locking system,  
screw clamp connection



A-Code



Contacts	Cable outlet	Designation	Order No.
3	4-6 mm	M12-M03A-S-D6	163 003 511 3001
	6-8 mm	M12-M03A-S-D8	163 003 511 3002
4	4-6 mm	M12-M04A-S-D6	163 004 511 3001
	6-8 mm	M12-M04A-S-D8	163 004 511 3002
5	4-6 mm	M12-M05A-S-D6	163 005 511 3001
	6-8 mm	M12-M05A-S-D8	163 005 511 3002

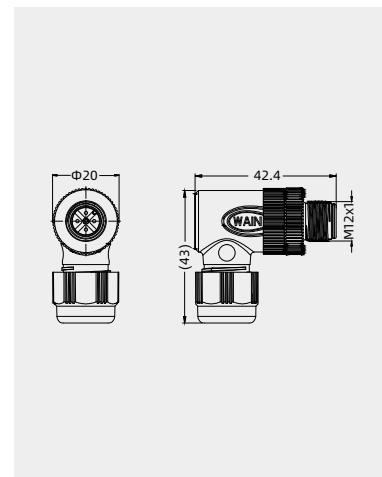

Male cable duo connector,  
metal locking system, solder



A-Code



Contacts	Cable outlet	Designation	Order No.
3	4-6 mm	M12-MST03A-S-D6	163 003 513 3502
	6-8 mm	M12-MST03A-S-D8	163 003 513 3503
4	4-6 mm	M12-MST04A-S-D6	163 004 513 3502
	6-8 mm	M12-MST04A-S-D8	163 004 513 3503
5	4-6 mm	M12-MST05A-S-D6	163 005 513 3502
	6-8 mm	M12-MST05A-S-D8	163 005 513 3503
8	4-6 mm	M12-MST08A-S-D6	163 008 513 3502
	6-8 mm	M12-MST08A-S-D8	163 008 513 3503

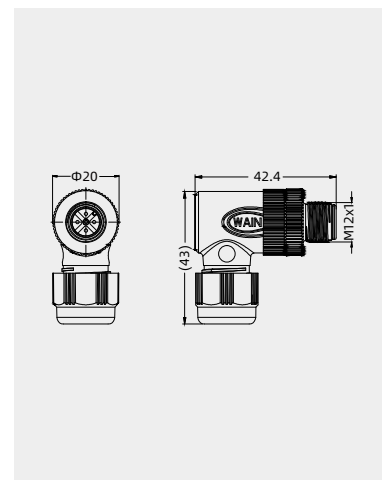

M12-A

## M12-A Circular Connector

60/125/250V 2/4A

## Technical characteristics

	3-pole	4-pole	5-pole	8-pole
Rated current (40°C)	4A	4A	4A	2A
Rated voltage	250V	250V	125V	60V
Rated impulse voltage	2500V	2500V	1500V	800V
Pollution degree	3	3	3	3
Overvoltage categorie	II	II	II	II
Contact resistance	≤ 10 mΩ	≤ 10 mΩ	≤ 10 mΩ	≤ 10 mΩ
Connector locking system	screw M12x1	screw M12x1	screw M12x1	screw M12x1
Termination	screw/solder	screw/solder	screw/solder	solder
Wire gauge	max.0.75mm <sup>2</sup> (max.AWG18)	max.0.75mm <sup>2</sup> (max.AWG18)	max.0.75mm <sup>2</sup> (max.AWG18)	max.0.75mm <sup>2</sup> (max.AWG18)
Cable outlet	4-6,6-8 mm	4-6,6-8 mm	4-6,6-8 mm	4-6,6-8 mm
Degree of protection	IP67	IP67	IP67	IP67
Mechanical operation	> 100	> 100	> 100	> 100
Limiting temperature	-40°C ...+85°C	-40°C ...+85°C	-40°C ...+85°C	-40°C ...+85°C
Material group	II	II	II	II
Material of contact	copper alloy	copper alloy	copper alloy	copper alloy
Contact plating	Au	Au	Au	Au
Insulating material	PA	PA	PA	PA
Material of housing	PA/PBT	PA/PBT	PA/PBT	PA/PBT

## Angled cable connectors

Male cable connector, stainless steel  
locking system, screw clamp connection

Contacts	Cable outlet	Designation	Order No.
3	4-6 mm	M12S-M03A-S-D6	163 003 414 1001
	6-8 mm	M12S-M03A-S-D8	163 003 514 1001
4	4-6 mm	M12S-M04A-S-D6	163 004 511 3201
	6-8 mm	M12S-M04A-S-D8	163 004 511 3202
5	4-6 mm	M12S-M05A-S-D6	163 005 511 3201
	6-8 mm	M12S-M05A-S-D8	163 005 511 3202

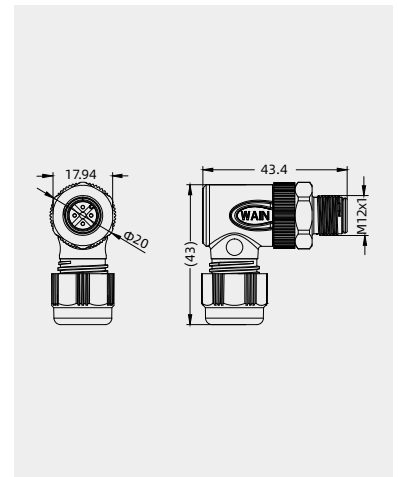

A-Code

Male cable connector, stainless steel  
locking system, solder

Contacts	Cable outlet	Designation	Order No.
3	4-6 mm	M12S-MST03A-S-D6	163 003 513 3504
	6-8 mm	M12S-MST03A-S-D8	163 003 513 3505
4	4-6 mm	M12S-MST04A-S-D6	163 004 513 3504
	6-8 mm	M12S-MST04A-S-D8	163 004 513 3505
5	4-6 mm	M12S-MST05A-S-D6	163 005 513 3504
	6-8 mm	M12S-MST05A-S-D8	163 005 513 3505
8	4-6 mm	M12S-MST08A-S-D6	163 008 513 3504
	6-8 mm	M12S-MST08A-S-D8	163 008 513 3505

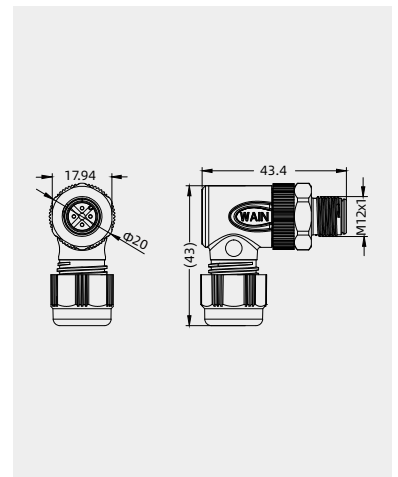

A-Code



## M12-A Circular Connector

125/250V 4A

## Technical characteristics

	4-pole	5-pole
Rated current (40°C)	4A	4A
Rated voltage	250V	125V
Rated impulse voltage	2500V	1500V
Pollution degree	3	3
Overvoltage categorie	II	II
Contact resistance	≤ 10 mΩ	≤ 10 mΩ
Connector locking system	screw M12x1	screw M12x1
Termination	screw/solder	screw/solder
Wire gauge	max.0.75mm <sup>2</sup> (max.AWG18)	max.0.75mm <sup>2</sup> (max.AWG18)
Cable outlet	2.1-3,4-5 mm	2.1-3,4-5 mm
Degree of protection	IP67	IP67
Mechanical operation	> 100	> 100
Limiting temperature	-40°C ...+85°C	-40°C ...+85°C
Material group	II	II
Material of contact	copper alloy	copper alloy
Contact plating	Au	Au
Insulating material	PA	PA
Material of housing	PA/PBT	PA/PBT

## Angled cable duo connectors

Male angled duo connector,  
plastic locking system,  
screw clamp connection



A-Code



Contacts	Cable outlet	Designation	Order No.
4	2(2.1-3 mm or 4-5 mm)	M12P-M04A-S-2D5	163 004 511 3104
5	2(2.1-3 mm or 4-5 mm)	M12P-M05A-S-2D5	163 005 511 3104

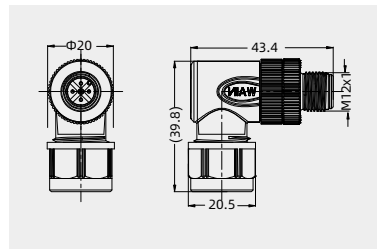

Male angled duo connector,  
plastic locking system, solder



A-Code

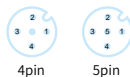

Contacts	Cable outlet	Designation	Order No.
4	2(2.1-3 mm or 4-5 mm)	M12P-MST04A-S-2D5	163 004 513 3506
5	2(2.1-3 mm or 4-5 mm)	M12P-MST05A-S-2D5	163 005 513 3506

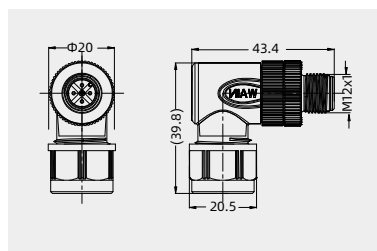

Male angled duo connector,  
metal locking system, screw  
clamp connection



A-Code

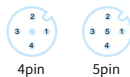

Contacts	Cable outlet	Designation	Order No.
4	2(2.1-3 mm or 4-5 mm)	M12-M04A-S-2D5	163 004 511 3004
5	2(2.1-3 mm or 4-5 mm)	M12-M05A-S-2D5	163 005 511 3004

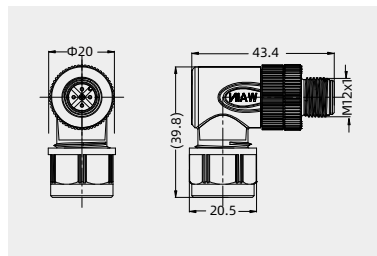

Male angled duo connector,  
metal locking system, solder



A-Code



Contacts	Cable outlet	Designation	Order No.
4	2(2.1-3 mm or 4-5 mm)	M12-MST04A-S-2D5	1630045133507
5	2(2.1-3 mm or 4-5 mm)	M12-MST05A-S-2D5	1630055133507

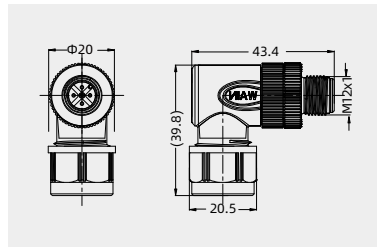

M12-A

## M12-A Circular Connector

60/125/250V 2/4A

## Technical characteristics

	3-pole	4-pole	5-pole	8-pole
Rated current (40°C)	4A	4A	4A	2A
Rated voltage	250V	250V	125V	60V
Rated impulse voltage	2500V	2500V	1500V	800V
Pollution degree	3	3	3	3
Overvoltage categorie	II	II	II	II
Contact resistance	≤ 10 mΩ	≤ 10 mΩ	≤ 10 mΩ	≤ 10 mΩ
Connector locking system	screw M12x1	screw M12x1	screw M12x1	screw M12x1
Termination	screw/solder	screw/solder	screw/solder	solder
Wire gauge	max.0.75mm <sup>2</sup> (max.AWG18)	max.0.75mm <sup>2</sup> (max.AWG18)	max.0.75mm <sup>2</sup> (max.AWG18)	max.0.75mm <sup>2</sup> (max.AWG18)
Cable outlet	4-6,6-8 mm	4-6,6-8 mm	4-6,6-8 mm	4-6,6-8 mm
Degree of protection	IP67	IP67	IP67	IP67
Mechanical operation	> 100	> 100	> 100	> 100
Limiting temperature	-40°C ...+85°C	-40°C ...+85°C	-40°C ...+85°C	-40°C ...+85°C
Material group	III	III	III	III
Material of contact	copper alloy	copper alloy	copper alloy	copper alloy
Contact plating	Au	Au	Au	Au
Insulating material	PA	PA	PA	PA
Material of housing	zinc diecasting nickel plated	zinc diecasting nickel plated	zinc diecasting nickel plated	zinc diecasting nickel plated

## Angled cable connectors, shielded

Male angled connector, shielded,  
screw clamp connection,  
version with shielding ring

Contacts	Cable outlet	Designation	Order No.
3	4-6 mm	M12-M03A-S-D6-SH	163 003 414 2001
	6-8 mm	M12-M03A-S-D8-SH	163 003 514 2001
4	4-6 mm	M12-M04A-S-D6-SH	163 004 511 2001
	6-8 mm	M12-M04A-S-D8-SH	163 004 511 2002
5	4-6 mm	M12-M05A-S-D6-SH	163 005 511 2001
	6-8 mm	M12-M05A-S-D8-SH	163 005 511 2002

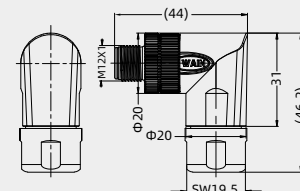

A-Code



Male angled connector, shielded,  
solder, version with shielding ring

Contacts	Cable outlet	Designation	Order No.
3	4-6 mm	M12-MST03A-S-D6-SH	163 003 513 2500
	6-8 mm	M12-MST03A-S-D8-SH	163 003 513 2501
4	4-6 mm	M12-MST04A-S-D6-SH	163 004 513 2500
	6-8 mm	M12-MST04A-S-D8-SH	163 004 513 2501
5	4-6 mm	M12-MST05A-S-D6-SH	163 005 513 2500
	6-8 mm	M12-MST05A-S-D8-SH	163 005 513 2501
8	4-6 mm	M12-MST08A-S-D6-SH	163 008 513 2500
	6-8 mm	M12-MST08A-S-D8-SH	163 008 513 2501

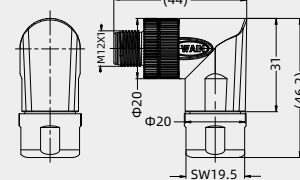

A-Code



## M12-A Circular Connector

30/60/125/250V 1.5/2/4A

## Technical characteristics

	3-pole	4-pole	5-pole	8-pole	12-pole
Rated current (40°C)	4A	4A	4A	2A	1.5A
Rated voltage	250V	250V	125V	60V	30V
Rated impulse voltage	2500V	2500V	1500V	800V	800V
Pollution degree	3	3	3	3	3
Overvoltage categorie	II	II	II	II	II
Contact resistance	≤ 10 mΩ	≤ 10 mΩ	≤ 10 mΩ	≤ 10 mΩ	≤ 10 mΩ
Connector locking system	screw M12x1	screw M12x1	screw M12x1	screw M12x1	screw M12x1
Termination	screw/solder	screw/solder	screw/solder	screw/solder	solder
Wire gauge	max.0.75mm <sup>2</sup> (max.AWG18)	max.0.75mm <sup>2</sup> (max.AWG18)	max.0.75mm <sup>2</sup> (max.AWG18)	max.0.5mm <sup>2</sup> max.AWG20)	max.0.25mm <sup>2</sup> max.AWG24)
Cable outlet	4-6,6-8 mm	4-6,6-8 mm	4-6,6-8 mm	6-8 mm	6-8 mm
Degree of protection	IP67	IP67	IP67	IP67	IP67
Mechanical operation	> 100	> 100	> 100	> 100	> 100
Limiting temperature	-40°C ...+85°C	-40°C ...+85°C	-40°C ...+85°C	-40°C ...+85°C	-40°C ...+85°C
Material group	III	III	III	III	III
Material of contact	copper alloy	copper alloy	copper alloy	copper alloy	copper alloy
Contact plating	Au	Au	Au	Au	Au
Insulating material	PA	PA	PA	PA	PA
Material of housing	PA/PBT	PA/PBT	PA/PBT	PA/PBT	PA/PBT

## Straight cable connectors

Female cable connector,  
plastic locking system,  
screw clamp connection



A-Code



12pin

Contacts	Cable outlet	Designation	Order No.
3	4-6 mm	M12P-F03A-T-D6	163 003 421 3101
	6-8 mm	M12P-F03A-T-D8	163 003 421 3102
4	4-6 mm	M12P-F04A-T-D6	163 004 421 3101
	6-8 mm	M12P-F04A-T-D8	163 004 421 3102
5	4-6 mm	M12P-F05A-T-D6	163 005 421 3101
	6-8 mm	M12P-F05A-T-D8	163 005 421 3102
8	6-8 mm	M12P-F08A-T-D8	163 008 424 3002

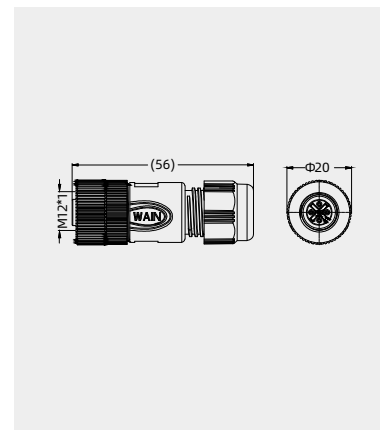

M12-A

Female cable connector,  
plastic locking system, solder



A-Code

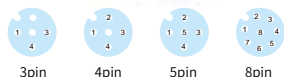

12pin

Contacts	Cable outlet	Designation	Order No.
3	4-6 mm	M12P-FST03A-T-D6	163 003 423 3500
	6-8 mm	M12P-FST03A-T-D8	163 003 423 3501
4	4-6 mm	M12P-FST04A-T-D6	163 004 423 3500
	6-8 mm	M12P-FST04A-T-D8	163 004 423 3501
5	4-6 mm	M12P-FST05A-T-D6	163 005 423 3500
	6-8 mm	M12P-FST05A-T-D8	163 005 423 3501
8	4-6 mm	M12P-FST08A-T-D6	163 008 423 3502
	6-8 mm	M12P-FST08A-T-D8	163 008 423 3503
12	6-8 mm	M12P-FST12A-T-D8	163 012 423 3003

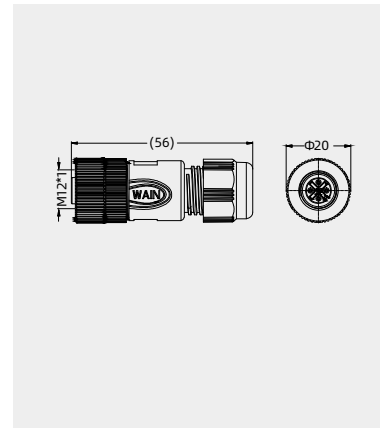

## Hexagonal driver



Description	Designation	Order No.
for 8 pin screw clamp connection	SW-1.27*47	198 001 003 0016

## M12-A Circular Connector

30/60/125/250V 1.5/2/4A

## Technical characteristics

	3-pole	4-pole	5-pole	8-pole	12-pole
Rated current (40°C)	4A	4A	4A	2A	1.5A
Rated voltage	250V	250V	125V	60V	30V
Rated impulse voltage	2500V	2500V	1500V	800V	800V
Pollution degree	3	3	3	3	3
Overvoltage categorie	II	II	II	II	II
Contact resistance	≤ 10 mΩ	≤ 10 mΩ	≤ 10 mΩ	≤ 10 mΩ	≤ 10 mΩ
Connector locking system	screw M12x1	screw M12x1	screw M12x1	screw M12x1	screw M12x1
Termination	screw/solder	screw/solder	screw/solder	screw/solder	solder
Wire gauge	max.0.75mm <sup>2</sup> (max.AWG18)	max.0.75mm <sup>2</sup> (max.AWG18)	max.0.75mm <sup>2</sup> (max.AWG18)	max.0.5mm <sup>2</sup> max.AWG20)	max.0.25mm <sup>2</sup> max.AWG24)
Cable outlet	4-6,6-8 mm	4-6,6-8 mm	4-6,6-8 mm	6-8 mm	6-8 mm
Degree of protection	IP67	IP67	IP67	IP67	IP67
Mechanical operation	> 100	> 100	> 100	> 100	> 100
Limiting temperature	-40°C ...+85°C	-40°C ...+85°C	-40°C ...+85°C	-40°C ...+85°C	-40°C ...+85°C
Material group	III	III	III	III	III
Material of contact	copper alloy	copper alloy	copper alloy	copper alloy	copper alloy
Contact plating	Au	Au	Au	Au	Au
Insulating material	PA	PA	PA	PA	PA
Material of housing	PA/PBT	PA/PBT	PA/PBT	PA/PBT	PA/PBT

## Straight cable connectors

Female cable connector,  
metal locking system,  
screw clamp connection  
**Recommended use**



A-Code



3pin 4pin 5pin 8pin



12pin

Contacts	Cable outlet	Designation	Order No.
3	4-6 mm	M12-F03A-T-D6	163 003 421 3001
	6-8 mm	M12-F03A-T-D8	163 003 421 3002
4	4-6 mm	M12-F04A-T-D6	163 004 421 3001
	6-8 mm	M12-F04A-T-D8	163 004 421 3002
5	4-6 mm	M12-F05A-T-D6	163 005 421 3001
	6-8 mm	M12-F05A-T-D8	163 005 421 3002
8	6-8 mm	M12-F08A-T-D8	163 008 421 3002

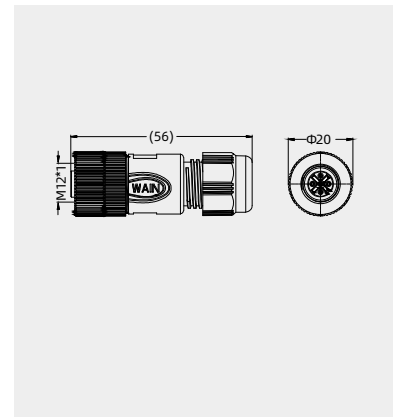

Female cable connector,  
metal locking system, solder  
**Recommended use**



A-Code



3pin 4pin 5pin 8pin



12pin

Contacts	Cable outlet	Designation	Order No.
3	4-6 mm	M12-FST03A-T-D6	163 003 423 3504
	6-8 mm	M12-FST03A-T-D8	163 003 423 3505
4	4-6 mm	M12-FST04A-T-D6	163 004 423 3508
	6-8 mm	M12-FST04A-T-D8	163 004 423 3509
5	4-6 mm	M12-FST05A-T-D6	163 005 423 3508
	6-8 mm	M12-FST05A-T-D8	163 005 423 3509
8	4-6 mm	M12-FST08A-T-D6	163 008 423 3510
	6-8 mm	M12-FST08A-T-D8	163 008 423 3501
12	6-8 mm	M12-FST12A-T-D8	163 012 423 3002

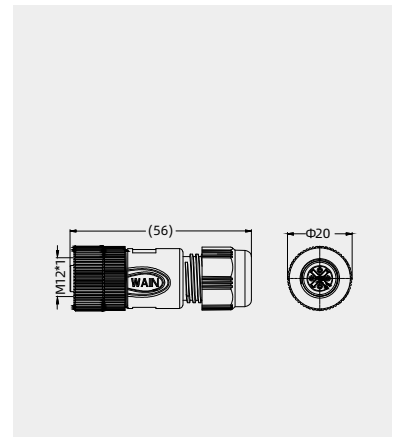

## Hexagonal driver



Description	Designation	Order No.
for 8 pin screw clamp connection	SW-1.27*47	198 001 003 0016

## M12-A Circular Connector

30/60/125/250V 1.5/2/4A

## Technical characteristics

	3-pole	4-pole	5-pole	8-pole	12-pole
Rated current (40°C)	4A	4A	4A	2A	1.5A
Rated voltage	250V	250V	125V	60V	30V
Rated impulse voltage	2500V	2500V	1500V	800V	800V
Pollution degree	3	3	3	3	3
Overvoltage categorie	II	II	II	II	II
Contact resistance	≤ 10 mΩ	≤ 10 mΩ	≤ 10 mΩ	≤ 10 mΩ	≤ 10 mΩ
Connector locking system	screw M12x1	screw M12x1	screw M12x1	screw M12x1	screw M12x1
Termination	screw/solder	screw/solder	screw/solder	screw/solder	solder
Wire gauge	max.0.75mm <sup>2</sup> (max.AWG18)	max.0.75mm <sup>2</sup> (max.AWG18)	max.0.75mm <sup>2</sup> (max.AWG18)	max.0.5mm <sup>2</sup> max.AWG20)	max.0.25mm <sup>2</sup> max.AWG24)
Cable outlet	4-6,6-8 mm	4-6,6-8 mm	4-6,6-8 mm	6-8 mm	6-8 mm
Degree of protection	IP67	IP67	IP67	IP67	IP67
Mechanical operation	> 100	> 100	> 100	> 100	> 100
Limiting temperature	-40°C ...+85°C	-40°C ...+85°C	-40°C ...+85°C	-40°C ...+85°C	-40°C ...+85°C
Material group	III	III	III	III	III
Material of contact	copper alloy	copper alloy	copper alloy	copper alloy	copper alloy
Contact plating	Au	Au	Au	Au	Au
Insulating material	PA	PA	PA	PA	PA
Material of housing	PA/PBT	PA/PBT	PA/PBT	PA/PBT	PA/PBT

## Straight cable connectors

Female cable connector,  
stainless steel locking system,  
screw clamp connection,



A-Code



Contacts	Cable outlet	Designation	Order No.
3	4-6 mm	M12S-F03A-T-D6	163 003 424 1001
	6-8 mm	M12S-F03A-T-D8	163 003 424 1002
4	4-6 mm	M12S-F04A-T-D6	163 004 421 3201
	6-8 mm	M12S-F04A-T-D8	163 004 421 3202
5	4-6 mm	M12S-F05A-T-D6	163 005 421 3201
	6-8 mm	M12S-F05A-T-D8	163 005 421 3202
8	6-8 mm	M12S-F08A-T-D8	163 008 421 3202

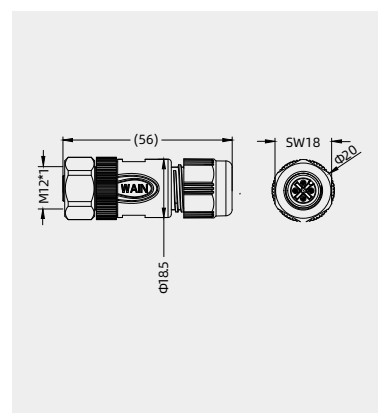

Female cable connector,  
stainless steel locking system,solder



A-Code

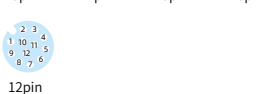

Contacts	Cable outlet	Designation	Order No.
3	4-6 mm	M12S-FST03A-T-D6	163 003 423 3502
	6-8 mm	M12S-FST03A-T-D8	163 003 4233503
4	4-6 mm	M12S-FST04A-T-D6	163 004 423 3502
	6-8 mm	M12S-FST04A-T-D8	163 004 423 3503
5	4-6 mm	M12S-FST05A-T-D6	163 005 423 3502
	6-8 mm	M12S-FST05A-T-D8	163 005 423 3503
8	4-6 mm	M12S-FST08A-T-D6	163 008 423 3509
	6-8 mm	M12S-FST08A-T-D8	163 008 423 3504
12	6-8 mm	M12S-FST12A-T-D8	163 012 423 3004

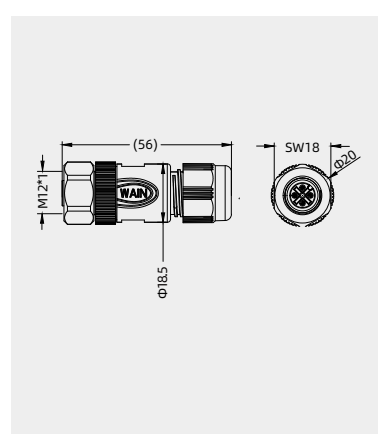

## Hexagonal driver



Description	Designation	Order No.
for 8 pin screw clamp connection	SW-1.27*47	198 001 003 0016

## M12-A Circular Connector

30/125/250V 1.5/2/8A

## Technical characteristics

	4-pole	5-pole	8-pole	12-pole
Rated current (40°C)	8A	Contacts:1-4 8A; Contacts:5 2A	Contacts: 2A	1.5A
Rated voltage	250V	125V	125V	30V
Rated impulse voltage	2500V	1500V	1500V9	800V
Pollution degree	3	3	3	3
Overvoltage categorie	II	II	II	II
Contact resistance	≤ 10 mΩ	≤ 10 mΩ	≤ 10 mΩ	≤ 10 mΩ
Connector locking system	screw M12x1	screw M12x1	screw M12x1	screw M12x1
Termination	screw/solder	screw/solder	screw/solder	solder
Wire gauge	max.1.5mm <sup>2</sup> (max.AWG16)	max.1.5mm <sup>2</sup> (max.AWG16)	max.1.5mm <sup>2</sup> (max.AWG16)	max.0.25mm <sup>2</sup> max.AWG24)
Cable outlet	8-10mm	8-10mm	8-10mm	6-8 mm
Degree of protection	IP67	IP67	IP67	IP67
Mechanical operation	> 100	> 100	> 100	> 100
Limiting temperature	-40°C ...+85°C	-40°C ...+85°C	-40°C ...+85°C	-40°C ...+85°C
Material group	II	II	II	III
Material of contact	copper alloy	copper alloy	copper alloy	copper alloy
Contact plating	Au	Au	Au	Au
Insulating material	PA	PA	PA	PA
Material of housing	PA/PBT	PA/PBT	PA/PBT	PA/PBT

## Straight cable connectors

Female cable connector, Power,  
screw clamp with ferules

A-Code

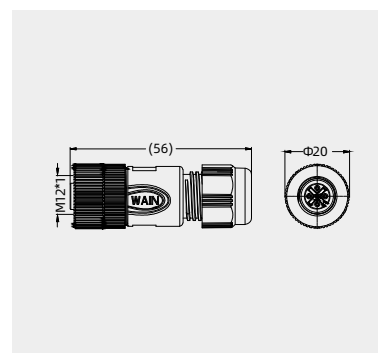

Contacts	Cable outlet	Designation	Order No.
4	8-10 mm	M12-F04A-T-D10	163 004 421 3003
5	8-10 mm	M12-F05A-T-D10	163 005 421 3003
8	8-10 mm	M12-F08A-T-D10	163 008 424 1002

Female cable connector, Power,  
solder

A-Code



Contacts	Cable outlet	Designation	Order No.
4	8-10 mm	M12-FST04A-T-D10	163 004 423 3504
5	8-10 mm	M12-FST05A-T-D10	163 005 423 3504
8	8-10 mm	M12-FST08A-T-D10	163 008 423 3505
12	8-10 mm	M12-FST12A-T-D10	163 012 423 3001

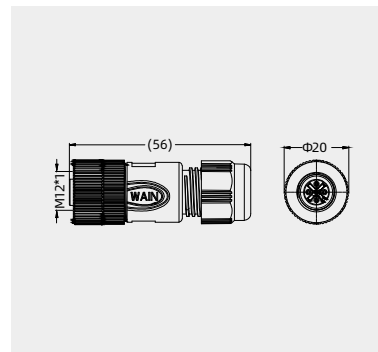



## M12-A Circular Connector

60/125/250V 2/4A

## Technical characteristics

	4-pole	5-pole	8-pole
Rated current (40°C)	4A	4A	2A
Rated voltage	250(125)V	125V	60V
Rated impulse voltage	2500V	1500V	800V
Pollution degree	3	3	3
Overvoltage categorie	II	II	II
Contact resistance	≤ 10 mΩ	≤ 10 mΩ	≤ 10 mΩ
Connector locking system	screw M12x1	screw M12x1	screw M12x1
Termination	screw/solder	screw/solder	screw/solder
Wire gauge	max.0.75mm <sup>2</sup> (max.AWG18)	max.0.75mm <sup>2</sup> (max.AWG18)	max.0.5mm <sup>2</sup> (max.AWG20)
Cable outlet	-	-	-
Degree of protection	IP67	IP67	IP67
Mechanical operation	> 100	> 100	> 100
Limiting temperature	-40°C ...+85°C	-40°C ...+85°C	-40°C ...+85°C
Material group	III	III	III
Material of contact	copper alloy	copper alloy	copper alloy
Contact plating	Au	Au	Au
Insulating material	PA	PA	PA
Material of housing	PA/PBT	PA/PBT	PA/PBT

## Straight cable duo connectors

Female cable connector,  
plastic locking system,  
screw clamp connection



A-Code



4pin 5pin 8pin

Contacts	Cable outlet	Designation	Order No.
4	2(2.1-3 mm or4-5 mm)	M12P-F04A-T-2D5	163 004 421 3104
5	2(2.1-3 mm or4-5 mm)	M12P-F05A-T-2D5	163 005 421 3104
8	2(2.1-3 mm or4-5 mm)	M12P-F08A-T-2D5	163 008 424 3001

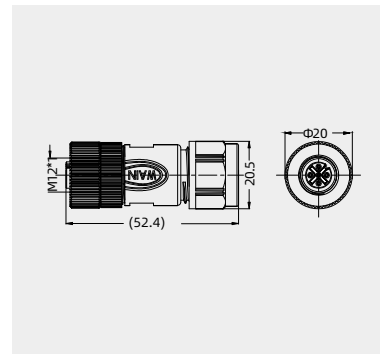

Female cable connector,  
plastic locking system,solder



A-Code



4pin 5pin 8pin

Contacts	Cable outlet	Designation	Order No.
4	2(2.1-3 mm or4-5 mm)	M12P-FST04A-T-2D5	163 004 423 3505
5	2(2.1-3 mm or4-5 mm)	M12P-FST05A-T-2D5	163 005 423 3505
8	2(2.1-3 mm or4-5 mm)	M12P-FST08A-T-2D5	163 008 423 3506

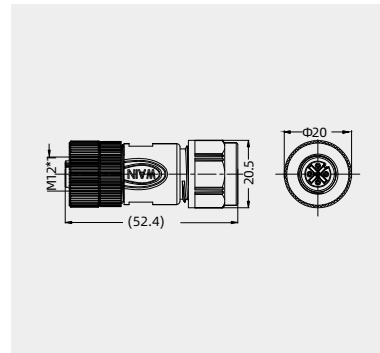

Hexagonal driver



Description	Designation	Order No.
for 8 pin screw clamp connection	SW-1.27*47	198 001 003 0016

## M12-A Circular Connector

60/125/250V 2/4A

## Technical characteristics

	4-pole	5-pole	8-pole
Rated current (40°C)	4A	4A	2A
Rated voltage	250(125)V	125V	60V
Rated impulse voltage	2500V	1500V	800V
Pollution degree	3	3	3
Overvoltage categorie	II	II	II
Contact resistance	≤ 10 mΩ	≤ 10 mΩ	≤ 10 mΩ
Connector locking system	screw M12x1	screw M12x1	screw M12x1
Termination	screw/solder	screw/solder	screw/solder
Wire gauge	max.0.75mm <sup>2</sup> (max.AWG18)	max.0.75mm <sup>2</sup> (max.AWG18)	max.0.5mm <sup>2</sup> (max.AWG20)
Cable outlet	-	-	-
Degree of protection	IP67	IP67	IP67
Mechanical operation	> 100	> 100	> 100
Limiting temperature	-40°C ...+85°C	-40°C ...+85°C	-40°C ...+85°C
Material group	III	III	III
Material of contact	copper alloy	copper alloy	copper alloy
Contact plating	Au	Au	Au
Insulating material	PA	PA	PA
Material of housing	PA/PBT	PA/PBT	PA/PBT

## Straight cable duo connectors

Female cable duo connector,  
metal locking system,  
screw clamp connection

Contacts	Cable outlet	Designation	Order No.
4	2(2.1-3 mm or4-5 mm)	M12-F04A-T-2D5	163 004 421 3105
5	2(2.1-3 mm or4-5 mm)	M12-F05A-T-2D5	163 005 421 3105
8	2(2.1-3 mm or4-5 mm)	M12-F08A-T-2D5	163 008 424 1001



A-Code

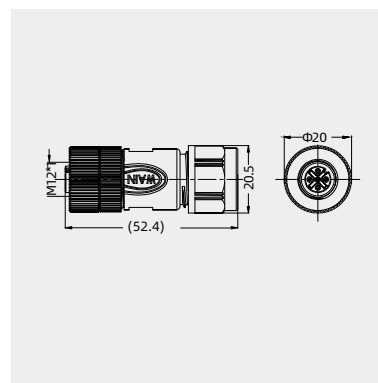
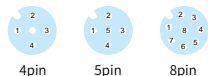

Female cable duo connector,  
metal locking system,solder

Contacts	Cable outlet	Designation	Order No.
4	2(2.1-3 mm or4-5 mm)	M12-FST04A-T-2D5	163 004 423 3506
5	2(2.1-3 mm or4-5 mm)	M12-FST05A-T-2D5	163 005 423 3506
8	2(2.1-3 mm or4-5 mm)	M12-FST08A-T-2D5	163 008 423 3507



A-Code

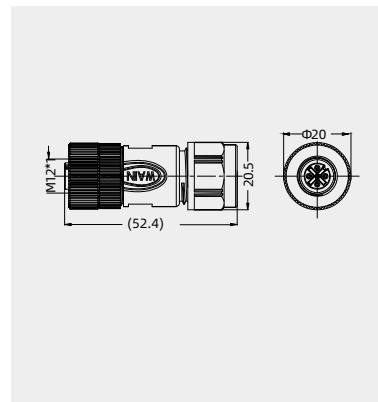
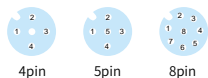

Hexagonal driver



Description	Designation	Order No.
for 8 pin screw clamp connection	SW-1.27*47	198 001 003 0016

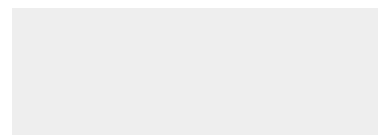

## M12-A Circular Connector

60/125/250V 2/4A

## Technical characteristics

	4-pole	5-pole	8-pole
Rated current (40°C)	4A	4A	2A
Rated voltage	250(125)V	125V	60V
Rated impulse voltage	2500V	1500V	800V
Pollution degree	3	3	3
Overvoltage categorie	II	II	II
Contact resistance	≤ 10 mΩ	≤ 10 mΩ	≤ 10 mΩ
Connector locking system	screw M12x1	screw M12x1	screw M12x1
Termination	screw/solder	screw/solder	screw/solder
Wire gauge	max.0.75mm <sup>2</sup> (max.AWG18)	max.0.75mm <sup>2</sup> (max.AWG18)	max.0.5mm <sup>2</sup> (max.AWG20)
Cable outlet	-	-	-
Degree of protection	IP67	IP67	IP67
Mechanical operation	> 100	> 100	> 100
Limiting temperature	-40°C ...+85°C	-40°C ...+85°C	-40°C ...+85°C
Material group	III	III	III
Material of contact	copper alloy	copper alloy	copper alloy
Contact plating	Au	Au	Au
Insulating material	PA	PA	PA
Material of housing	PA/PBT	PA/PBT	PA/PBT

## Straight cable duo connectors

Female cable connector,  
stainless steel locking system,  
screw clamp connection,



A-Code



Contacts	Cable outlet	Designation	Order No.
4	2(2.1-3 mm or4-5 mm)	M12S-F04A-T-2D5	163 004 421 3204
5	2(2.1-3 mm or4-5 mm)	M12S-F05A-T-2D5	163 005 421 3204
8	2(2.1-3 mm or4-5 mm)	M12S-F08A-T-2D5	163 008 421 3204

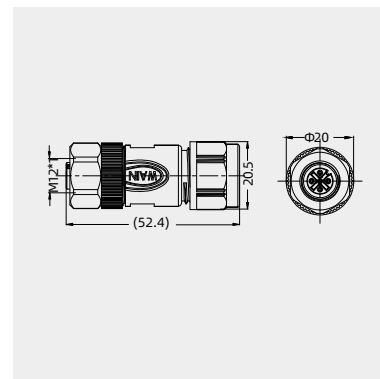

Female cable connector,  
stainless steel locking system,  
solder



A-Code



Contacts	Cable outlet	Designation	Order No.
4	2(2.1-3 mm or4-5 mm)	M12S-FST04A-T-2D5	163 004 423 3507
5	2(2.1-3 mm or4-5 mm)	M12S-FST05A-T-2D5	163 005 423 3507
8	2(2.1-3 mm or4-5 mm)	M12S-FST08A-T-2D5	163 008 423 3508

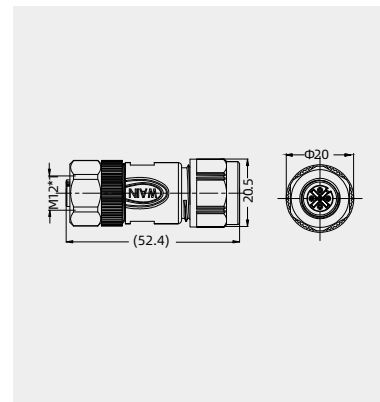

Hexagonal driver



Description	Designation	Order No.
for 8 pin screw clamp connection	SW-1.27*47	198 001 003 0016

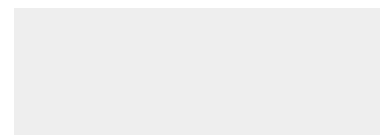

M12-A

## M12-A Circular Connector

125/250V 4A

## Technical characteristics

	4-pole	5-pole
Rated current (40°C)	4A	4A
Rated voltage	250V	125V
Rated impulse voltage	2500V	1500V
Pollution degree	3	3
Overvoltage categorie	II	II
Contact resistance	≤ 10 mΩ	≤ 10 mΩ
Connector locking system	screw M12x1	screw M12x1
Termination	screw/solder	screw/solder
Wire gauge	max.0.75mm <sup>2</sup> (max.AWG18)	max.0.75mm <sup>2</sup> (max.AWG18)
Cable outlet	2.1-3,4-5 mm	2.1-3,4-5 mm
Degree of protection	IP67	IP67
Mechanical operation	> 100	> 100
Limiting temperature	-40°C ...+85°C	-40°C ...+85°C
Material group	II	II
Material of contact	copper alloy	copper alloy
Contact plating	Au	Au
Insulating material	PA	PA
Material of housing	PA/PBT	PA/PBT

## Angled cable duo connectors

Female angled duo connector,  
plastic locking system,  
screw clamp connection



A-Code



4pin 5pin

Contacts	Cable outlet	Designation	Order No.
4	2(2.1-3 mm or 4-5 mm)	M12P-F04A-S-2D5	163 004 502 3001
5	2(2.1-3 mm or 4-5 mm)	M12P-F05A-S-2D5	163 005 502 3001

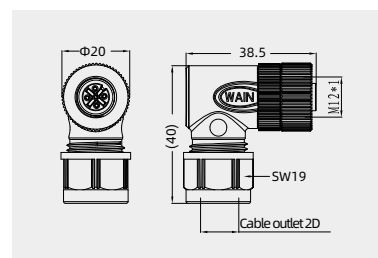

Female angled duo connector,  
plastic locking system, solder



A-Code

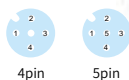

4pin 5pin

Contacts	Cable outlet	Designation	Order No.
4	2(2.1-3 mm or 4-5 mm)	M12P-FST04A-S-2D5	163 004 523 3506
5	2(2.1-3 mm or 4-5 mm)	M12P-FST05A-S-2D5	163 005 523 3506

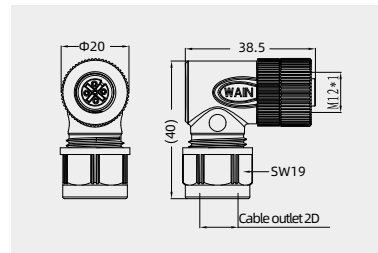

Female angled duo connector,  
metal locking system,  
screw clamp connection



A-Code



4pin 5pin

Contacts	Cable outlet	Designation	Order No.
4	2(2.1-3 mm or 4-5 mm)	M12-F04A-S-2D5	163 004 502 1001
5	2(2.1-3 mm or 4-5 mm)	M12-F05A-S-2D5	163 005 502 1001

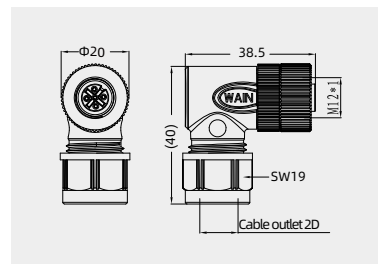

Female angled duo connector,  
metal locking system, solder



A-Code

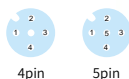

4pin 5pin

Contacts	Cable outlet	Designation	Order No.
4	2(2.1-3 mm or 4-5 mm)	M12-FST04A-S-2D5	163 004 523 3507
5	2(2.1-3 mm or 4-5 mm)	M12-FST05A-S-2D5	163 005 523 3507

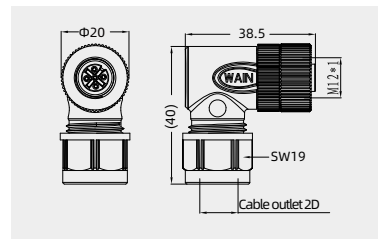

## M12-A Circular Connector

30/60/125/250V 1.5/2/4A

## Technical characteristics

	3-pole	4-pole	5-pole	8-pole	12-pole
Rated current (40°C)	4A	4A	4A	2A	1.5A
Rated voltage	250V	250V	125V	60V	30V
Rated impulse voltage	2500V	2500V	1500V	800V	800V
Pollution degree	3	3	3	3	3
Overvoltage categorie	II	II	II	II	II
Contact resistance	≤ 10 mΩ	≤ 10 mΩ	≤ 10 mΩ	≤ 10 mΩ	≤ 10 mΩ
Connector locking system	screw M12x1	screw M12x1	screw M12x1	screw M12x1	screw M12x1
Termination	screw/solder	screw/solder	screw/solder	screw/solder	solder
Wire gauge	max.0.75mm <sup>2</sup> (max.AWG18)	max.0.75mm <sup>2</sup> (max.AWG18)	max.0.75mm <sup>2</sup> (max.AWG18)	max.0.5mm <sup>2</sup> (max.AWG20)	max.0.25mm <sup>2</sup> (max.AWG24)
Cable outlet	4-6,6-8mm	4-6,6-8mm	4-6,6-8mm	6-8,8-10mm	6-8,8-10mm
Degree of protection	IP67	IP67	IP67	IP67	IP67
Mechanical operation	> 100	> 100	> 100	> 100	> 100
Limiting temperature	-40°C ...+85°C	-40°C ...+85°C	-40°C ...+85°C	-40°C ...+85°C	-40°C ...+85°C
Material group	II	II	II	II	II
Material of contact	copper alloy	copper alloy	copper alloy	copper alloy	copper alloy
Contact plating	Au	Au	Au	Au	Au
Insulating material	PA	PA	PA	PA	PA
Material of housing	zinc diecasting nickel plated, brass nickel plated	zinc diecasting nickel plated, brass nickel plated	zinc diecasting nickel plated, brass nickel plated	zinc diecasting nickel plated, brass nickel plated	zinc diecasting nickel plated, brass nickel plated

## Straight cable connectors, shielded

## Female cable connector, shielded,

screw clamp connection, version with shielding ring

Recommended use



A-Code



12pin

Contacts	Cable outlet	Designation	Order No.
3	4-6 mm	M12-F03A-T-D6-SH	163 003 421 2001
	6-8 mm	M12-F03A-T-D8-SH	163 003 421 2002
	8-10 mm	M12-F03A-T-D10-SH	163 003 421 2500
4	4-6 mm	M12-F04A-T-D6-SH	163 004 421 2001
	6-8 mm	M12-F04A-T-D8-SH	163 004 421 2002
	8-10 mm	M12-F04A-T-D10-SH	163 004 421 2502
5	4-6 mm	M12-F05A-T-D6-SH	163 005 421 2001
	6-8 mm	M12-F05A-T-D8-SH	163 005 421 2002
	8-10 mm	M12-F05A-T-D10-SH	163 005 421 2502
8	6-8 mm	M12-F08A-T-D8-SH	163 008 421 2002
	8-10 mm	M12-F08A-T-D10-SH	163 008 421 2500

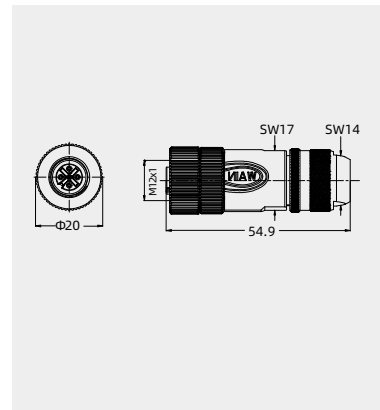

M12-A

## Female cable connector, shielded,

solder, version with shielding ring

Recommended use



A-Code



12pin

Contacts	Cable outlet	Designation	Order No.
3	4-6 mm	M12-FST03A-T-D6-SH	163 003 423 2500
	6-8 mm	M12-FST03A-T-D8-SH	163 003 423 2501
4	4-6 mm	M12-FST04A-T-D6-SH	163 004 423 2500
	6-8 mm	M12-FST04A-T-D8-SH	163 004 423 2002
5	4-6 mm	M12-FST05A-T-D6-SH	163 005 423 2001
	6-8 mm	M12-FST05A-T-D8-SH	163 005 423 2002
8	4-6 mm	M12-FST08A-T-D6-SH	163 008 423 2501
	6-8 mm	M12-FST08A-T-D8-SH	163 008 423 2500
12	6-8 mm	M12-FST12A-T-D8-SH	163 012 423 2003
	8-10 mm	M12-FST12A-T-D10-SH	163 012 421 2500

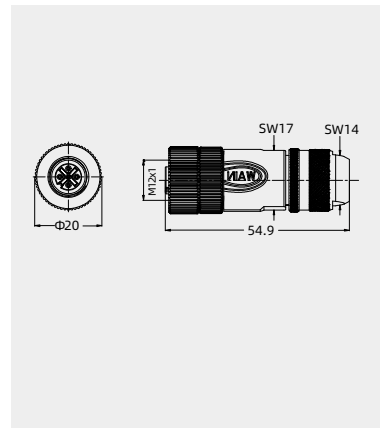

## Hexagonal driver



Description	Designation	Order No.
for 8 pin screw clamp connection	SW-1.27*47	198 001 003 0016

## M12-A Circular Connector

125V 4A

## Technical characteristics

	5-pole
Rated current (40°C)	4A
Rated voltage	125V
Rated impulse voltage	1500V
Pollution degree	3
Overvoltage categorie	II
Contact resistance	≤ 10 mΩ
Connector locking system	screw M12x1
Termination	screw
Wire gauge	max.0.75mm <sup>2</sup> (max.AWG18)
Cable outlet	4-6,6-8mm
Degree of protection	IP67
Mechanical operation	> 100
Limiting temperature	-40°C ...+85°C
Material group	II
Material of contact	copper alloy
Contact plating	Au
Insulating material	PA
Material of housing	zinc diecasting nickel plated, brass nickel plated

## Straight cable connectors, shielded

Female cable connector,

Crimp terminal ,with shielding ring

Order crimp contacts separately

Contacts	Cable outlet	Designation	Order No.
5	6-8 mm	M12-FC05A-T-D8-SH	163 005 420 2501

A-Code



5pin

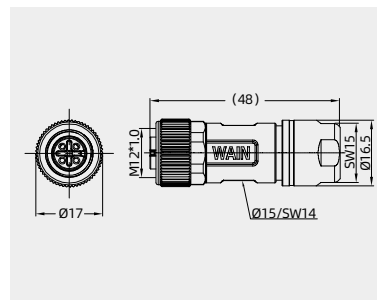

Female cable connector,

Crimp terminal ,with shielding ring

Order crimp contacts separately

Contacts	Cable outlet	Designation	Order No.
5	6-8 mm	M12-FC05A-CCT/R-M16-D8-SH	163 005 720 2001

A-Code



5pin

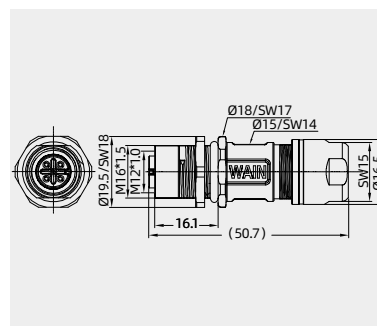

## Crimp contacts

Crimp contacts 5A

Contact resistance ≤ 3mΩ  
gold plated

Wire gauge(mm <sup>2</sup> )	Male	Order No.	Female	Order No.
0.09-0.25	CSGM-0.25	101 014 210 0101	CSGF-0.25	101 014 220 0101
0.13-0.33	CSGM-0.33	101 014 210 0201	CSGF-0.33	101 014 220 0201
0.33-0.52	CSGM-0.52	101 014 210 0501	CSGF-0.52	101 014 220 0501
0.52-0.82	CSGM-0.82	101 014 210 0701	CSGF-0.82	101 014 220 0701

Tools

Crimping tool



Wire gauge	Designation	Order No.
0.09-0.82mm <sup>2</sup>	TL03	198 001 001 0002

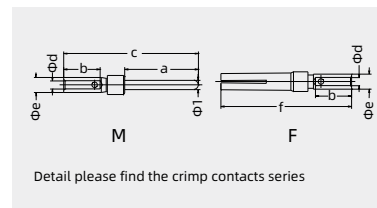

Detail please find the crimp contacts series

Notes: The tools for crimp terminal may influence the product quality and stability. Please select the tools recognized by our company.

## M12-A Circular Connector

60/125/250V 2/4A

## Technical characteristics

	3-pole	4-pole	5-pole	8-pole
Rated current (40°C)	4A	4A	4A	2A
Rated voltage	250V	250V	125V	60V
Rated impulse voltage	2500V	2500V	1500V	800V
Pollution degree	3	3	3	3
Overvoltage categorie	II	II	II	II
Contact resistance	≤ 10 mΩ	≤ 10 mΩ	≤ 10 mΩ	≤ 10 mΩ
Connector locking system	screw M12x1	screw M12x1	screw M12x1	screw M12x1
Termination	screw/solder	screw/solder	screw/solder	solder
Wire gauge	max.0.75mm <sup>2</sup> (max.AWG18)	max.0.75mm <sup>2</sup> (max.AWG18)	max.0.75mm <sup>2</sup> (max.AWG18)	max.0.75mm <sup>2</sup> (max.AWG18)
Cable outlet	4-6,6-8 mm	4-6,6-8 mm	4-6,6-8 mm	4-6,6-8 mm
Degree of protection	IP67	IP67	IP67	IP67
Mechanical operation	> 100	> 100	> 100	> 100
Limiting temperature	-40°C ...+85°C	-40°C ...+85°C	-40°C ...+85°C	-40°C ...+85°C
Material group	II	II	II	II
Material of contact	copper alloy	copper alloy	copper alloy	copper alloy
Contact plating	Au	Au	Au	Au
Insulating material	PA	PA	PA	PA
Material of housing	PA/PBT	PA/PBT	PA/PBT	PA/PBT

## Angled cable connectors

Female cable connector,  
plastic locking system,  
screw clamp connection



## A-Code



Contacts	Cable outlet	Designation	Order No.
3	4-6 mm	M12P-F03A-S-D6	163 003 521 3101
	6-8 mm	M12P-F03A-S-D8	163 003 521 3102
4	4-6 mm	M12P-F04A-S-D6	163 004 521 3101
	6-8 mm	M12P-F04A-S-D8	163 004 521 3102
5	4-6 mm	M12P-F05A-S-D6	163 005 521 3101
	6-8 mm	M12P-F05A-S-D8	163 005 521 3102

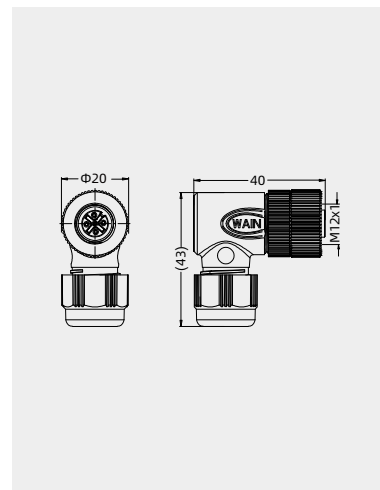

Female cable connector,  
plastic locking system, solder



## A-Code



Contacts	Cable outlet	Designation	Order No.
3	4-6 mm	M12P-FST03A-S-D6	163 003 523 3501
	6-8 mm	M12P-FST03A-S-D8	163 003 523 3502
4	4-6 mm	M12P-FST04A-S-D6	163 004 523 3500
	6-8 mm	M12P-FST04A-S-D8	163 004 523 3501
5	4-6 mm	M12P-FST05A-S-D6	163 005 523 3500
	6-8 mm	M12P-FST05A-S-D8	163 005 523 3501
8	4-6 mm	M12P-FST08A-S-D6	163 008 523 3500
	6-8 mm	M12P-FST08A-S-D8	163 008 523 3501

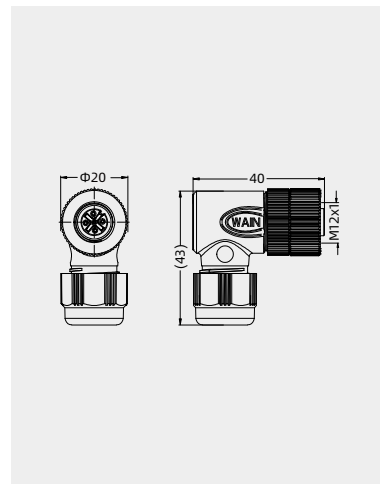

M12-A

## M12-A Circular Connector

60/125/250V 2/4A

## Technical characteristics

	3-pole	4-pole	5-pole	8-pole
Rated current (40°C)	4A	4A	4A	2A
Rated voltage	250V	250V	125V	60V
Rated impulse voltage	2500V	2500V	1500V	800V
Pollution degree	3	3	3	3
Overvoltage categorie	II	II	II	II
Contact resistance	≤ 10 mΩ	≤ 10 mΩ	≤ 10 mΩ	≤ 10 mΩ
Connector locking system	screw M12x1	screw M12x1	screw M12x1	screw M12x1
Termination	screw/solder	screw/solder	screw/solder	solder
Wire gauge	max.0.75mm <sup>2</sup> (max.AWG18)	max.0.75mm <sup>2</sup> (max.AWG18)	max.0.75mm <sup>2</sup> (max.AWG18)	max.0.75mm <sup>2</sup> (max.AWG18)
Cable outlet	4-6,6-8 mm	4-6,6-8 mm	4-6,6-8 mm	4-6,6-8 mm
Degree of protection	IP67	IP67	IP67	IP67
Mechanical operation	> 100	> 100	> 100	> 100
Limiting temperature	-40°C ...+85°C	-40°C ...+85°C	-40°C ...+85°C	-40°C ...+85°C
Material group	II	II	II	II
Material of contact	copper alloy	copper alloy	copper alloy	copper alloy
Contact plating	Au	Au	Au	Au
Insulating material	PA	PA	PA	PA
Material of housing	PA/PBT	PA/PBT	PA/PBT	PA/PBT

## Angled cable connectors

Female angled connector,  
metal locking system,  
screw clamp connection  
**Recommended use**



A-Code



Contacts	Cable outlet	Designation	Order No.
3	4-6 mm	M12-F03A-S-D6	163 003 521 3001
	6-8 mm	M12-F03A-S-D8	163 003 521 3002
4	4-6 mm	M12-F04A-S-D6	163 004 521 3001
	6-8 mm	M12-F04A-S-D8	163 004 521 3002
5	4-6 mm	M12-F05A-S-D6	163 005 521 3001
	6-8 mm	M12-F05A-S-D8	163 005 521 3002

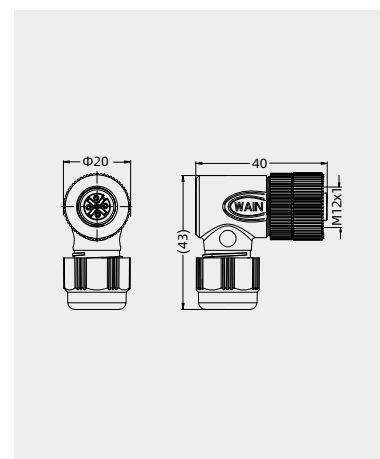

Female angled connector,  
metal locking system, solder  
**Recommended use**



A-Code



Contacts	Cable outlet	Designation	Order No.
3	4-6 mm	M12-FST03A-S-D6	163 003 523 3500
	6-8 mm	M12-FST03A-S-D8	163 003 523 3503
4	4-6 mm	M12-FST04A-S-D6	163 004 523 3502
	6-8 mm	M12-FST04A-S-D8	163 004 523 3503
5	4-6 mm	M12-FST05A-S-D6	163 005 523 3502
	6-8 mm	M12-FST05A-S-D8	163 005 523 3503
8	4-6 mm	M12-FST08A-S-D6	163 008 523 3502
	6-8 mm	M12-FST08A-S-D8	163 008 523 3503

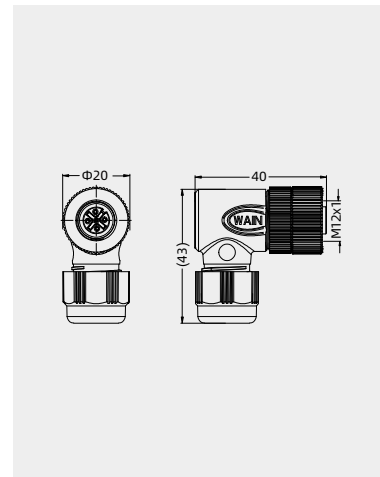



## M12-A Circular Connector

60/125/250V 2/4A

## Technical characteristics

	3-pole	4-pole	5-pole	8-pole
Rated current (40°C)	4A	4A	4A	2A
Rated voltage	250V	250V	125V	60V
Rated impulse voltage	2500V	2500V	1500V	800V
Pollution degree	3	3	3	3
Overvoltage categorie	II	II	II	II
Contact resistance	≤ 10 mΩ	≤ 10 mΩ	≤ 10 mΩ	≤ 10 mΩ
Connector locking system	screw M12x1	screw M12x1	screw M12x1	screw M12x1
Termination	screw/solder	screw/solder	screw/solder	solder
Wire gauge	max.0.75mm <sup>2</sup> (max.AWG18)	max.0.75mm <sup>2</sup> (max.AWG18)	max.0.75mm <sup>2</sup> (max.AWG18)	max.0.75mm <sup>2</sup> (max.AWG18)
Cable outlet	4-6,6-8 mm	4-6,6-8 mm	4-6,6-8 mm	4-6,6-8 mm
Degree of protection	IP67	IP67	IP67	IP67
Mechanical operation	> 100	> 100	> 100	> 100
Limiting temperature	-40°C ...+85°C	-40°C ...+85°C	-40°C ...+85°C	-40°C ...+85°C
Material group	II	II	II	II
Material of contact	copper alloy	copper alloy	copper alloy	copper alloy
Contact plating	Au	Au	Au	Au
Insulating material	PA	PA	PA	PA
Material of housing	PA/PBT	PA/PBT	PA/PBT	PA/PBT

## Angled cable connectors

Female cable connector,  
stainless steel locking system,  
screw clamp connection,



A-Code



Contacts	Cable outlet	Designation	Order No.
3	4-6 mm	M12S-F03A-S-D6	163 003 524 1001
	6-8 mm	M12S-F03A-S-D8	163 003 524 1002
4	4-6 mm	M12S-F04A-S-D6	163 004 521 3201
	6-8 mm	M12S-F04A-S-D8	163 004 521 3202
5	4-6 mm	M12S-F05A-S-D6	163 005 521 3201
	6-8 mm	M12S-F05A-S-D8	163 005 521 3202

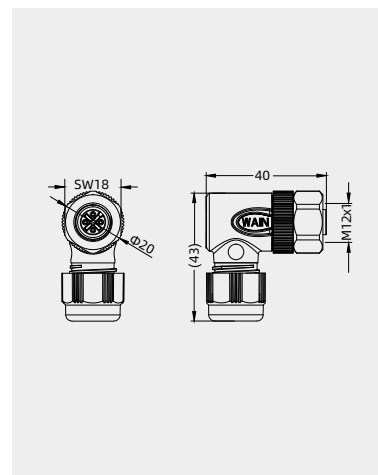

Female cable connector,  
stainless steel locking system,  
solder



A-Code



Contacts	Cable outlet	Designation	Order No.
3	4-6 mm	M12S-FST03A-S-D6	163 003 523 3504
	6-8 mm	M12S-FST03A-S-D8	163 003 523 3505
4	4-6 mm	M12S-FST04A-S-D6	163 004 523 3504
	6-8 mm	M12S-FST04A-S-D8	163 004 523 3505
5	4-6 mm	M12S-FST05A-S-D6	163 005 523 3504
	6-8 mm	M12S-FST05A-S-D8	163 005 523 3505
8	4-6 mm	M12S-FST08A-S-D6	163 008 523 3504
	6-8 mm	M12S-FST08A-S-D8	163 008 523 3505

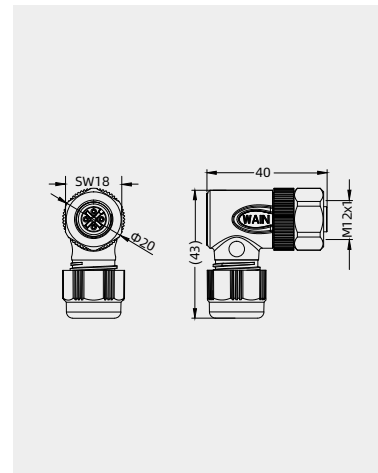

M12-A

## M12-A Circular Connector

60/125/250V 2/4A

## Technical characteristics

	3-pole	4-pole	5-pole	8-pole
Rated current (40°C)	4A	4A	4A	2A
Rated voltage	250V	250V	125V	60V
Rated impulse voltage	2500V	2500V	1500V	800V
Pollution degree	3	3	3	3
Overvoltage categorie	II	II	II	II
Contact resistance	≤ 10 mΩ	≤ 10 mΩ	≤ 10 mΩ	≤ 10 mΩ
Connector locking system	screw M12x1	screw M12x1	screw M12x1	screw M12x1
Termination	screw/solder	screw/solder	screw/solder	solder
Wire gauge	max.0.75mm <sup>2</sup> (max.AWG18)	max.0.75mm <sup>2</sup> (max.AWG18)	max.0.75mm <sup>2</sup> (max.AWG18)	max.0.75mm <sup>2</sup> (max.AWG18)
Cable outlet	4-6,6-8 mm	4-6,6-8 mm	4-6,6-8 mm	4-6,6-8 mm
Degree of protection	IP67	IP67	IP67	IP67
Mechanical operation	> 100	> 100	> 100	> 100
Limiting temperature	-40°C ...+85°C	-40°C ...+85°C	-40°C ...+85°C	-40°C ...+85°C
Material group	III	III	III	III
Material of contact	copper alloy	copper alloy	copper alloy	copper alloy
Contact plating	Au	Au	Au	Au
Insulating material	PA	PA	PA	PA
Material of housing	zinc diecasting nickel plated	zinc diecasting nickel plated	zinc diecasting nickel plated	zinc diecasting nickel plated

## Angled cable connectors, shielded

Female angled connector, shielded,  
screw clamp connection,  
version with shielding ring

Contacts	Cable outlet	Designation	Order No.
3	4-6 mm	M12-F03A-S-D6-SH	163 003 521 2001
	6-8 mm	M12-F03A-S-D8-SH	163 003 521 2002
4	4-6 mm	M12-F04A-S-D6-SH	163 004 521 2001
	6-8 mm	M12-F04A-S-D8-SH	163 004 521 2002
5	4-6 mm	M12-F05A-S-D6-SH	163 005 521 2001
	6-8 mm	M12-F05A-S-D8-SH	163 005 521 2002

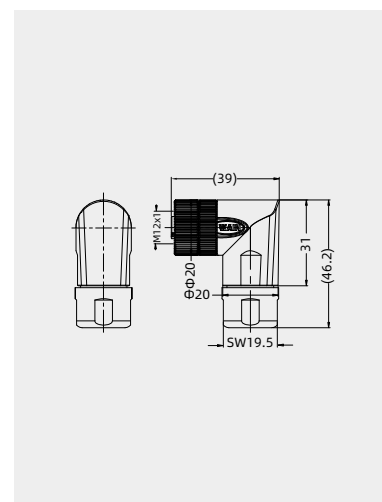

A-Code



Female angled connector, shielded,  
solder, version with shielding ring

Contacts	Cable outlet	Designation	Order No.
3	4-6 mm	M12-FST03A-S-D6-SH	1630035230500
	6-8 mm	M12-FST03A-S-D8-SH	1630035230501
4	4-6 mm	M12-FST04A-S-D6-SH	1630045232500
	6-8 mm	M12-FST04A-S-D8-SH	1630045232501
5	4-6 mm	M12-FST05A-S-D6-SH	1630055232500
	6-8 mm	M12-FST05A-S-D8-SH	1630055232501
8	4-6 mm	M12-FST08A-S-D6-SH	1630085232500
	6-8 mm	M12-FST08A-S-D8-SH	1630085232501

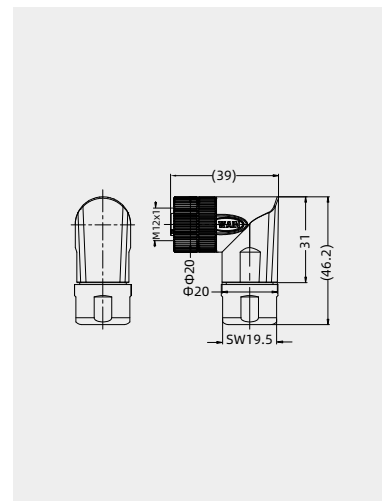

A-Code



## Assembly instruction

### • Assembly instruction

- Strip length male/female cable connector, male/female angled connector, **not shielded**

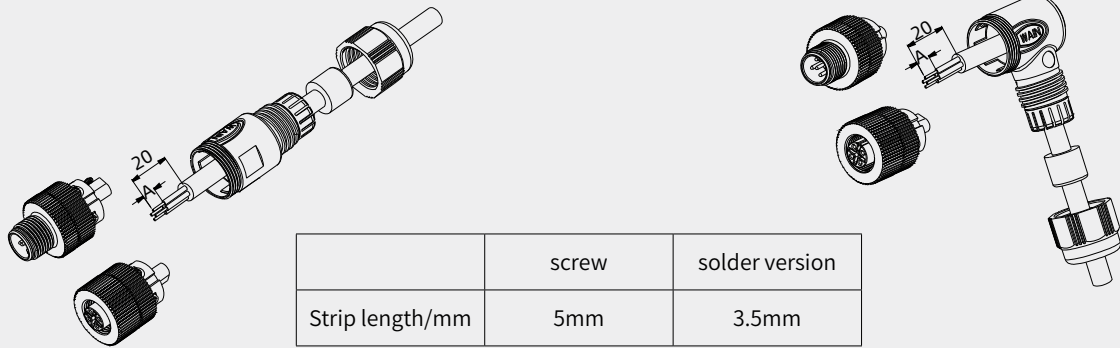

- Strip length male/female cable duo connector, male/female angled duo connector, **not shieldable**

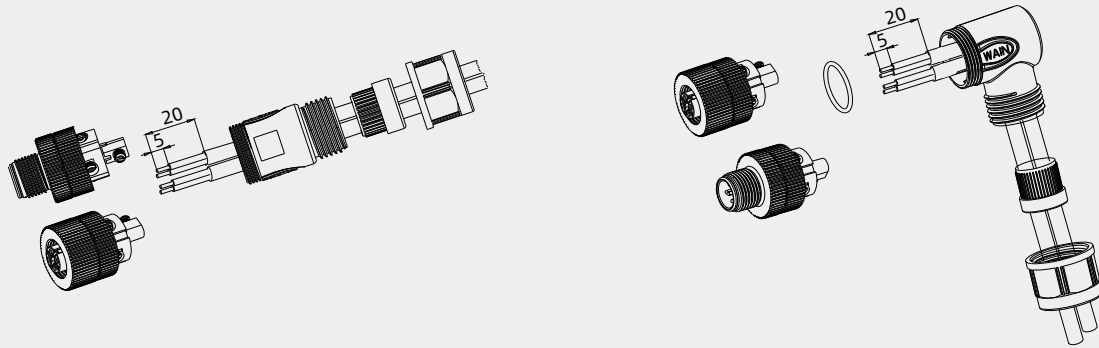

- Strip length male/female cable connector, **with shielding ring**

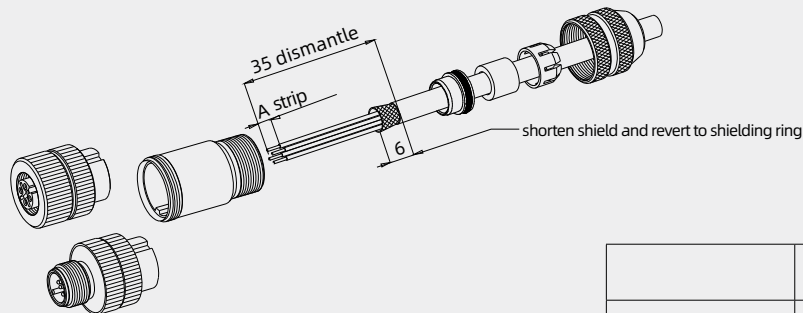

	screw	solder version
Strip length/mm	5mm	3.5mm

Assembly instruction

• Assembly instruction

- Stripping length of male/female angled cable connector, [with shielding ring](#)

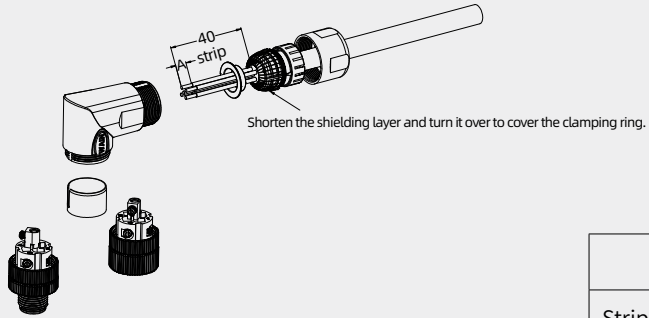

	screw	solder version
Strip length/mm	5mm	3.5mm

Assembly instruction

• Component part drawing

- Straight cable connectors, Angled cable connectors, **not shielded**

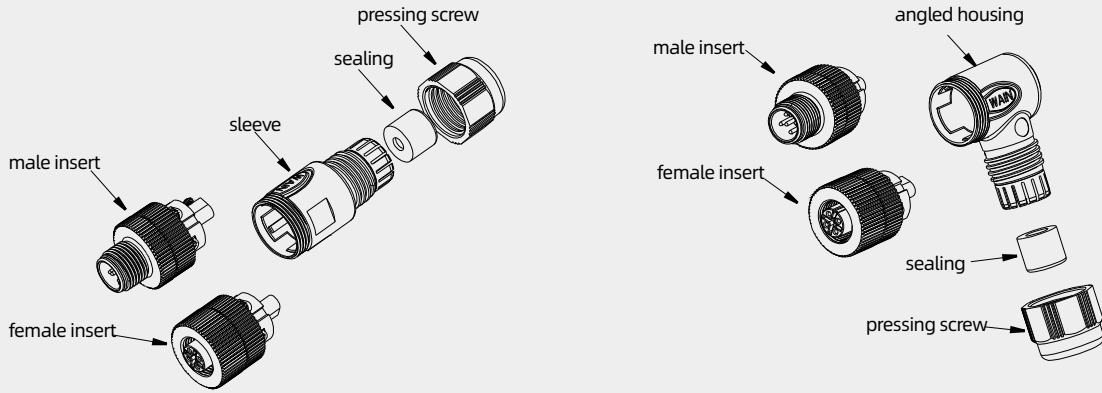

- Straight cable duo connectors, Angled cable duo connectors, **not shielded**

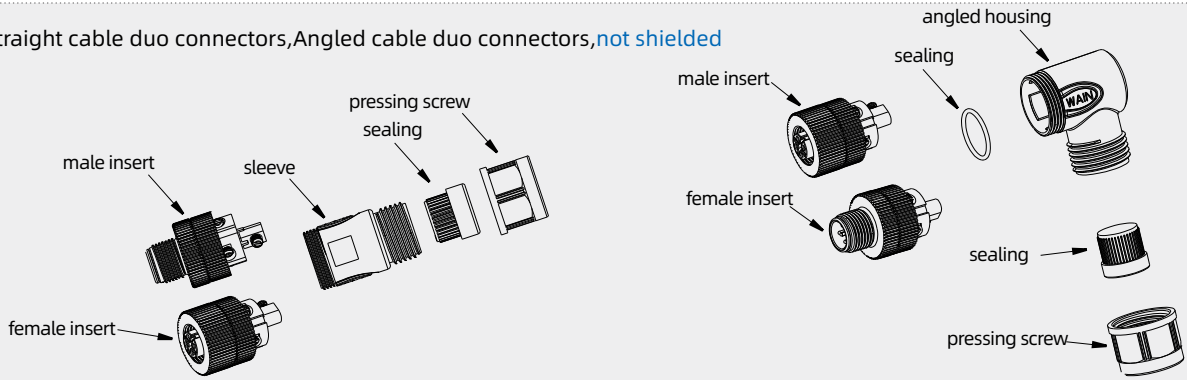

- Straight cable connectors, **with shielding ring**

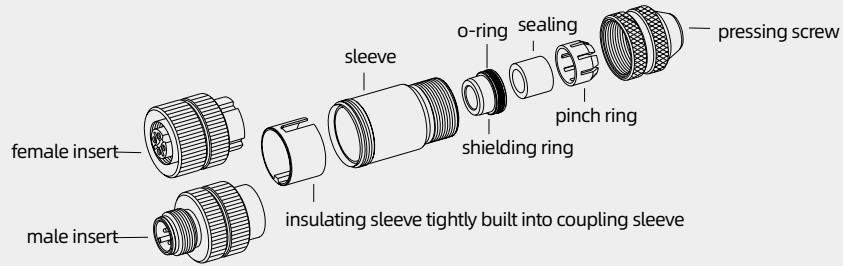

- Angled cable connectors, screw, **with shielding ring**

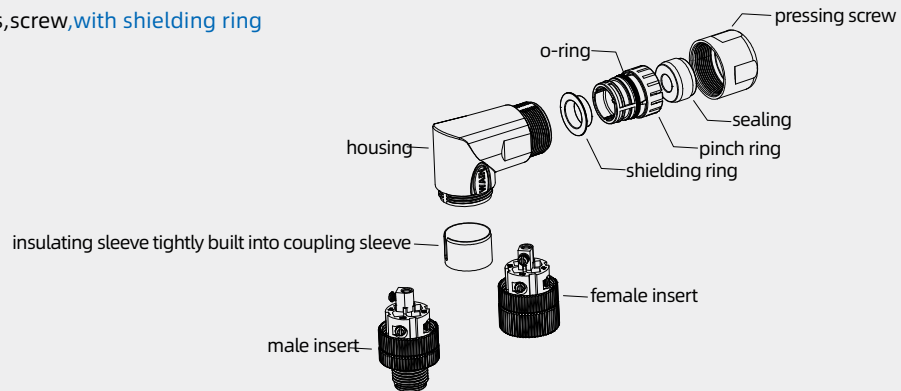

## Rating

- Rating

Attenuation curve according to DIN 47250-6 for straight cable connectors, with shielding ring

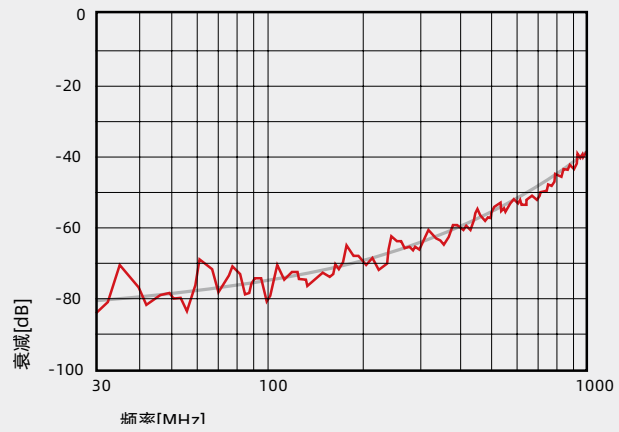

Attenuation curve according to DIN 47250-6 for straight cable connectors, with iris type spring

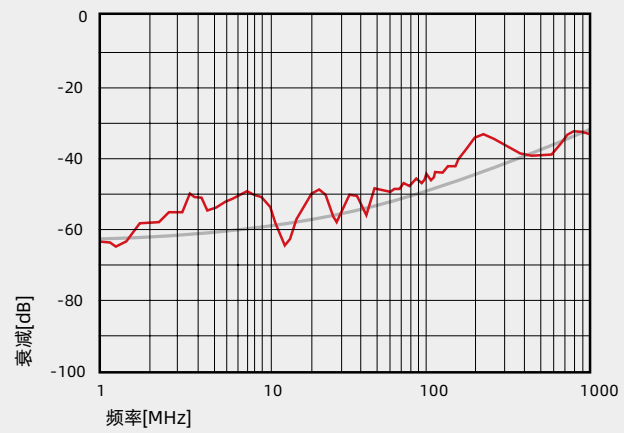

Derating curve according to DIN EN 60512 for POWER cable connectors

- A-coding 4 pole version
- A-coding 5 pole version

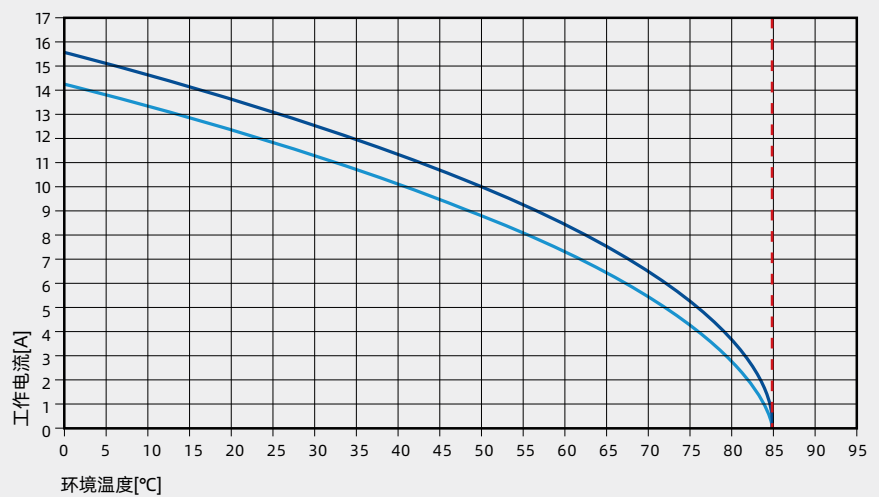

# M12-A Circular Connector

60/125/250V 2/4A

## Technical characteristics

	3-pole	4-pole	5-pole	8-pole	12-pole
Rated current (40°C)	4A	4A	4A	2A	1.5A
Rated voltage	250V	250V	125V	60V	60V
Rated impulse voltage	2500V	2500V	1500V	800V	800V
Pollution degree	3	3	3	3	3
Overvoltage categorie	II	II	II	II	II
Contact resistance	≤ 10 mΩ	≤ 10 mΩ	≤ 10 mΩ	≤ 10 mΩ	≤ 10 mΩ
Connector locking system	screw M12x1	screw M12x1	screw M12x1	screw M12x1	screw M12x1
Termination	crimp, moulded	crimp, moulded	crimp, moulded	crimp, moulded	crimp, moulded
Wire gauge	0.34mm <sup>2</sup> (AWG22)	0.34mm <sup>2</sup> (AWG22)	0.25mm <sup>2</sup> (AWG24)	0.25mm <sup>2</sup> (AWG24)	0.14mm <sup>2</sup> (AWG26)
Cable outlet	-	-	-	-	-
Degree of protection	IP67 shielded	IP67 shielded	IP67 shielded	IP67 shielded	IP67
Mechanical operation	> 100	> 100	> 100	> 100	> 100
Limiting temperature	-25°C ...+85°C	-25°C ...+85°C	-25°C ...+85°C	-25°C ...+85°C	-25°C ...+85°C
Material group	II	II	II	II	II
Material of contact	copper alloy	copper alloy	copper alloy	copper alloy	copper alloy
Contact plating	Au	Au	Au	Au	Au
Insulating material	PA	PA	PA	PA	PA
Material of housing	TPU	TPU	TPU	TPU	TPU

## Straight cable connectors, cable

### Male cable connector moulded, screw

Recommended use



#### A-Code



Contacts	Cable	Cable length	Designation	Order No.
3	3x0.34PVC	1.5 m	M12-M03A-T-1.5-PVC	163 003 401 4001
		5.0 m	M12-M03A-T-5.0-PVC	163 003 401 4002
	3x0.34PUR	1.5 m	M12-M03A-T-1.5-PUR	163 003 401 4041
		5.0 m	M12-M03A-T-5.0-PUR	163 003 401 4042
4	4x0.34PVC	1.5 m	M12-M04A-T-1.5-PVC	163 004 401 4001
		5.0 m	M12-M04A-T-5.0-PVC	163 004 401 4002
	4x0.34PUR	1.5 m	M12-M04A-T-1.5-PUR	163 004 401 4041
		5.0 m	M12-M04A-T-5.0-PUR	163 004 401 4042
5	5x0.25PVC	1.5 m	M12-M05A-T-1.5-PVC	163 005 401 4001
		5.0 m	M12-M05A-T-5.0-PVC	163 005 401 4002
	5x0.25PUR	1.5 m	M12-M05A-T-1.5-PUR	163 005 401 4041
		5.0 m	M12-M05A-T-5.0-PUR	163 005 401 4042
8	8x0.25PUR	1.5 m	M12-M08A-T-1.5-PUR	163 008 401 4041
		5.0 m	M12-M08A-T-5.0-PUR	163 008 401 4042
12	12x0.25PVC	1.5 m	M12-M12A-T-1.5-PVC	163 012 401 4001
		5.0 m	M12-M12A-T-5.0-PVC	163 012 401 4003
	12x0.25PUR	1.5 m	M12-M12A-T-1.5-PUR	163 012 401 4004
		5.0 m	M12-M12A-T-5.0-PUR	163 012 401 4005

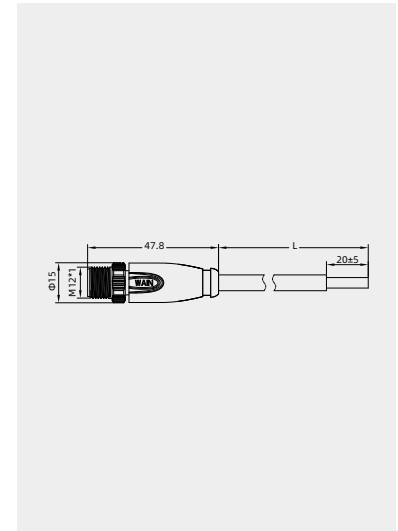

M12-A

### Male cable connector moulded, screw, shielded

Recommended use



#### A-Code

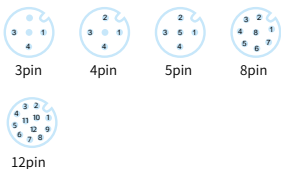

Contacts	Cable	Cable length	Designation	Order No.
3	3x0.34PVC	1.5 m	M12-M03A-T-1.5-PVC-SH	163 003 401 4021
		5.0 m	M12-M03A-T-5.0-PVC-SH	163 003 401 4022
	3x0.34PUR	1.5 m	M12-M03A-T-1.5-PUR-SH	163 003 401 4061
		5.0 m	M12-M03A-T-5.0-PUR-SH	163 003 401 4062
4	4x0.34PVC	1.5 m	M12-M04A-T-1.5-PVC-SH	163 004 401 4021
		5.0 m	M12-M04A-T-5.0-PVC-SH	163 004 401 4022
	4x0.34PUR	1.5 m	M12-M04A-T-1.5-PUR-SH	163 004 401 4061
		5.0 m	M12-M04A-T-5.0-PUR-SH	163 004 401 4062
5	5x0.25PVC	1.5 m	M12-M05A-T-1.5-PVC-SH	163 005 401 4021
		5.0 m	M12-M05A-T-5.0-PVC-SH	163 005 401 4022
	5x0.25PUR	1.5 m	M12-M05A-T-1.5-PUR-SH	163 005 401 4061
		5.0 m	M12-M05A-T-5.0-PUR-SH	163 005 401 4062
8	8x0.25PUR	1.5 m	M12-M08A-T-1.5-PUR-SH	163 008 401 4061
		5.0 m	M12-M08A-T-5.0-PUR-SH	163 008 401 4062
12	12x0.25PVC	1.5 m	M12-M12A-T-1.5-PVC-SH	163 012 401 2001
		5.0 m	M12-M12A-T-5.0-PVC-SH	163 012 401 2002
	12x0.25PUR	1.5 m	M12-M12A-T-1.5-PUR-SH	163 012 401 2003
		5.0 m	M12-M12A-T-5.0-PUR-SH	163 012 401 2004

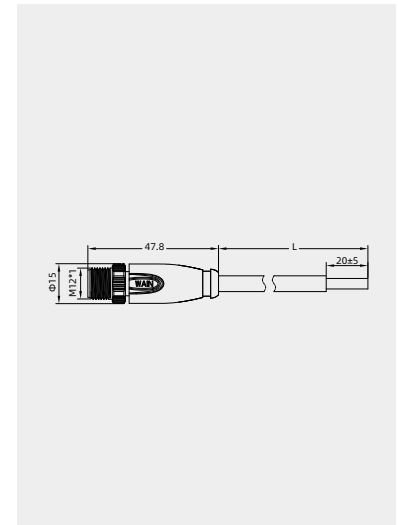

•Further cable length upon request.

## M12-A Circular Connector

125/250V 4A

## Technical characteristics

	3-pole	4-pole	5-pole
Rated current (40°C)	4A	4A	4A
Rated voltage	250V	250V	125V
Rated impulse voltage	2500V	2500V	1500V
Pollution degree	3	3	3
Overvoltage categorie	II	II	II
Contact resistance	≤ 10 mΩ	≤ 10 mΩ	≤ 10 mΩ
Connector locking system	screw M12x1	screw M12x1	screw M12x1
Termination	crimp, moulded	crimp, moulded	crimp, moulded
Wire gauge	0.34mm <sup>2</sup> (AWG22)	0.34mm <sup>2</sup> (AWG22)	0.25mm <sup>2</sup> (AWG24)
Cable outlet	-	-	-
Degree of protection	IP67	IP67	IP67
Mechanical operation	> 100	> 100	> 100
Limiting temperature	-25°C ...+85°C	-25°C ...+85°C	-25°C ...+85°C
Material group	II	II	II
Material of contact	copper alloy	copper alloy	copper alloy
Contact plating	Au	Au	Au
Insulating material	PA	PA	PA
Material of housing	TPU	TPU	TPU

## Straight cable connectors, cable

Male cable connector moulded,  
Stainless steel ring nut, screw



Contacts	Cable	Cable length	Designation	Order No.
3	3x0.34PUR	1.5 m	M12S-M03A-T-1.5-PUR	163 003 401 4241
		5.0 m	M12S-M03A-T-5.0-PUR	163 003 401 4242
4	4x0.34PUR	1.5 m	M12S-M04A-T-1.5-PUR	163 004 401 4241
		5.0 m	M12S-M04A-T-5.0-PUR	163 004 401 4242
5	5x0.25PUR	1.5 m	M12S-M05A-T-1.5-PUR	163 005 401 4241
		5.0 m	M12S-M05A-T-5.0-PUR	163 005 401 4242

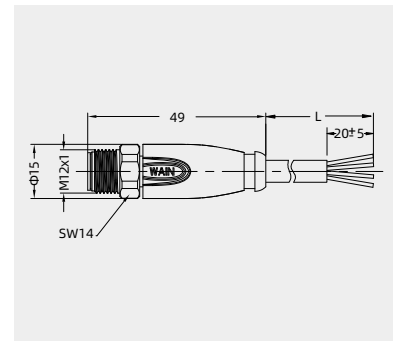

A-Code



3pin

4pin

5pin

•Further cable length upon request.



# M12-A Circular Connector

60/125/250V 2/4A

## Technical characteristics

	3-pole	4-pole	5-pole	8-pole	12-pole
Rated current (40°C)	4A	4A	4A	2A	1.5A
Rated voltage	250V	250V	125V	60V	60V
Rated impulse voltage	2500V	2500V	1500V	800V	800V
Pollution degree	3	3	3	3	3
Overvoltage categorie	II	II	II	II	II
Contact resistance	≤ 10 mΩ	≤ 10 mΩ	≤ 10 mΩ	≤ 10 mΩ	≤ 10 mΩ
Connector locking system	screw M12x1	screw M12x1	screw M12x1	screw M12x1	screw M12x1
Termination	crimp, moulded	crimp, moulded	crimp, moulded	crimp, moulded	crimp, moulded
Wire gauge	0.34mm <sup>2</sup> (AWG22)	0.34mm <sup>2</sup> (AWG22)	0.25mm <sup>2</sup> (AWG24)	0.25mm <sup>2</sup> (AWG24)	0.14mm <sup>2</sup> (AWG26)
Cable outlet	-	-	-	-	-
Degree of protection	IP67 shielded	IP67 shielded	IP67 shielded	IP67 shielded	IP67
Mechanical operation	> 100	> 100	> 100	> 100	> 100
Limiting temperature	-25°C ...+85°C	-25°C ...+85°C	-25°C ...+85°C	-25°C ...+85°C	-25°C ...+85°C
Material group	II	II	II	II	II
Material of contact	copper alloy	copper alloy	copper alloy	copper alloy	copper alloy
Contact plating	Au	Au	Au	Au	Au
Insulating material	PA	PA	PA	PA	PA
Material of housing	TPU	TPU	TPU	TPU	TPU

## Angled cable connectors,cable

### Male cable connector moulded, screw

#### Recommended use



#### A-Code

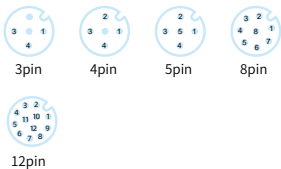

Contacts	Cable	Cable length	Designation	Order No.
3	3x0.34PVC	1.5 m	M12-M03A-S-1.5-PVC	163 003 501 4001
		5.0 m	M12-M03A-S-5.0-PVC	163 003 501 4002
	3x0.34PUR	1.5 m	M12-M03A-S-1.5-PUR	163 003 501 4041
		5.0 m	M12-M03A-S-5.0-PUR	163 003 501 4042
4	4x0.34PVC	1.5 m	M12-M04A-S-1.5-PVC	163 004 501 4001
		5.0 m	M12-M04A-S-5.0-PVC	163 004 501 4015
	4x0.34PUR	1.5 m	M12-M04A-S-1.5-PUR	163 004 501 4041
		5.0 m	M12-M04A-S-5.0-PUR	163 004 501 4042
	5x0.25PVC	1.5 m	M12-M05A-S-1.5-PVC	163 005 501 4001
		5.0 m	M12-M05A-S-5.0-PVC	163 005 501 4002
5x0.25PUR	1.5 m	M12-M05A-S-1.5-PUR	163 005 501 4041	
	5.0 m	M12-M05A-S-5.0-PUR	163 005 501 4042	
8	8x0.25PUR	1.5 m	M12-M08A-S-1.5-PUR	163 008 501 4041
		5.0 m	M12-M08A-S-5.0-PUR	163 008 501 4042
	12x0.25PVC	1.5 m	M12-M12A-S-1.5-PVC	163 012 501 4001
		5.0 m	M12-M12A-S-5.0-PVC	163 012 501 4002
12x0.25PUR	1.5 m	M12-M12A-S-1.5-PUR	163 012 501 4003	
	5.0 m	M12-M12A-S-5.0-PUR	163 012 501 4004	

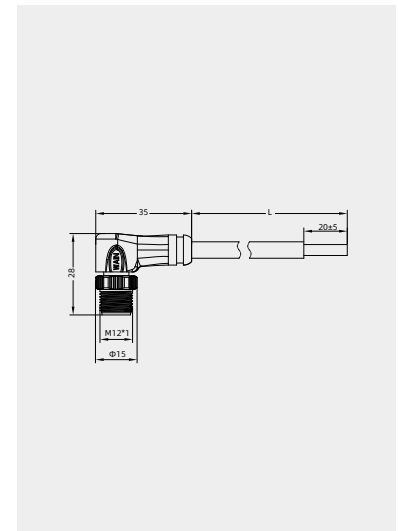

### Male cable connector moulded, screw, shielded

#### Recommended use



#### A-Code

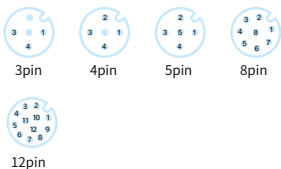

Contacts	Cable	Cable length	Designation	Order No.
3	3x0.34PVC	1.5 m	M12-M03A-S-1.5-PVC-SH	163 003 501 4021
		5.0 m	M12-M03A-S-5.0-PVC-SH	163 003 501 4022
	3x0.34PUR	1.5 m	M12-M03A-S-1.5-PUR-SH	163 003 501 4061
		5.0 m	M12-M03A-S-5.0-PUR-SH	163 003 501 4062
4	4x0.34PVC	1.5 m	M12-M04A-S-1.5-PVC-SH	163 004 501 4021
		5.0 m	M12-M04A-S-5.0-PVC-SH	163 004 501 4022
	4x0.34PUR	1.5 m	M12-M04A-S-1.5-PUR-SH	163 004 501 4061
		5.0 m	M12-M04A-S-5.0-PUR-SH	163 004 501 4062
	5x0.25PVC	1.5 m	M12-M05A-S-1.5-PVC-SH	163 005 501 4021
		5.0 m	M12-M05A-S-5.0-PVC-SH	163 005 501 4022
5x0.25PUR	1.5 m	M12-M05A-S-1.5-PUR-SH	163 005 501 4061	
	5.0 m	M12-M05A-S-5.0-PUR-SH	163 005 501 4062	
8	8x0.25PUR	1.5 m	M12-M08A-S-1.5-PUR-SH	163 008 514 2001
		5.0 m	M12-M08A-S-5.0-PUR-SH	163 008 514 2002
	12x0.25PVC	1.5 m	M12-M12A-S-1.5-PVC-SH	163 012 501 2001
		5.0 m	M12-M12A-S-5.0-PVC-SH	163 012 501 2002
12x0.25PUR	1.5 m	M12-M12A-S-1.5-PUR-SH	163 012 501 2003	
	5.0 m	M12-M12A-S-5.0-PUR-SH	163 012 501 2004	

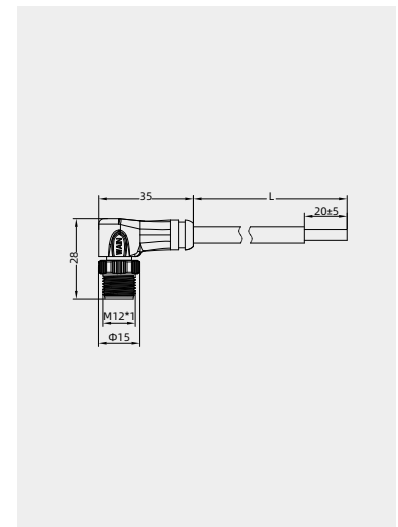

•Further cable length upon request.

M12-A

## M12-A Circular Connector

125/250V 4A

## Technical characteristics

	3-pole	4-pole	5-pole
Rated current (40°C)	4A	4A	4A
Rated voltage	250V	250V	125V
Rated impulse voltage	2500V	2500V	1500V
Pollution degree	3	3	3
Overvoltage categorie	II	II	II
Contact resistance	≤ 10 mΩ	≤ 10 mΩ	≤ 10 mΩ
Connector locking system	screw M12x1	screw M12x1	screw M12x1
Termination	crimp, moulded	crimp, moulded	crimp, moulded
Wire gauge	0.34mm <sup>2</sup> (AWG22)	0.34mm <sup>2</sup> (AWG22)	0.25mm <sup>2</sup> (AWG24)
Cable outlet	-	-	-
Degree of protection	IP67	IP67	IP67
Mechanical operation	> 100	> 100	> 100
Limiting temperature	-25°C ...+85°C	-25°C ...+85°C	-25°C ...+85°C
Material group	II	II	II
Material of contact	copper alloy	copper alloy	copper alloy
Contact plating	Au	Au	Au
Insulating material	PA	PA	PA
Material of housing	TPU	TPU	TPU

## Angled cable connectors, cable

Male angled connector moulded,  
Stainless steel ring nut,screw



A-Code



3pin

4pin

5pin

Contacts	Cable	Cable length	Designation	Order No.
3	3x0.34PUR	1.5 m	M12S-M03A-S-1.5-PUR	163 003 501 4241
		5.0 m	M12S-M03A-S-5.0-PUR	163 003 501 4242
4	4x0.34PUR	1.5 m	M12S-M04A-S-1.5-PUR	163 004 501 4241
		5.0 m	M12S-M04A-S-5.0-PUR	163 004 501 4242
5	5x0.25PUR	1.5 m	M12S-M05A-S-1.5-PUR	163 005 501 4241
		5.0 m	M12S-M05A-S-5.0-PUR	163 005 501 4242

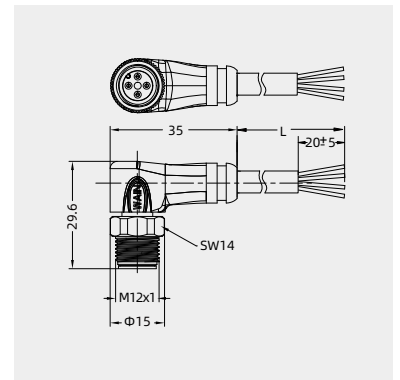

•Further cable length upon request.

# M12-A Circular Connector

60/125/250V 2/4A

## Technical characteristics

	3-pole	4-pole	5-pole	8-pole	12-pole
Rated current (40°C)	4A	4A	4A	2A	1.5A
Rated voltage	250V	250V	125V	60V	60V
Rated impulse voltage	2500V	2500V	1500V	800V	800V
Pollution degree	3	3	3	3	3
Overvoltage categorie	II	II	II	II	II
Contact resistance	≤ 10 mΩ	≤ 10 mΩ	≤ 10 mΩ	≤ 10 mΩ	≤ 10 mΩ
Connector locking system	screw M12x1	screw M12x1	screw M12x1	screw M12x1	screw M12x1
Termination	crimp, moulded	crimp, moulded	crimp, moulded	crimp, moulded	crimp, moulded
Wire gauge	0.34mm <sup>2</sup> (AWG22)	0.34mm <sup>2</sup> (AWG22)	0.25mm <sup>2</sup> AWG24)	0.25mm <sup>2</sup> (AWG24)	0.14mm <sup>2</sup> (AWG26)
Cable outlet	-	-	-	-	-
Degree of protection	IP67 shielded	IP67 shielded	IP67 shielded	IP67 shielded	IP67
Mechanical operation	> 100	> 100	> 100	> 100	> 100
Limiting temperature	-25°C ...+85°C	-25°C ...+85°C	-25°C ...+85°C	-25°C ...+85°C	-25°C ...+85°C
Material group	II	II	II	II	II
Material of contact	copper alloy	copper alloy	copper alloy	copper alloy	copper alloy
Contact plating	Au	Au	Au	Au	Au
Insulating material	PA	PA	PA	PA	PA
Material of housing	TPU	TPU	TPU	TPU	TPU

## Straight cable connectors, cable

### Femalae connector moulded,screw

Recommended use



#### A-Code



Contacts	Cable	Cable length	Designation	Order No.	
3	3x0.34PVC	1.5 m	M12-F03A-T-1.5-PVC	163 003 402 4001	
		5.0 m	M12-F03A-T-5.0-PVC	163 003 402 4002	
	3x0.34PUR	1.5 m	M12-F03A-T-1.5-PUR	163 003 402 4041	
		5.0 m	M12-F03A-T-5.0-PUR	163 003 402 4042	
4	4x0.34PVC	1.5 m	M12-F04A-T-1.5-PVC	163 004 402 4001	
		5.0 m	M12-F04A-T-5.0-PVC	163 004 402 4002	
	4x0.34PUR	1.5 m	M12-F04A-T-1.5-PUR	163 004 402 4041	
		5.0 m	M12-F04A-T-5.0-PUR	163 004 402 4042	
	5	5x0.25PVC	1.5 m	M12-F05A-T-1.5-PVC	163 005 402 4001
			5.0 m	M12-F05A-T-5.0-PVC	163 005 402 4002
5x0.25PUR		1.5 m	M12-F05A-T-1.5-PUR	163 005 402 4041	
		5.0 m	M12-F05A-T-5.0-PUR	163 005 402 4042	
8	8x0.25PUR	1.5 m	M12-F08A-T-1.5-PUR	163 008 402 4041	
		5.0 m	M12-F08A-T-5.0-PUR	163 008 402 4042	
	12	12x0.25PVC	1.5 m	M12-F12A-T-1.5-PVC	163 012 402 4001
			5.0 m	M12-F12A-T-5.0-PVC	163 012 402 4003
12x0.25PUR		1.5 m	M12-F12A-T-1.5-PUR	163 012 402 4004	
		5.0 m	M12-F12A-T-5.0-PUR	163 012 402 4005	

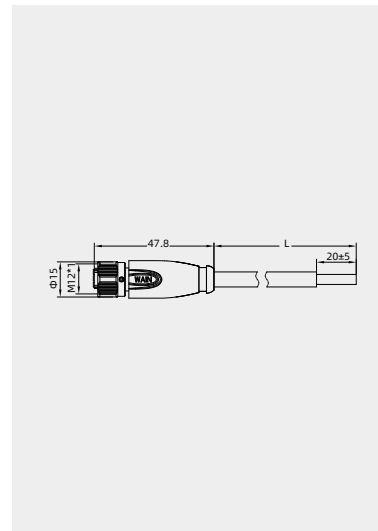

M12-A

### Female connector moulded,screw shielded

Recommended use



#### A-Code



Contacts	Cable	Cable length	Designation	Order No.	
3	3x0.34PVC	1.5 m	M12-F03A-T-1.5-PVC-SH	163 003 402 4021	
		5.0 m	M12-F03A-T-5.0-PVC-SH	163 003 402 4022	
	3x0.34PUR	1.5 m	M12-F03A-T-1.5-PUR-SH	163 003 402 4061	
		5.0 m	M12-F03A-T-5.0-PUR-SH	163 003 402 4062	
4	4x0.34PVC	1.5 m	M12-F04A-T-1.5-PVC-SH	163 004 402 4021	
		5.0 m	M12-F04A-T-5.0-PVC-SH	163 004 402 4022	
	4x0.34PUR	1.5 m	M12-F04A-T-1.5-PUR-SH	163 004 402 4061	
		5.0 m	M12-F04A-T-5.0-PUR-SH	163 004 402 4062	
	5	5x0.25PVC	1.5 m	M12-F05A-T-1.5-PVC-SH	163 005 402 4021
			5.0 m	M12-F05A-T-5.0-PVC-SH	163 005 402 4022
5x0.25PUR		1.5 m	M12-F05A-T-1.5-PUR-SH	163 005 402 4061	
		5.0 m	M12-F05A-T-5.0-PUR-SH	163 005 402 4062	
8	8x0.25PUR	1.5 m	M12-F08A-T-1.5-PUR-SH	163 008 402 4061	
		5.0 m	M12-F08A-T-5.0-PUR-SH	163 008 402 4062	
	12	12x0.25PVC	1.5 m	M12-F12A-T-1.5-PVC-SH	163 012 402 2001
			5.0 m	M12-F12A-T-5.0-PVC-SH	163 012 402 2002
12x0.25PUR		1.5 m	M12-F12A-T-1.5-PUR-SH	163 012 402 2003	
		5.0 m	M12-F12A-T-5.0-PUR-SH	163 012 402 2004	

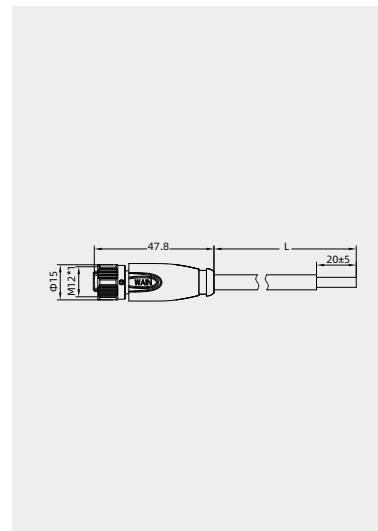

•Further cable length upon request.

## M12-A Circular Connector

125/250V 4A

## Technical characteristics

	3-pole	4-pole	5-pole
Rated current (40°C)	4A	4A	4A
Rated voltage	250V	250V	125V
Rated impulse voltage	2500V	2500V	1500V
Pollution degree	3	3	3
Overvoltage categorie	II	II	II
Contact resistance	≤ 10 mΩ	≤ 10 mΩ	≤ 10 mΩ
Connector locking system	screw M12x1	screw M12x1	screw M12x1
Termination	crimp, moulded	crimp, moulded	crimp, moulded
Wire gauge	0.34mm <sup>2</sup> (AWG22)	0.34mm <sup>2</sup> (AWG22)	0.25mm <sup>2</sup> (AWG24)
Cable outlet	-	-	-
Degree of protection	IP67	IP67	IP67
Mechanical operation	> 100	> 100	> 100
Limiting temperature	-25°C ...+85°C	-25°C ...+85°C	-25°C ...+85°C
Material group	II	II	II
Material of contact	copper alloy	copper alloy	copper alloy
Contact plating	Au	Au	Au
Insulating material	PA	PA	PA
Material of housing	TPU	TPU	TPU

## Straight cable connectors, cable

Female cable connector moulded,  
Stainless steel ring nut,screw



A-Code



3pin

4pin

5pin

Contacts	Cable	Cable length	Designation	Order No.
3	3x0.34PUR	1.5 m	M12S-F03A-T-1.5-PUR	163 003 402 4241
		5.0 m	M12S-F03A-T-5.0-PUR	163 003 402 4242
4	4x0.34PUR	1.5 m	M12S-F04A-T-1.5-PUR	163 004 402 4241
		5.0 m	M12S-F04A-T-5.0-PUR	163 004 402 4242
5	5x0.25PUR	1.5 m	M12S-F05A-T-1.5-PUR	163 005 402 4241
		5.0 m	M12S-F05A-T-5.0-PUR	163 005 402 4242

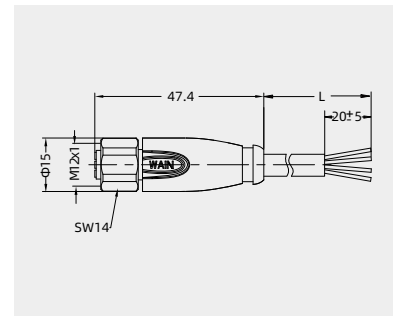

•Further cable length upon request.

# M12-A Circular Connector

60/125/250V 2/4A

## Technical characteristics

	3-pole	4-pole	5-pole	8-pole	12-pole
Rated current (40°C)	4A	4A	4A	2A	1.5A
Rated voltage	250V	250V	125V	60V	60V
Rated impulse voltage	2500V	2500V	1500V	800V	800V
Pollution degree	3	3	3	3	3
Overvoltage categorie	II	II	II	II	II
Contact resistance	≤ 10 mΩ	≤ 10 mΩ	≤ 10 mΩ	≤ 10 mΩ	≤ 10 mΩ
Connector locking system	screw M12x1	screw M12x1	screw M12x1	screw M12x1	screw M12x1
Termination	crimp, moulded	crimp, moulded	crimp, moulded	crimp, moulded	crimp, moulded
Wire gauge	0.34mm <sup>2</sup> (AWG22)	0.34mm <sup>2</sup> (AWG22)	0.25mm <sup>2</sup> (AWG24)	0.25mm <sup>2</sup> (AWG24)	0.14mm <sup>2</sup> (AWG26)
Cable outlet	-	-	-	-	-
Degree of protection	IP67 shielded	IP67 shielded	IP67 shielded	IP67 shielded	IP67
Mechanical operation	> 100	> 100	> 100	> 100	> 100
Limiting temperature	-25°C ...+85°C	-25°C ...+85°C	-25°C ...+85°C	-25°C ...+85°C	-25°C ...+85°C
Material group	II	II	II	II	II
Material of contact	copper alloy	copper alloy	copper alloy	copper alloy	copper alloy
Contact plating	Au	Au	Au	Au	Au
Insulating material	PA	PA	PA	PA	PA
Material of housing	TPU	TPU	TPU	TPU	TPU

## Angled cable connectors, cable

Female angled connector moulded, screw

Recommended use



A-Code



Contacts	Cable	Cable length	Designation	Order No.
3	3x0.34PVC	1.5 m	M12-F03A-S-1.5-PVC	163 003 502 4001
		5.0 m	M12-F03A-S-5.0-PVC	163 003 502 4002
	3x0.34PUR	1.5 m	M12-F03A-S-1.5-PUR	163 003 502 4041
		5.0 m	M12-F03A-S-5.0-PUR	163 003 502 4042
4	4x0.34PVC	1.5 m	M12-F04A-S-1.5-PVC	163 004 502 4001
		5.0 m	M12-F04A-S-5.0-PVC	163 004 502 4002
	4x0.34PUR	1.5 m	M12-F04A-S-1.5-PUR	163 004 502 4041
		5.0 m	M12-F04A-S-5.0-PUR	163 004 502 4042
	5x0.25PVC	1.5 m	M12-F05A-S-1.5-PVC	163 005 502 4001
		5.0 m	M12-F05A-S-5.0-PVC	163 005 502 4002
5x0.25PUR	1.5 m	M12-F05A-S-1.5-PUR	163 005 502 4041	
	5.0 m	M12-F05A-S-5.0-PUR	163 005 502 4042	
8	8x0.25PVC	1.5 m	M12-F08A-S-1.5-PUR	163 008 502 4041
		5.0 m	M12-F08A-S-5.0-PUR	163 008 502 4042
	12x0.25PVC	1.5 m	M12-F12A-S-1.5-PVC	163 012 502 4001
		5.0 m	M12-F12A-S-5.0-PVC	163 012 502 4002
12x0.25PUR	1.5 m	M12-F12A-S-1.5-PUR	163 012 502 4003	
	5.0 m	M12-F12A-S-5.0-PUR	163 012 502 4004	

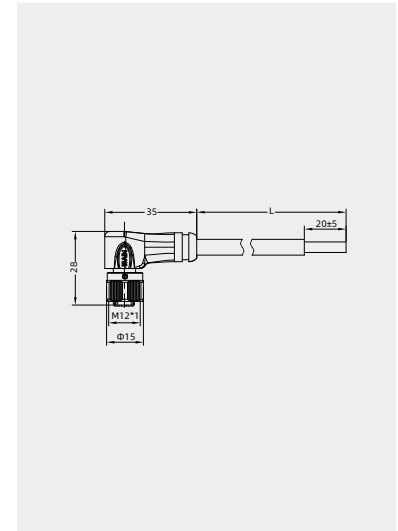

Female angled connector moulded screw, shielded

Recommended use



A-Code

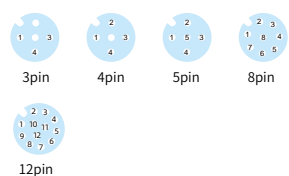

Contacts	Cable	Cable length	Designation	Order No.
3	3x0.34PVC	1.5 m	M12-F03A-S-1.5-PVC-SH	163 003 502 4021
		5.0 m	M12-F03A-S-5.0-PVC-SH	163 003 502 4022
	3x0.34PUR	1.5 m	M12-F03A-S-1.5-PUR-SH	163 003 502 4061
		5.0 m	M12-F03A-S-5.0-PUR-SH	163 003 502 4062
4	4x0.34PVC	1.5 m	M12-F04A-S-1.5-PVC-SH	163 004 502 4021
		5.0 m	M12-F04A-S-5.0-PVC-SH	163 004 502 4022
	4x0.34PUR	1.5 m	M12-F04A-S-1.5-PUR-SH	163 004 502 4061
		5.0 m	M12-F04A-S-5.0-PUR-SH	163 004 502 4062
	5x0.25PVC	1.5 m	M12-F05A-S-1.5-PVC-SH	163 005 502 4021
		5.0 m	M12-F05A-S-5.0-PVC-SH	163 005 502 4022
5x0.25PUR	1.5 m	M12-F05A-S-1.5-PUR-SH	163 005 502 4061	
	5.0 m	M12-F05A-S-5.0-PUR-SH	163 005 502 4062	
8	8x0.25PVC	1.5 m	M12-F08A-S-1.5-PUR-SH	163 008 524 2001
		5.0 m	M12-F08A-S-5.0-PUR-SH	163 008 524 2002
	12x0.25PVC	1.5 m	M12-F12A-S-1.5-PVC-SH	163 012 502 2001
		5.0 m	M12-F12A-S-5.0-PVC-SH	163 012 502 2002
12x0.25PUR	1.5 m	M12-F12A-S-1.5-PUR-SH	163 012 502 2003	
	5.0 m	M12-F12A-S-5.0-PUR-SH	163 012 502 2004	

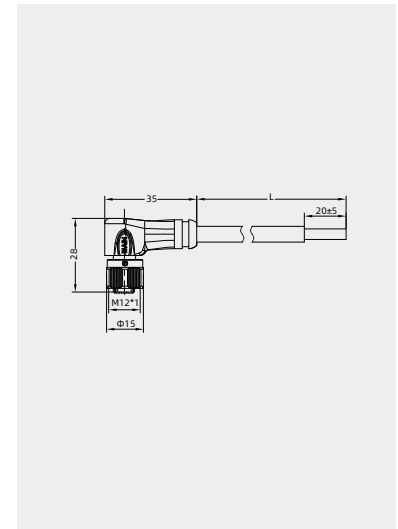

•Further cable length upon request.

## M12-A Circular Connector

125/250V 4A

## Technical characteristics

	3-pole	4-pole	5-pole
Rated current (40°C)	4A	4A	4A
Rated voltage	250V	250V	125V
Rated impulse voltage	2500V	2500V	1500V
Pollution degree	3	3	3
Overvoltage categorie	II	II	II
Contact resistance	≤ 10 mΩ	≤ 10 mΩ	≤ 10 mΩ
Connector locking system	screw M12x1	screw M12x1	screw M12x1
Termination	crimp, moulded	crimp, moulded	crimp, moulded
Wire gauge	0.34mm <sup>2</sup> (AWG22)	0.34mm <sup>2</sup> (AWG22)	0.25mm <sup>2</sup> (AWG24)
Cable outlet	-	-	-
Degree of protection	IP67	IP67	IP67
Mechanical operation	> 100	> 100	> 100
Limiting temperature	-25°C ...+85°C	-25°C ...+85°C	-25°C ...+85°C
Material group	II	II	II
Material of contact	copper alloy	copper alloy	copper alloy
Contact plating	Au	Au	Au
Insulating material	PA	PA	PA
Material of housing	TPU	TPU	TPU

## Angled cable connectors, cable

Female angled connector moulded,  
Stainless steel ring nut, screw



A-Code



3pin

4pin

5pin

Contacts	Cable	Cable length	Designation	Order No.
3	3x0.34PUR	1.5 m	M12S-F03A-S-1.5-PUR	163 003 502 4241
		5.0 m	M12S-F03A-S-5.0-PUR	163 003 502 4242
4	4x0.34PUR	1.5 m	M12S-F04A-S-1.5-PUR	163 004 502 4241
		5.0 m	M12S-F04A-S-5.0-PUR	163 004 502 4242
5	5x0.25PUR	1.5 m	M12S-F05A-S-1.5-PUR	163 005 502 4241
		5.0 m	M12S-F05A-S-5.0-PUR	163 005 502 4242

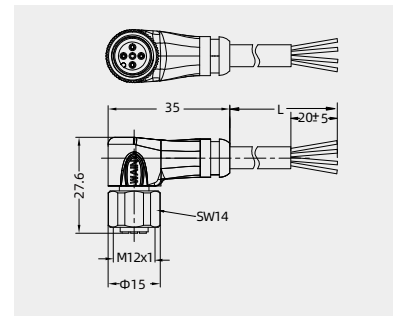

•Further cable length upon request.

# M12-A Circular Connector

36V 4A

## Technical characteristics

	3-pole	4-pole
Rated current (40°C)	4A	4A
Rated voltage	36V	36V
Rated impulse voltage	500V	500V
Pollution degree	3	3
Overvoltage categorie	II	II
Contact resistance	≤ 10 mΩ	≤ 10 mΩ
Connector locking system	screw M12x1	screw M12x1
Termination	crimp, moulded	crimp, moulded
Wire gauge	0.34mm <sup>2</sup> (AWG22)	0.34mm <sup>2</sup> (AWG22)
Cable outlet	-	-
Degree of protection	IP67	IP67
Mechanical operation	> 100	> 100
Limiting temperature	-25°C ...+85°C	-25°C ...+85°C
Material group	II	II
Material of contact	copper alloy	copper alloy
Contact plating	Au	Au
Insulating material	PA	PA
Material of housing	TPU	TPU

## Angled cable connectors ,cable

Female angled connector moulded, with LED PNP normally open



A-Code



3pin

Contacts	Cable	Cable length	Designation	Order No.
3	3x0.34PVC	1.5 m	M12-F03A-S-1.5-PVC-LED	163 003 502 4003
		5.0 m	M12-F03A-S-5.0-PVC-LED	163 003 502 4004
3	3x0.34PUR	1.5 m	M12-F03A-S-1.5-PUR-LED	163 003 502 4043
		5.0 m	M12-F03A-S-5.0-PUR-LED	163 003 502 4044

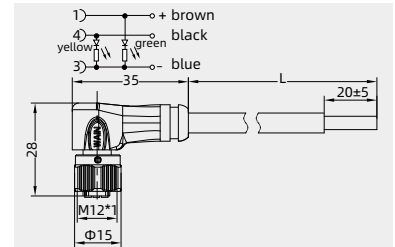

Female angled connector moulded, with LED PNP normally closed/ open,antivalent



A-Code



3pin

Contacts	Cable	Cable length	Designation	Order No.
4	4x0.34PVC	1.5 m	M12-F04A-S-1.5-PVC-LED1	163 004 502 4005
		5.0 m	M12-F04A-S-5.0-PVC-LED1	163 004 502 4006
4	4x0.34PUR	1.5 m	M12-F04A-S-1.5-PUR-LED1	163 004 502 4045
		5.0 m	M12-F04A-S-5.0-PUR-LED1	163 004 502 4046

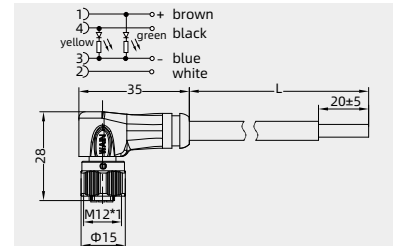

Female angled connector moulded, with LED PNP normally closed/ open



A-Code



4pin

Contacts	Cable	Cable length	Designation	Order No.
3	3x0.34PUR	1.5 m	M12-F03A-S-1.5-PUR-LED2	163 003 502 4047
		5.0 m	M12-F03A-S-5.0-PUR-LED2	163 003 502 4048

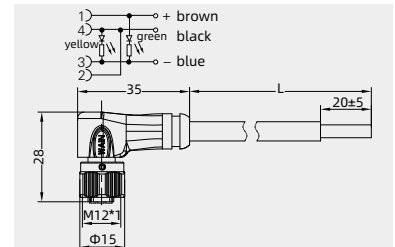

Female angled connector moulded, with LED PNP normally open, stainless steel ring nut



A-Code



3pin

Contacts	Cable	Cable length	Designation	Order No.
3	3x0.34PUR	1.5 m	M12S-F03A-S-1.5-PUR-LED	163 003 502 4243
		5.0 m	M12S-F03A-S-5.0-PUR-LED	163 003 502 4244

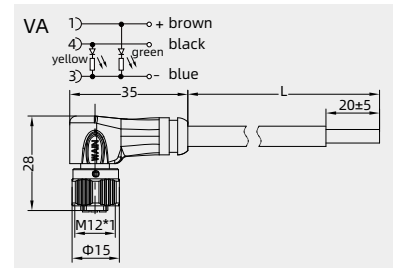

•Further cable length upon request.

## M12-A Circular Connector

60/125/250V 4A

## Technical characteristics

	3-pole	4-pole	5-pole	8-pole	12-pole
Rated current (40°C)	4A	4A	4A	2A	1.5A
Rated voltage	250V	250V	125V	60V	60V
Rated impulse voltage	2500V	2500V	1500V	800V	800V
Pollution degree	3	3	3	3	3
Overvoltage categorie	II	II	II	II	II
Contact resistance	≤ 10 mΩ	≤ 10 mΩ	≤ 10 mΩ	≤ 10 mΩ	≤ 10 mΩ
Connector locking system	screw M12x1	screw M12x1	screw M12x1	screw M12x1	screw M12x1
Termination	crimp, moulded	crimp, moulded	crimp, moulded	crimp, moulded	crimp, moulded
Wire gauge	0.34mm <sup>2</sup> (AWG22)	0.34mm <sup>2</sup> (AWG22)	0.25mm <sup>2</sup> (AWG24)	0.25mm <sup>2</sup> (AWG24)	0.25mm <sup>2</sup> (AWG24)
Cable outlet	-	-	-	-	-
Degree of protection	IP67	IP67	IP67	IP67	IP67
Mechanical operation	> 100	> 100	> 100	> 100	> 100
Limiting temperature	-25°C ...+85°C	-25°C ...+85°C	-25°C ...+85°C	-25°C ...+85°C	-25°C ...+85°C
Material group	II	II	II	II	II
Material of contact	copper alloy	copper alloy	copper alloy	copper alloy	copper alloy
Contact plating	Au	Au	Au	Au	Au
Insulating material	PA	PA	PA	PA	PA
Material of housing	TPU	TPU	TPU	TPU	TPU

## Cable connectors-wire jumper

## Male cable connector

## -female cable connector

Recommended use



Contacts	Cable	Cable length	Designation	Order No.
3	3x0.34PUR	1.5 m	M12-M03A-T/F03A-T-1.5-PUR	163 003 400 4041
		5.0 m	M12-M03A-T/F03A-T-5.0-PUR	163 003 400 4042
4	4x0.34PUR	1.5 m	M12-M04A-T/F04A-T-1.5-PUR	163 004 400 4041
		5.0 m	M12-M04A-T/F04A-T-5.0-PUR	163 004 400 4042
5	5x0.25PUR	1.5 m	M12-M05A-T/F05A-T-1.5-PUR	163 005 400 4041
		5.0 m	M12-M05A-T/F05A-T-5.0-PUR	163 005 400 4042
8	8x0.25PUR	1.5 m	M12-M08A-T/F08A-T-1.5-PUR	163 008 400 4007
		5.0 m	M12-M08A-T/F08A-T-5.0-PUR	163 008 400 4011
12	12x0.25PUR	1.5 m	M12-M12A-T/F12A-T-1.5-PUR	163 012 400 4001
		5.0 m	M12-M12A-T/F12A-T-5.0-PUR	163 012 400 4002

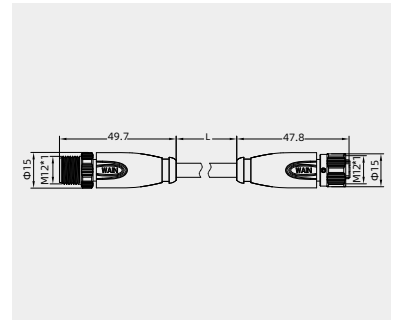

## Male cable connector

## -female angled cable connector

Recommended use



Contacts	Cable	Cable length	Designation	Order No.
3	3x0.34PUR	1.5 m	M12-M03A-T/F03A-S-1.5-PUR	163 003 500 4041
		5.0 m	M12-M03A-T/F03A-S-5.0-PUR	163 003 500 4042
4	4x0.34PUR	1.5 m	M12-M04A-T/F04A-S-1.5-PUR	163 004 500 4041
		5.0 m	M12-M04A-T/F04A-S-5.0-PUR	163 004 500 4042
5	5x0.25PUR	1.5 m	M12-M05A-T/F05A-S-1.5-PUR	163 005 500 4041
		5.0 m	M12-M05A-T/F05A-S-5.0-PUR	163 005 500 4042
8	8x0.25PUR	1.5 m	M12-M08A-T/F08A-S-1.5-PUR	163 008 500 4041
		5.0 m	M12-M08A-T/F08A-S-5.0-PUR	163 008 400 4008
12	12x0.25PUR	1.5 m	M12-M12A-T/F12A-S-1.5-PUR	163 012 400 4003
		5.0 m	M12-M12A-T/F12A-S-5.0-PUR	163 012 500 4001

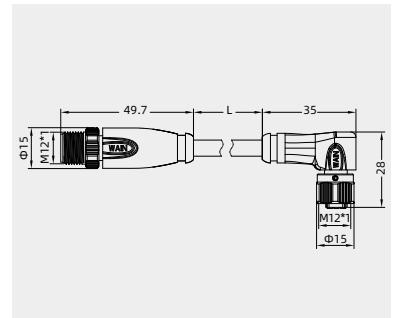

•Other cable lengths can be customized, double-ended connectors, male/female, straight/angled, shielded/unshielded, freely combinable.



# M12-A Circular Connector

60/125/250V 4A

## Technical characteristics

	3-pole	4-pole	5-pole
Rated current (40°C)	4A	4A	4A
Rated voltage	250V	250V	125V
Rated impulse voltage	2500V	2500V	1500V
Pollution degree	3	3	3
Overvoltage categorie	II	II	II
Contact resistance	≤ 10 mΩ	≤ 10 mΩ	≤ 10 mΩ
Connector locking system	screw M12x1	screw M12x1	screw M12x1
Termination	crimp, moulded	crimp, moulded	crimp, moulded
Wire gauge	0.34mm <sup>2</sup> (AWG22)	0.34mm <sup>2</sup> (AWG22)	0.25mm <sup>2</sup> (AWG24)
Cable outlet	-	-	-
Degree of protection	IP67	IP67	IP67
Mechanical operation	> 100	> 100	> 100
Limiting temperature	-25°C ...+85°C	-25°C ...+85°C	-25°C ...+85°C
Material group	II	II	II
Material of contact	copper alloy	copper alloy	copper alloy
Contact plating	Au	Au	Au
Insulating material	PA	PA	PA
Material of housing	TPU	TPU	TPU

## Cable connectors-Y straight head brancher

### Male cable connector

### -female cable connector



Contacts	Cable	Cable length	Designation	Order No.
3	3x0.34PVC	1.5 m	M12Y-M03A/2M12-F03A-T-1.5-PVC	171 302 003 0308
		5.0 m	M12Y-M03A/2M12-F03A-T-5.0-PVC	171 302 003 0309
	3x0.34PUR	1.5 m	M12Y-M03A/2M12-F03A-T-1.5-PUR	171 302 003 0306
		5.0 m	M12Y-M03A/2M12-F03A-T-5.0-PUR	171 302 003 0307
	3x0.34PVC	1.5 m	M12Y-M04A/2M12-F03A-T-1.5-PVC	171 302 003 0302
		5.0 m	M12Y-M04A/2M12-F03A-T-5.0-PVC	171 302 003 0303
3x0.34PUR	1.5 m	M12Y-M04A/2M12-F03A-T-1.5-PUR	171 302 003 0304	
	5.0 m	M12Y-M04A/2M12-F03A-T-5.0-PUR	171 302 003 0305	
4	4x0.34PVC	1.5 m	M12Y-M04A/2M12-F04A-T-1.5-PVC	171 302 004 0307
		5.0 m	M12Y-M04A/2M12-F04A-T-5.0-PVC	171 302 004 0308
	4x0.34PUR	1.5 m	M12Y-M04A/2M12-F04A-T-1.5-PUR	171 302 004 0305
		5.0 m	M12Y-M04A/2M12-F04A-T-5.0-PUR	171 302 004 0306
	5x0.25PVC	1.5 m	M12Y-M05A/2M12-F05A-T-1.5-PVC	171 302 005 0302
		5.0 m	M12Y-M05A/2M12-F05A-T-5.0-PVC	171 302 005 0303
5x0.25PUR	1.5 m	M12Y-M05A/2M12-F05A-T-1.5-PUR	171 302 005 0304	
	5.0 m	M12Y-M05A/2M12-F05A-T-5.0-PUR	171 302 005 0305	

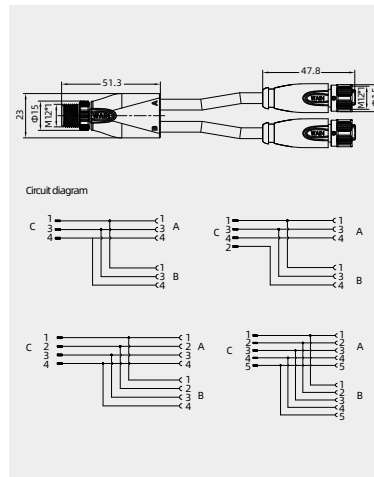

### Male cable connector

### -female angled cable connector



Contacts	Cable	Cable length	Designation	Order No.
3	3x0.34PVC	1.5 m	M12Y-M03A/2M12-F03A-S-1.5-PVC	171 302 003 0318
		5.0 m	M12Y-M03A/2M12-F03A-S-5.0-PVC	171 302 003 0319
	3x0.34PUR	1.5 m	M12Y-M03A/2M12-F03A-S-1.5-PUR	171 302 003 0321
		5.0 m	M12Y-M03A/2M12-F03A-S-5.0-PUR	171 302 003 0322
	3x0.34PVC	1.5 m	M12Y-M04A/2M12-F03A-S-1.5-PVC	171 302 003 0323
		5.0 m	M12Y-M04A/2M12-F03A-S-5.0-PVC	171 302 003 0320
3x0.34PUR	1.5 m	M12Y-M04A/2M12-F03A-S-1.5-PUR	171 302 003 0324	
	5.0 m	M12Y-M04A/2M12-F03A-S-5.0-PUR	171 302 003 0325	
4	4x0.34PVC	1.5 m	M12Y-M04A/2M12-F04A-S-1.5-PVC	171 302 004 0327
		5.0 m	M12Y-M04A/2M12-F04A-S-5.0-PVC	171 302 004 0326
	4x0.34PUR	1.5 m	M12Y-M04A/2M12-F04A-S-1.5-PUR	171 302 004 0328
		5.0 m	M12Y-M04A/2M12-F04A-S-5.0-PUR	171 302 004 0329
	5x0.25PVC	1.5 m	M12Y-M05A/2M12-F05A-S-1.5-PVC	171 302 005 0315
		5.0 m	M12Y-M05A/2M12-F05A-S-5.0-PVC	171 302 005 0314
5x0.25PUR	1.5 m	M12Y-M05A/2M12-F05A-S-1.5-PUR	171 302 005 0316	
	5.0 m	M12Y-M05A/2M12-F05A-S-5.0-PUR	171 302 005 0317	

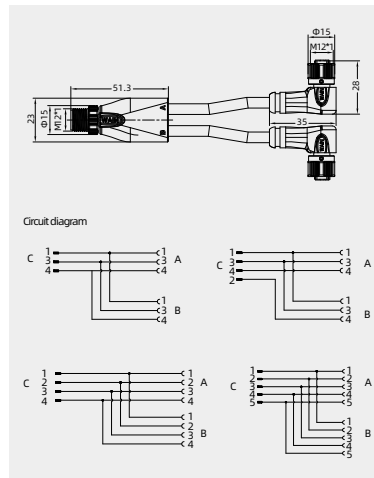

•Other cable lengths can be customized, double-ended connectors, male/female, straight/angled, shielded/unshielded, freely combinable.

## M12-A Circular Connector

60/125/250V 4A

## Technical characteristics

	3-pole	4-pole	5-pole
Rated current (40°C)	4A	4A	4A
Rated voltage	250V	250V	125V
Rated impulse voltage	2500V	2500V	1500V
Pollution degree	3	3	3
Overvoltage categorie	II	II	II
Contact resistance	≤ 10 mΩ	≤ 10 mΩ	≤ 10 mΩ
Connector locking system	screw M12x1	screw M12x1	screw M12x1
Termination	crimp, moulded	crimp, moulded	crimp, moulded
Wire gauge	0.34mm <sup>2</sup> (AWG22)	0.34mm <sup>2</sup> (AWG22)	0.25mm <sup>2</sup> (AWG24)
Cable outlet	-	-	-
Degree of protection	IP67	IP67	IP67
Mechanical operation	> 100	> 100	> 100
Limiting temperature	-25°C ...+85°C	-25°C ...+85°C	-25°C ...+85°C
Material group	II	II	II
Material of contact	copper alloy	copper alloy	copper alloy
Contact plating	Au	Au	Au
Insulating material	PA	PA	PA
Material of housing	TPU	TPU	TPU

## Cable connectors-Y straight head brancher

## Male angled cable connector

## -female cable connector



Contacts	Cable	Cable length	Designation	Order No.
3	3x0.34PVC	1.5 m	M12Y-M03A-S/2M12-F03A-T-1.5-PVC	171 302 003 0310
		5.0 m	M12Y-M03A-S/2M12-F03A-T-5.0-PVC	171 302 003 0312
	3x0.34PUR	1.5 m	M12Y-M03A-S/2M12-F03A-T-1.5-PUR	171 302 003 0311
		5.0 m	M12Y-M03A-S/2M12-F03A-T-5.0-PUR	171 302 003 0313
	3x0.34PVC	1.5 m	M12Y-M04A-S/2M12-F03A-T-1.5-PVC	171 302 004 0309
		5.0 m	M12Y-M04A-S/2M12-F03A-T-5.0-PVC	171 302 004 0311
4	3x0.34PUR	1.5 m	M12Y-M04A-S/2M12-F03A-T-1.5-PUR	171 302 004 0310
		5.0 m	M12Y-M04A-S/2M12-F03A-T-5.0-PUR	171 302 004 0312
	4x0.34PVC	1.5 m	M12Y-M04A-S/2M12-F04A-T-1.5-PVC	171 302 004 0313
		5.0 m	M12Y-M04A-S/2M12-F04A-T-5.0-PVC	171 302 004 0315
	4x0.34PUR	1.5 m	M12Y-M04A-S/2M12-F04A-T-1.5-PUR	171 302 004 0314
		5.0 m	M12Y-M04A-S/2M12-F04A-T-5.0-PUR	171 302 004 0316
5	5x0.25PVC	1.5 m	M12Y-M05A-S/2M12-F05A-T-1.5-PVC	171 302 005 0306
		5.0 m	M12Y-M05A-S/2M12-F05A-T-5.0-PVC	171 302 005 0308
	5x0.25PUR	1.5 m	M12Y-M05A-S/2M12-F05A-T-1.5-PUR	171 302 005 0307
		5.0 m	M12Y-M05A-S/2M12-F05A-T-5.0-PUR	171 302 005 0309

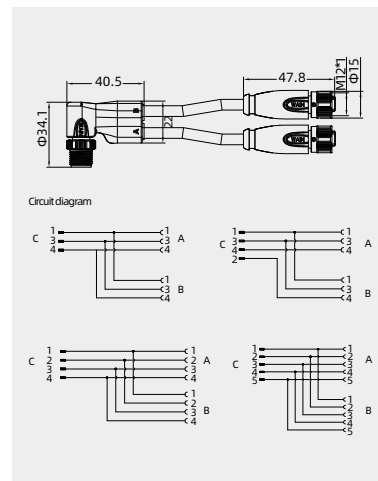

## Male angled cable connector

## -female angled cable connector



Contacts	Cable	Cable length	Designation	Order No.
3	3x0.34PVC	1.5 m	M12Y-M03A-S/2M12-F03A-S-1.5-PVC	171 302 003 0314
		5.0 m	M12Y-M03A-S/2M12-F03A-S-5.0-PVC	171 302 003 0316
	3x0.34PUR	1.5 m	M12Y-M03A-S/2M12-F03A-S-1.5-PUR	171 302 003 0315
		5.0 m	M12Y-M03A-S/2M12-F03A-S-5.0-PUR	171 302 003 0317
	3x0.34PVC	1.5 m	M12Y-M04A-S/2M12-F03A-S-1.5-PVC	171 302 004 0318
		5.0 m	M12Y-M04A-S/2M12-F03A-S-5.0-PVC	171 302 004 0320
4	3x0.34PUR	1.5 m	M12Y-M04A-S/2M12-F03A-S-1.5-PUR	171 302 004 0319
		5.0 m	M12Y-M04A-S/2M12-F03A-S-5.0-PUR	171 302 004 0321
	4x0.34PVC	1.5 m	M12Y-M04A-S/2M12-F04A-S-1.5-PVC	171 302 004 0322
		5.0 m	M12Y-M04A-S/2M12-F04A-S-5.0-PVC	171 302 004 0324
	4x0.34PUR	1.5 m	M12Y-M04A-S/2M12-F04A-S-1.5-PUR	171 302 004 0323
		5.0 m	M12Y-M04A-S/2M12-F04A-S-5.0-PUR	171 302 004 0325
5	5x0.25PVC	1.5 m	M12Y-M05A-S/2M12-F05A-S-1.5-PVC	171 302 005 0310
		5.0 m	M12Y-M05A-S/2M12-F05A-S-5.0-PVC	171 302 005 0312
	5x0.25PUR	1.5 m	M12Y-M05A-S/2M12-F05A-S-1.5-PUR	171 302 005 0311
		5.0 m	M12Y-M05A-S/2M12-F05A-S-5.0-PUR	171 302 005 0313

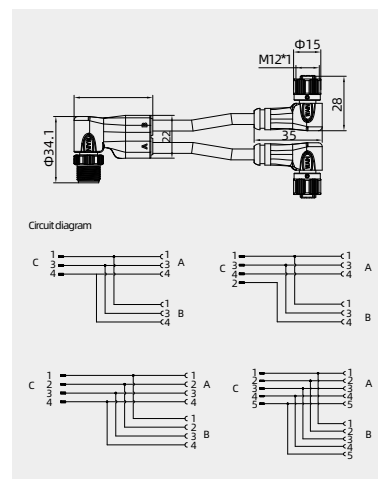

•Other cable lengths can be customized, double-ended connectors, male/female, straight/angled, shielded/unshielded, freely combinable.

## CableTechnical characteristics

## Standard cable

	3-pole	4-pole	5-pole	12-pole
Wire gauge mm <sup>2 1)</sup>	3x0.34mm <sup>2</sup>	4x0.34mm <sup>2</sup>	5x0.25mm <sup>2</sup>	12x0.25mm <sup>2</sup>
Material jacket	PVC / TPU	PVC / TPU	PVC / TPU	TPU
Insulation wire	PVC	PVC	PVC	PVC
Design of wire (mm)	42x0.1	7x0.25 / 42x0.1	14x0.16 / 32x0.1	14x0.25
Cable jacket (mm)	5.2	5.6	5.6	7
Resistance of wire	58Ω/Km / 55Ω/Km	79.9Ω/Km / 55Ω/Km	79.9Ω/Km / 55Ω/Km	73Ω/Km
Temperature range (cable in move)	-5°C ...+70°C	-5°C ...+70°C	-5°C ...+70°C	-5°C ...+70°C
Temperature range (cable not in move)	-25°C ...+70°C	-25°C ...+70°C	-25°C ...+70°C	-25°C ...+70°C
Bending radius (cable in move)	- / 10xD	- / 10xD	- / 10xD	15xD
Bending radius (cable not in move)	- / 5xD	- / 5xD	- / 5xD	8xD
Approval	-	-	-	-

## Shielded cable

	3-pole	4-pole	5-pole	8-pole
Wire gauge mm <sup>2 1)</sup>	3x0.34mm <sup>2</sup>	4x0.34mm <sup>2</sup>	5x0.25mm <sup>2</sup>	8x0.25mm <sup>2</sup>
Material jacket	PVC / TPU	PVC / TPU	PVC	TPU
Insulation wire	PVC	PVC	PVC	PVC
Design of wire (mm)	7x0.25	7x0.25	14x0.16	19x0.127
Cable jacket (mm)	5	5	5.3	6
Resistance of wire	53Ω/Km	53Ω/Km	75.5Ω/Km	73Ω/Km
Temperature range (cable in move)	-5°C ...+70°C	-5°C ...+70°C	-5°C ...+70°C	-5°C ...+70°C
Temperature range (cable not in move)	-25°C ...+70°C	-25°C ...+70°C	-25°C ...+70°C	-25°C ...+70°C
Bending radius (cable in move)	10xD	10xD	20xD	20xD
Bending radius (cable not in move)	5xD	5xD	10xD	10xD
Approval	-	-	-	-
Cover screen grid	80% / 90%	80% / 90%	90%	85%



## M12-A Circular Connector

60/125/250V 2/4A

## Technical characteristics

	4-pole	5-pole	8-pole
Rated current (40°C)	4A	4A	2A
Rated voltage	250V	125V	60V
Rated impulse voltage	2500V	1500V	800V
Pollution degree	3	3	3
Overvoltage categorie	II	II	II
Contact resistance	≤ 10 mΩ	≤ 10 mΩ	≤ 10 mΩ
Connector locking system	screw M12x1	screw M12x1	screw M12x1
Termination	single-strand wires	single-strand wires	single-strand wires
Wire gauge	max.0.75mm <sup>2</sup> (max.AWG18)	max.0.75mm <sup>2</sup> (max.AWG18)	max.0.34mm <sup>2</sup> (max.AWG22)
Cable outlet	-	-	-
Degree of protection	IP67	IP67	IP67
Mechanical operation	> 100	> 100	> 100
Limiting temperature	-40°C ...+85°C	-40°C ...+85°C	-40°C ...+85°C
Material group	II	II	II
Material of contact	copper alloy	copper alloy	copper alloy
Contact plating	Au	Au	Au
Insulating material	PA	PA	PA
Material of housing	zinc diecasting nickel plated	zinc diecasting nickel plated	zinc diecasting nickel plated

## Socket

Male panel mount connector,  
solder

Recommended use



A-Code



4pin



5pin



8pin

Contacts	screw	Designation	Order No.
4	PG9	M12-M04A-BK-PG9-C	163 004 313 1001
	M16x1.5	M12-M04A-BK-M16-C	163 004 313 1021
5	PG9	M12-M05A-BK-PG9-C	163 005 313 1001
	M16x1.5	M12-M05A-BK-M16-C	163 005 313 1021
8	PG9	M12-M08A-BK-PG9-C	163 008 313 1001
	M16x1.5	M12-M08A-BK-M16-C	163 008 313 1021
12	PG9	M12-M12A-BK-PG9-C	163 012 313 1500
	M16x1.5	M12-M12A-BK-M16-C	163 012 313 1501

Customized cable length upon request

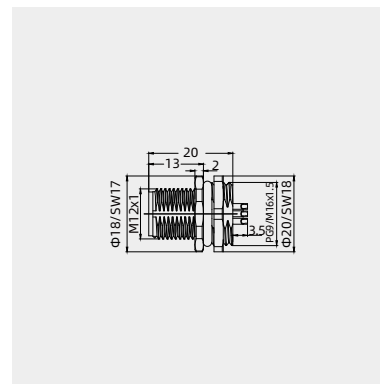

M12-A

## M12-A Circular Connector

60/125/250V 2/4A

## Technical characteristics

	4-pole	5-pole	8-pole	12-pole
Rated current (40°C)	4A	4A	2A	1.5A
Rated voltage	250V	125V	60V	60V
Rated impulse voltage	2500V	1500V	800V	800V
Pollution degree	3	3	3	3
Overvoltage categorie	II	II	II	II
Contact resistance	≤ 10 mΩ	≤ 10 mΩ	≤ 10 mΩ	≤ 10 mΩ
Connector locking system	screw M12x1	screw M12x1	screw M12x1	screw M12x1
Termination	single-strand wires	single-strand wires	single-strand wires	single-strand wires
Wire gauge	max.0.75mm <sup>2</sup> (max.AWG18)	max.0.75mm <sup>2</sup> (max.AWG18)	max.0.34mm <sup>2</sup> (max.AWG22)	max.0.14mm <sup>2</sup> (max.AWG26)
Cable outlet	-	-	-	-
Degree of protection	IP67	IP67	IP67	IP67
Mechanical operation	> 100	> 100	> 100	> 100
Limiting temperature	-40°C ...+85°C	-40°C ...+85°C	-40°C ...+85°C	-40°C ...+85°C
Material group	II	II	II	II
Material of contact	copper alloy	copper alloy	copper alloy	copper alloy
Contact plating	Au	Au	Au	Au
Insulating material	PA	PA	PA	PA
Material of housing	zinc diecasting nickel plated	zinc diecasting nickel plated	zinc diecasting nickel plated	zinc diecasting nickel plated

## Socket

Male panel mount connector  
with single wires, 0,25mm<sup>2</sup>  
length 0.2m  
front fastened,



Contacts	screw	Designation	Order No.
4	PG9	M12-M04A-BKR-PG9-W0.25	163 004 301 4011
	M16x1.5	M12-M04A-BKR-M16-W0.25	163 004 301 4031
5	PG9	M12-M05A-BKR-PG9-W0.25	163 005 301 4011
	M16x1.5	M12-M05A-BKR-M16-W0.25	163 005 301 4031
8	PG9	M12-M08A-BKR-PG9-W0.25	163 008 301 4011
	M16x1.5	M12-M08A-BKR-M16-W0.25	163 008 301 4031
12	PG9	M12-M12A-BKR-PG9-W0.14	163 012 301 4011
	M16x1.5	M12-M12A-BKR-M16-W0.14	163 012 301 4012

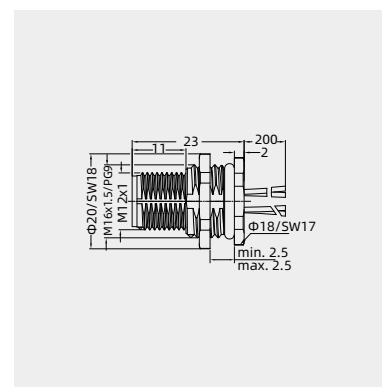

## A-Code



Customized cable length upon request



## M12-A Circular Connector

60/125/250V 2/4A

## Technical characteristics

	4-pole	5-pole	8-pole	12-pole
Rated current (40°C)	4A	4A	2A	1.5A
Rated voltage	250V	125V	60V	60V
Rated impulse voltage	2500V	1500V	800V	800V
Pollution degree	3	3	3	3
Overvoltage categorie	II	II	II	II
Contact resistance	≤ 10 mΩ	≤ 10 mΩ	≤ 10 mΩ	≤ 10 mΩ
Connector locking system	screw	screw	screw	screw
Termination	solder,single-strand wires	solder,single-strand wires	solder,single-strand wires	solder,single-strand wires
Wire gauge	max.0.75mm <sup>2</sup> (max.AWG18)	max.0.75mm <sup>2</sup> (max.AWG18)	max.0.34mm <sup>2</sup> (max.AWG22)	max.0.14mm <sup>2</sup> (max.AWG26)
Cable outlet	-	-	-	-
Degree of protection	IP67	IP67	IP67	IP67
Mechanical operation	> 100	> 100	> 100	> 100
Limiting temperature	-40°C ...+85°C	-40°C ...+85°C	-40°C ...+85°C	-40°C ...+85°C
Material group	II	II	II	II
Material of contact	copper alloy	copper alloy	copper alloy	copper alloy
Contact plating	Au	Au	Au	Au
Insulating material	PA	PA	PA	PA
Material of housing	zinc diecasting nickel plated	zinc diecasting nickel plated	zinc diecasting nickel plated	zinc diecasting nickel plated

## Socket

Female panel mount connector  
with single wires, /0.25mm<sup>2</sup>/length  
0.2m



## A-Code



Contacts	screw	Designation	Order No.
4	PG9	M12-F04A-BK-PG9-W0.25	163 004 302 4001
	M16x1.5	M12-F04A-BK-M16-W0.25	163 004 302 4021
5	PG9	M12-F05A-BK-PG9-W0.25	163 005 302 4001
	M16x1.5	M12-F05A-BK-M16-W0.25	163 005 302 4021
8	PG9	M12-F08A-BK-PG9-W0.25	163 008 302 4001
	M16x1.5	M12-F08A-BK-M16-W0.25	163 008 302 4021
12	PG9	M12-F12A-BK-PG9-W0.14	163 012 302 4001
	M16x1.5	M12-F12A-BK-M16-W0.14	163 012 302 4002

Customized cable length upon request

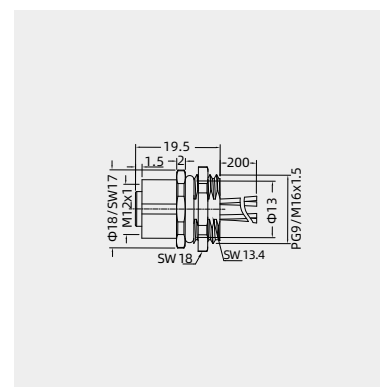

Female panel mount connector, solder  
PG9/M16x1.5



## A-Code

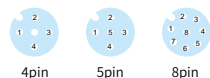

Contacts	screw	Designation	Order No.
4	PG9	M12-F04A-BK-PG9-C	163 004 323 1001
	M16x1.5	M12-F04A-BK-M16-C	163 004 323 1021
5	PG9	M12-F05A-BK-PG9-C	163 005 323 1001
	M16x1.5	M12-F05A-BK-M16-C	163 005 323 1021
8	PG9	M12-F08A-BK-PG9-C	163 008 324 1002
	M16x1.5	M12-F08A-BK-M16-C	163 008 302 1011
12	PG9	M12-F12A-BK-PG9-C	163 012 323 1500
	M16x1.5	M12-F12A-BK-M16-C	163 012 323 1501

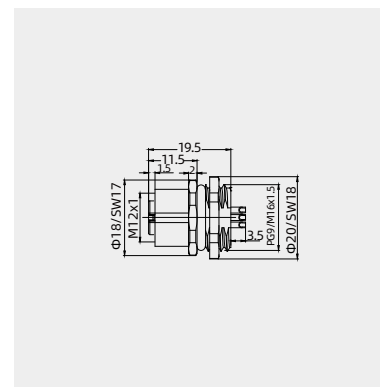



## M12-A Circular Connector

60/125/250V 2/4A

## Technical characteristics

	4-pole	5-pole	8-pole	12-pole
Rated current (40°C)	4A	4A	2A	1.5A
Rated voltage	250V	125V	60V	60V
Rated impulse voltage	2500V	1500V	800V	800V
Pollution degree	3	3	3	3
Overvoltage categorie	II	II	II	II
Contact resistance	≤ 10 mΩ	≤ 10 mΩ	≤ 10 mΩ	≤ 10 mΩ
Connector locking system	screw	screw	screw	screw
Termination	single-strand wires	single-strand wires	single-strand wires	single-strand wires
Wire gauge	max.0.75mm <sup>2</sup> (max.AWG18)	max.0.75mm <sup>2</sup> (max.AWG18)	max.0.34mm <sup>2</sup> (max.AWG22)	max.0.14mm <sup>2</sup> (max.AWG26)
Cable outlet	-	-	-	-
Degree of protection	IP67	IP67	IP67	IP67
Mechanical operation	> 100	> 100	> 100	> 100
Limiting temperature	-40°C ...+85°C	-40°C ...+85°C	-40°C ...+85°C	-40°C ...+85°C
Material group	II	II	II	II
Material of contact	copper alloy	copper alloy	copper alloy	copper alloy
Contact plating	Au	Au	Au	Au
Insulating material	PA	PA	PA	PA
Material of housing	zinc diecasting nickel plated	zinc diecasting nickel plated	zinc diecasting nickel plated	zinc diecasting nickel plated

## Socket

Female panel mount connector,  
front fastened, with single wires,  
0.25mm<sup>2</sup>/length 0.2m



## A-Code



4pin

5pin

8pin

12pin

Contacts	screw	Designation	Order No.
4	PG9	M12-F04A-BKR-PG9-W0.25	163 004 302 4011
	M16x1.5	M12-F04A-BKR-M16-W0.25	163 004 302 4031
5	PG9	M12-F05A-BKR-PG9-W0.25	163 005 302 4011
	M16x1.5	M12-F05A-BKR-M16-W0.25	163 005 302 4031
8	PG9	M12-F08A-BKR-PG9-W0.25	163 008 302 4011
	M16x1.5	M12-F08A-BKR-M16-W0.25	163 008 624 1002
12	PG9	M12-F12A-BKR-PG9-W0.14	163 012 302 4003
	M16x1.5	M12-F12A-BKR-M16-W0.14	163 012 302 4004

Customized cable length upon request

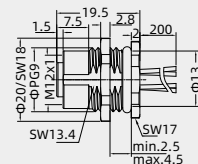

M12-A

# M12-A Circular Connector

125/250V 4A

## Technical characteristics

	4-pole	5-pole	8-pole
Rated current (40°C)	4A	4A	2A
Rated voltage	250V	125V	60V
Rated impulse voltage	2500V	1500V	800V
Pollution degree	3	3	3
Overvoltage categorie	II	II	II
Contact resistance	≤ 10 mΩ	≤ 10 mΩ	≤ 10 mΩ
Connector locking system	screw	screw	screw
Termination	solder,dip solder	solder,dip solder	solder,dip solder
Wire gauge	max. 0.75mm <sup>2</sup> (max. AWG18)	max. 0.75mm <sup>2</sup> (max. AWG18)	max.0.34mm <sup>2</sup> (max.AWG22)
Cable outlet	-	-	-
Degree of protection	IP67	IP67	IP67
Mechanical operation	> 100	> 100	> 100
Limiting temperature	-40°C ...+85°C	-40°C ...+85°C	-40°C ...+85°C
Material group	II	II	II
Material of contact	copper alloy	copper alloy	copper alloy
Contact plating	Au	Au	Au
Insulating material	PA	PA	PA
Material of housing	zinc diecasting nickel plated	zinc diecasting nickel plated	zinc diecasting nickel plated

## Socket

Female panel mount connector, solder, front fastened



A-Code



Contacts	screw	Designation	Order No.
4	PG9	M12-F04A-BKR-PG9-C	163 004 323 1011
	M16x1.5	M12-F04A-BKR-M16-C	163 004 624 1003
5	PG9	M12-F05A-BKR-PG9-C	163 005 323 1011
	M16x1.5	M12-F05A-BKR-M16-C	163 005 624 1001
8	PG9	M12-F08A-BKR-PG9-C	163 008 323 1011
	M16x1.5	M12-F08A-BKR-M16-C	163 008 323 1012
12	PG9	M12-F12A-BKR-PG9-C	163 012 323 1502
	M16x1.5	M12-F12A-BKR-M16-C	163 012 323 1503

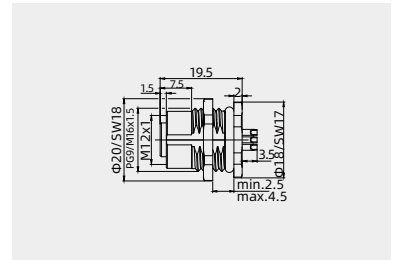

Female panel mount connector, dip solder



A-Code



Contacts	screw	Designation	Order No.
4	PG9	M12-F04A-BK-PG9-D	163 004 324 1001
	M16x1.5	M12-F04A-BK-M16-D	163 004 324 1002
5	PG9	M12-F05A-BK-PG9-D	163 005 324 1001
	M16x1.5	M12-F05A-BK-M16-D	163 005 324 1002
8	PG9	M12-F08A-BK-PG9-D	163 008 324 1003
	M16x1.5	M12-F08A-BK-M16-D	163 008 324 1001

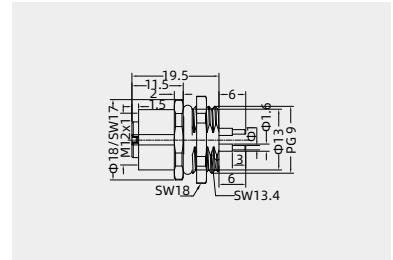

Female panel mount connector, dip solder, front fastened



A-Code



Contacts	screw	Designation	Order No.
4	PG9	M12-F04A-BKR-PG9-D	163 004 324 1011
	M16x1.5	M12-F04A-BKR-M16-D	163 004 624 1004
5	PG9	M12-F05A-BKR-PG9-D	163 005 324 1011
	M16x1.5	M12-F05A-BKR-M16-D	163 005 624 1002
8	PG9	M12-F08A-BKR-PG9-D	163 008 324 1011
	M16x1.5	M12-F08A-BKR-M16-D	163 008 624 1001

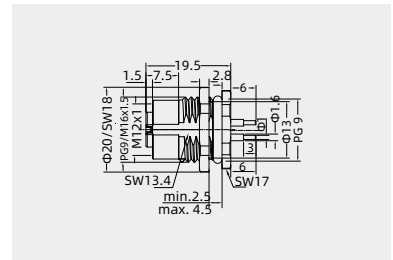

Accessories

Protection covers IP67

Protection cover  
for male cable connector



Description	Designation	Order No.
Without cord	M12-MCV	163 000 001 9003
With cord	M12-MCV/1	163 000 001 9001

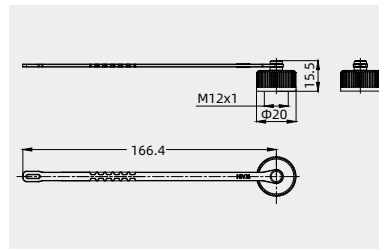

Protection cover  
for female cable connector



Description	Designation	Order No.
Without cord	M12-FCV	163 000 002 9003
With cord	M12-FCV/1	163 000 002 9001

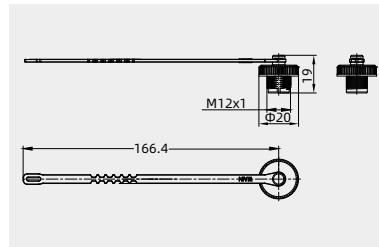

Hexagonal nut for fixing thread



screw	Designation	Order No.
PG9	WNA-PG9/S	102 105 002 1101
M16x1.5	WNA-M16/S	102 105 013 1101

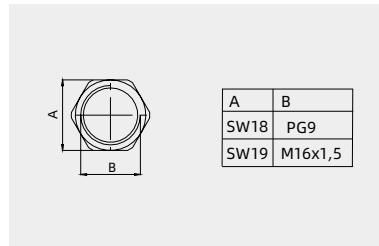

Protection covers, for flange  
mount panel



Description	Designation	Order No.
Dust-proof	M12-WNPP-M16/BK	163 000 000 9001

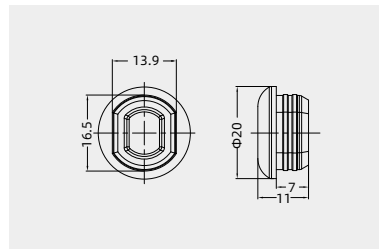

M12-A

• Contact arrangements

• Male insert (mating side)

4contacts



	X	Y	
1	2.50	0.00	1. brown
2	0.00	2.50	2. white
3	-2.50	0.00	3. blue
4	0.00	-2.50	4. black

5contacts

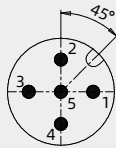

	X	Y	
1	2.50	0.00	1. brown
2	0.00	2.50	2. white
3	-2.50	0.00	3. blue
4	0.00	-2.50	4. black
5	0.00	0.00	5. grey

8contacts

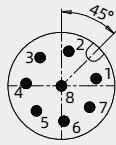

	X	Y	
1	2.69	0.57	1. white
2	0.57	2.69	2. brown
3	-1.66	2.20	3. green
4	-2.75	0.19	4. yellow
5	-1.94	-1.94	5. grey
6	0.19	-2.74	6. pink
7	2.20	-1.65	7. blue
8	0.00	0.00	8. red

• Female insert (mating side)

4contacts

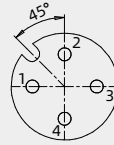

	X	Y	
1	-2.50	0.00	1. brown
2	0.00	2.50	2. white
3	2.50	0.00	3. blue
4	0.00	-2.50	4. black

5contacts



	X	Y	
1	-2.50	0.00	1. brown
2	0.00	2.50	2. white
3	2.50	0.00	3. blue
4	0.00	-2.50	4. black
5	0.00	0.00	5. grey

8contacts



	X	Y	
1	-2.69	0.57	1. white
2	0.57	2.69	2. brown
3	1.66	2.20	3. green
4	2.75	0.19	4. yellow
5	1.94	-1.94	5. grey
6	-0.19	-2.75	6. pink
7	-2.20	-1.66	7. blue
8	0.00	0.00	8. red

• Panel cut out

- Opening hole drawing male insert(PCB), Panel mount connectors

- Opening hole drawing female insert(PCB), Panel mount connectors

4contacts

4contacts

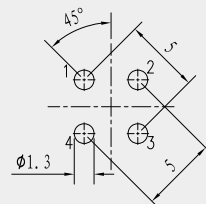
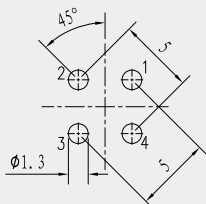

5contacts

5contacts

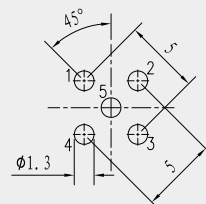
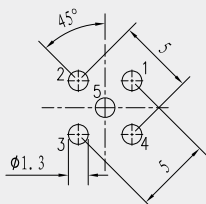

8contacts

8contacts

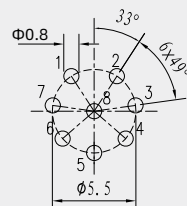
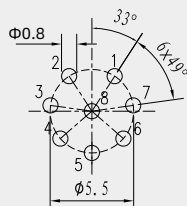

• Panel cut out

• Panel mount connectors

• Through-hole mounting

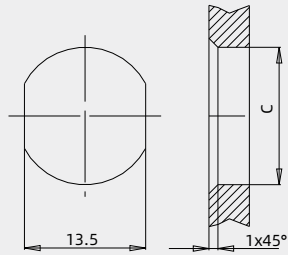

• Screw mounting

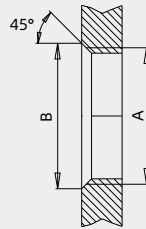

	A	B	C
PG9	PG9	16.2	15.3
PG13.5	PG13.5	21.5	20.5
M16x1.5	M16x1.5	17.0	16.1
M20x1.5	M20x1.5	21.0	20.1

Tightening torque according to DIN VDE 0619  
 Metal housing 6,25 Nm  
 Plastic housing 3,75 Nm

• Panel mount connectors

Rear panel mounting,  
 front tighten

• Through-hole mounting

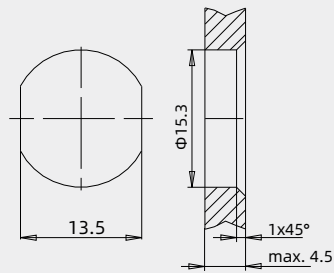

• Panel mount connectors

front tighten

• 通孔安装

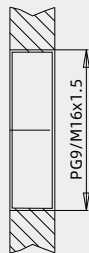

Tightening torque 6,25 Nm



M12-A

## M12 Circular Connector,B-coded



- Cable Connector

- Shielded / unshielded series
- Installable series and moulded cable series
- Thread locking M12X1
- Screw terminal
- Shielding ring and ring spring shielding connection
- Cable length 1.5m and 5m
- Other cable length upon request, minimum order quantity 200 pieces
- Cable material can be customized according to requirements
- Degree of protection IP67
- Anti-loose spring with nut



## M12-B Circular Connector

125/250V 4A

## Technical characteristics

	4-pole	5-pole
Rated current(40°C )	4A	4A
Rated voltage	250V	125V
Rated impulse voltage	2500V	1500V
Pollution degree	3	3
Overvoltage categorie	II	II
Contact resistance	≤ 10 mΩ	≤ 10 mΩ
Connector locking system	screw M12x1	screw M12x1
Termination	screw	screw
Wire gauge	max.0.75mm <sup>2</sup> (max.AWG18)	max.0.75mm <sup>2</sup> (max.AWG18)
Cable outlet	4-6,6-8 mm	4-6,6-8 mm
Degree of protection	IP67	IP67
Mechanical operation	> 100	> 100
Limiting temperature	-40°C ...+85°C	-40°C ...+85°C
Material group	III	III
Material of contact	copper alloy	copper alloy
Contact plating	Au	Au
Insulating material	PA	PA
Material of housing	PA/PBT	PA/PBT

## Straight cable connectors

Male cable connector, plastic locking system, screw clamp connection

Contacts	Cable outlet	Designation	Order No.
4	4-6 mm	M12P-M04B-T-D6	163 004 411 3105
	6-8 mm	M12P-M04B-T-D8	163 004 411 3106
5	4-6 mm	M12P-M05B-T-D6	163 005 411 3105
	6-8 mm	M12P-M05B-T-D8	163 005 411 3106

B-Code

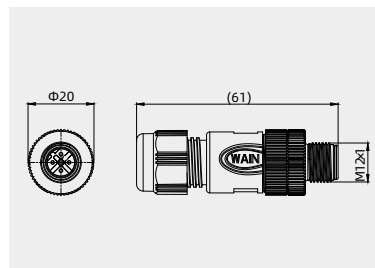

Male cable connector, metal locking system, screw clamp connection

Recommended use

Contacts	Cable outlet	Designation	Order No.
4	4-6 mm	M12-M04B-T-D6	163 004 411 1001
	6-8 mm	M12-M04B-T-D8	163 004 411 1002
5	4-6 mm	M12-M05B-T-D6	163 005 411 1001
	6-8 mm	M12-M05B-T-D8	163 105 411 3002

B-Code

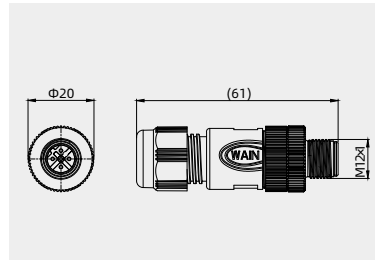

Male cable connector, stainless steel locking system, screw clamp connection

Contacts	Cable outlet	Designation	Order No.
4	4-6 mm	M12S-M04B-T-D6	163 004 411 1003
	6-8 mm	M12S-M04B-T-D8	163 004 411 1004
5	4-6 mm	M12S-M05B-T-D6	163 005 411 1003
	6-8 mm	M12S-M05B-T-D8	163 005 411 1004

B-Code

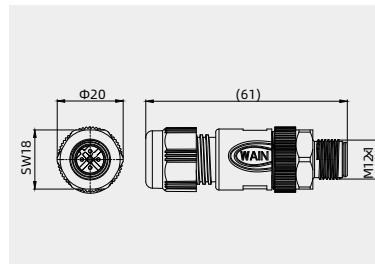

## M12-B Circular Connector

125/250V 4A



## Technical characteristics

	3-pole	4-pole	5-pole
Rated current(40°C )	4A	4A	4A
Rated voltage	250V	250V	125V
Rated impulse voltage	2500V	2500V	1500V
Pollution degree	3	3	3
Overvoltage categorie	II	II	II
Contact resistance	≤ 10 mΩ	≤ 10 mΩ	≤ 10 mΩ
Connector locking system	screw M12x1	screw M12x1	screw M12x1
Termination	screw	screw	screw
Wire gauge	max.0.75mm <sup>2</sup> (max.AWG18)	max.0.75mm <sup>2</sup> (max.AWG18)	max.0.75mm <sup>2</sup> (max.AWG18)
Cable outlet	4-8mm	4-8mm	4-8mm
Degree of protection	IP67	IP67	IP67
Mechanical operation	> 100	> 100	> 100
Limiting temperature	-40°C ...+85°C	-40°C ...+85°C	-40°C ...+85°C
Material group	II	II	II
Contact material	copper alloy	copper alloy	copper alloy
Surface finishes	Au	Au	Au
Material of housing	PA/PBT/zinc alloy/copper alloy	PA/PBT/zinc alloy/copper alloy	PA/PBT/zinc alloy/copper alloy

## Straight cable connectors

Male cable connector, plastic locking system, screw clamp connection



B-Code



Contacts	Cable outlet	Designation	Order No.
3	4-6 mm	M12P-MST03B-T-D6	163 003 413 3506
	6-8 mm	M12P-MST03B-T-D8	163 003 413 3507
4	4-6 mm	M12P-MST04B-T-D6	163 004 413 3511
	6-8 mm	M12P-MST04B-T-D8	163 004 413 3512
5	4-6 mm	M12P-MST05B-T-D6	163 005 413 3511
	6-8 mm	M12P-MST05B-T-D8	163 005 4133512

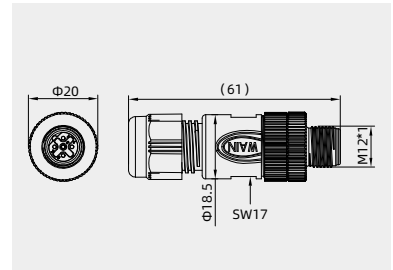

Male cable connector, metal locking system, screw clamp connectionsystem



B-Code



Contacts	Cable outlet	Designation	Order No.
3	4-6 mm	M12-MST03B-T-D6	163 003 413 3508
	6-8 mm	M12-MST03B-T-D8	163 003 413 3509
4	4-6 mm	M12-MST04B-T-D6	163 004 413 3513
	6-8 mm	M12-MST04B-T-D8	163 004 413 3514
5	4-6 mm	M12-MST05B-T-D6	163 005 413 3513
	6-8 mm	M12-MST05B-T-D8	163 005 413 3510

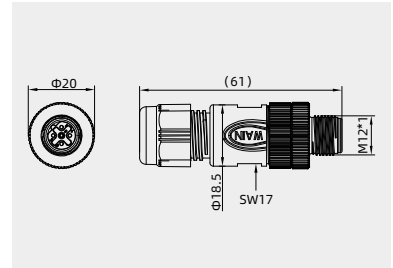

Male cable connector, stainless steel locking system, screw clamp connection



B-Code



Contacts	Cable outlet	Designation	Order No.
3	4-6 mm	M12S-MST03B-T-D6	163 003 413 3510
	6-8 mm	M12S-MST03B-T-D8	163 003 413 3511
4	4-6 mm	M12S-MST04B-T-D6	163 004 413 3515
	6-8 mm	M12S-MST04B-T-D8	163 004 413 3516
5	4-6 mm	M12S-MST05B-T-D6	163 005 413 3514
	6-8 mm	M12S-MST05B-T-D8	163 005 413 3515

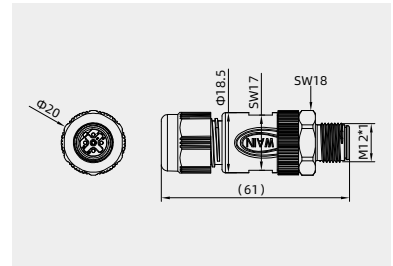

## M12-B Circular Connector

125/250V 2/8A

## Technical characteristics

	4-pole	5-pole
Rated current(40°C )	4A	Contacts:1-4 8A; Contacts:5 2A
Rated voltage	250V	125V
Rated impulse voltage	2500V	1500V
Pollution degree	3	3
Overvoltage categorie	II	II
Contact resistance	≤ 10 mΩ	≤ 10 mΩ
Connector locking system	screw M12x1	screw M12x1
Termination	screw	screw terminal/solde terminal
Wire gauge	max.0.75mm <sup>2</sup> (max.AWG18)	max.1.5mm <sup>2</sup> (max.AWG16)/max.0.75mm <sup>2</sup> (max.AWG18)
Cable outlet	8-10mm	8-10mm
Degree of protection	IP67	IP67
Mechanical operation	> 100	> 100
Limiting temperature	-40°C ...+85°C	-40°C ...+85°C
Material group	II	II
Material of contact	copper alloy	copper alloy
Contact plating	Au	Au
Insulating material	PA	PA
Material of housing	PA/PBT/zinc alloy/copper alloy	PA/PBT/zinc alloy/copper alloy

## Straight cable connectors

Male cable connector, plastic locking system, screw clamp connection

Contacts	Cable outlet	Designation	Order No.
5	8-10 mm	M12P-M05B-T-D10	163 005 411 3107

B-Code



5pin

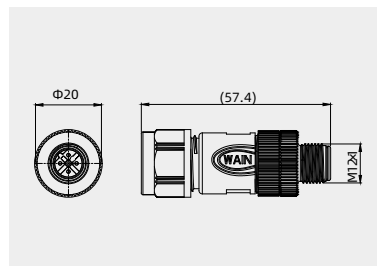

Male cable connector, metal locking system, screw clamp connection

Recommended use

Contacts	Cable outlet	Designation	Order No.
5	8-10 mm	M12-M05B-T-D10	163 005 411 1002

B-Code



5pin

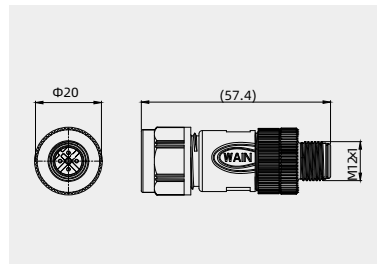

Male cable connector, stainless steel locking system, screw clamp connection

Contacts	Cable outlet	Designation	Order No.
5	8-10 mm	M12S-M05B-T-D10	163 005 411 1005

B-Code



5pin

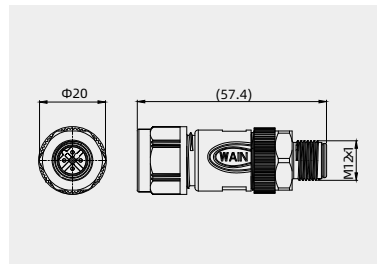

Male cable connector, metal locking system, solde terminal

插针数	电缆出口直径	型号	订货号
4	8-10 mm	M12-MST04B-T-D10	163 004 413 3517
5	8-10 mm	M12-MST05B-T-D10	163 005 413 3516

B-Code



4pin



5pin

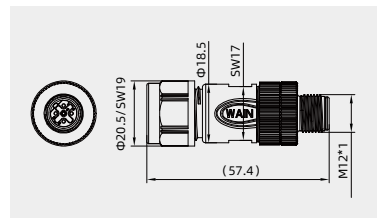

## M12-B Circular Connector

125/250V 4A

## Technical characteristics

	3-pole	4-pole	5-pole
Rated current(40°C )	4A	4A	4A
Rated voltage	250V	250V	125V
Rated impulse voltage	2500V	2500V	1500V
Pollution degree	3	3	3
Overvoltage categorie	II	II	II
Contact resistance	≤ 10 mΩ	≤ 10 mΩ	≤ 10 mΩ
Connector locking system	screw M12x1	screw M12x1	screw M12x1
Termination	solde terminal	screw terminal/solde terminal	screw terminal/solde terminal
Wire gauge	max.0.75mm <sup>2</sup> (max.AWG18)	max.0.75mm <sup>2</sup> (max.AWG18)	max.0.75mm <sup>2</sup> (max.AWG18)
Cable outlet	4-10mm	4-10mm	4-10mm
Degree of protection	IP67	IP67	IP67
Mechanical operation	> 100	> 100	> 100
Limiting temperature	-40°C ...+85°C	-40°C ...+85°C	-40°C ...+85°C
Material group	II	II	II
Material of contact	copper alloy	copper alloy	copper alloy
Contact plating	Au	Au	Au
Insulating material	PA	PA	PA
Material of housing	PA/PBT/zinc alloy/copper alloy	PA/PBT/zinc alloy/copper alloy	PA/PBT/zinc alloy/copper alloy

## Straight cable connectors, shielded

Male cable connector, shielded,  
screw clamp connection,  
with shielding ring  
**Recommended use**



B-Code



Contacts	Cable outlet	Designation	Order No.
4	4-6 mm	M12-M04B-T-D6-SH	163 004 411 2006
	6-8 mm	M12-M04B-T-D8-SH	163 004 411 2007
	8-10 mm	M12-M04B-T-D10-SH	163 004 411 2504
5	4-6 mm	M12-M05B-T-D6-SH	163 005 411 2007
	6-8 mm	M12-M05B-T-D8-SH	163 005 411 2008
	8-10 mm	M12-M05B-T-D10-SH	163 005 411 2503

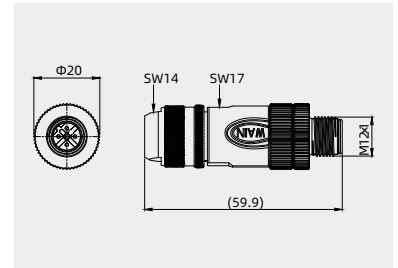

Male cable connector, shielded,  
solde terminal, with shielding ring



B-Code



Contacts	Cable outlet	Designation	Order No.
3	4-6 mm	M12-MST03B-T-D6-SH	163 003 413 3512
	6-8 mm	M12-MST03B-T-D8-SH	163 003 413 3513
4	4-6 mm	M12-MST04B-T-D6-SH	163 004 413 2500
	6-8 mm	M12-MST04B-T-D8-SH	163 004 413 2501
5	4-6 mm	M12-MST05B-T-D6-SH	163 005 413 2500
	6-8 mm	M12-MST05B-T-D8-SH	163 005 413 2501

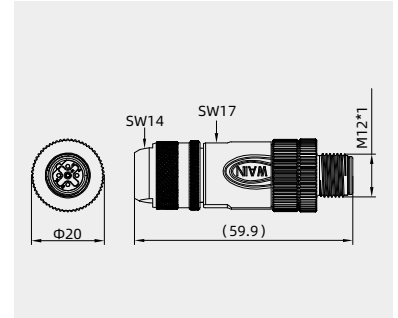

## M12-B Circular Connector

125/250V 4A

## Technical characteristics

	4-pole	5-pole
Rated current(40°C )	4A	4A
Rated voltage	250V	125V
Rated impulse voltage	2500V	1500V
Pollution degree	3	3
Overvoltage categorie	II	II
Contact resistance	≤ 10 mΩ	≤ 10 mΩ
Connector locking system	screw M12x1	screw M12x1
Termination	screw	screw
Wire gauge	max.0.75mm <sup>2</sup> (max.AWG18)	max.0.75mm <sup>2</sup> (max.AWG18)
Cable outlet	4-6,6-8 mm	4-6,6-8 mm
Degree of protection	IP67	IP67
Mechanical operation	> 100	> 100
Limiting temperature	-40°C ...+85°C	-40°C ...+85°C
Material group	II	II
Material of contact	copper alloy	copper alloy
Contact plating	Au	Au
Insulating material	PA	PA
Material of housing	PA/PBT	PA/PBT

## Angled cable connectors

Male cable connector, plastic locking system, screw clamp connection



Contacts	Cable outlet	Designation	Order No.
4	4-6 mm	M12P-M04B-S-D6	163 004 511 3105
	6-8 mm	M12P-M04B-S-D8	163 004 511 3106
5	4-6 mm	M12P-M05B-S-D6	163 005 511 3105
	6-8 mm	M12P-M05B-S-D8	163 005 511 3106

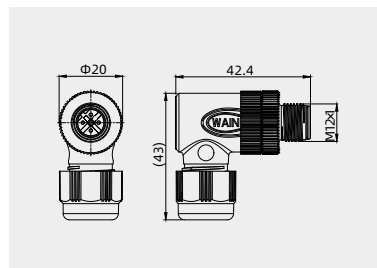

Male angled connector, metal locking system, screw clamp connection



Contacts	Cable outlet	Designation	Order No.
4	4-6 mm	M12-M04B-S-D6	163 004 511 1001
	6-8 mm	M12-M04B-S-D8	163 004 511 1002
5	4-6 mm	M12-M05B-S-D6	163 005 511 1001
	6-8 mm	M12-M05B-S-D8	163 005 511 1002

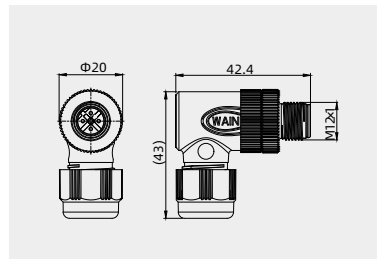

Male cable connector, stainless steel locking system, screw clamp connection



Contacts	Cable outlet	Designation	Order No.
4	4-6 mm	M12S-M04B-S-D6	163 004 511 1003
	6-8 mm	M12S-M04B-S-D8	163 004 511 1004
5	4-6 mm	M12S-M05B-S-D6	163 005 511 1004
	6-8 mm	M12S-M05B-S-D8	163 005 511 1005

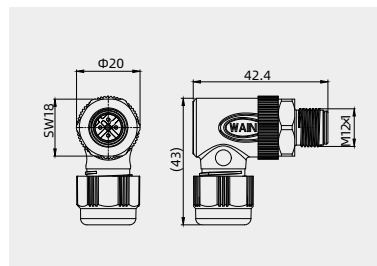

## M12-B Circular Connector

125/250V 4A



## Technical characteristics

	3-pole	4-pole	5-pole
Rated current(40°C )	4A	4A	4A
Rated voltage	250V	250V	125V
Rated impulse voltage	2500V	2500V	1500V
Pollution degree	3	3	3
Overvoltage categorie	II	II	II
Contact resistance	≤ 10 mΩ	≤ 10 mΩ	≤ 10 mΩ
Connector locking system	screw M12x1	screw M12x1	screw M12x1
Termination	solde terminal	solde terminal	solde terminal
Wire gauge	max.0.75mm <sup>2</sup> (max.AWG18)	max.0.75mm <sup>2</sup> (max.AWG18)	max.0.75mm <sup>2</sup> (max.AWG18)
Cable outlet	4-8mm	4-8mm	4-8mm
Degree of protection	IP67	IP67	IP67
Mechanical operation	> 100	> 100	> 100
Limiting temperature	-40°C ...+85°C	-40°C ...+85°C	-40°C ...+85°C
Material group	II	II	II
Contact material	copper alloy	copper alloy	copper alloy
Surface finishes	Au	Au	Au
Material of housing	PA/PBT/zinc alloy/copper alloy	PA/PBT/zinc alloy/copper alloy	PA/PBT/zinc alloy/copper alloy

## Angled cable connectors

Male cable connector, plastic locking system, solde terminal



B-Code



Contacts	Cable outlet	Designation	Order No.
3	4-6 mm	M12P-MST03B-S-D6	163 003 513 3506
	6-8 mm	M12P-MST03B-S-D8	163 003 513 3507
4	4-6 mm	M12P-MST04B-S-D6	163 004 513 3508
	6-8 mm	M12P-MST04B-S-D8	163 004 513 3509
5	4-6 mm	M12P-MST05B-S-D6	163 005 513 3508
	6-8 mm	M12P-MST05B-S-D8	163 005 513 3509

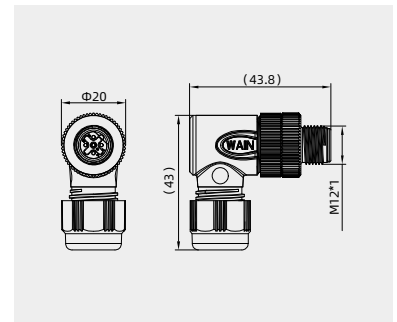

Male cable connector, metal locking system, solde terminal



B-Code



Contacts	Cable outlet	Designation	Order No.
3	4-6 mm	M12-MST03B-S-D6	163 003 513 3508
	6-8 mm	M12-MST03B-S-D8	163 003 513 3509
4	4-6 mm	M12-MST04B-S-D6	163 004 513 3510
	6-8 mm	M12-MST04B-S-D8	163 004 513 3511
5	4-6 mm	M12-MST05B-S-D6	163 005 513 3510
	6-8 mm	M12-MST05B-S-D8	163 005 513 3511

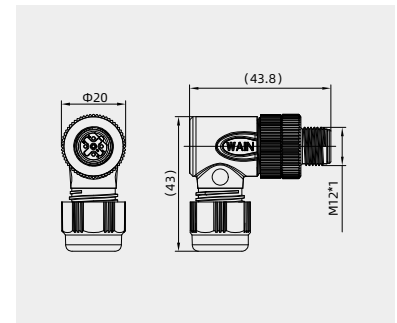

Male cable connector, stainless steel locking system, solde terminal



B-Code



Contacts	Cable outlet	Designation	Order No.
3	4-6 mm	M12S-MST03B-S-D6	163 003 513 3510
	6-8 mm	M12S-MST03B-S-D8	163 003 513 3511
4	4-6 mm	M12S-MST04B-S-D6	163 004 513 3512
	6-8 mm	M12S-MST04B-S-D8	163 004 513 3513
5	4-6 mm	M12S-MST05B-S-D6	163 005 513 3512
	6-8 mm	M12S-MST05B-S-D8	163 005 513 3513

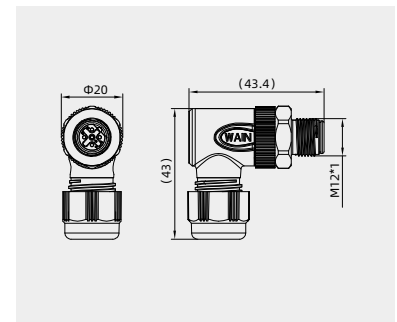

## M12-B Circular Connector

125/250V 2/8A

## Technical characteristics

	5-pole
Rated current(40°C )	Contacts:1-4 8A; Contacts:5 2A
Rated voltage	125V
Rated impulse voltage	1500V
Pollution degree	3
Overvoltage categorie	II
Contact resistance	≤ 10 mΩ
Connector locking system	screw M12x1
Termination	screw
Wire gauge	max.1.5mm <sup>2</sup> (max.AWG16)
Cable outlet	8-10mm
Degree of protection	IP67
Mechanical operation	> 100
Limiting temperature	-40°C ...+85°C
Material group	II
Material of contact	copper alloy
Contact plating	Au
Insulating material	PA
Material of housing	PA/PBT

## Angled cable connectors

Male cable connector, plastic locking system, screw clamp connection

Contacts	Cable outlet	Designation	Order No.
5	8-10 mm	M12P-M05B-S-D10	163 005 511 3107

B-Code



5pin

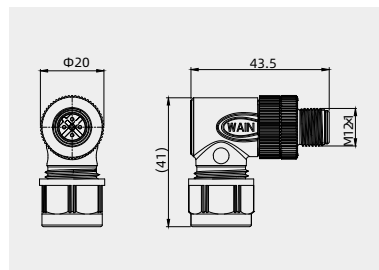

Male cable connector, metal locking system, screw clamp connection

Recommended use

Contacts	Cable outlet	Designation	Order No.
5	8-10 mm	M12-M05B-S-D10	163 005 511 1003

B-Code



5pin

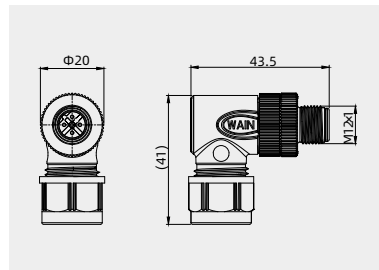

Male cable connector, stainless steel locking system, screw clamp connection

Contacts	Cable outlet	Designation	Order No.
5	8-10 mm	M12S-M05B-S-D10	163 005 511 1006

B-Code



5pin

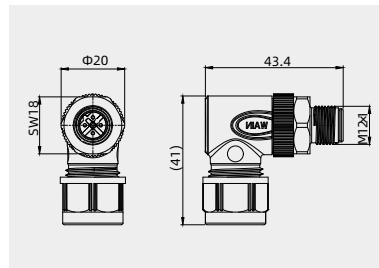

## M12-B Circular Connector

125/250V 4A

## Technical characteristics

	4-pole	4-pole	5-pole
Rated current(40°C )	4A	4A	4A
Rated voltage	250V	250V	125V
Rated impulse voltage	2500V	2500V	1500V
Pollution degree	3	3	3
Overvoltage categorie	II	II	II
Contact resistance	≤ 10 mΩ	≤ 10 mΩ	≤ 10 mΩ
Connector locking system	screw M12x1	screw M12x1	screw M12x1
Termination	solde terminal	screw terminal/solde terminal	screw terminal/solde terminal
Wire gauge	max.0.75mm <sup>2</sup> (max.AWG18)	max.0.75mm <sup>2</sup> (max.AWG18)	max.0.75mm <sup>2</sup> (max.AWG18)
Cable outlet	4-8mm	4-8mm	4-8mm
Degree of protection	IP67	IP67	IP67
Mechanical operation	> 100	> 100	> 100
Limiting temperature	-40°C ...+85°C	-40°C ...+85°C	-40°C ...+85°C
Material group	II	II	II
Material of contact	copper alloy	copper alloy	copper alloy
Contact plating	Au	Au	Au
Insulating material	PA	PA	PA
Material of housing	PA/PBT/zinc alloy/copper alloy	PA/PBT/zinc alloy/copper alloy	PA/PBT/zinc alloy/copper alloy

## Angled cable connectors, shielded

Male cable connector, shielded,  
screw clamp connection,  
with shielding ring

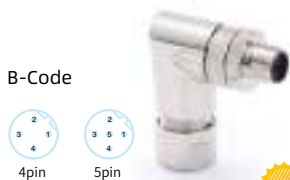

B-Code



Contacts	Cable outlet	Designation	Order No.
4	4-6 mm	M12-M04B-S-D6-SH	163 004 511 2003
	6-8 mm	M12-M04B-S-D8-SH	163 004 511 2004
5	4-6 mm	M12-M05B-S-D6-SH	163 005 511 2003
	6-8 mm	M12-M05B-S-D8-SH	163 005 511 2004

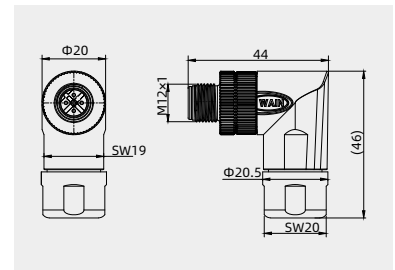

Male cable connector, shielded,  
solde terminal, with shielding ring



B-Code



Contacts	Cable outlet	Designation	Order No.
3	4-6 mm	M12-MST03B-S-D6-SH	163 003 513 2502
	6-8 mm	M12-MST03B-S-D8-SH	163 003 513 2503
4	4-6 mm	M12-MST04B-S-D6-SH	163 004 513 2502
	6-8 mm	M12-MST04B-S-D8-SH	163 004 513 2503
5	4-6 mm	M12-MST05B-S-D6-SH	163 005 513 3516
	6-8 mm	M12-MST05B-S-D8-SH	163 005 513 2502

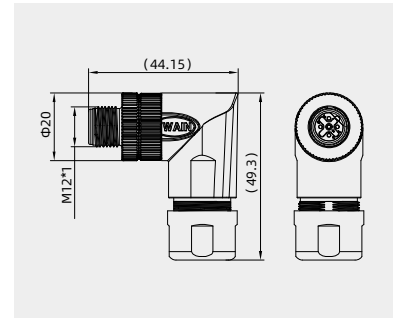



## M12-B Circular Connector

125/250V 4A

## Technical characteristics

	4-pole	5-pole
Rated current(40°C )	4A	4A
Rated voltage	250V	125V
Rated impulse voltage	2500V	1500V
Pollution degree	3	3
Overvoltage categorie	II	II
Contact resistance	≤ 10 mΩ	≤ 10 mΩ
Connector locking system	screw M12x1	screw M12x1
Termination	screw	screw
Wire gauge	max.0.75mm <sup>2</sup> (max.AWG18)	max.0.75mm <sup>2</sup> (max.AWG18)
Cable outlet	4-6,6-8 mm	4-6,6-8 mm
Degree of protection	IP67	IP67
Mechanical operation	> 100	> 100
Limiting temperature	-40°C ...+85°C	-40°C ...+85°C
Material group	III	III
Material of contact	copper alloy	copper alloy
Contact plating	Au	Au
Insulating material	PA	PA
Material of housing	PA/PBT	PA/PBT

## Straight cable connectors

Female cable connector,  
plastic locking system,  
screw clamp connection



B-Code



Contacts	Cable outlet	Designation	Order No.
4	4-6 mm	M12P-F04B-T-D6	163 004 421 3106
	6-8 mm	M12P-F04B-T-D8	163 004 421 3107
5	4-6 mm	M12P-F05B-T-D6	163 005 421 3106
	6-8 mm	M12P-F05B-T-D8	163 005 421 3107

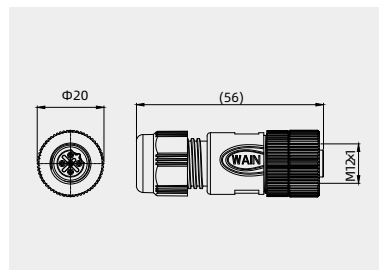

Female cable connector,  
metal locking system,  
screw clamp connection

Recommended use



B-Code



Contacts	Cable outlet	Designation	Order No.
4	4-6 mm	M12-F04B-T-D6	163 004 421 1001
	6-8 mm	M12-F04B-T-D8	163 004 421 1002
5	4-6 mm	M12-F05B-T-D6	163 005 421 1001
	6-8 mm	M12-F05B-T-D8	163 105 421 3002

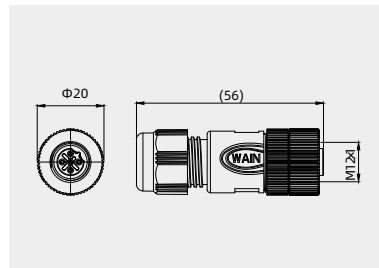

Female cable connector,  
stainless steel locking system,  
screw clamp connection,



B-Code



Contacts	Cable outlet	Designation	Order No.
4	4-6 mm	M12S-F04B-T-D6	163 004 421 1003
	6-8 mm	M12S-F04B-T-D8	163 004 421 1004
5	4-6 mm	M12S-F05B-T-D6	163 005 421 1003
	6-8 mm	M12S-F05B-T-D8	163 005 421 1004

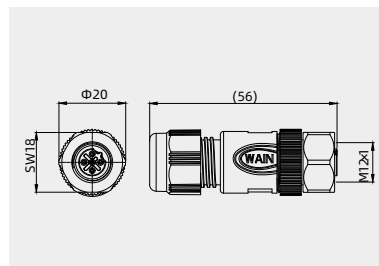

## M12-B Circular Connector

125/250V 4A



## Technical characteristics

	3-pole	4-pole	5-pole
Rated current(40°C )	4A	4A	4A
Rated voltage	250V	250V	125V
Rated impulse voltage	2500V	2500V	1500V
Pollution degree	3	3	3
Overvoltage categorie	II	II	II
Contact resistance	≤ 10 mΩ	≤ 10 mΩ	≤ 10 mΩ
Connector locking system	screw M12x1	screw M12x1	screw M12x1
Termination	solde terminal	solde terminal	solde terminal
Wire gauge	max.0.75mm <sup>2</sup> (max.AWG18)	max.0.75mm <sup>2</sup> (max.AWG18)	max.0.75mm <sup>2</sup> (max.AWG18)
Cable outlet	4-8mm	4-10mm	4-10mm
Degree of protection	IP67	IP67	IP67
Mechanical operation	> 100	> 100	> 100
Limiting temperature	-40°C ...+85°C	-40°C ...+85°C	-40°C ...+85°C
Material group	II	II	II
Contact material	copper alloy	copper alloy	copper alloy
Surface finishes	Au	Au	Au
Material of housing	PA/PBT/zinc alloy/copper alloy	PA/PBT/zinc alloy/copper alloy	PA/PBT/zinc alloy/copper alloy

## Straight cable connectors

Male cable connector, plastic locking system, solde terminal



B-Code



Contacts	Cable outlet	Designation	Order No.
3	4-6 mm	M12P-FST03B-T-D6	163 003 423 3506
	6-8 mm	M12P-FST03B-T-D8	163 003 423 3507
4	4-6 mm	M12P-FST04B-T-D6	163 004 423 3510
	6-8 mm	M12P-FST04B-T-D8	163 004 423 3511
5	4-6 mm	M12P-FST05B-T-D6	163 005 423 3511
	6-8 mm	M12P-FST05B-T-D8	163 005 423 3512

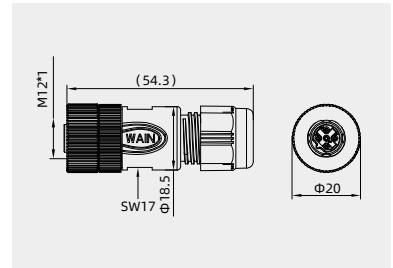

Male cable connector, metal locking system, solde terminal



B-Code



Contacts	Cable outlet	Designation	Order No.
3	4-6 mm	M12-FST03B-T-D6	163 003 423 3508
	6-8 mm	M12-FST03B-T-D8	163 003 423 3509
4	4-6 mm	M12-FST04B-T-D6	163 004 423 3512
	6-8 mm	M12-FST04B-T-D8	163 004 423 3513
5	4-6 mm	M12-FST05B-T-D6	163 005 423 3513
	6-8 mm	M12-FST05B-T-D8	163 005 423 3510

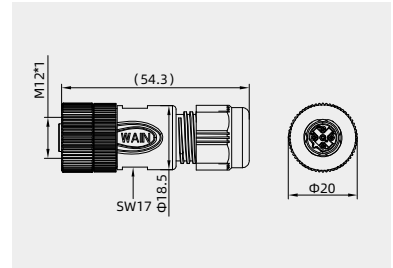

Male cable connector, stainless steel locking system, solde terminal



B-Code



Contacts	Cable outlet	Designation	Order No.
3	4-6 mm	M12S-FST03B-T-D6	163 003 423 3510
	6-8 mm	M12S-FST03B-T-D8	163 003 423 3511
4	4-6 mm	M12S-FST04B-T-D6	163 004 423 3514
	6-8 mm	M12S-FST04B-T-D8	163 004 423 3515
5	4-6 mm	M12S-FST05B-T-D6	163 005 423 3514
	6-8 mm	M12S-FST05B-T-D8	163 005 423 3515

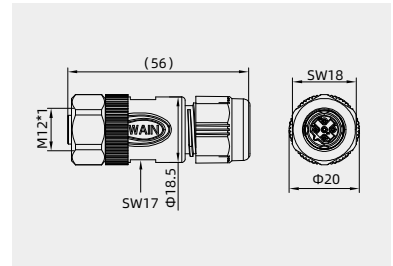

## M12-B Circular Connector

125/250V 2/8A

## Technical characteristics

	4-pole	5-pole
Rated current(40°C )	4A	Contacts:1-4 8A; Contacts:5 2A
Rated voltage	250V	125V
Rated impulse voltage	2500V	1500V
Pollution degree	3	3
Overvoltage categorie	II	II
Contact resistance	≤ 10 mΩ	≤ 10 mΩ
Connector locking system	screw M12x1	screw M12x1
Termination	solde terminal	screw terminal/solde terminal
Wire gauge	max.0.75mm <sup>2</sup> (max.AWG18)	max.0.75mm <sup>2</sup> (max.AWG18)
Cable outlet	8-10mm	8-10mm
Degree of protection	IP67	IP67
Mechanical operation	> 100	> 100
Limiting temperature	-40°C ...+85°C	-40°C ...+85°C
Material group	II	II
Material of contact	copper alloy	copper alloy
Contact plating	Au	Au
Insulating material	PA	PA
Material of housing	PA/PBT/zinc alloy/copper alloy	PA/PBT/zinc alloy/copper alloy

## Straight cable connectors

Female cable connector,  
plastic locking system,  
screw clamp connection

Contacts	Cable outlet	Designation	Order No.
5	8-10 mm	M12P-F05B-T-D10	163 005 421 3108

B-Code



5pin

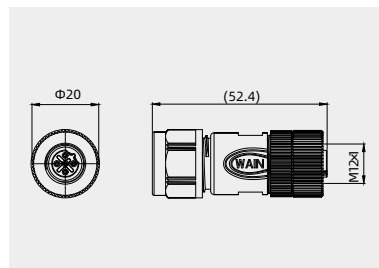

Female cable connector,  
metal locking system,  
screw clamp connection

Contacts	Cable outlet	Designation	Order No.
5	8-10 mm	M12-F05B-T-D10	163 005 421 1002

Recommended use

B-Code



5pin

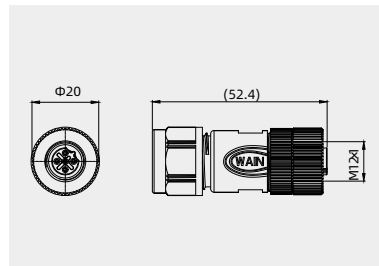

Female cable connector,  
stainless steel locking system,  
screw clamp connection

Contacts	Cable outlet	Designation	Order No.
5	8-10 mm	M12S-F05B-T-D10	163 005 421 1005

B-Code



5pin

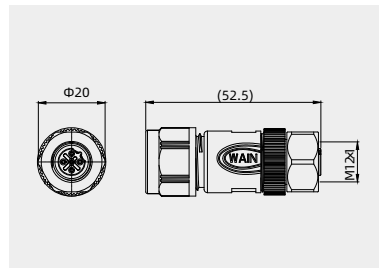

Female cable connector,  
stainless steel locking system,  
solde terminal

Contacts	Cable outlet	Designation	Order No.
4	8-10 mm	M12-FST04B-T-D10	163 004 423 3516
5	8-10 mm	M12-FST05B-T-D10	163 005 423 3516

B-Code



4pin



5pin

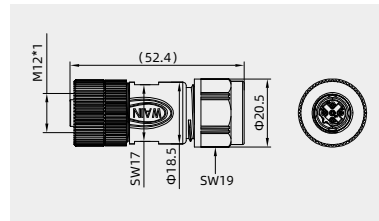

## M12-B Circular Connector

125/250V 4A

## Technical characteristics

	3-pole	4-pole	5-pole
Rated current(40°C )	4A	4A	4A
Rated voltage	250V	250V	125V
Rated impulse voltage	2500V	2500V	1500V
Pollution degree	3	3	3
Overvoltage categorie	II	II	II
Contact resistance	≤ 10 mΩ	≤ 10 mΩ	≤ 10 mΩ
Connector locking system	screw M12x1	screw M12x1	screw M12x1
Termination	solde terminal	screw terminal/solde terminal	screw terminal/solde terminal
Wire gauge	max.0.75mm <sup>2</sup> (max.AWG18)	max.0.75mm <sup>2</sup> (max.AWG18)	max.0.75mm <sup>2</sup> (max.AWG18)
Cable outlet	4-6,6-8mm	4-6,6-8mm	4-6,6-8mm
Degree of protection	IP67	IP67	IP67
Mechanical operation	> 100	> 100	> 100
Limiting temperature	-40°C ...+85°C	-40°C ...+85°C	-40°C ...+85°C
Material group	II	II	II
Material of contact	copper alloy	copper alloy	copper alloy
Contact plating	Au	Au	Au
Insulating material	PA	PA	PA
Material of housing	zinc diecasting nickel plated, brass nickel plated	zinc diecasting nickel plated, brass nickel plated	zinc diecasting nickel plated, brass nickel plated

## Straight cable connectors, shielded

Female cable connector, shielded,

screw clamp connection,  
with shielding ring

Recommended use



B-Code



4pin 5pin

Contacts	Cable outlet	Designation	Order No.
4	4-6 mm	M12-F04B-T-D6-SH	163 104 421 2001
	6-8 mm	M12-F04B-T-D8-SH	163 004 421 2005
	8-10 mm	M12-F04B-T-D10-SH	163 004 421 2503
5	4-6 mm	M12-F05B-T-D6-SH	163 005 421 2006
	6-8 mm	M12-F05B-T-D8-SH	163 105 421 3003
	8-10 mm	M12-F05B-T-D10-SH	163 005 421 2503

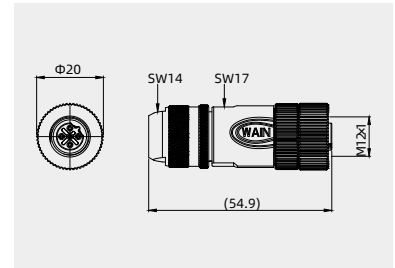

Female cable connector, shielded,

solde terminal, with shielding ring



B-Code



3pin 4pin 5pin

Contacts	Cable outlet	Designation	Order No.
3	4-6 mm	M12-FST03B-T-D6-SH	163 003 423 2502
	6-8 mm	M12-FST03B-T-D8-SH	163 003 423 2503
4	4-6 mm	M12-FST04B-T-D6-SH	163 004 423 2501
	6-8 mm	M12-FST04B-T-D8-SH	163 004 423 2502
5	4-6 mm	M12-FST05B-T-D6-SH	163 005 423 2500
	6-8 mm	M12-FST05B-T-D8-SH	163 005 423 2501

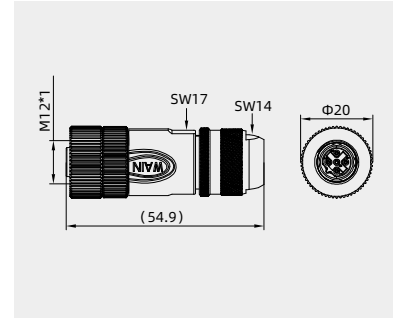

## M12-B Circular Connector

125/250V 4A

## Technical characteristics

	4-pole	5-pole
Rated current(40°C)	4A	4A
Rated voltage	250V	125V
Rated impulse voltage	2500V	1500V
Pollution degree	3	3
Overvoltage categorie	II	II
Contact resistance	≤ 10 mΩ	≤ 10 mΩ
Connector locking system	screw M12x1	screw M12x1
Termination	screw	screw
Wire gauge	max.0.75mm <sup>2</sup> (max.AWG18)	max.0.75mm <sup>2</sup> (max.AWG18)
Cable outlet	4-6,6-8 mm	4-6,6-8 mm
Degree of protection	IP67	IP67
Mechanical operation	> 100	> 100
Limiting temperature	-40°C ...+85°C	-40°C ...+85°C
Material group	II	II
Material of contact	copper alloy	copper alloy
Contact plating	Au	Au
Insulating material	PA	PA
Material of housing	PA/PBT	PA/PBT

## Angled cable connectors

Female cable connector,  
plastic locking system,  
screw clamp connection



Contacts	Cable outlet	Designation	Order No.
4	4-6 mm	M12P-F04B-S-D6	163 004 521 3105
	6-8 mm	M12P-F04B-S-D8	163 004 521 3106
5	4-6 mm	M12P-F05B-S-D6	163 005 521 3103
	6-8 mm	M12P-F05B-S-D8	163 005 521 3104

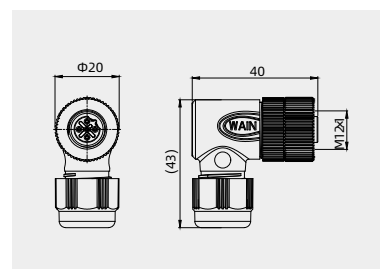

Female cable connector,  
metal locking system,  
screw clamp connection



Contacts	Cable outlet	Designation	Order No.
4	4-6 mm	M12-F04B-S-D6	163 004 521 1001
	6-8 mm	M12-F04B-S-D8	163 004 521 1002
5	4-6 mm	M12-F05B-S-D6	163 005 521 1001
	6-8 mm	M12-F05B-S-D8	163 005 521 1002

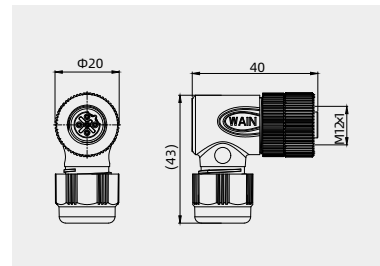

Female cable connector,  
stainless steel locking system,  
screw clamp connection,



Contacts	Cable outlet	Designation	Order No.
4	4-6 mm	M12S-F04B-S-D6	163 004 521 1003
	6-8 mm	M12S-F04B-S-D8	163 004 521 1004
5	4-6 mm	M12S-F05B-S-D6	163 005 521 1004
	6-8 mm	M12S-F05B-S-D8	163 005 521 1005

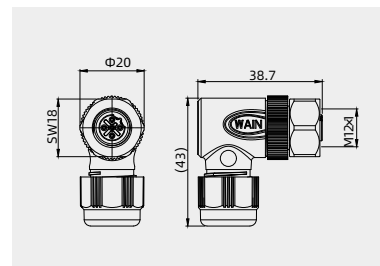

## M12-B Circular Connector

125/250V 4A



## Technical characteristics

	3-pole	4-pole	5-pole
Rated current(40°C )	4A	4A	4A
Rated voltage	250V	250V	125V
Rated impulse voltage	2500V	2500V	1500V
Pollution degree	3	3	3
Overvoltage categorie	II	II	II
Contact resistance	≤ 10 mΩ	≤ 10 mΩ	≤ 10 mΩ
Connector locking system	screw M12x1	screw M12x1	screw M12x1
Termination	solde terminal	solde terminal	solde terminal
Wire gauge	max.0.75mm <sup>2</sup> (max.AWG18)	max.0.75mm <sup>2</sup> (max.AWG18)	max.0.75mm <sup>2</sup> (max.AWG18)
Cable outlet	4-8mm	4-8mm	4-8mm
Degree of protection	IP67	IP67	IP67
Mechanical operation	> 100	> 100	> 100
Limiting temperature	-40°C ...+85°C	-40°C ...+85°C	-40°C ...+85°C
Material group	II	II	II
Contact material	copper alloy	copper alloy	copper alloy
Surface finishes	Au	Au	Au
Material of housing	PA/PBT/zinc alloy/copper alloy	PA/PBT/zinc alloy/copper alloy	PA/PBT/zinc alloy/copper alloy

## Angled cable connectors

Female cable connector,  
plastic locking system,  
solde terminal



B-Code



Contacts	Cable outlet	Designation	Order No.
3	4-6 mm	M12P-FST03B-S-D6	163 003 523 3506
	6-8 mm	M12P-FST03B-S-D8	163 003 523 3507
4	4-6 mm	M12P-FST04B-S-D6	163 004 523 3508
	6-8 mm	M12P-FST04B-S-D8	163 004 523 3509
5	4-6 mm	M12P-FST05B-S-D6	163 005 523 3508
	6-8 mm	M12P-FST05B-S-D8	163 005 523 3509

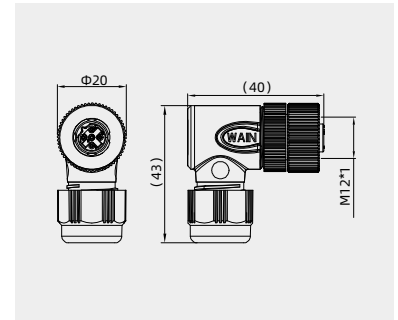

Female cable connector,  
metal locking system,  
solde terminal



B-Code



Contacts	Cable outlet	Designation	Order No.
3	4-6 mm	M12-FST03B-S-D6	163 003 523 3508
	6-8 mm	M12-FST03B-S-D8	163 003 523 3509
4	4-6 mm	M12-FST04B-S-D6	163 004 523 3510
	6-8 mm	M12-FST04B-S-D8	163 004 523 3511
5	4-6 mm	M12-FST05B-S-D6	163 005 523 3510
	6-8 mm	M12-FST05B-S-D8	163 005 523 3511

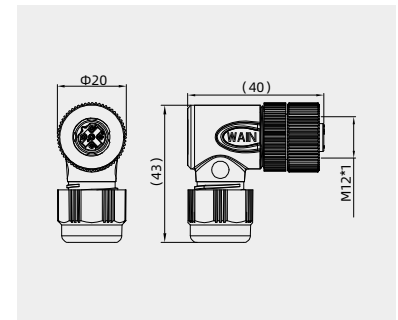

Female cable connector,  
stainless steel locking system,  
solde terminal



B-Code



Contacts	Cable outlet	Designation	Order No.
3	4-6 mm	M12S-FST03B-S-D6	163 003 523 3510
	6-8 mm	M12S-FST03B-S-D8	163 003 523 3511
4	4-6 mm	M12S-FST04B-S-D6	163 004 523 3512
	6-8 mm	M12S-FST04B-S-D8	163 004 523 3513
5	4-6 mm	M12S-FST05B-S-D6	163 005 523 3512
	6-8 mm	M12S-FST05B-S-D8	163 005 523 3513

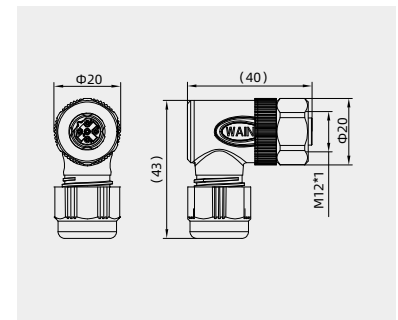

## M12-B Circular Connector

125/250V 2/8A

## Technical characteristics

	5-pole
Rated current(40°C )	Contacts:1-4 8A; Contacts:5 2A
Rated voltage	125V
Rated impulse voltage	1500V
Pollution degree	3
Overvoltage categorie	II
Contact resistance	≤ 10 mΩ
Connector locking system	screw M12x1
Termination	screw
Wire gauge	max.1.5mm <sup>2</sup> (max.AWG16)
Cable outlet	8-10mm
Degree of protection	IP67
Mechanical operation	> 100
Limiting temperature	-40°C ...+85°C
Material group	II
Material of contact	copper alloy
Contact plating	Au
Insulating material	PA
Material of housing	PA/PBT

## Angled cable connectors

Female cable connector,  
plastic locking system,  
screw clamp connection

Contacts	Cable outlet	Designation	Order No.
5	8-10 mm	M12P-F05B-S-D10	163 005 521 3105

B-Code



5pin

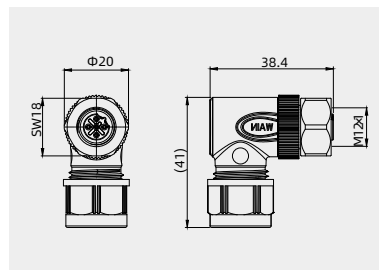

Female cable connector,  
metal locking system,  
screw clamp connection

Contacts	Cable outlet	Designation	Order No.
5	8-10 mm	M12-F05B-S-D10	163 005 521 1003

Recommended use

B-Code



5pin

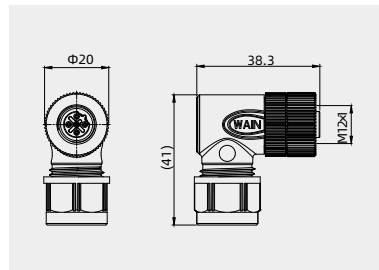

Female cable connector,  
stainless steel locking system,  
screw clamp connection,

Contacts	Cable outlet	Designation	Order No.
5	8-10 mm	M12S-F05B-S-D10	163 005 521 1006

B-Code



5pin

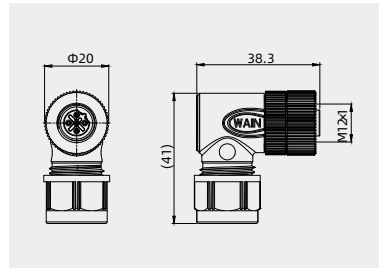

## M12-B Circular Connector

125/250V 4A

### Technical characteristics

	3-pole	4-pole	5-pole
Rated current(40°C )	4A	4A	4A
Rated voltage	250V	250V	125V
Rated impulse voltage	2500V	2500V	1500V
Pollution degree	3	3	3
Overvoltage categorie	II	II	II
Contact resistance	≤ 10 mΩ	≤ 10 mΩ	≤ 10 mΩ
Connector locking system	screw M12x1	screw M12x1	screw M12x1
Termination	solde terminal	screw terminal/solde terminal	screw terminal/solde terminal
Wire gauge	max.0.75mm <sup>2</sup> (max.AWG18)	max.0.75mm <sup>2</sup> (max.AWG18)	max.0.75mm <sup>2</sup> (max.AWG18)
Cable outlet	4-6,6-8mm	4-6,6-8mm	4-6,6-8mm
Degree of protection	IP67	IP67	IP67
Mechanical operation	> 100	> 100	> 100
Limiting temperature	-40°C ...+85°C	-40°C ...+85°C	-40°C ...+85°C
Material group	II	II	II
Material of contact	copper alloy	copper alloy	copper alloy
Contact plating	Au	Au	Au
Insulating material	PA	PA	PA
Material of housing	PA/PBT/zinc alloy/copper alloy	PA/PBT/zinc alloy/copper alloy	PA/PBT/zinc alloy/copper alloy

### Angled cable connectors, shielded

Female cable connector, shielded,  
screw clamp connection,  
with shielding ring



B-Code



Contacts	Cable outlet	Designation	Order No.
4	4-6 mm	M12-F04B-S-D6-SH	163 004 521 2003
	6-8 mm	M12-F04B-S-D8-SH	163 004 521 2004
5	4-6 mm	M12-F05B-S-D6-SH	163 005 521 2003
	6-8 mm	M12-F05B-S-D8-SH	163 005 521 2004

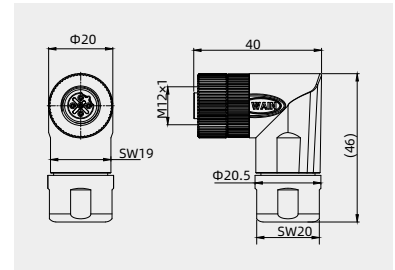

Female cable connector, shielded,  
solde terminal, with shielding ring



B-Code



Contacts	Cable outlet	Designation	Order No.
3	4-6 mm	M12-FST03B-S-D6-SH	163 003 523 3512
	6-8 mm	M12-FST03B-S-D8-SH	163 003 523 4500
4	4-6 mm	M12-FST04B-S-D6-SH	163 004 523 2502
	6-8 mm	M12-FST04B-S-D8-SH	163 004 523 2503
5	4-6 mm	M12-FST05B-S-D6-SH	163 005 523 2502
	6-8 mm	M12-FST05B-S-D8-SH	163 005 523 2503

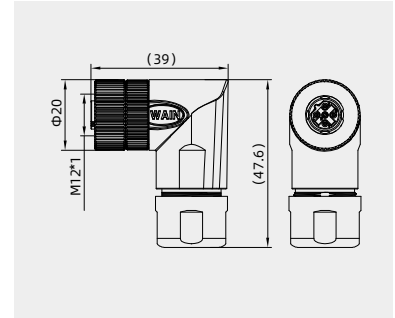



Assembly instruction

• Assembly instruction

- Strip length male/female cable connector, male/female angled connector, **not shielded**

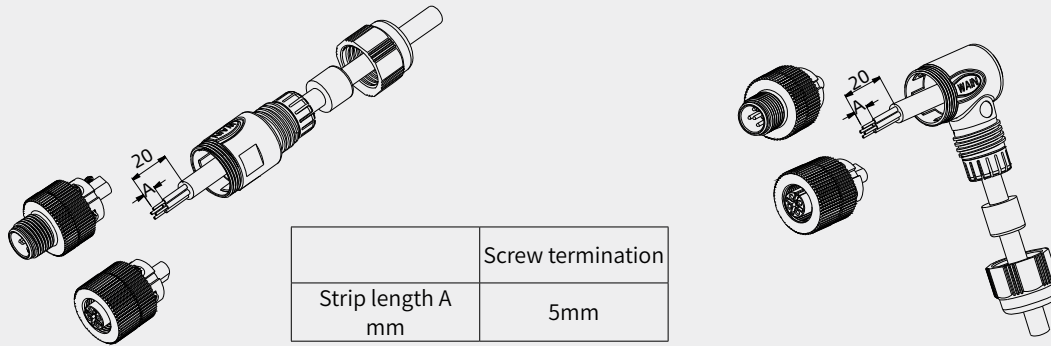

- Strip length male/female cable duo connector, male/female angled duo connector, **not shielded**

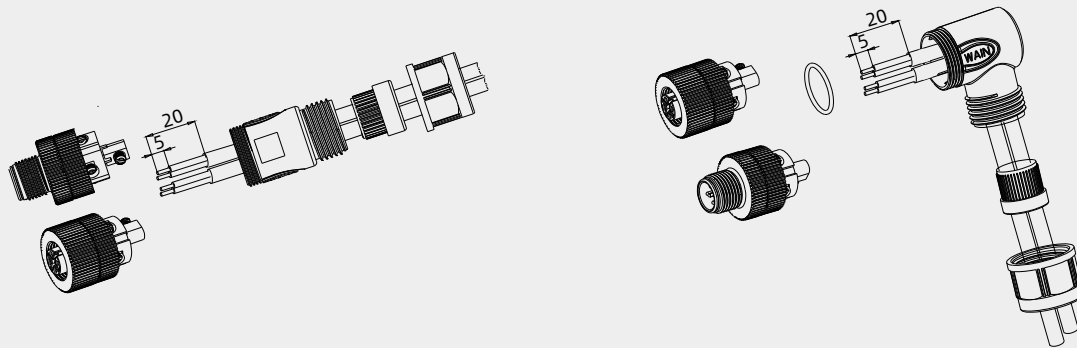

- Strip length male/female cable connector, **with shielding ring**

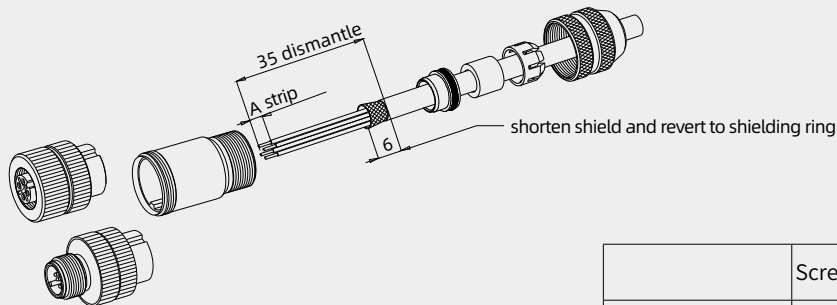

	Screw termination
Strip length A mm	5mm

## • Assembly instruction

- Stripping length of male/female angled cable connector , **with shielded ring.**

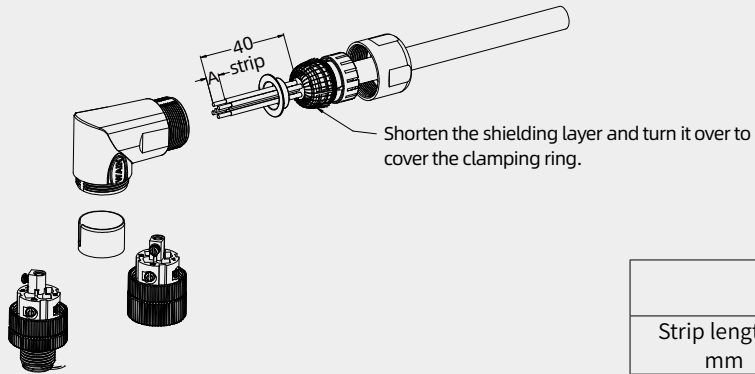

	Screw termination
Strip length A mm	5mm

• Component part drawing

- Cable connector **not shielded**

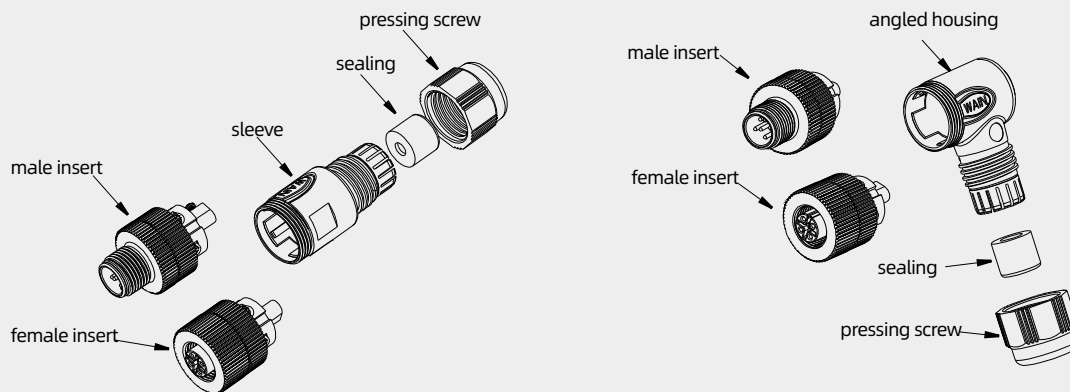

- Duo-cable connector screw termination, **not shielded**

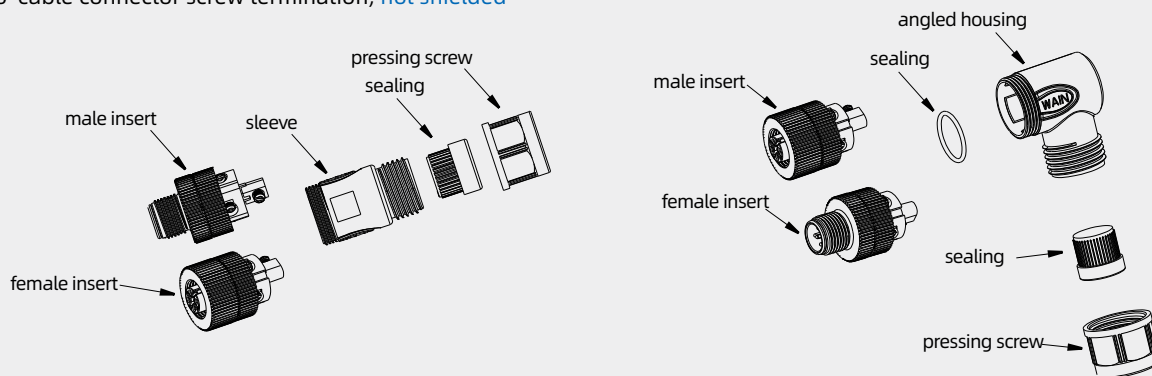

- Cable connector **with shielding ring**

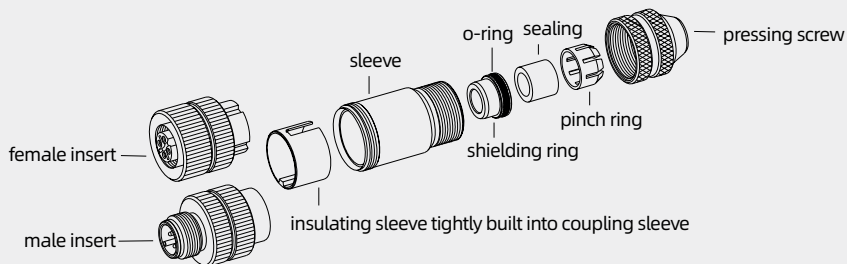

• Component part drawing

- Angled connector Screw termination, shielded

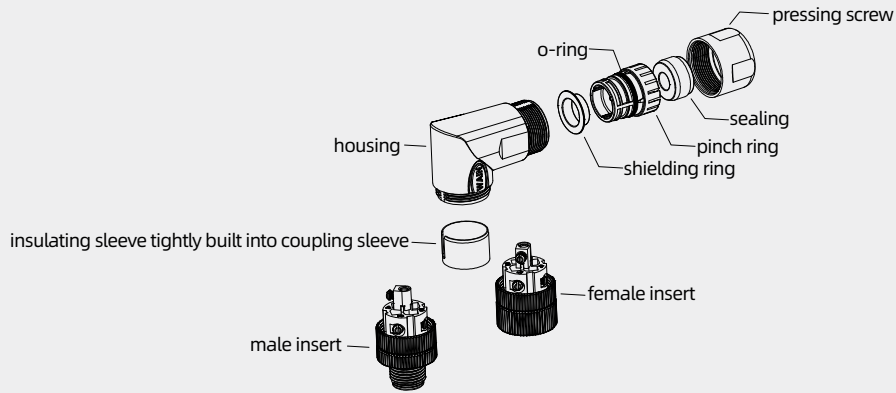

• Rating

- Attenuation curve according to DIN 47250-6
- For straight cable connectors, with shielding ring

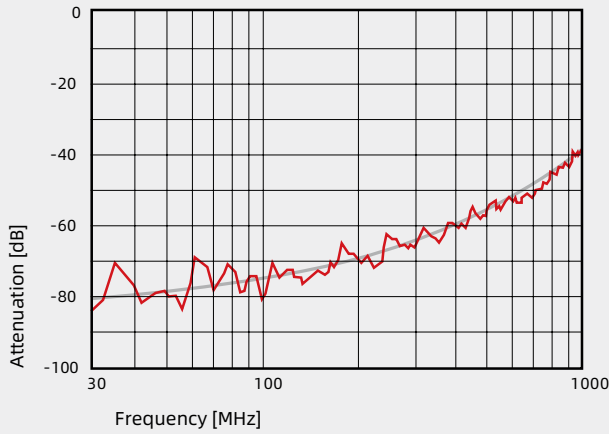

- Attenuation curve according to DIN 47250-6
- For straight cable connectors, with iris type spring

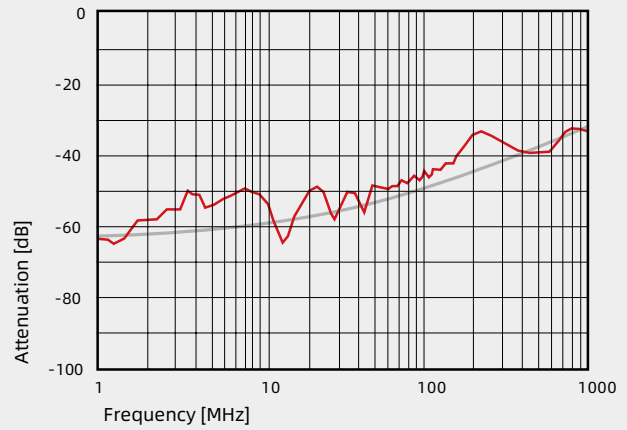

- Derating curve according to DIN EN 60512 for POWER cable connectors

- 4 pole version
- 5 pole version

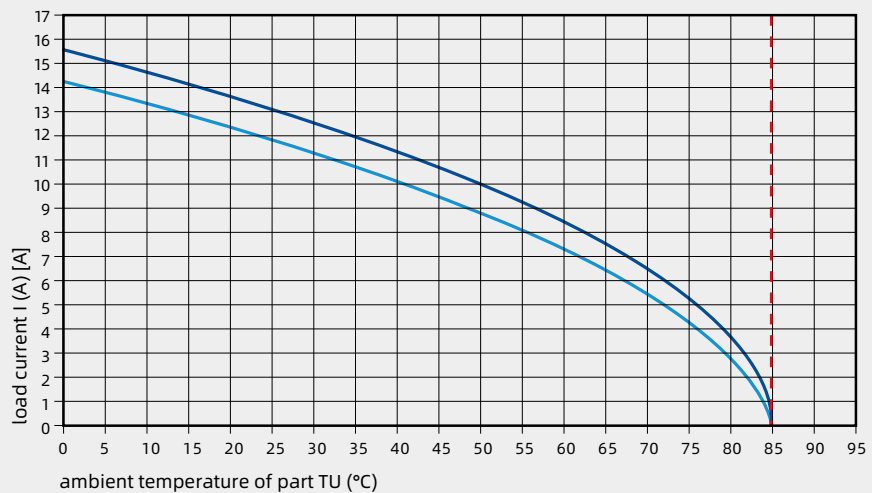

## M12-B Circular Connector

125/250V 4A

## Technical characteristics

	3-pole	4-pole	5-pole
Rated current(40°C )	4A	4A	4A
Rated voltage	250V	250V	125V
Rated impulse voltage	2500V	2500V	1500V
Pollution degree	3	3	3
Overvoltage categorie	II	II	II
Contact resistance	≤ 10 mΩ	≤ 10 mΩ	≤ 10 mΩ
Connector locking system	screw M12x1	screw M12x1	screw M12x1
Termination	crimp, moulded	crimp, moulded	crimp, moulded
Wire gauge	max.0.34mm <sup>2</sup> (AWG22)	max.0.34mm <sup>2</sup> (AWG22)	max.0.25mm <sup>2</sup> AWG24)
Cable outlet	-	-	-
Degree of protection	IP67 shielded	IP67 shielded	IP67 shielded
Mechanical operation	> 100	> 100	> 100
Limiting temperature	-25°C ...+85°C	-25°C ...+85°C	-25°C ...+85°C
Material group	II	II	II
Material of contact	copper alloy	copper alloy	copper alloy
Contact plating	Au	Au	Au
Insulating material	PA	PA	PA
Material of housing	TPU	TPU	TPU

## Straight cable connectors,cable

Male connector moulded,screw shielded

Recommended use



Contacts	Cable	Cable length	Designation	Order No.
3	3x0.34PVC	1.5 m	M12-M03B-T-1.5-PVC-SH	163 003 401 4045
		5.0 m	M12-M03B-T-5.0-PVC-SH	163 003 401 4046
	3x0.34PUR	1.5 m	M12-M03B-T-1.5-PUR-SH	163 003 401 4043
		5.0 m	M12-M03B-T-5.0-PUR-SH	163 003 401 4044
4	4x0.34PVC	1.5 m	M12-M04B-T-1.5-PVC-SH	163 004 401 4047
		5.0 m	M12-M04B-T-5.0-PVC-SH	163 004 401 4048
	4x0.34PUR	1.5 m	M12-M04B-T-1.5-PUR-SH	163 004 401 4045
		5.0 m	M12-M04B-T-5.0-PUR-SH	163 004 401 4046
5	5x0.25PVC	1.5 m	M12-M05B-T-1.5-PVC-SH	163 005 401 4043
		5.0 m	M12-M05B-T-5.0-PVC-SH	163 005 401 4044
	5x0.25PUR	1.5 m	M12-M05B-T-1.5-PUR-SH	163 005 401 4063
		5.0 m	M12-M05B-T-5.0-PUR-SH	163 005 401 4064

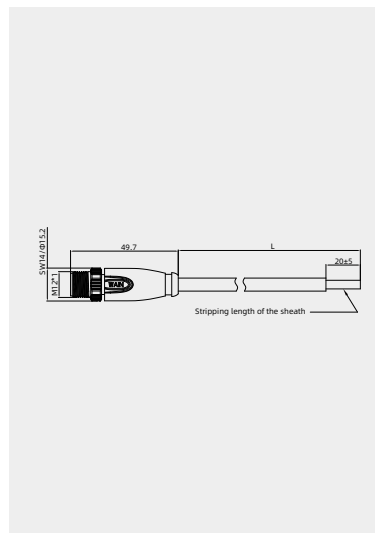

## B-Code



3pin

4pin

5pin

\*Further cable length upon request.

## M12-B Circular Connector

125/250V 4A

## Technical characteristics

	3-pole	4-pole	5-pole
Rated current(40°C )	4A	4A	4A
Rated voltage	250V	250V	125V
Rated impulse voltage	2500V	2500V	1500V
Pollution degree	3	3	3
Overvoltage categorie	II	II	II
Contact resistance	≤ 10 mΩ	≤ 10 mΩ	≤ 10 mΩ
Connector locking system	screw M12x1	screw M12x1	screw M12x1
Termination	crimp, moulded	crimp, moulded	crimp, moulded
Wire gauge	max.0.34mm <sup>2</sup> (AWG22)	max.0.34mm <sup>2</sup> (AWG22)	max.0.25mm <sup>2</sup> AWG24)
Cable outlet	-	-	-
Degree of protection	IP67 shielded	IP67 shielded	IP67 shielded
Mechanical operation	> 100	> 100	> 100
Limiting temperature	-25°C ...+85°C	-25°C ...+85°C	-25°C ...+85°C
Material group	II	II	II
Material of contact	copper alloy	copper alloy	copper alloy
Contact plating	Au	Au	Au
Insulating material	PA	PA	PA
Material of housing	TPU	TPU	TPU

## Straight cable connectors,cable

Female connector moulded,screw shielded

Recommended use



Contacts	Cable	Cable length	Designation	Order No.
3	3x0.34PVC	1.5 m	M12-F03B-T-1.5-PVC-SH	163 003 402 4046
		5.0 m	M12-F03B-T-5.0-PVC-SH	163 003 402 4047
	3x0.34PUR	1.5 m	M12-F03B-T-1.5-PUR-SH	163 003 402 4043
		5.0 m	M12-F03B-T-5.0-PUR-SH	163 003 402 4044
4	4x0.34PVC	1.5 m	M12-F04B-T-1.5-PVC-SH	163 004 402 4046
		5.0 m	M12-F04B-T-5.0-PVC-SH	163 004 402 4047
	4x0.34PUR	1.5 m	M12-F04B-T-1.5-PUR-SH	163 004 402 4045
		5.0 m	M12-F04B-T-5.0-PUR-SH	163 004 402 4044
5	5x0.25PVC	1.5 m	M12-F05B-T-1.5-PVC-SH	163 005 402 4046
		5.0 m	M12-F05B-T-5.0-PVC-SH	163 005 402 4044
	5x0.25PUR	1.5 m	M12-F05B-T-1.5-PUR-SH	163 005 402 4064
		5.0 m	M12-F05B-T-5.0-PUR-SH	163 005 402 4065

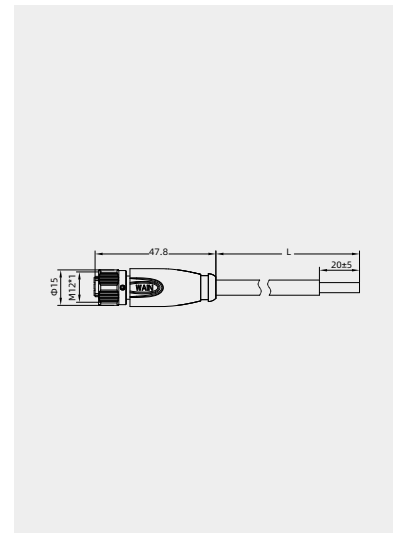

## B-Code



•Further cable length upon request.

## M12-B Circular Connector

250V 4A

## Technical characteristics

	2-pole
Rated current(40°C )	4A
Rated voltage	250V
Rated impulse voltage	2500V
Pollution degree	3
Overvoltage categorie	II
Contact resistance	≤ 10 mΩ
Connector locking system	screw M12x1
Termination	crimp, moulded
Wire gauge	max.0.34mm <sup>2</sup> (AWG22)
Cable outlet	-
Degree of protection	IP67 shielded
Mechanical operation	> 100
Limiting temperature	-25°C ...+85°C
Material group	II
Material of contact	copper alloy
Contact plating	Au
Insulating material	PA
Material of housing	TPU

## Straight cable connectors,cable

Male connector moulded,screw shielded

Recommended use

Contacts	Cable	Cable length	Designation	Order No.
2	2x0.25PVC	1.5 m	M12-M02B-T-1.5-PVC-DP	163 002 401 4005
		5.0 m	M12-M02B-T-5.0-PVC-DP	163 002 401 4007
	2x0.25PUR	1.5 m	M12-M02B-T-1.5-PUR-DP	163 002 401 4006
		5.0 m	M12-M02B-T-5.0-PUR-DP	163 002 401 4008



B-Code

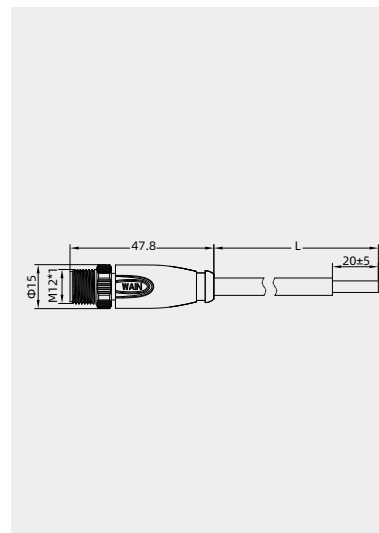

M12-B

•Further cable length upon request.

## M12-B Circular Connector

250V 4A

## Technical characteristics

	2-pole
Rated current(40°C )	4A
Rated voltage	250V
Rated impulse voltage	2500V
Pollution degree	3
Overvoltage categorie	II
Contact resistance	≤ 10 mΩ
Connector locking system	screw M12x1
Termination	crimp, moulded
Wire gauge	max.0.34mm <sup>2</sup> (AWG22)
Cable outlet	-
Degree of protection	IP67 shielded
Mechanical operation	> 100
Limiting temperature	-25°C ...+85°C
Material group	II
Material of contact	copper alloy
Contact plating	Au
Insulating material	PA
Material of housing	TPU

## Straight cable connectors,cable

Female connector moulded,screw shielded

Recommended use

Contacts	Cable	Cable length	Designation	Order No.
2	2x0.25PVC	1.5 m	M12-F02B-T-1.5-PVC-DP	163 002 402 4001
		5.0 m	M12-F02B-T-5.0-PVC-DP	163 002 402 4003
	2x0.25PUR	1.5 m	M12-F02B-T-1.5-PUR-DP	163 002 402 4002
		5.0 m	M12-F02B-T-5.0-PUR-DP	163 002 402 4004

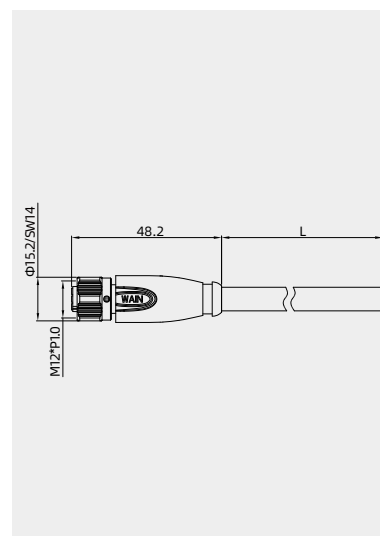

M12-B

B-Code



•Further cable length upon request.

18B-19.2 WAIN ELECTRICAL



## M12-B Circular Connector

125/250V 4A

## Technical characteristics

	4-pole	5-pole
Rated current(40°C )	4A	4A
Rated voltage	250V	125V
Rated impulse voltage	2500V	1500V
Pollution degree	3	3
Overvoltage categorie	II	II
Contact resistance	≤ 10 mΩ	≤ 10 mΩ
Connector locking system	screw M12x1	screw M12x1
Termination	single-strand wires	single-strand wires
Wire gauge	max.0.75mm <sup>2</sup> (AWG18)	max.0.75mm <sup>2</sup> (AWG18)
Cable outlet	-	-
Degree of protection	IP67	IP67
Mechanical operation	> 100	> 100
Limiting temperature	-40°C ...+85°C	-40°C ...+85°C
Material group	II	II
Material of contact	copper alloy	copper alloy
Contact plating	Au	Au
Insulating material	PA	PA
Material of housing	zinc diecasting nickel plated	zinc diecasting nickel plated

## Socket

Male panel mount connector  
with single wires, 0.25mm<sup>2</sup>  
length 0.2m

Recommended use



B-Code



4pin 5pin

Contacts	Thread	Designation	Order No.
4	PG9	M12-M04B-BK-PG9-W0.25	163 004 301 4004
	M16x1.5	M12-M04B-BK-M16-W0.25	163 004 301 4005
5	PG9	M12-M05B-BK-PG9-W0.25	163 005 301 4002
	M16x1.5	M12-M05B-BK-M16-W0.25	163 005 301 4003

Customized cable length upon request

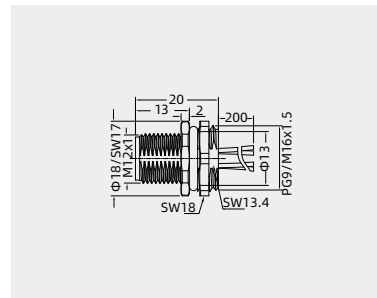

Male panel mount connector, solder

Recommended use



B-Code



4pin 5pin

Contacts	Thread	Designation	Order No.
4	PG9	M12-M04B-BK-PG9-C	163 004 313 1002
	M16x1.5	M12-M04B-BK-M16-C	163 004 313 1003
5	PG9	M12-M05B-BK-PG9-C	163 005 313 1002
	M16x1.5	M12-M05B-BK-M16-C	163 005 313 1003

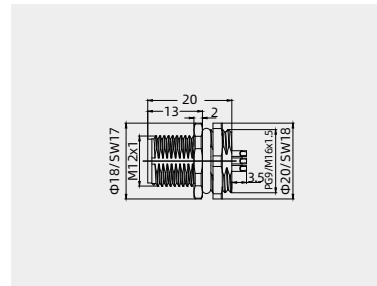

Male panel mount connector, dip solder



B-Code



4pin 5pin

Contacts	Thread	Designation	Order No.
4	PG9	M12-M04B-BK-PG9-D	163 004 314 1003
	M16x1.5	M12-M04B-BK-M16-D	163 004 314 1004
5	PG9	M12-M05B-BK-PG9-D	163 005 314 1003
	M16x1.5	M12-M05B-BK-M16-D	163 005 314 1004

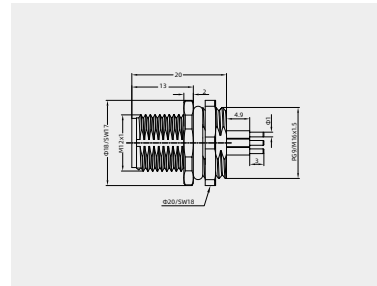

## M12-B Circular Connector

125/250V 4A

## Technical characteristics

	4-pole	5-pole
Rated current(40°C )	4A	4A
Rated voltage	250V	125V
Rated impulse voltage	2500V	1500V
Pollution degree	3	3
Overvoltage categorie	II	II
Contact resistance	≤ 10 mΩ	≤ 10 mΩ
Connector locking system	screw M12x1	screw M12x1
Termination	single-strand wires	single-strand wires
Wire gauge	max.0.75mm <sup>2</sup> (AWG18)	max.0.75mm <sup>2</sup> (AWG18)
Cable outlet	-	-
Degree of protection	IP67	IP67
Mechanical operation	> 100	> 100
Limiting temperature	-40°C ...+85°C	-40°C ...+85°C
Material group	II	II
Material of contact	copper alloy	copper alloy
Contact plating	Au	Au
Insulating material	PA	PA
Material of housing	zinc diecasting nickel plated	zinc diecasting nickel plated

## Socket

## Male panel mount connector

with single wires, 0,25mm<sup>2</sup>

length 0.2m, front fastened

Recommended use



B-Code



4pin

5pin

Contacts	Thread	Designation	Order No.
4	PG9	M12-M04B-BKR-PG9-W0.25	163 004 301 4012
	M16x1.5	M12-M04B-BKR-M16-W0.25	163 004 301 4015
5	PG9	M12-M05B-BKR-PG9-W0.25	163 005 301 4012
	M16x1.5	M12-M05B-BKR-M16-W0.25	163 005 301 4013

Customized cable length upon request

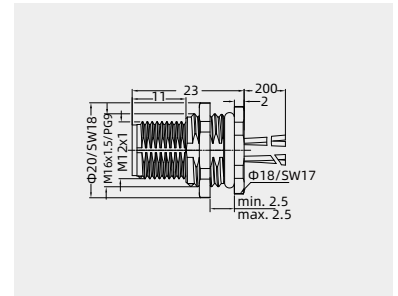

## Male panel mount connector,

front fastened, dip solder



B-Code



4pin

5pin

Contacts	Thread	Designation	Order No.
4	PG9	M12-M04B-BKR-PG9-D	163 004 314 1012
	M16x1.5	M12-M04B-BKR-M16-D	163 004 314 1013
5	PG9	M12-M05B-BKR-PG9-D	163 005 314 1012
	M16x1.5	M12-M05B-BKR-M16-D	163 005 314 1013

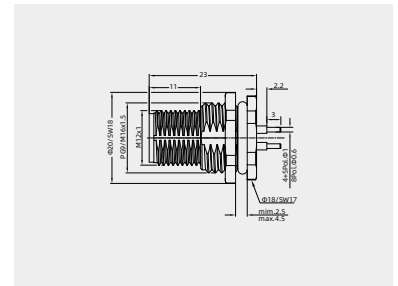

## M12-B Circular Connector

125/250V 4A

## Technical characteristics

	4-pole	5-pole
Rated current(40°C )	4A	4A
Rated voltage	250V	125V
Rated impulse voltage	2500V	1500V
Pollution degree	3	3
Overvoltage categorie	II	II
Contact resistance	≤ 10 mΩ	≤ 10 mΩ
Connector locking system	Thread	Thread
Termination	solder,single-strand wires	solder,single-strand wires
Wire gauge	max.0.75mm <sup>2</sup> (AWG18)	max.0.75mm <sup>2</sup> (AWG18)
Cable outlet	-	-
Degree of protection	IP67	IP67
Mechanical operation	> 100	> 100
Limiting temperature	-40°C ...+85°C	-40°C ...+85°C
Material group	II	II
Material of contact	copper alloy	copper alloy
Contact plating	Au	Au
Insulating material	PA	PA
Material of housing	zinc diecasting nickel plated	zinc diecasting nickel plated

## Socket

Female panel mount connector  
with single wires, /0.25mm<sup>2</sup>/length  
0.2m



B-Code



4pin 5pin

Contacts	Thread	Designation	Order No.
4	PG9	M12-F04B-BK-PG9-W0.25	163 004 302 4003
	M16x1.5	M12-F04B-BK-M16-W0.25	163 004 302 4004
5	PG9	M12-F05B-BK-PG9-W0.25	163 005 302 4007
	M16x1.5	M12-F05B-BK-M16-W0.25	163 005 302 4008

Customized cable length upon request

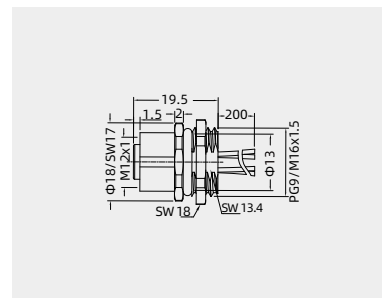

Female panel mount connector, solder  
PG9/M16x1.5



B-Code



4pin 5pin

Contacts	Thread	Designation	Order No.
4	PG9	M12-F04B-BK-PG9-C	163 004 323 1002
	M16x1.5	M12-F04B-BK-M16-C	163 004 323 1003
5	PG9	M12-F05B-BK-PG9-C	163 005 323 1002
	M16x1.5	M12-F05B-BK-M16-C	163 005 323 1003

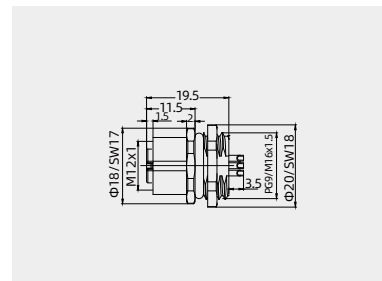

Female panel mount connector,  
dip solder



B-Code



4pin 5pin

Contacts	Thread	Designation	Order No.
4	PG9	M12-F04B-BK-PG9-D	163 004 324 1003
	M16x1.5	M12-F04B-BK-M16-D	163 004 324 1004
5	PG9	M12-F05B-BK-PG9-D	163 005 324 1003
	M16x1.5	M12-F05B-BK-M16-D	163 005 324 1004

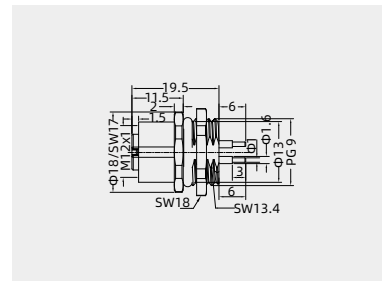

## M12-B Circular Connector

125/250V 4A

## Technical characteristics

	4-pole	5-pole
Rated current(40°C)	4A	4A
Rated voltage	250V	125V
Rated impulse voltage	2500V	1500V
Pollution degree	3	3
Overvoltage categorie	II	II
Contact resistance	≤ 10 mΩ	≤ 10 mΩ
Connector locking system	Thread	Thread
Termination	solder,single-strand wires	solder,single-strand wires
Wire gauge	max.0.75mm <sup>2</sup> (AWG18)	max.0.75mm <sup>2</sup> (AWG18)
Cable outlet	-	-
Degree of protection	IP67	IP67
Mechanical operation	> 100	> 100
Limiting temperature	-40°C ...+85°C	-40°C ...+85°C
Material group	II	II
Material of contact	copper alloy	copper alloy
Contact plating	Au	Au
Insulating material	PA	PA
Material of housing	zinc diecasting nickel plated	zinc diecasting nickel plated

## Socket

Female panel mount connector,  
front fastened, with single wires,  
0.25mm<sup>2</sup>/length 0.2m



B-Code



Contacts	Thread	Designation	Order No.
4	PG9	M12-F04B-BKR-PG9-W0.25	163 004 302 4517
	M16x1.5	M12-F04B-BKR-M16-W0.25	163 004 302 4518
5	PG9	M12-F05B-BKR-PG9-W0.25	163 005 302 4512
	M16x1.5	M12-F05B-BKR-M16-W0.25	163 005 302 4513

Customized cable length upon request

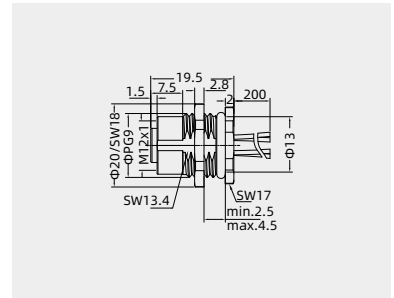

Female panel mount connector,  
solder, front fastened



B-Code



Contacts	Thread	Designation	Order No.
4	PG9	M12-F04B-BKR-PG9-C	163 004 323 1012
	M16x1.5	M12-F04B-BKR-M16-C	163 004 323 1013
5	PG9	M12-F05B-BKR-PG9-C	163 005 323 1012
	M16x1.5	M12-F05B-BKR-M16-C	163 005 323 1013

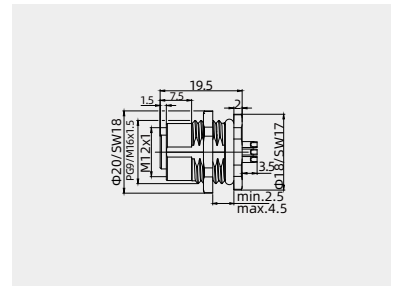

Female panel mount connector,  
dip solder, front fastened



B-Code



Contacts	Thread	Designation	Order No.
4	PG9	M12-F04B-BKR-PG9-D	163 004 324 1012
	M16x1.5	M12-F04B-BKR-M16-D	163 004 324 1013
5	PG9	M12-F05B-BKR-PG9-D	163 005 324 1012
	M16x1.5	M12-F05B-BKR-M16-D	163 005 324 1013

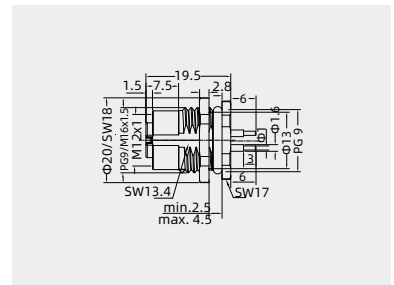

Accessories

Protection covers IP67

Protection cover  
for male cable connector



Description	Designation	Order No.
Without cord	M12-MCV	163 000 001 9003
With cord	M12-MCV/1	163 000 001 9001

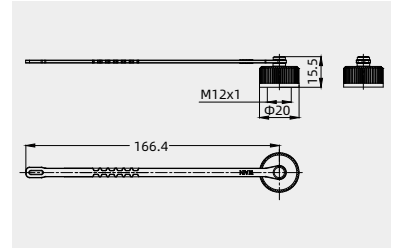

Protection cover  
for female cable connector



Description	Designation	Order No.
Without cord	M12-FCV	163 000 002 9003
With cord	M12-FCV/1	163 000 002 9001

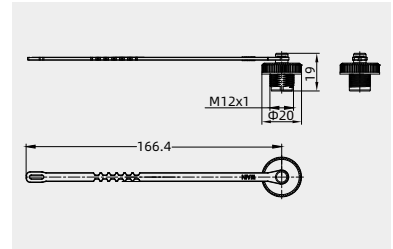

Protection covers, for flange  
mount panel



Description	Designation	Order No.
Dust-proof	M12-WNPP-M16/BK	163 000 000 9001

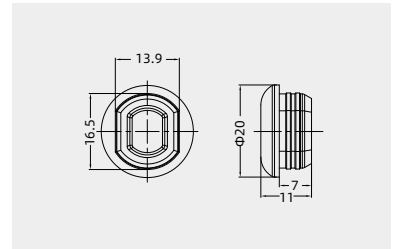

• Contact arrangements

• Male insert (mating side)

• Female insert (mating side)

2 contacts

2 contacts

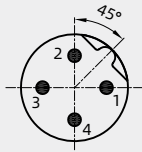

	X	Y	
1			1. n.C
2	0.00	2.50	2. green
3			3. n.C
4	0.00	-2.50	4. red



	X	Y	
1			1. n.C
2	0.00	2.50	2. green
3			3. n.C
4	0.00	-2.50	4. red

3 contacts

3 contacts

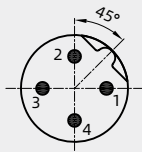

	X	Y	
1	2.50	0.00	1. brown
2			2. n.C
3	-2.50	0.00	3. blue
4	0.00	-2.50	4. black



	X	Y	
1	-2.50	0.00	1. brown
2			2. n.C
3	2.50	0.00	3. blue
4	0.00	-2.50	4. black

4 contacts

4 contacts

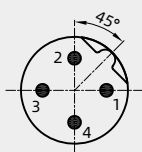

	X	Y	
1	2.50	0.00	1. brown
2	0.00	2.50	2. white
3	-2.50	0.00	3. blue
4	0.00	-2.50	4. black



	X	Y	
1	-2.50	0.00	1. brown
2	0.00	2.50	2. white
3	2.50	0.00	3. blue
4	0.00	-2.50	4. black

5 contacts

5 contacts

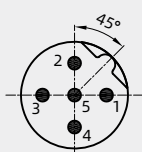

	X	Y	
1	2.50	0.00	1. brown
2	0.00	2.50	2. white
3	-2.50	0.00	3. blue
4	0.00	-2.50	4. black
5	0.00	0.00	5. grey



	X	Y	
1	-2.50	0.00	1. brown
2	0.00	2.50	2. white
3	2.50	0.00	3. blue
4	0.00	-2.50	4. black
5	0.00	0.00	5. grey

- Panel cut out

- Opening hole drawing male insert(PCB),  
Panel mount connectors

4 contacts

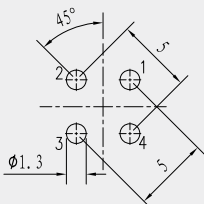

- Opening hole drawing female insert(PCB),  
Panel mount connectors

4 contacts

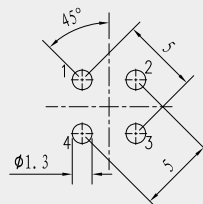

5 contacts

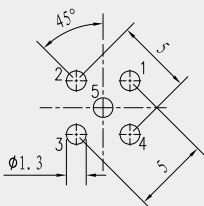

5 contacts

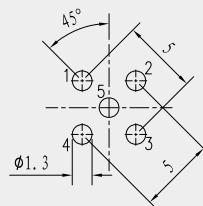

• Panel cut out

• Panel mount connectors

• Through-hole mounting

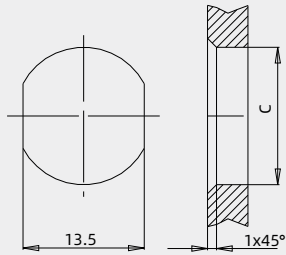

• Screw mounting

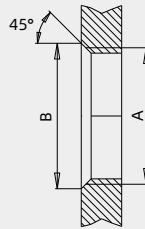

	A	B	C
PG9	PG9	16.2	15.3
PG13.5	PG13.5	21.5	20.5
M16x1.5	M16x1.5	17.0	16.1
M20x1.5	M20x1.5	21.0	20.1

Tightening torque according to  
DIN VDE 0619

Metal housing 6,25 Nm  
Plastic housing 3,75 Nm

• Panel mount connectors

• Rear panel mounting,  
front tighten

• Through-hole mounting

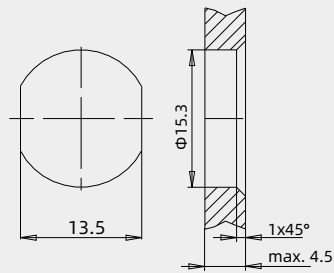

• Panel mount connectors  
front tighten

• Through-hole mounting

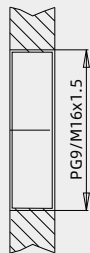

Tightening torque 6,25 Nm





M12-B

## M12 Circular Connector,D-coded



- Cable Connector
- Shielded / unshielded series
- Installable series and cast cable series
- Thread locking M12X1
- Screw terminal
- Shielding ring and ring spring shielding connection
- Cable length 1.5m and 5m
- Other cable length upon request, minimum order quantity 200 pieces
- Cable material can be customized according to requirements
- Protection grade IP67
- Anti-loose spring with nut

## M12-D Circular Connector

250V 4A

## Technical characteristics

Number of contacts	3-pole	4-pole	5-pole
Rated current(40°C )	4A	4A	4A
Rated voltage	250V	250V	125V
Rated impulse voltage	2500V	2500V	1500V
Pollution degree	3	3	3
Overvoltage categorie	II	II	II
Contact resistance	≤ 10 mΩ	≤ 10 mΩ	≤ 10 mΩ
Connector locking system	screw M12x1	screw M12x1	screw M12x1
Termination	Solder terminal	Solder terminal	Solder terminal
Wire gauge	max.0.75mm <sup>2</sup> (max.AWG18)	max.0.75mm <sup>2</sup> (max.AWG18)	max.0.75mm <sup>2</sup> (max.AWG18)
Cable outlet	4-8mm	4-8mm	4-8mm
Degree of protection	IP67	IP67	IP67
Mechanical operation	> 100	> 100	> 100
Limiting temperature	-40°C ...+85°C	-40°C ...+85°C	-40°C ...+85°C
Material group	II	II	II
Material of contact	copper alloy	copper alloy	copper alloy
Contact plating	Au	Au	Au
Insulating material	PA	PA	PA
Material of housing	PA/PBT/zinc alloy/copper alloy	PA/PBT/zinc alloy/copper alloy	PA/PBT/zinc alloy/copper alloy

## Straight cable connectors



Male cable connector,plastic locking system, solder



D-Code



Contacts	Cable outlet	Designation	Order No.
3	4-6 mm	M12P-MST03D-T-D6	163 003 413 3514
	6-8 mm	M12P-MST03D-T-D8	163 003 413 3515
4	4-6 mm	M12P-MST04D-T-D6	163 004 413 3521
	6-8 mm	M12P-MST04D-T-D8	163 004 413 3522
5	4-6 mm	M12P-MST05D-T-D6	163 005 413 3521
	6-8 mm	M12P-MST05D-T-D8	163 005 413 3522

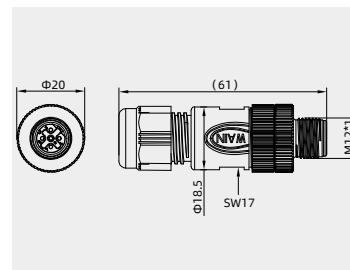

Male cable connector,metal locking system, solder



D-Code



Contacts	Cable outlet	Designation	Order No.
3	4-6 mm	M12-MST03D-T-D6	163 003 413 3516
	6-8 mm	M12-MST03D-T-D8	163 003 413 3517
4	4-6 mm	M12-MST04D-T-D6	163 004 413 3523
	6-8 mm	M12-MST04D-T-D8	163 004 413 3524
5	4-6 mm	M12-MST05D-T-D6	163 005 413 3523
	6-8 mm	M12-MST05D-T-D8	163 005 413 3520

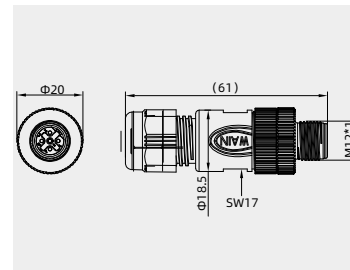

Male cable connector,stainless steel locking system, solder



D-Code



Contacts	Cable outlet	Designation	Order No.
3	4-6 mm	M12S-MST03D-T-D6	163 003 413 3518
	6-8 mm	M12S-MST03D-T-D8	163 003 413 3519
4	4-6 mm	M12S-MST04D-T-D6	163 004 413 3525
	6-8 mm	M12S-MST04D-T-D8	163 004 413 3526
5	4-6 mm	M12S-MST05D-T-D6	163 005 413 3524
	6-8 mm	M12S-MST05D-T-D8	163 005 413 3525

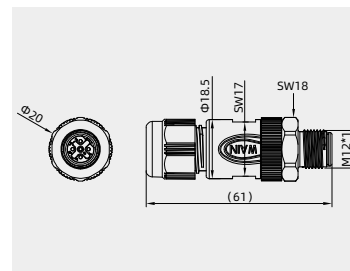

## M12-D Circular Connector

250V 4A

## Technical characteristics

Number of contacts	4-pole	5-pole
Rated current(40°C )	4A	4A
Rated voltage	250V	125V
Rated impulse voltage	2500V	1500V
Pollution degree	3	3
Overvoltage categorie	II	II
Contact resistance	≤ 10 mΩ	≤ 10 mΩ
Connector locking system	screw M12x1	screw M12x1
Termination	Solder terminal	Solder terminal
Wire gauge	max.0.75mm <sup>2</sup> (max.AWG18)	max.0.75mm <sup>2</sup> (max.AWG18)
Cable outlet	8-10mm	8-10mm
Degree of protection	IP67	IP67
Mechanical operation	> 100	> 100
Limiting temperature	-40°C ...+85°C	-40°C ...+85°C
Material group	II	II
Material of contact	copper alloy	copper alloy
Contact plating	Au	Au
Insulating material	PA	PA
Material of housing	PA/PBT/zinc alloy/copper alloy	PA/PBT/zinc alloy/copper alloy

## Straight cable connectors



Male cable connector, metal locking system, solder



D-Code



4pin

5pin

Contacts	Cable outlet	Designation	Order No.
4	8-10 mm	M12-MST04D-T-D10	163 004 413 3527
5	8-10 mm	M12-MST05D-T-D10	163 005 413 3526

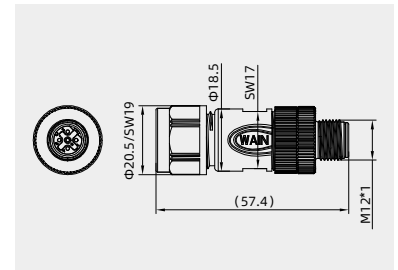

## M12-D Circular Connector

250V 4A

## Technical characteristics

Number of contacts	3-pole	4-pole	5-pole
Rated current(40°C )	4A	4A	4A
Rated voltage	250V	250V	125V
Rated impulse voltage	2500V	2500V	1500V
Pollution degree	3	3	3
Overvoltage categorie	II	II	II
Contact resistance	≤ 10 mΩ	≤ 10 mΩ	≤ 10 mΩ
Connector locking system	screw M12x1	screw M12x1	screw M12x1
Termination	Solder terminal	Solder terminal	Solder terminal
Wire gauge	max.0.75mm <sup>2</sup> (max.AWG18)	max.0.75mm <sup>2</sup> (max.AWG18)	max.0.75mm <sup>2</sup> (max.AWG18)
Cable outlet	4-8mm	4-8mm	4-8mm
Degree of protection	IP67	IP67	IP67
Mechanical operation	> 100	> 100	> 100
Limiting temperature	-40°C ...+85°C	-40°C ...+85°C	-40°C ...+85°C
Material group	II	II	II
Material of contact	copper alloy	copper alloy	copper alloy
Contact plating	Au	Au	Au
Insulating material	PA	PA	PA
Material of housing	PA/PBT/zinc alloy/copper alloy	PA/PBT/zinc alloy/copper alloy	PA/PBT/zinc alloy/copper alloy

## Angled cable connectors

Male cable connector,plastic  
locking system, solder

D-Code

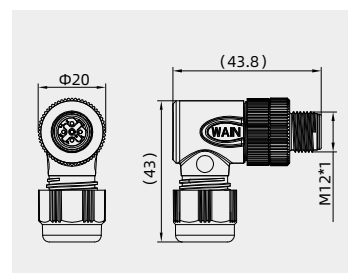

Contacts	Cable outlet	Designation	Order No.
3	4-6 mm	M12P-MST03D-S-D6	163 003 513 3512
	6-8 mm	M12P-MST03D-S-D8	163 003 513 3513
4	4-6 mm	M12P-MST04D-S-D6	163 004 513 3516
	6-8 mm	M12P-MST04D-S-D8	163 004 513 3517
5	4-6 mm	M12P-MST05D-S-D6	163 005 513 3517
	6-8 mm	M12P-MST05D-S-D8	163 005 513 3518

Male cable connector,metal  
locking system, solder

D-Code

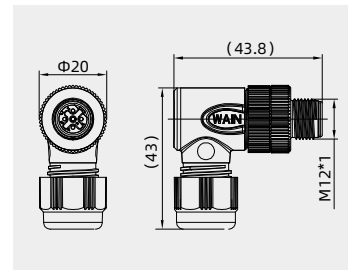

Contacts	Cable outlet	Designation	Order No.
3	4-6 mm	M12-MST03D-S-D6	163 003 513 3514
	6-8 mm	M12-MST03D-S-D8	163 003 513 3515
4	4-6 mm	M12-MST04D-S-D6	163 004 513 3518
	6-8 mm	M12-MST04D-S-D8	163 004 513 3519
5	4-6 mm	M12-MST05D-S-D6	163 005 513 3519
	6-8 mm	M12-MST05D-S-D8	163 005 513 3520

Male cable connector,stainless  
steel locking system, solder

D-Code

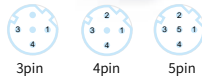

Contacts	Cable outlet	Designation	Order No.
3	4-6 mm	M12S-MST03D-S-D6	163 003 513 3516
	6-8 mm	M12S-MST03D-S-D8	163 003 513 3517
4	4-6 mm	M12S-MST04D-S-D6	163 004 513 3520
	6-8 mm	M12S-MST04D-S-D8	163 004 513 3521
5	4-6 mm	M12S-MST05D-S-D6	163 005 513 3521
	6-8 mm	M12S-MST05D-S-D8	163 005 513 3522

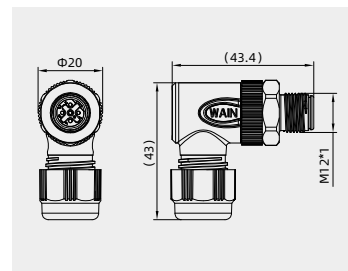

## M12-D Circular Connector

250V 4A

## Technical characteristics

Number of contacts	3-pole	4-pole	5-pole
Rated current(40°C )	4A	4A	4A
Rated voltage	250V	250V	125V
Rated impulse voltage	2500V	2500V	1500V
Pollution degree	3	3	3
Overvoltage categorie	II	II	II
Contact resistance	≤ 10 mΩ	≤ 10 mΩ	≤ 10 mΩ
Connector locking system	screw M12x1	screw M12x1	screw M12x1
Termination	Solder terminal	Solder terminal	Solder terminal
Wire gauge	max.0.75mm <sup>2</sup> (max.AWG18)	max.0.75mm <sup>2</sup> (max.AWG18)	max.0.75mm <sup>2</sup> (max.AWG18)
Cable outlet	4-8mm	4-8mm	4-8mm
Degree of protection	IP67	IP67	IP67
Mechanical operation	> 100	> 100	> 100
Limiting temperature	-40°C ...+85°C	-40°C ...+85°C	-40°C ...+85°C
Material group	II	II	II
Material of contact	copper alloy	copper alloy	copper alloy
Contact plating	Au	Au	Au
Insulating material	PA	PA	PA
Material of housing	PA/PBT/zinc alloy/copper alloy	PA/PBT/zinc alloy/copper alloy	PA/PBT/zinc alloy/copper alloy

## Angled cable connectors



Male cable connector, metal locking system, solder



D-Code



Contacts	Cable outlet	Designation	Order No.
3	4-6 mm	M12-MST03D-S-D6-SH	163 003 513 2504
	6-8 mm	M12-MST03D-S-D8-SH	163 003 513 2505
4	4-6 mm	M12-MST04D-S-D6-SH	163 004 513 2504
	6-8 mm	M12-MST04D-S-D8-SH	163 004 513 2505
5	4-6 mm	M12-MST05D-S-D6-SH	163 005 513 2503
	6-8 mm	M12-MST05D-S-D8-SH	163 005 513 2504

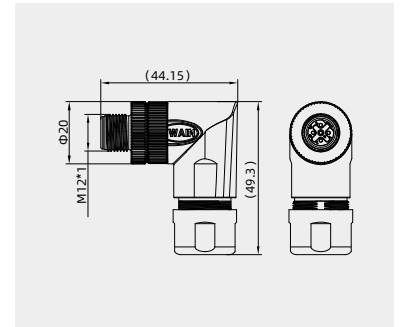

## M12-D Circular Connector

250V 4A

## Technical characteristics

Number of contacts	4
Rated current (40°C)	4A
Rated voltage	250V
Rated impulse voltage	2500V
Pollution degree	3
Overvoltage categorie	II
Contact resistance	≤ 10 mΩ
Connector locking system	screw M12x1
Termination	screw, <b>crimp</b>
Wire gauge	max.0.75mm <sup>2</sup> (max.AWG18), max.0.82mm <sup>2</sup> (max.AWG18)
Cable outlet	4-6mm,6-8mm
Degree of protection	IP67
Mechanical operation	> 100
Limiting temperature	-40°C ...+85°C
Material group	II
Material of contact	copper alloy
Contact plating	Au
Insulating material	PA
Material of housing	zinc diecasting nickel plated

## Straight cable connectors, shielded

Male cable connector, shielded,

Cat.5e Screw terminal,

with shielding ring

**Recommended use**

Contacts	Cable outlet	Designation	Order No.
4	4-6 mm	M12-M04D-T-D6-SH	163 204 411 2001
	6-8 mm	M12-M04D-T-D8-SH	163 204 411 2002
	8-10 mm	M12-M04D-T-D10-SH	163 004 411 2502

D-Code



4pin

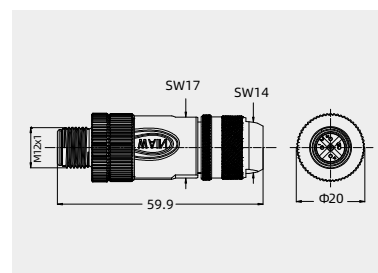

Male cable connector, shielded,

Cat.5e Screw terminal,

with shielding ring

Order crimp contacts separately

Contacts	Cable outlet	Designation	Order No.
4	4-6 mm	M12-MC04D-T-D6-SH	163 004 010 2001
	6-8 mm	M12-MC04D-T-D8-SH	163 004 010 2002
	8-10 mm	M12-MC04D-T-D10-SH	163 004 411 2501

D-Code



4pin

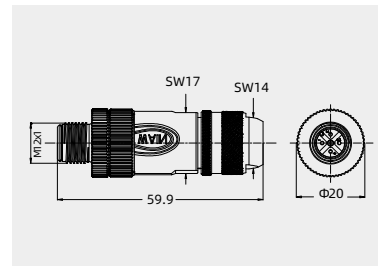

## Crimp contacts

Crimp contacts 5A

Contact resistance ≤ 3mΩ  
gold plated

Wire gauge(mm <sup>2</sup> )	Male	Order No.	Female	Order No.
0.09-0.25	CSGM-0.25	101 014 210 0101	CSGF-0.25	101 014 220 0101
0.13-0.33	CSGM-0.33	101 014 210 0201	CSGF-0.33	101 014 220 0201
0.33-0.52	CSGM-0.52	101 014 210 0501	CSGF-0.52	101 014 220 0501
0.52-0.82	CSGM-0.82	101 014 210 0701	CSGF-0.82	101 014 220 0701

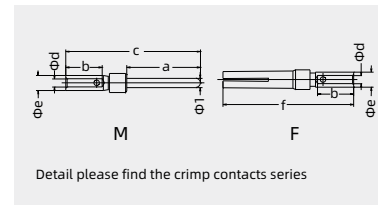

Detail please find the crimp contacts series

Tools

Crimping tool



Wire gauge	Designation	Order No.
0.09-0.82mm <sup>2</sup>	TL03	198 001 001 0002

Notes: The tools for crimp terminal may influence the product quality and stability. Please select the tools recognized by our company.

## M12-D Circular Connector

250V 4A

## Technical characteristics

Number of contacts	3-pole	4-pole	5-pole
Rated current(40°C )	4A	4A	4A
Rated voltage	250V	250V	125V
Rated impulse voltage	2500V	2500V	1500V
Pollution degree	3	3	3
Overvoltage categorie	II	II	II
Contact resistance	≤ 10 mΩ	≤ 10 mΩ	≤ 10 mΩ
Connector locking system	screw M12x1	screw M12x1	screw M12x1
Termination	Solder terminal	Solder terminal	Solder terminal
Wire gauge	max.0.75mm <sup>2</sup> (max.AWG18)	max.0.75mm <sup>2</sup> (max.AWG18)	max.0.75mm <sup>2</sup> (max.AWG18)
Cable outlet	4-8mm	4-8mm	4-8mm
Degree of protection	IP67	IP67	IP67
Mechanical operation	> 100	> 100	> 100
Limiting temperature	-40°C ...+85°C	-40°C ...+85°C	-40°C ...+85°C
Material group	II	II	II
Material of contact	copper alloy	copper alloy	copper alloy
Contact plating	Au	Au	Au
Insulating material	PA	PA	PA
Material of housing	PA/PBT/zinc alloy/copper alloy	PA/PBT/zinc alloy/copper alloy	PA/PBT/zinc alloy/copper alloy

Straight cable connectors 

Female cable connector,plastic locking system, solder



D-Code



Contacts	Cable outlet	Designation	Order No.
3	4-6 mm	M12P-FST03D-T-D6	163 003 423 3512
	6-8 mm	M12P-FST03D-T-D8	163 003 423 3513
4	4-6 mm	M12P-FST04D-T-D6	163 004 423 3520
	6-8 mm	M12P-FST04D-T-D8	163 004 423 3521
5	4-6 mm	M12P-FST05D-T-D6	163 005 423 3521
	6-8 mm	M12P-FST05D-T-D8	163 005 423 3522

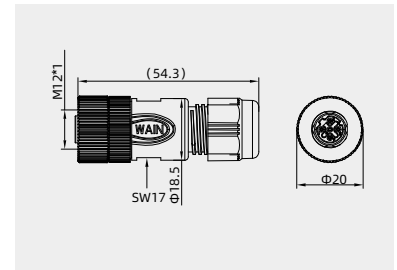

Female cable connector,metal locking system, solder



D-Code



Contacts	Cable outlet	Designation	Order No.
3	4-6 mm	M12-FST03D-T-D6	163 003 423 3514
	6-8 mm	M12-FST03D-T-D8	163 003 423 3515
4	4-6 mm	M12-FST04D-T-D6	163 004 423 3522
	6-8 mm	M12-FST04D-T-D8	163 004 423 3523
5	4-6 mm	M12-FST05D-T-D6	163 005 423 3523
	6-8 mm	M12-FST05D-T-D8	163 005 423 3520

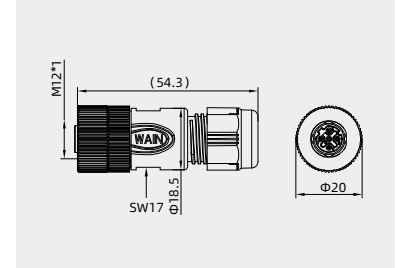

Female cable connector,stainless steel locking system, solder



D-Code



Contacts	Cable outlet	Designation	Order No.
3	4-6 mm	M12S-FST03D-T-D6	163 003 423 3516
	6-8 mm	M12S-FST03D-T-D8	163 003 423 3517
4	4-6 mm	M12S-FST04D-T-D6	163 004 423 3524
	6-8 mm	M12S-FST04D-T-D8	163 004 423 3525
5	4-6 mm	M12S-FST05D-T-D6	163 005 423 3524
	6-8 mm	M12S-FST05D-T-D8	163 005 423 3525

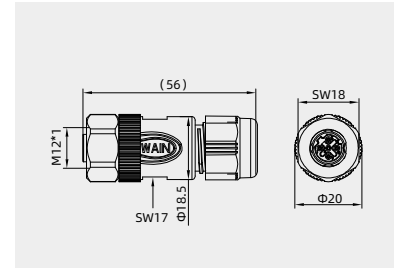



## M12-D Circular Connector

250V 4A

## Technical characteristics

Number of contacts	4-pole	5-pole
Rated current(40°C )	4A	4A
Rated voltage	250V	125V
Rated impulse voltage	2500V	1500V
Pollution degree	3	3
Overvoltage categorie	II	II
Contact resistance	≤ 10 mΩ	≤ 10 mΩ
Connector locking system	screw M12x1	screw M12x1
Termination	Solder terminal	Solder terminal
Wire gauge	max.0.75mm <sup>2</sup> (max.AWG18)	max.0.75mm <sup>2</sup> (max.AWG18)
Cable outlet	8-10mm	8-10mm
Degree of protection	IP67	IP67
Mechanical operation	> 100	> 100
Limiting temperature	-40°C ...+85°C	-40°C ...+85°C
Material group	II	II
Material of contact	copper alloy	copper alloy
Contact plating	Au	Au
Insulating material	PA	PA
Material of housing	PA/PBT/zinc alloy/copper alloy	PA/PBT/zinc alloy/copper alloy

## Straight cable connectors



Female cable connector, metal  
locking system, solder



D-Code



4pin



5pin

Contacts	Cable outlet	Designation	Order No.
4	8-10 mm	M12-FST04D-T-D10	163 004 423 3526
5	8-10 mm	M12-FST05D-T-D10	163 005 423 3526

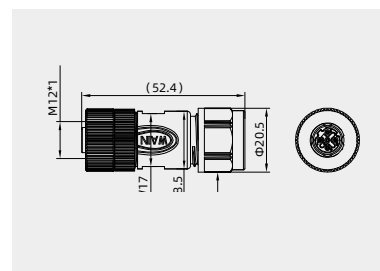

## M12-D Circular Connector

250V 4A

## Technical characteristics

Number of contacts	3-pole	4-pole	5-pole
Rated current(40°C )	4A	4A	4A
Rated voltage	250V	250V	125V
Rated impulse voltage	2500V	2500V	1500V
Pollution degree	3	3	3
Overvoltage categorie	II	II	II
Contact resistance	≤ 10 mΩ	≤ 10 mΩ	≤ 10 mΩ
Connector locking system	screw M12x1	screw M12x1	screw M12x1
Termination	Solder terminal	Solder terminal	Solder terminal
Wire gauge	max.0.75mm <sup>2</sup> (max.AWG18)	max.0.75mm <sup>2</sup> (max.AWG18)	max.0.75mm <sup>2</sup> (max.AWG18)
Cable outlet	4-8mm	4-8mm	4-8mm
Degree of protection	IP67	IP67	IP67
Mechanical operation	> 100	> 100	> 100
Limiting temperature	-40°C ...+85°C	-40°C ...+85°C	-40°C ...+85°C
Material group	II	II	II
Material of contact	copper alloy	copper alloy	copper alloy
Contact plating	Au	Au	Au
Insulating material	PA	PA	
Material of housing	PA/PBT/zinc alloy/copper alloy	PA/PBT/zinc alloy/copper alloy	PA/PBT/zinc alloy/copper alloy

Straight cable connectors 

Male cable connector, metal locking system, solder



D-Code



Contacts	Cable outlet	Designation	Order No.
3	4-6 mm	M12-MST03D-T-D6-SH	163 003 413 2502
	6-8 mm	M12-MST03D-T-D8-SH	163 003 413 2503
4	4-6 mm	M12-MST04D-T-D6-SH	163 204 413 2001
	6-8 mm	M12-MST04D-T-D8-SH	163 004 413 2502
5	4-6 mm	M12-MST05D-T-D6-SH	163 005 413 2502
	6-8 mm	M12-MST05D-T-D8-SH	163 005 413 2503

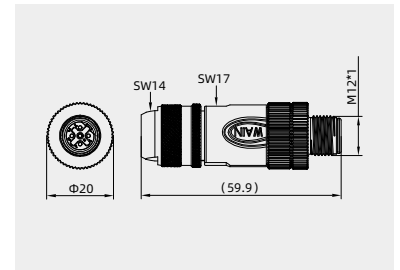

## M12-D Circular Connector

250V 4A

## Technical characteristics

Number of contacts	3-pole	4-pole	5-pole
Rated current(40°C )	4A	4A	4A
Rated voltage	250V	250V	125V
Rated impulse voltage	2500V	2500V	1500V
Pollution degree	3	3	3
Overvoltage categorie	II	II	II
Contact resistance	≤ 10 mΩ	≤ 10 mΩ	≤ 10 mΩ
Connector locking system	screw M12x1	screw M12x1	screw M12x1
Termination	Solder terminal	Solder terminal	Solder terminal
Wire gauge	max.0.75mm <sup>2</sup> (max.AWG18)	max.0.75mm <sup>2</sup> (max.AWG18)	max.0.75mm <sup>2</sup> (max.AWG18)
Cable outlet	4-8mm	4-8mm	4-8mm
Degree of protection	IP67	IP67	IP67
Mechanical operation	> 100	> 100	> 100
Limiting temperature	-40°C ...+85°C	-40°C ...+85°C	-40°C ...+85°C
Material group	II	II	II
Material of contact	copper alloy	copper alloy	copper alloy
Contact plating	Au	Au	Au
Insulating material	PA	PA	PA
Material of housing	PA/PBT/zinc alloy/copper alloy	PA/PBT/zinc alloy/copper alloy	PA/PBT/zinc alloy/copper alloy

Angled cable connectors 

## Female cable connector,plastic locking system, solder



D-Code



Contacts	Cable outlet	Designation	Order No.
3	4-6 mm	M12P-FST03D-S-D6	163 003 523 3513
	6-8 mm	M12P-FST03D-S-D8	163 003 523 3514
4	4-6 mm	M12P-FST04D-S-D6	163 004 523 3516
	6-8 mm	M12P-FST04D-S-D8	163 004 523 3517
5	4-6 mm	M12P-FST05D-S-D6	163 005 523 3516
	6-8 mm	M12P-FST05D-S-D8	163 005 523 3517

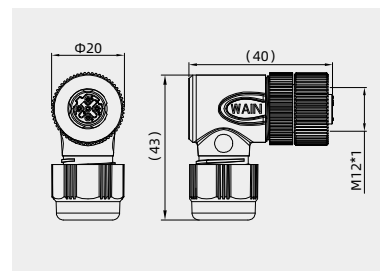

## Female cable connector,metal locking system, solder



D-Code



Contacts	Cable outlet	Designation	Order No.
3	4-6 mm	M12-FST03D-S-D6	163 003 523 3515
	6-8 mm	M12-FST03D-S-D8	163 003 523 3516
4	4-6 mm	M12-FST04D-S-D6	163 004 523 3518
	6-8 mm	M12-FST04D-S-D8	163 004 523 3519
5	4-6 mm	M12-FST05D-S-D6	163 005 523 3518
	6-8 mm	M12-FST05D-S-D8	163 005 523 3519

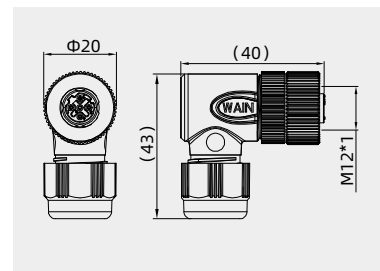

## Female cable connector,stainless steel locking system, solder



D-Code



Contacts	Cable outlet	Designation	Order No.
3	4-6 mm	M12S-FST03D-S-D6	163 003 523 3517
	6-8 mm	M12S-FST03D-S-D8	163 003 523 3518
4	4-6 mm	M12S-FST04D-S-D6	163 004 523 3520
	6-8 mm	M12S-FST04D-S-D8	163 004 523 3521
5	4-6 mm	M12S-FST05D-S-D6	163 005 523 3520
	6-8 mm	M12S-FST05D-S-D8	163 005 523 3521

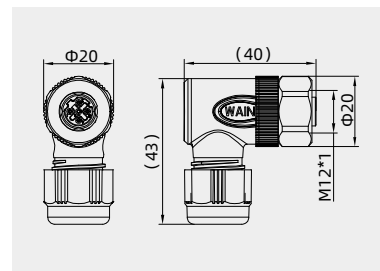

M12-D

## M12-D Circular Connector

250V 4A

## Technical characteristics

Number of contacts	3-pole	4-pole	5-pole
Rated current(40°C )	4A	4A	4A
Rated voltage	250V	250V	125V
Rated impulse voltage	2500V	2500V	1500V
Pollution degree	3	3	3
Overvoltage categorie	II	II	II
Contact resistance	≤ 10 mΩ	≤ 10 mΩ	≤ 10 mΩ
Connector locking system	screw M12x1	screw M12x1	screw M12x1
Termination	Solder terminal	Solder terminal	Solder terminal
Wire gauge	max.0.75mm <sup>2</sup> (max.AWG18)	max.0.75mm <sup>2</sup> (max.AWG18)	max.0.75mm <sup>2</sup> (max.AWG18)
Cable outlet	4-8mm	4-8mm	4-8mm
Degree of protection	IP67	IP67	IP67
Mechanical operation	> 100	> 100	> 100
Limiting temperature	-40°C ...+85°C	-40°C ...+85°C	-40°C ...+85°C
Material group	II	II	II
Material of contact	copper alloy	copper alloy	copper alloy
Contact plating	Au	Au	Au
Insulating material	PA	PA	PA
Material of housing	PA/PBT/zinc alloy/copper alloy	PA/PBT/zinc alloy/copper alloy	PA/PBT/zinc alloy/copper alloy

## Angled cable connectors



Female cable connector,metal locking system, solder



D-Code

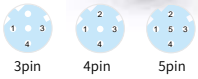

Contacts	Cable outlet	Designation	Order No.
3	4-6 mm	M12-FST03D-S-D6-SH	163 003 523 2500
	6-8 mm	M12-FST03D-S-D8-SH	163 003 523 2501
4	4-6 mm	M12-FST04D-S-D6-SH	163 004 523 2504
	6-8 mm	M12-FST04D-S-D8-SH	163 004 523 2505
5	4-6 mm	M12-FST05D-S-D6-SH	163 005 523 2504
	6-8 mm	M12-FST05D-S-D8-SH	163 005 523 2505

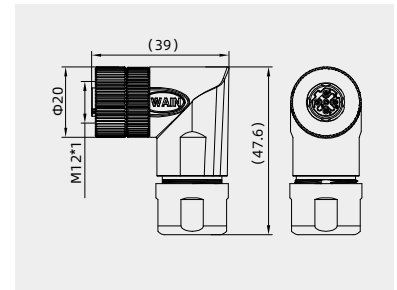

# M12-D Circular Connector

250V 4A

## Technical characteristics

Number of contacts	4
Rated current (40°C)	4A
Rated voltage	250V
Rated impulse voltage	2500V
Pollution degree	3
Overvoltage categorie	II
Contact resistance	≤ 10 mΩ
Connector locking system	screw M12x1
Termination	screw, <b>crimp</b>
Wire gauge	max.0.75mm <sup>2</sup> (max.AWG18), max.0.82mm <sup>2</sup> (max.AWG18)
Cable outlet	4-6mm, 6-8mm
Degree of protection	IP67
Mechanical operation	> 100
Limiting temperature	-40°C ...+85°C
Material group	II
Material of contact	copper alloy
Contact plating	Au
Insulating material	PA
Material of housing	zinc diecasting nickel plated

## Straight cable connectors, shielded

Female cable connector, shielded,  
Cat.5e Screw terminal,  
with shielding ring

**Recommended use**



Female cable connector, shielded,  
Cat.5e Crimp terminal,  
with shielding ring  
Order crimp contacts separately



Female cable connector, shielded,  
solder



Contacts	Cable outlet	Designation	Order No.
4	4-6 mm	M12-F04D-T-D6-SH	163 204 421 2001
	6-8 mm	M12-F04D-T-D8-SH	163 204 421 2002
	8-10 mm	M12-F04D-T-D10-SH	163 004 421 2500

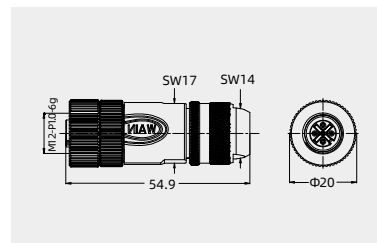

Contacts	Cable outlet	Designation	Order No.
4	4-6 mm	M12-FC04D-T-D6-SH	163 004 020 2001
	6-8 mm	M12-FC04D-T-D8-SH	163 004 020 2002
	8-10 mm	M12-FC04D-T-D10-SH	163 004 421 2501

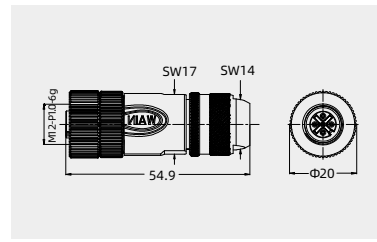

Contacts	Cable outlet	Designation	Order No.
3	4-6 mm	M12-FST03D-T-D6-SH	163 003 423 2504
	6-8 mm	M12-FST03D-T-D8-SH	163 003 423 2505
4	4-6 mm	M12-FST04D-T-D6-SH	163 004 423 2503
	6-8 mm	M12-FST04D-T-D8-SH	163 004 423 2504
5	4-6 mm	M12-FST05D-T-D6-SH	163 005 423 2502
	6-8 mm	M12-FST05D-T-D8-SH	163 005 423 2503

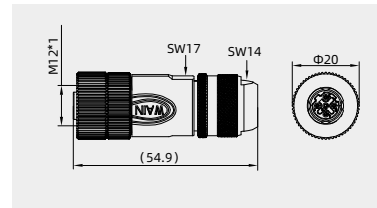

## Crimp contacts

Crimp contacts 5A

Contact resistance ≤ 3mΩ  
gold plated



Tools

Crimping tool



Wire gauge(mm <sup>2</sup> )	Male	Order No.	Female	Order No.
0.09-0.25	CSGM-0.25	101 014 210 0101	CSGF-0.25	101 014 220 0101
0.13-0.33	CSGM-0.33	101 014 210 0201	CSGF-0.33	101 014 220 0201
0.33-0.52	CSGM-0.52	101 014 210 0501	CSGF-0.52	101 014 220 0501
0.52-0.82	CSGM-0.82	101 014 210 0701	CSGF-0.82	101 014 220 0701

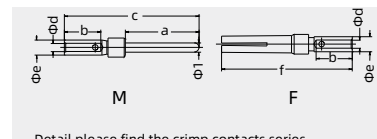

Detail please find the crimp contacts series

Wire gauge	Designation	Order No.
0.09-0.82mm <sup>2</sup>	TL03	198 001 001 0002

Notes: The tools for crimp terminal may influence the product quality and stability. Please select the tools recognized by our company.

## M12-D Circular Connector

250V 4A

## Technical characteristics

Number of contacts	4
Rated current (40°C)	4A
Rated voltage	250V
Rated impulse voltage	2500V
Pollution degree	3
Overvoltage categorie	II
Contact resistance	≤ 10 mΩ
Connector locking system	screw M12x1
Termination	crimp
Wire gauge	max.0.82mm <sup>2</sup> (max.AWG18)
Cable outlet	6-8mm
Degree of protection	IP67
Mechanical operation	> 100
Limiting temperature	-40°C ...+85°C
Material group	II
Material of contact	copper alloy
Contact plating	Au
Insulating material	PA
Material of housing	zinc diecasting nickel plated

## Flange base cable connector, shielded

Male cable connector, shielded,  
Cat.5e Crimp terminal ,  
with shielding ring  
Order crimp contacts separately  
**Recommended use**

D-Code



Contacts	Cable outlet	Designation	Order No.
4	4-6 mm	M12-MC04D-CCT/R-M16-D8-SH	163 004 510 2001

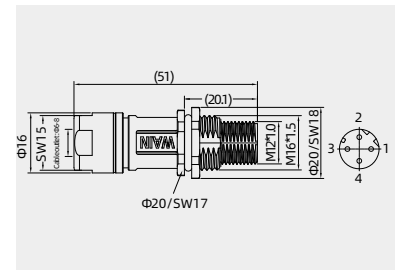

## Crimp contacts

Crimp contacts 5A

Contact resistance ≤ 3mΩ  
gold plated



Wire gauge(mm <sup>2</sup> )	Male	Order No.	Female	Order No.
0.09-0.25	CSGM-0.25	101 014 210 0101	CSGF-0.25	101 014 220 0101
0.13-0.33	CSGM-0.33	101 014 210 0201	CSGF-0.33	101 014 220 0201
0.33-0.52	CSGM-0.52	101 014 210 0501	CSGF-0.52	101 014 220 0501
0.52-0.82	CSGM-0.82	101 014 210 0701	CSGF-0.82	101 014 220 0701

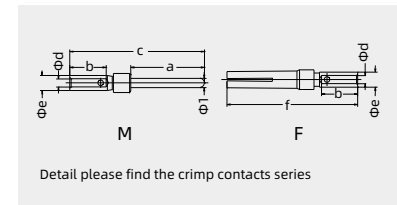

Tools

Crimping tool



Wire gauge	Designation	Order No.
0.09-0.82mm <sup>2</sup>	TL03	198 001 001 0002

Notes: The tools for crimp terminal may influence the product quality and stability. Please select the tools recognized by our company.

## M12-D Circular Connector

250V 4A

## Technical characteristics

Number of contacts	4
Rated current (40°C)	4A
Rated voltage	250V
Rated impulse voltage	2500V
Pollution degree	3
Overvoltage categorie	II
Contact resistance	≤ 10 mΩ
Connector locking system	screw M12x1
Termination	crimp
Wire gauge	max.0.82mm <sup>2</sup> (max.AWG18)
Cable outlet	6-8mm
Degree of protection	IP67
Mechanical operation	> 100
Limiting temperature	-40°C ...+85°C
Material group	II
Material of contact	copper alloy
Contact plating	Au
Insulating material	PA
Material of housing	zinc diecasting nickel plated

## Flange base cable connector, shielded

Female cable connector, shielded,

Cat.5e Crimp terminal ,

with shielding ring

Order crimp contacts separately

Recommended use

D-Code



4pin



Contacts	Cable outlet	Designation	Order No.
4	4-6 mm	M12-FC04D-CCT/R-M16-D8-SH	163 004 520 2003

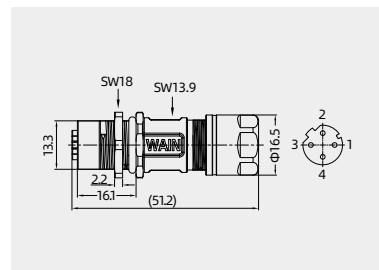

## Crimp contacts

Crimp contacts 5A

Contact resistance ≤ 3mΩ  
gold plated

Wire gauge(mm <sup>2</sup> )	Male	Order No.	Female	Order No.
0.09-0.25	CSGM-0.25	101 014 210 0101	CSGF-0.25	101 014 220 0101
0.13-0.33	CSGM-0.33	101 014 210 0201	CSGF-0.33	101 014 220 0201
0.33-0.52	CSGM-0.52	101 014 210 0501	CSGF-0.52	101 014 220 0501
0.52-0.82	CSGM-0.82	101 014 210 0701	CSGF-0.82	101 014 220 0701

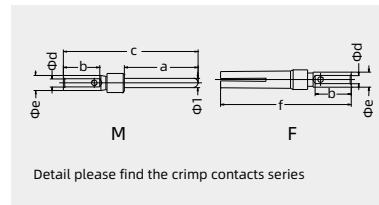

Detail please find the crimp contacts series

Tools

Crimping tool



Wire gauge	Designation	Order No.
0.09-0.82mm <sup>2</sup>	TL03	198 001 001 0002

Notes: The tools for crimp terminal may influence the product quality and stability. Please select the tools recognized by our company.

M12-D Circular Connector

• assembly instruction/Component part drawing

- Assembly instruction
- Strip length male/female cable connector, with shielding ring, screw terminal

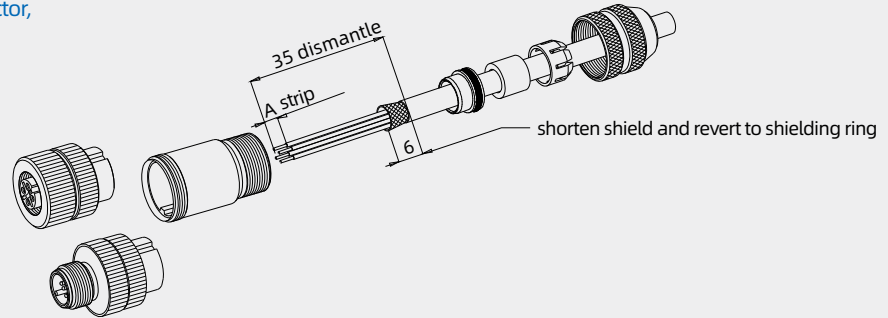

- Assembly instruction
- Strip length male/female cable connector, with shielding ring, crimp terminal

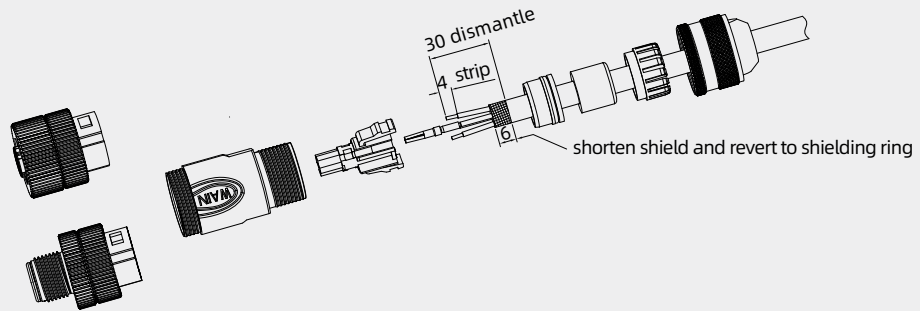

- Component part drawing
- Cable connector with shielding ring

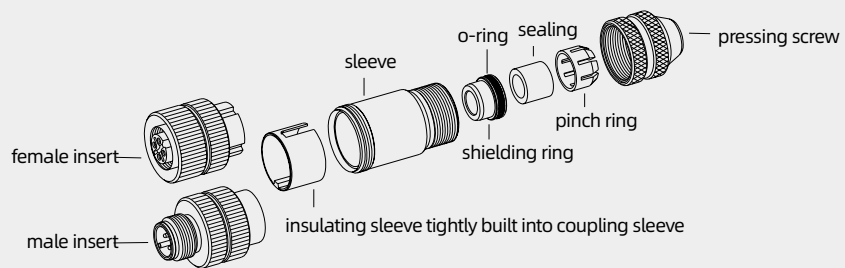



- Rating

- Attenuation curve according to DIN 47250-6 for straight cable connectors screw termination (cable version IEEE 802.3)

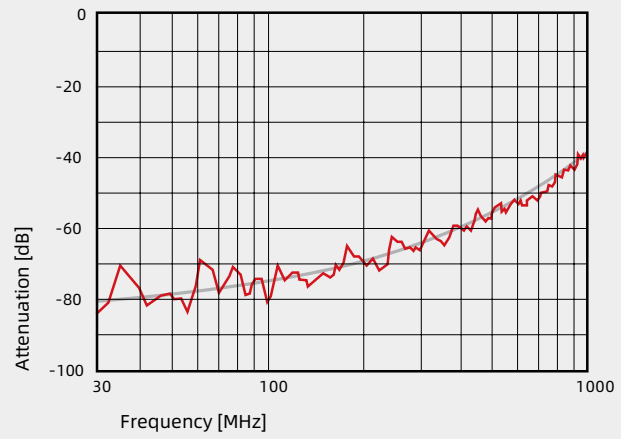

## M12-D Circular Connector

250V 4A

## Technical characteristics

Number of contacts	4
Rated current (40°C)	4A
Rated voltage	250V
Rated impulse voltage	2500V
Pollution degree	3
Overvoltage categorie	II
Contact resistance	≤ 10 mΩ
Connector locking system	screw M12x1
Termination	crimp, moulded
Wire gauge	0.34mm <sup>2</sup> (AWG22)
Cable outlet	-
Degree of protection	IP67
Mechanical operation	> 500
Limiting temperature	-20°C ...+60°C
Material group	II
Material of contact	copper alloy
Contact plating	Au
Insulating material	PA
Material of housing	TPU

## Straight cable connectors, cable

## Male cable connector, PROFINET



## D-Code



4pin

Contacts	Cable length	Designation	Order No.
4	1.5 m	M12-M04D-T-1.5-PUR-PFN	163 204 401 4081
	5.0 m	M12-M04D-T-5.0-PUR-PFN	163 204 401 4082

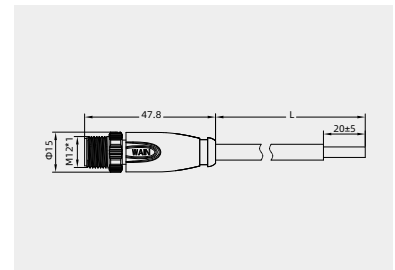

## Male cable connector, Cat.5e Ethernet



## D-Code



4pin

Contacts	Cable length	Designation	Order No.
4	1.5 m	M12-M04D-T-1.5-PUR-Cat.5e	163 204 401 4091
	5.0 m	M12-M04D-T-5.0-PUR-Cat.5e	163 204 401 4092

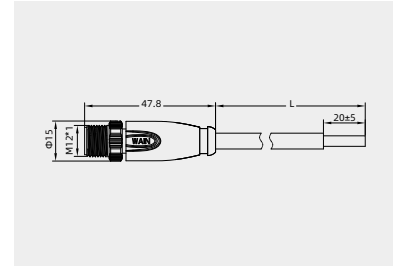

## M12-D Circular Connector

250V 4A

## Technical characteristics

Number of contacts	4
Rated current (40°C)	4A
Rated voltage	250V
Rated impulse voltage	2500V
Pollution degree	3
Overvoltage categorie	II
Contact resistance	≤ 10 mΩ
Connector locking system	screw M12x1
Termination	crimp, moulded
Wire gauge	0.34mm <sup>2</sup> (AWG22)
Cable outlet	-
Degree of protection	IP67
Mechanical operation	> 500
Limiting temperature	-20°C ...+60°C
Material group	II
Material of contact	copper alloy
Contact plating	Au
Insulating material	PA
Material of housing	TPU

## Straight cable connectors, cable

## Female cable connector, PROFINET



D-Code



4pin

Contacts	Cable length	Designation	Order No.
4	1.5 m	M12-F04D-T-1.5-PUR-PFN	163 204 402 4081
	5.0 m	M12-F04D-T-5.0-PUR-PFN	163 204 402 4082

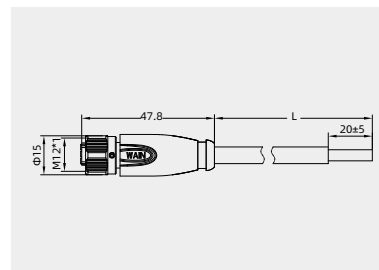

## Female cable connector, Cat.5e

Ethernet



D-Code



4pin

Contacts	Cable length	Designation	Order No.
4	1.5 m	M12-F04D-T-1.5-PUR-Cat.5e	163 204 402 4091
	5.0 m	M12-F04D-T-5.0-PUR-Cat.5e	163 204 402 4092

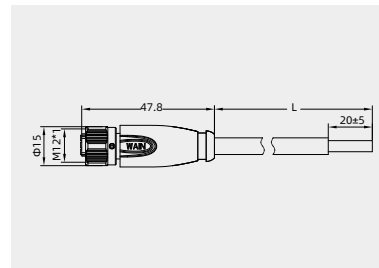

M12-D

## M12-D Circular Connector

250V 4A

## Technical characteristics

Number of contacts	4
Rated current (40°C)	4A
Rated voltage	250V
Rated impulse voltage	2500V
Pollution degree	3
Overvoltage categorie	II
Contact resistance	≤ 10 mΩ
Connector locking system	screw M12x1
Termination	crimp, moulded
Wire gauge	0.34mm <sup>2</sup> (AWG22)
Cable outlet	-
Degree of protection	IP67
Mechanical operation	> 500
Limiting temperature	-20°C ...+60°C
Material group	II
Material of contact	copper alloy
Contact plating	Au
Insulating material	PA
Material of housing	TPU

## Cable connectors-wire jumper

## Male cable connector, PROFINET



D-Code



4pin

Contacts	Cable length	Designation	Order No.
4	1.5 m	M12-M04D-T/M04D-T-1.5-PUR-PFN	163 004 401 4508
	5.0 m	M12-M04D-T/M04D-T-5.0-PUR-PFN	163 004 401 4507

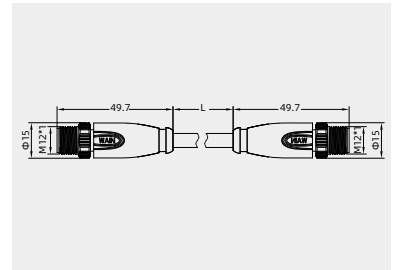

## Female cable connector, PROFINET



D-Code



4pin

Contacts	Cable length	Designation	Order No.
4	1.5 m	M12-F04D-T/F04D-T-1.5-PUR-PFN	163 004 402 4510
	5.0 m	M12-F04D-T/F04D-T-5.0-PUR-PFN	163 004 402 4509

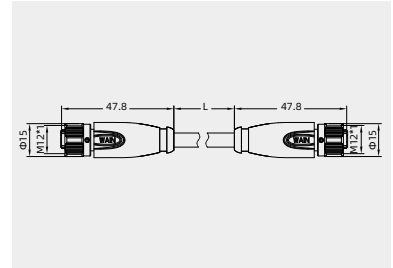

## Male,Female, PROFINET



D-Code



4pin

4pin

Contacts	Cable length	Designation	Order No.
4	1.5 m	M12-M04D-T/F04D-T-1.5-PUR-PFN	163 004 400 4016
	5.0 m	M12-M04D-T/F04D-T-5.0-PUR-PFN	163 004 401 4502

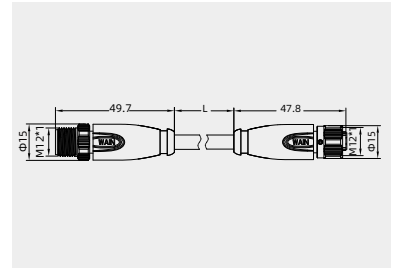

## M12-D Circular Connector

250V 4A

## Technical characteristics

Number of contacts	4
Rated current (40°C)	4A
Rated voltage	250V
Rated impulse voltage	2500V
Pollution degree	3
Overvoltage categorie	II
Contact resistance	≤ 10 mΩ
Connector locking system	screw M12x1
Termination	crimp, moulded
Wire gauge	0.34mm <sup>2</sup> (AWG22)
Cable outlet	-
Degree of protection	IP67
Mechanical operation	> 500
Limiting temperature	-20°C ...+60°C
Material group	II
Material of contact	copper alloy
Contact plating	Au
Insulating material	PA
Material of housing	TPU

## Cable connectors-wire jumper

## Male cable connector,Cat.5e

## Ethernet



## D-Code



4pin

Contacts	Cable length	Designation	Order No.
4	1.5 m	M12-M04D-T/M04D-T-1.5-PUR-Cat.5e	163 004 401 4510
	5.0 m	M12-M04D-T/M04D-T-5.0-PUR-Cat.5e	163 004 401 4509

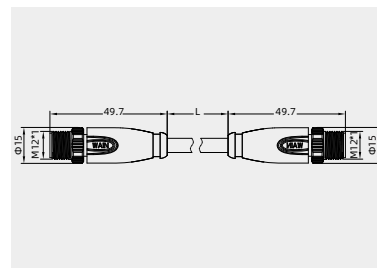

## Female cable connector, Cat.5e

## Ethernet



## D-Code



4pin

Contacts	Cable length	Designation	Order No.
4	1.5 m	M12-F04D-T/F04D-T-1.5-PUR-Cat.5e	163 004 402 4512
	5.0 m	M12-F04D-T/F04D-T-5.0-PUR-Cat.5e	163 004 402 4511

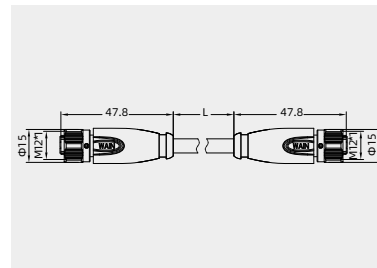

## Cat.5e Ethernet



## D-Code

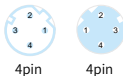

4pin

4pin

Contacts	Cable length	Designation	Order No.
4	1.5 m	M12-M04D-T/F04D-T-1.5-PUR-Cat.5e	163 004 400 4017
	5.0 m	M12-M04D-T/F04D-T-5.0-PUR-Cat.5e	163 004 001 4013

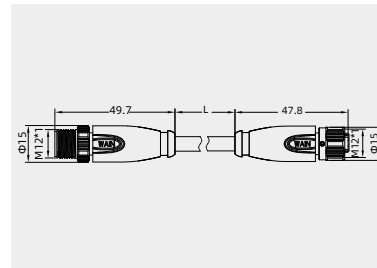

•Further cable length upon request, minimum order quantity is 200 pcs.

## M12-D Circular Connector

250V 4A

### Technical characteristics

Number of contacts	4
Rated current (40°C)	4A
Rated voltage	250V
Rated impulse voltage	2500V
Pollution degree	3
Overvoltage categorie	II
Contact resistance	≤ 10 mΩ
Connector locking system	screw M12x1
Termination	crimp, moulded
Wire gauge	0.14mm <sup>2</sup> (AWG26)
Cable outlet	-
Degree of protection	IP67
Mechanical operation	> 500
Limiting temperature	-20°C ...+60°C
Material group	II
Material of contact	copper alloy
Contact plating	Au
Insulating material	PA
Material of housing	TPU

### Straight cable connectors, cable

#### Male cable connector, Cat.5e

Ethernet



D-Code



4pin

Contacts	Cable length	Designation	Order No.
4	1.5 m	M12-M04D-T/RJ45-T-1.5-PUR-Cat.5e	163 004 001 4021
	5.0 m	M12-M04D-T/RJ45-T-5.0-PUR-Cat.5e	163 004 001 4004

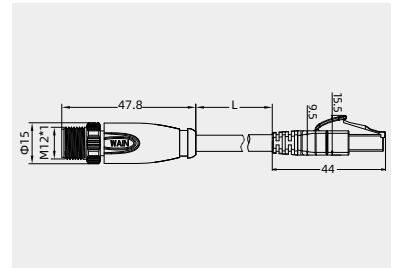

#### Female cable connector, Cat.5e

Ethernet



D-Code



4pin

Contacts	Cable length	Designation	Order No.
4	1.5 m	M12-F04D-T/RJ45-T-1.5-PUR-Cat.5e	163 004 402 4506
	5.0 m	M12-F04D-T/RJ45-T-5.0-PUR-Cat.5e	163 004 402 4507

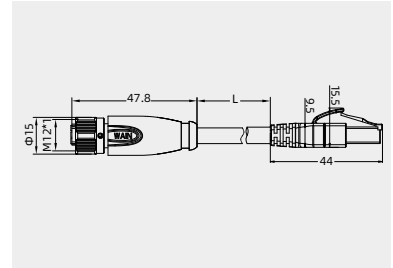

#### Cat.5e Ethernet

Ethernet, Cat.5e



Contacts	Cable length	Designation	Order No.
4	1.5 m	2RJ45-T-M04-T-1.5-PUR-Cat.5e	172 004 000 4002
	5.0 m	2RJ45-T-M04-T-5.0-PUR-Cat.5e	172 004 000 4001

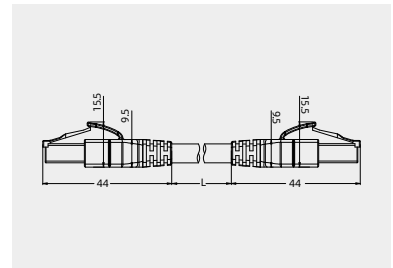

## M12-D Circular Connector

60V 1A

## Technical characteristics

Number of contacts	4
Rated current (40°C)	1A
Rated voltage	60V
Rated impulse voltage	2500V
Pollution degree	3
Overvoltage categorie	II
Contact resistance	≤ 10 mΩ
Connector locking system	screw M12x1
Termination	crimp, moulded
Wire gauge	0.34mm <sup>2</sup> (AWG22)
Cable outlet	-
Degree of protection	IP67
Mechanical operation	> 100
Limiting temperature	-20°C ...+60°C
Material group	II
Material of contact	copper alloy
Contact plating	Au
Insulating material	PA
Material of housing	TPU

## Straight cable connectors, cable

## Male cable connector, PROFINET



D-Code



4pin

Contacts	Cable length	Designation	Order No.
4	1.5 m	M12-M04D-T/RJ45P-T-1.5-PUR-PFN	163 004 001 4056
	5.0 m	M12-M04D-T/RJ45P-T-5.0-PUR-PFN	163 004 001 4057

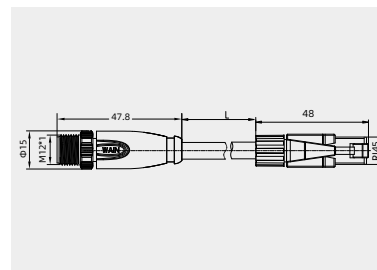

## Female cable connector, PROFINET



D-Code



4pin

Contacts	Cable length	Designation	Order No.
4	1.5 m	M12-F04D-T/RJ45P-T-1.5-PUR-PFN	163 004 002 4004
	5.0 m	M12-F04D-T/RJ45P-T-5.0-PUR-PFN	163 004 002 4005

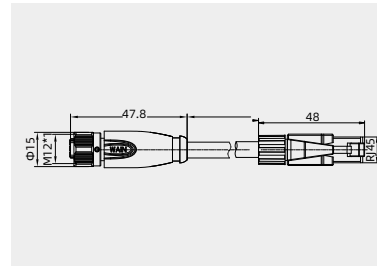

M12-D

## Cable Technical characteristics

## Technical characteristics

Number of contacts	4
Wire gauge mm <sup>2</sup>	2 x 2 x AWG 22
Material jacket	PUR
Insulation wire	Polyolefin
Design of wire (mm)	7 x 0,25 (AWG 22)
Cable jacket (mm)	6.7
Resistance of wire	55 Ω/Km
Temperature range (cable in move)	- 5 ° C / + 60 ° C
Temperature range (cable not in move)	- 20 ° C / + 60 ° C
Bending radius (cable in move)	min. 100 mm
Bending radius (cable not in move)	min. 35 mm
Approval	Profinet, UL 20236



## M12-D Circular Connector

250V 4A

## Technical characteristics

Number of contacts	4
Rated current (40°C)	4A
Rated voltage	250V
Rated impulse voltage	2500V
Pollution degree	3
Overvoltage categorie	II
Contact resistance	≤ 10 mΩ
Connector locking system	screw M12x1
Termination	PUR-cable
Wire gauge	AWG 22
Cable outlet	-
Degree of protection	IP67
Mechanical operation	> 100
Limiting temperature	-20°C ...+60°C
Material group	II
Material of contact	copper alloy
Contact plating	Au
Insulating material	PA
Material of housing	zinc diecasting nickel plated

## Receptacles

Male panel mount connector ,  
PROFINET-cable, shielded

D-Code



4pin

Contacts	Cable length	screw	Designation	Order No.
4	0.5m	PG9	M12-M04D-BK-PG9-PFN	163 004 301 4017
	0.5m	M16x1.5	M12-M04D-BK-M16-PFN	163 204 301 4022

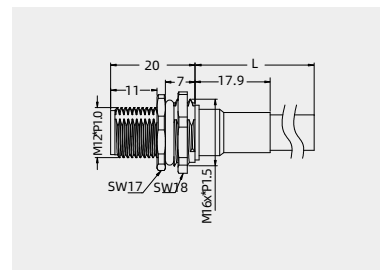
Male panel mount connector ,  
PROFINET-cable, shielded

D-Code



4pin

Contacts	Cable length	screw	Designation	Order No.
4	0.5m	PG9	M12-M04D-BKR-PG9-PFN	163 204 301 4012
	0.5m	M16x1.5	M12-M04D-BKR-M16-PFN	163 004 301 4018

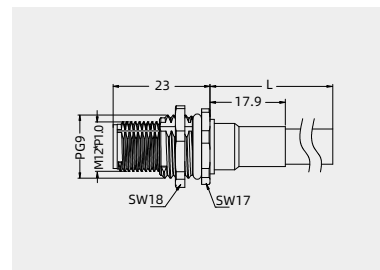

M12-D

## M12-D Circular Connector

250V 4A

## Technical characteristics

Number of contacts	4
Rated current (40°C)	4A
Rated voltage	250V
Rated impulse voltage	2500V
Pollution degree	3
Overvoltage categorie	II
Contact resistance	≤ 10 mΩ
Connector locking system	screw M12x1
Termination	PUR-cable
Wire gauge	AWG 22
Cable outlet	-
Degree of protection	IP67
Mechanical operation	> 100
Limiting temperature	-20°C ...+60°C
Material group	II
Material of contact	copper alloy
Contact plating	Au
Insulating material	PA
Material of housing	zinc diecasting nickel plated

## Receptacles

Female panel mount connector ,  
PROFINET-cable, shielded

D-Code



4pin

Contacts	Cable length	screw	Designation	Order No.
4	0.5m	PG9	M12-F04D-BK-PG9-PFN	163 004 302 4022
	0.5m	M16x1.5	M12-F04D-BK-M16-PFN	163 204 302 4022

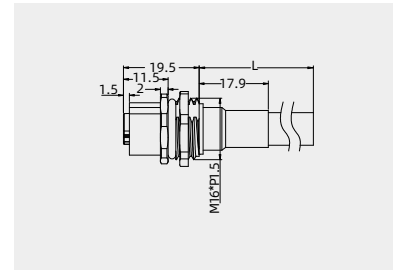
Female panel mount connector ,  
PROFINET-cable, shielded

D-Code



4pin

Contacts	Cable length	screw	Designation	Order No.
4	0.5m	PG9	M12-F04D-BKR-PG9-PFN	163 204 302 4012
	0.5m	M16x1.5	M12-F04D-BKR-M16-PFN	163 004 302 4023

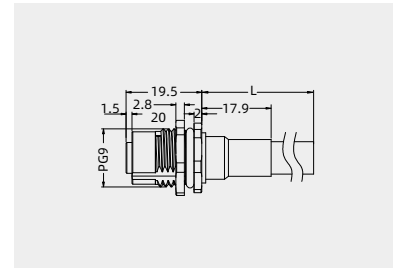

## M12-D Circular Connector

250V 4A

## Technical characteristics

Number of contacts	4
Rated current (40°C)	4A
Rated voltage	250V
Rated impulse voltage	2500V
Pollution degree	3
Overvoltage categorie	II
Contact resistance	≤ 10 mΩ
Connector locking system	screw M12x1
Termination	single wires
Wire gauge	max.0.75mm <sup>2</sup> (AWG18)
Cable outlet	-
Degree of protection	IP67
Mechanical operation	> 100
Limiting temperature	-40°C ...+85°C
Material group	II
Material of contact	copper alloy
Contact plating	Au
Insulating material	PA
Material of housing	zinc diecasting nickel plated

## Receptacles

Male panel mount connector  
with single wires,0.25mm<sup>2</sup>

D-Code



4pin

Contacts	Cable length	screw	Designation	Order No.
4	0.5m	PG9	M12-M04D-BK-PG9-W0.25	163 004 301 4003
	0.5m	M16x1.5	M12-M04D-BK-M16-W0.25	163 204 301 4021

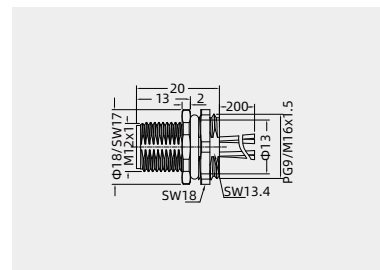
Male panel mount connector  
with single wires,0.25mm<sup>2</sup>

D-Code



4pin

Contacts	Cable length	screw	Designation	Order No.
4	0.5m	PG9	M12-M04D-BKR-PG9-W0.25	163 004 301 4014
	0.5m	M16x1.5	M12-M04D-BKR-M16-W0.25	163 004 301 4016

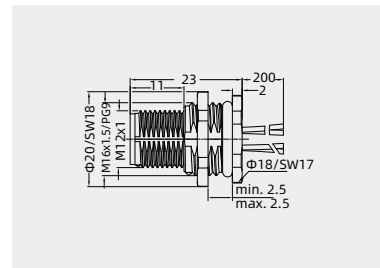

M12-D

## M12-D Circular Connector

250V 4A

## Technical characteristics

Number of contacts	4
Rated current (40°C)	4A
Rated voltage	250V
Rated impulse voltage	2500V
Pollution degree	3
Overvoltage categorie	II
Contact resistance	≤ 10 mΩ
Connector locking system	screw M12x1
Termination	dip solder
Wire gauge	-
Cable outlet	-
Degree of protection	IP67
Mechanical operation	> 100
Limiting temperature	-40°C ...+85°C
Material group	II
Material of contact	copper alloy
Contact plating	Au
Insulating material	PA
Material of housing	zinc diecasting nickel plated

## Socket

## Male panel mount connector, solder



D-Code



4pin

Contacts	screw	Designation	Order No.
4	PG9	M12-M04D-BK-PG9-C	163 004 301 1006
	M16x1.5	M12-M04D-BK-M16-C	163 004 301 1007

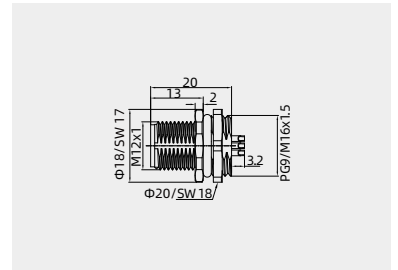

## Male panel mount connector, dip solder



D-Code



4pin

Contacts	screw	Designation	Order No.
4	PG9	M12-M04D-BK-PG9-D	163 004 314 1005
	M16x1.5	M12-M04D-BK-M16-D	163 004 314 1006

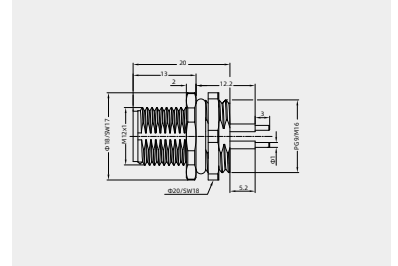

## Male panel mount connector, dip solder



D-Code



4pin

Contacts	screw	Designation	Order No.
4	PG9	M12-M04D-BKR-PG9-D	163 004 314 1007
	M16x1.5	M12-M04D-BKR-M16-D	163 004 314 1008

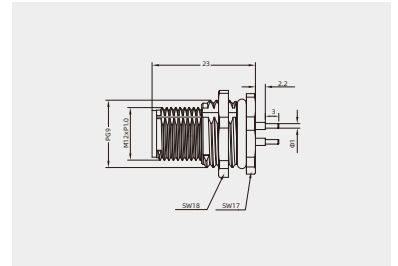

## M12-D Circular Connector

250V 4A

## Technical characteristics

Number of contacts	4
Rated current (40°C)	4A
Rated voltage	250V
Rated impulse voltage	2500V
Pollution degree	3
Overvoltage categorie	II
Contact resistance	≤ 10 mΩ
Connector locking system	screw M12x1
Termination	single wires
Wire gauge	max.0.75mm <sup>2</sup> (AWG18)
Cable outlet	-
Degree of protection	IP67
Mechanical operation	> 100
Limiting temperature	-40°C ...+85°C
Material group	II
Material of contact	copper alloy
Contact plating	Au
Insulating material	PA
Material of housing	zinc diecasting nickel plated

## Receptacles

Female panel mount connector  
with single wires,0.25mm<sup>2</sup>

D-Code



4pin

Contacts	screw	Designation	Order No.
4	PG9	M12-F04D-BK-PG9-W0.25	163 204 302 4001
	M16x1.5	M12-F04D-BK-M16-W0.25	163 204 302 4021

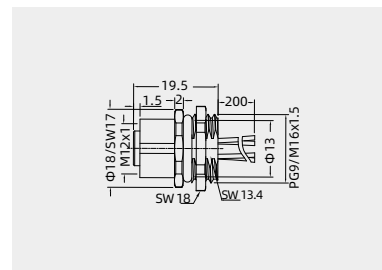
Female panel mount connector  
with single wires,0.25mm<sup>2</sup>

D-Code



4pin

Contacts	screw	Designation	Order No.
4	PG9	M12-F04D-BKR-PG9-W0.25	163 204 302 4011
	M16x1.5	M12-F04D-BKR-M16-W0.25	163 204 302 4031

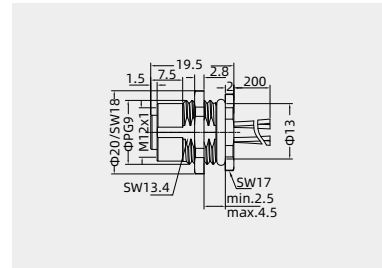
Female panel mount connector,  
dip solder

D-Code



4pin

插针数	螺纹	型号	订货号
4	PG9	M12-F04D-BKR-PG9-DPE	163 004 324 2505
	M16x1.5	M12-F04D-BKR-M16-DPE	163 004 324 2504

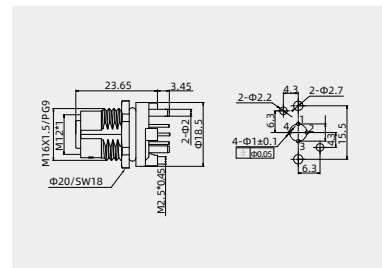

## M12-D Circular Connector

250V 4A

## Technical characteristics

Number of contacts	4
Rated current (40°C)	4A
Rated voltage	250V
Rated impulse voltage	2500V
Pollution degree	3
Overvoltage categorie	II
Contact resistance	≤ 10 mΩ
Connector locking system	screw M12x1
Termination	dip solder
Wire gauge	-
Cable outlet	-
Degree of protection	IP67
Mechanical operation	> 100
Limiting temperature	-40°C ...+85°C
Material group	II
Material of contact	copper alloy
Contact plating	Au
Insulating material	PA
Material of housing	zinc diecasting nickel plated

## Receptacles

Female panel mount connector,  
solder

D-Code



4pin

Contacts	screw	Designation	Order No.
4	PG9	M12-F04D-BK-PG9-C	163 204 324 1002
	M16x1.5	M12-F04D-BK-M16-C	163 004 302 1006

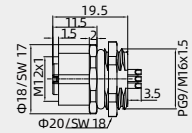
Female panel mount connector,  
dip solder

D-Code



4pin

Contacts	screw	Designation	Order No.
4	PG9	M12-F04D-BK-PG9-D	163 204 324 1001

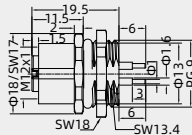
Female panel mount connector,  
dip solder

D-Code



4pin

Contacts	screw	Designation	Order No.
4	PG9	M12-F04D-BKR-PG9-D	163 204 324 1011

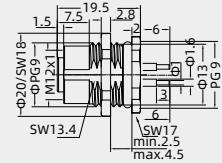

## M12-D Circular Connector

50V 4A

## Technical characteristics

Number of contacts	4
Rated current (40°C)	4A
Rated voltage	50V
Rated impulse voltage	1500V
Pollution degree	3
Overvoltage categorie	III
Contact resistance	≤ 10 mΩ
Insulation resistance	≥ 100 mΩ
Connector locking system	screw M12x1
Termination	dip solder
Wire gauge	-
Cable outlet	-
Degree of protection	IP20
Mechanical operation	> 100
Limiting temperature	-40°C ...+85°C
Contact material	copper alloy
Surface finishes	金
Insert material	PBT
Material of housing	zinc diecasting nickel plated

## PCB connector

Female panel mount connector,  
solder

D-Code



4pin

Contacts	screw	Designation	Order No.
4	PG9	M12-F04D-BKR-PG9-SD	163 004 324 2508
	M16x1.5	M12-F04D-BKR-M16-SD	163 004 302 4534

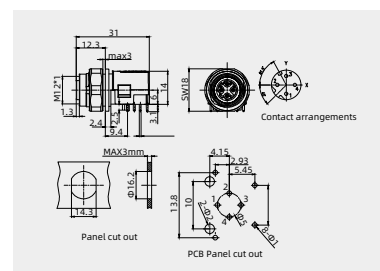

Accessories

Protection cap IP67

Protection cover  
for male cable connector



Description	Designation	Order No.
Without cord	M12-MCV	163 000 001 9003
With cord	M12-MCV/1	163 000 001 9001

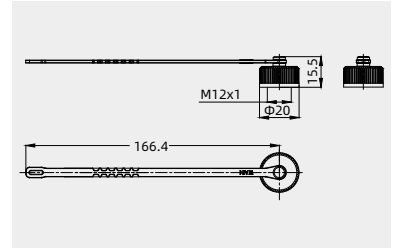

Protection cover  
for female cable connector



Description	Designation	Order No.
Without cord	M12-FCV	163 000 002 9003
With cord	M12-FCV/1	163 000 002 9001

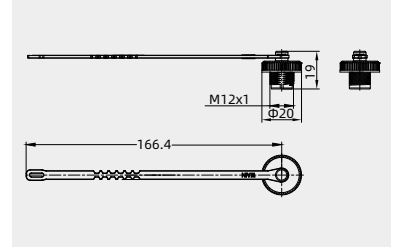

Hexagonal nut for fixing thread



screw	Designation	Order No.
PG9	WNA-PG9/S	102 105 002 1101
M16X1.5	WNA-M16/S	102 105 013 1101

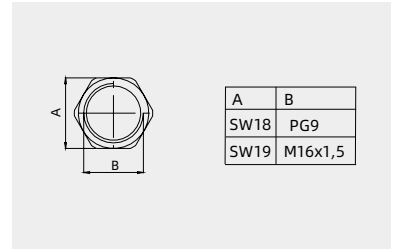



Contact arrangements

• Contact arrangements

• Male insert (mating side)

4contacts

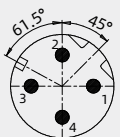

	X	Y	PROFINET	cat.5e
1	2.50	0.00	1 yellow	1 Orange white
2	0.00	2.50	2 white	2 Green and white
3	-2.50	0.00	3 orange	3 Orange
4	0.00	-2.50	4 blue	4 green

• Female insert (mating side)

4contacts



	X	Y	PROFINET	cat.5e
1	-2.50	0.00	1 yellow	1 Orange white
2	0.00	2.50	2 white	2 Green and white
3	2.50	0.00	3 orange	3 Orange
4	0.00	-2.50	4 blue	4 green

• Panel cut out

• Drilling schemes male insert (PCB), receptacles

4contacts

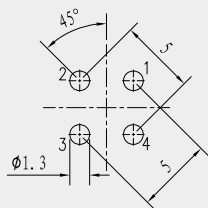

• Drilling schemes female insert (PCB), receptacles

4contacts

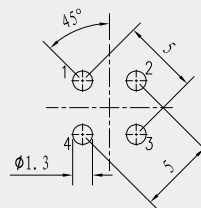

# M12-D Circular Connector

## • Panel cut out

### • Panel mount connectors

#### • Through-hole mounting

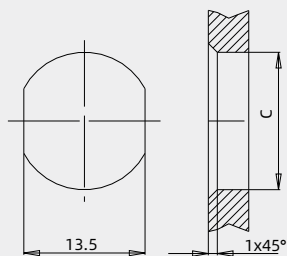

#### • Screw mounting

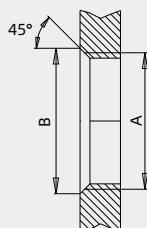

	A	B	C
PG9	PG9	16.2	15.3
PG13.5	PG13.5	21.5	20.5
M16x1.5	M16x1.5	17.0	16.1
M20x1.5	M20x1.5	21.0	20.1

Tightening torque according to DIN VDE 0619

Metal housing 6.25 Nm

Plastic housing 3.75 Nm

### • Panel mount connectors

Rear panel mounting,  
front tighten

#### • Through-hole mounting

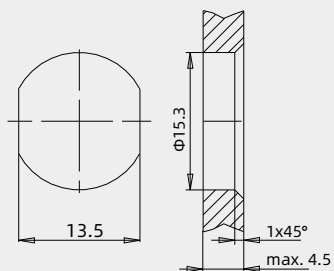

### • Panel mount connectors

front tighten

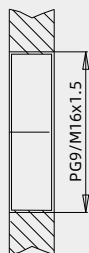

Tightening torque 6.25 Nm



M12-D

## M12 Circular Connector,S-coded



- **Cable Connector**
- crimp terminal
- Installable series and cast cable series
- M12 locking according to DIN EN 61076-2-111
- Cable length 1.5m and 5m
- Other cable length upon request, minimum order quantity 200 pieces
- Cable material can be customized according to requirements
- Protection grade IP67
- Assembled installation angle with 4 adjustable directions

## M12-S Circular Connector

630V 12A

## Technical characteristics

Number of contacts	4-pole
Rated current (40°C)	12A
Rated voltage	630V
Rated impulse voltage	6kV
Pollution degree	3
Contact resistance	≤ 3 mΩ
Connector locking system	screw M12x1
Termination	crimp
Wire gauge	max.1.5mm <sup>2</sup> (max.AWG16)
Cable outlet	4-6,6-8 mm
Degree of protection	IP67
Mechanical operation	≥ 500
Limiting temperature	-25°C ...+85°C
Material group	III
Material of contact	copper alloy
Contact plating	Au
Insulating material	PA
Material of housing	PA/PBT

## Straight cable connectors

## Male cable connector

crimp terminal,

Order crimp contacts separately



S-Code



4pin

Contacts	Cable outlet	Designation	Order No.
4(3+PE)	4-6 mm	M12-MC04S-T-D6	163 004 410 3501
	6-8 mm	M12-MC04S-T-D8	163 004 410 3500

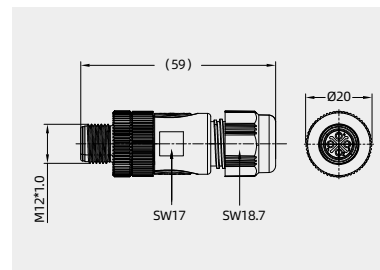

## Female cable connector

crimp terminal,

Order crimp contacts separately



S-Code



4pin

Contacts	Cable outlet	Designation	Order No.
4(3+PE)	4-6 mm	M12-FC04S-T-D6	163 004 420 3501
	6-8 mm	M12-FC04S-T-D8	163 004 420 3500

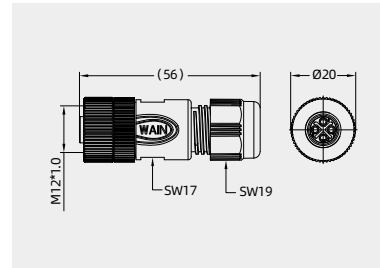

## Crimp contacts

## Crimp contacts 12A

Contact resistance ≤ 3mΩ  
gold plated

Wire gauge(mm <sup>2</sup> )	Male	Order No.
0.75-1.5	M12-MC12G-1.5	101 036 210 0950

Wire gauge(mm <sup>2</sup> )	Female	Order No.
0.75-1.5	M12-FC12G-1.5	101 036 220 0950

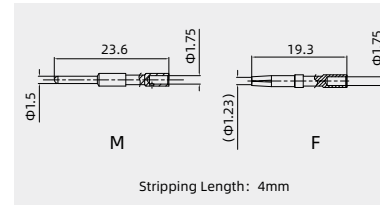

## Tools

Crimping tool



Wire gauge	Designation	Order No.
0.14-4 mm <sup>2</sup>	TL28-2	198 001 001 0039

Notes: The tools for crimp terminal may influence the product quality and stability. Please select the tools recognized by our company.

## M12-S Circular Connector

630V 12A

## Technical characteristics

Number of contacts	4-pole
Rated current (40°C)	12A
Rated voltage	630V
Rated impulse voltage	6kV
Pollution degree	3
Contact resistance	≤ 3 mΩ
Connector locking system	screw M12x1
Termination	crimp
Wire gauge	max.1.5mm <sup>2</sup> (max.AWG16)
Cable outlet	4-6,6-8 mm
Degree of protection	IP67
Mechanical operation	≥ 500
Limiting temperature	-25°C ...+85°C
Material group	III
Material of contact	copper alloy
Contact plating	Au
Insulating material	PA
Material of housing	PA/PBT

## Angled cable connectors

## Male cable connector

crimp terminal,

Order crimp contacts separately



S-Code  
  
 4pin

Contacts	Cable outlet	Designation	Order No.
4(3+PE)	4-6 mm	M12-MC04S-S-D6	163 004 510 3501
	6-8 mm	M12-MC04S-S-D8	163 004 510 3500

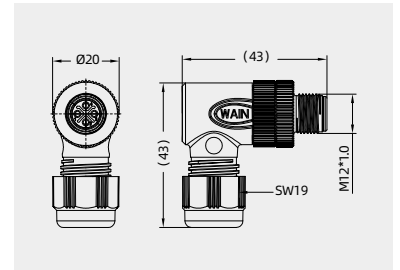

## Female cable connector

crimp terminal,

Order crimp contacts separately



S-Code  
  
 4pin

Contacts	Cable outlet	Designation	Order No.
4(3+PE)	4-6 mm	M12-FC04S-S-D6	163 004 520 3501
	6-8 mm	M12-FC04S-S-D8	163 004 520 3500

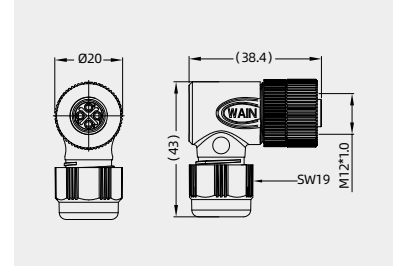

## Crimp contacts

## Crimp contacts 12A

Contact resistance ≤ 3mΩ  
gold plated

Wire gauge(mm <sup>2</sup> )	Male	Order No.
0.75-1.5	M12-MC12G-1.5	101 036 210 0950
Wire gauge(mm <sup>2</sup> )	Female	Order No.
0.75-1.5	M12-FC12G-1.5	101 036 220 0950

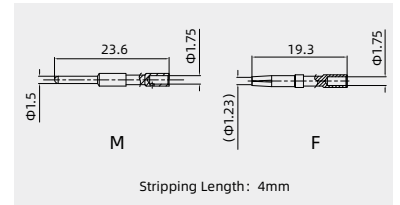

## Tools

Crimping tool



Wire gauge	Designation	Order No.
0.14-4 mm <sup>2</sup>	TL28-2	198 001 001 0039

Notes: The tools for crimp terminal may influence the product quality and stability. Please select the tools recognized by our company.

## M12-S Circular Connector

630V 12A

## Technical characteristics

Number of contacts	3-pole	4-pole
Rated current (40°C)	12A	12A
Rated voltage	630V	630V
Rated impulse voltage	6kV	6kV
Pollution degree	3	3
Contact resistance	≤ 10 mΩ	≤ 10 mΩ
Connector locking system	screw M12x1	screw M12x1
Termination	crimp, moulded	crimp, moulded
Wire gauge	max.1.5mm <sup>2</sup> (max.AWG16)	max.1.5mm <sup>2</sup> (max.AWG16)
Cable outlet	-	-
Degree of protection	IP67	IP67
Mechanical operation	> 100	> 100
Limiting temperature	-25°C ...+85°C	-25°C ...+85°C
Material group	II	II
Material of contact	copper alloy	copper alloy
Contact plating	Au	Au
Insulating material	PA	PA
Material of housing	TPU	TPU

## Straight cable connectors, cable

## Male cable connector moulded, screw



Contacts	Cable	Cable length	Designation	Order No.
3(2+PE)	3x1.5PVC	1.5 m	M12-M03S-T-1.5-PVC	163 003 410 4501
		5.0 m	M12-M03S-T-5.0-PVC	163 003 410 4502
	3x1.5PUR	1.5 m	M12-M03S-T-1.5-PUR	163 003 410 4500
		5.0 m	M12-M03S-T-5.0-PUR	163 003 410 4503
4(3+PE)	4x1.5PVC	1.5 m	M12-M04S-T-1.5-PVC	163 004 410 4504
		5.0 m	M12-M04S-T-5.0-PVC	163 004 410 4505
	4x1.5PUR	1.5 m	M12-M04S-T-1.5-PUR	163 004 410 4503
		5.0 m	M12-M04S-T-5.0-PUR	163 004 410 4506

## S-Code



## Female cable connector moulded, screw



Contacts	Cable	Cable length	Designation	Order No.
3(2+PE)	3x1.5PVC	1.5 m	M12-F03S-T-1.5-PVC	163 003 420 4502
		5.0 m	M12-F03S-T-5.0-PVC	163 003 420 4504
	3x1.5PUR	1.5 m	M12-F03S-T-1.5-PUR	163 003 420 4501
		5.0 m	M12-F03S-T-5.0-PUR	163 003 420 4503
4(3+PE)	4x1.5PVC	1.5 m	M12-F04S-T-1.5-PVC	163 004 420 4501
		5.0 m	M12-F04S-T-5.0-PVC	163 004 420 4504
	4x1.5PUR	1.5 m	M12-F04S-T-1.5-PUR	163 004 420 4500
		5.0 m	M12-F04S-T-5.0-PUR	163 004 420 4503

## S-Code

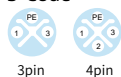

•Further cable length upon request.

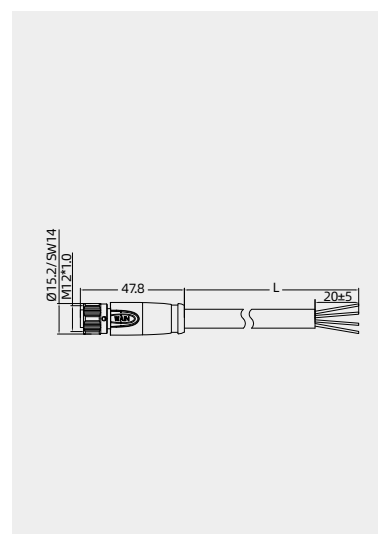
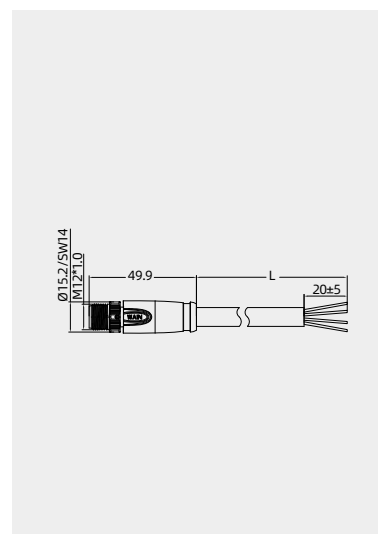

M12-S

## M12-S Circular Connector

630V 12A

## Technical characteristics

Number of contacts	3-pole	4-pole
Rated current (40°C)	12A	12A
Rated voltage	630V	630V
Rated impulse voltage	6kV	6kV
Pollution degree	3	3
Contact resistance	≤ 10 mΩ	≤ 10 mΩ
Connector locking system	screw M12x1	screw M12x1
Termination	crimp, moulded	crimp, moulded
Wire gauge	max.1.5mm <sup>2</sup> (max.AWG16)	max.1.5mm <sup>2</sup> (max.AWG16)
Cable outlet	-	-
Degree of protection	IP67	IP67
Mechanical operation	> 100	> 100
Limiting temperature	-25°C ...+85°C	-25°C ...+85°C
Material group	II	II
Material of contact	copper alloy	copper alloy
Contact plating	Au	Au
Insulating material	PA	PA
Material of housing	TPU	TPU

## Angled cable connectors, cable

Male angled connector moulded,  
screw

Contacts	Cable	Cable length	Designation	Order No.
3(2+PE)	3x1.5PVC	1.5 m	M12-M03S-S-1.5-PVC	163 003 510 4501
		5.0 m	M12-M03S-S-5.0-PVC	163 003 510 4502
	3x1.5PUR	1.5 m	M12-M03S-S-1.5-PUR	163 003 510 4500
		5.0 m	M12-M03S-S-5.0-PUR	163 003 510 4503
4(3+PE)	4x1.5PVC	1.5 m	M12-M04S-S-1.5-PVC	163 004 510 4501
		5.0 m	M12-M04S-S-5.0-PVC	163 004 510 4502
	4x1.5PUR	1.5 m	M12-M04S-S-1.5-PUR	163 004 510 4500
		5.0 m	M12-M04S-S-5.0-PUR	163 004 510 4503

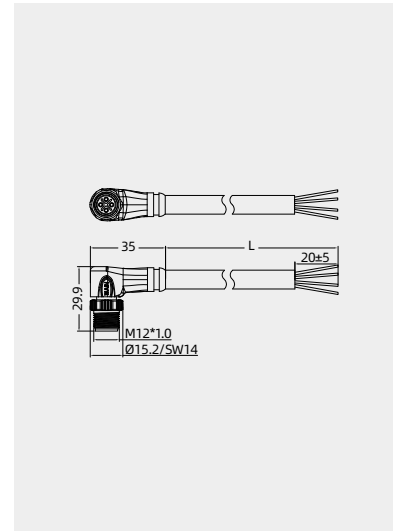

S-Code

Female angled connector moulded,  
screw

Contacts	Cable	Cable length	Designation	Order No.
3(2+PE)	3x1.5PVC	1.5 m	M12-F03S-S-1.5-PVC	163 003 520 4501
		5.0 m	M12-F03S-S-5.0-PVC	163 003 520 4503
	3x1.5PUR	1.5 m	M12-F03S-S-1.5-PUR	163 003 520 4500
		5.0 m	M12-F03S-S-5.0-PUR	163 003 520 4502
4(3+PE)	4x1.5PVC	1.5 m	M12-F04S-S-1.5-PVC	163 004 520 4501
		5.0 m	M12-F04S-S-5.0-PVC	163 004 520 4503
	4x1.5PUR	1.5 m	M12-F04S-S-1.5-PUR	163 003 520 4500
		5.0 m	M12-F04S-S-5.0-PUR	163 003 520 4502

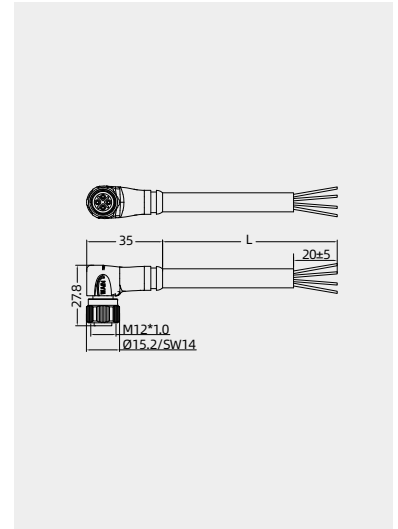

S-Code



\*Further cable length upon request.

19S-05 WAIN ELECTRICAL



## M12-S Circular Connector

630V 12A

## Technical characteristics

Number of contacts	3-pole	4-pole
Rated current (40°C)	12A	12A
Rated voltage	630V	630V
Rated impulse voltage	6kV	6kV
Pollution degree	3	3
Contact resistance	≤ 10 mΩ	≤ 10 mΩ
Connector locking system	screw M12x1	screw M12x1
Termination	single-strand wires	single-strand wires
Wire gauge	max.1.5mm <sup>2</sup> (max.AWG16)	max.1.5mm <sup>2</sup> (max.AWG16)
Cable outlet	-	-
Degree of protection	IP67	IP67
Mechanical operation	> 100	> 100
Limiting temperature	-40°C ...+85°C	-40°C ...+85°C
Material group	II	II
Material of contact	copper alloy	copper alloy
Contact plating	Au	Au
Insulating material	PA	PA
Material of housing	zinc diecasting nickel plated	zinc diecasting nickel plated

## Socket

Male panel mount connector  
with single wires, 1.5mm<sup>2</sup>  
length 0.2m



## S-Code



3pin 4pin

Contacts	screw	Designation	Order No.
3(2+PE)	PG9	M12-M03S-BK-PG9-W1.5	163 003 310 4502
	M16x1.5	M12-M03S-BK-M16-W1.5	163 003 310 4503
4(3+PE)	PG9	M12-M04S-BK-PG9-W1.5	163 004 310 4500
	M16x1.5	M12-M04S-BK-M16-W1.5	163 004 310 4501

Customized cable length upon request

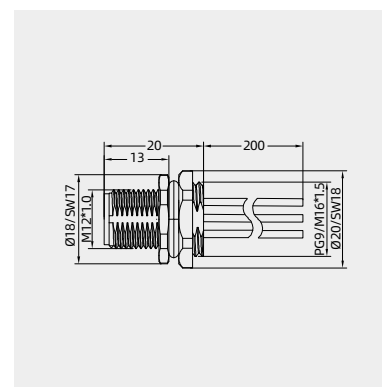

Female panel mount connector  
with single wires, 1.5mm<sup>2</sup>  
length 0.2m



## S-Code



3pin 4pin

Contacts	screw	Designation	Order No.
3(2+PE)	PG9	M12-F03S-BK-PG9-W1.5	163 003 320 4500
	M16x1.5	M12-F03S-BK-M16-W1.5	163 003 320 4501
4(3+PE)	PG9	M12-F04S-BK-PG9-W1.5	163 004 320 4501
	M16x1.5	M12-F04S-BK-M16-W1.5	163 004 320 4502

Customized cable length upon request

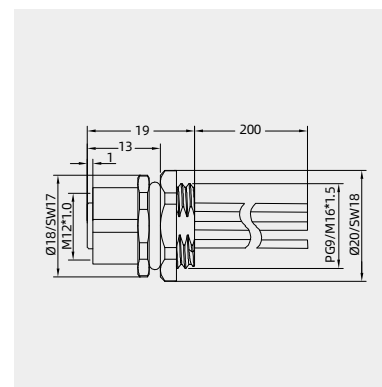

M12-S

## M12-S Circular Connector

630V 12A

## Technical characteristics

Number of contacts	3-pole	4-pole
Rated current (40°C)	12A	12A
Rated voltage	630V	630V
Rated impulse voltage	6kV	6kV
Pollution degree	3	3
Contact resistance	≤ 10 mΩ	≤ 10 mΩ
Connector locking system	solder	solder
Wire gauge	max.1.5mm <sup>2</sup> (max.AWG16)	max.1.5mm <sup>2</sup> (max.AWG16)
Cable outlet	-	-
Degree of protection	IP67	IP67
Mechanical operation	> 100	> 100
Limiting temperature	-40°C ...+85°C	-40°C ...+85°C
Material group	II	II
Material of contact	copper alloy	copper alloy
Contact plating	Au	Au
Insulating material	PA	PA
Material of housing	zinc diecasting nickel plated	zinc diecasting nickel plated

## Socket

## Male panel mount connector, solder

PG9/M16x1.5



Contacts	screw	Designation	Order No.
3(2+PE)	PG9	M12-M03S-BK-PG9-C	163 003 313 2500
	M16x1.5	M12-M03S-BK-M16-C	163 003 313 2501
4(3+PE)	PG9	M12-M04S-BK-PG9-C	163 004 313 2500
	M16x1.5	M12-M04S-BK-M16-C	163 004 313 2501

## S-Code



3pin 4pin

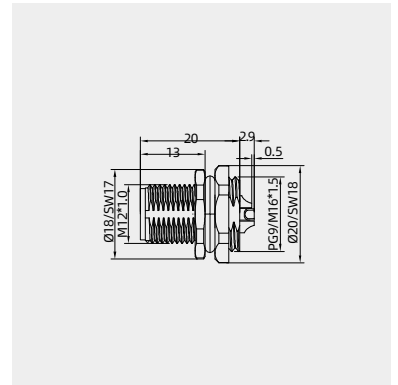

## Female panel mount connector, solder

PG9/M16x1.5



Contacts	screw	Designation	Order No.
3(2+PE)	PG9	M12-F03S-BK-PG9-C	163 003 323 2500
	M16x1.5	M12-F03S-BK-M16-C	163 003 323 2501
4(3+PE)	PG9	M12-F04S-BK-PG9-C	163 004 323 2500
	M16x1.5	M12-F04S-BK-M16-C	163 004 323 2501

## S-Code



3pin 4pin

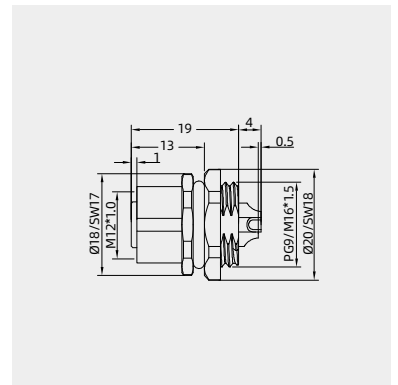

## M12-S Circular Connector

630V 12A

## Technical characteristics

Number of contacts	3-pole	4-pole
Rated current (40°C)	12A	12A
Rated voltage	630V	630V
Rated impulse voltage	6kV	6kV
Pollution degree	3	3
Contact resistance	≤ 10 mΩ	≤ 10 mΩ
Connector locking system	dip solder	dip solder
Cable outlet	-	-
Degree of protection	IP67	IP67
Mechanical operation	> 100	> 100
Limiting temperature	-40°C ...+85°C	-40°C ...+85°C
Material group	II	II
Material of contact	copper alloy	copper alloy
Contact plating	Au	Au
Insulating material	PA	PA
Material of housing	zinc diecasting nickel plated	zinc diecasting nickel plated

## Socket

Male panel mount connector, dip solder



S-Code



3pin 4pin

Contacts	screw	Designation	Order No.
3(2+PE)	PG9	M12-M03S-BK-PG9-D	163 003 314 2500
	M16x1.5	M12-M03S-BK-M16-D	163 003 314 2501
4(3+PE)	PG9	M12-M04S-BK-PG9-D	163 004 314 2500
	M16x1.5	M12-M04S-BK-M16-D	163 004 314 2501

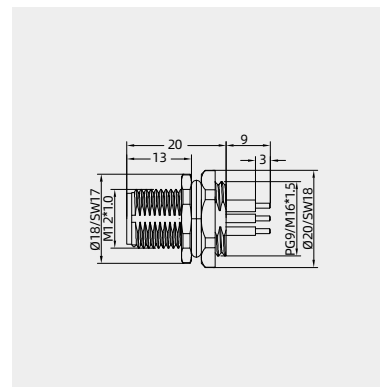

Female panel mount connector, dip solder



S-Code

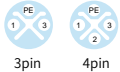

3pin 4pin

Contacts	screw	Designation	Order No.
3(2+PE)	PG9	M12-F03S-BK-PG9-D	163 003 324 2500
	M16x1.5	M12-F03S-BK-M16-D	163 003 324 2501
4(3+PE)	PG9	M12-F04S-BK-PG9-D	163 004 324 2500
	M16x1.5	M12-F04S-BK-M16-D	163 004 324 2501

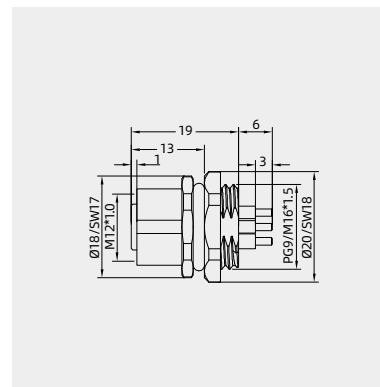

## M12-S Circular Connector

630V 12A

## Technical characteristics

Number of contacts	3-pole	4-pole
Rated current (40°C)	12A	12A
Rated voltage	630V	630V
Rated impulse voltage	6kV	6kV
Pollution degree	3	3
Contact resistance	≤ 10 mΩ	≤ 10 mΩ
Connector locking system	screw M12x1	screw M12x1
Termination	wire	wire
Wire gauge	max.1.5mm <sup>2</sup> (max.AWG16)	max.1.5mm <sup>2</sup> (max.AWG16)
Cable outlet	-	-
Degree of protection	IP67	IP67
Mechanical operation	> 100	> 100
Limiting temperature	-40°C ...+85°C	-40°C ...+85°C
Material group	II	II
Material of contact	copper alloy	copper alloy
Contact plating	Au	Au
Insulating material	PA	PA
Material of housing	zinc diecasting nickel plated	zinc diecasting nickel plated

## Socket

Male panel mount connector,  
front fastened, with single wires,  
1.5mm<sup>2</sup>/length 0.2m



## S-Code



3pin 4pin

Contacts	screw	Designation	Order No.
3(2+PE)	PG9	M12-M03S-BKR-PG9-W1.5	163 003 310 4504
	M16x1.5	M12-M03S-BKR-M16-W1.5	163 003 310 4505
4(3+PE)	PG9	M12-M04S-BKR-PG9-W1.5	163 004 310 4502
	M16x1.5	M12-M04S-BKR-M16-W1.5	163 004 310 4503

Customized cable length upon request

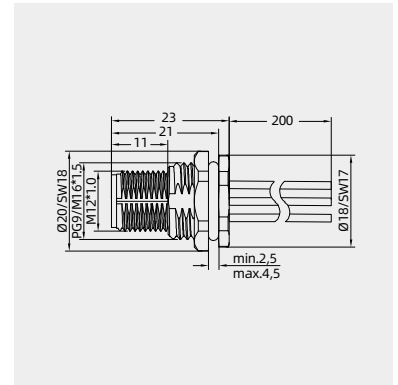

Female panel mount connector,  
front fastened, with single wires,  
1.5mm<sup>2</sup>/length 0.2m



## S-Code



3pin 4pin

Contacts	screw	Designation	Order No.
3(2+PE)	PG9	M12-F03S-BKR-PG9-W1.5	163 003 320 4502
	M16x1.5	M12-F03S-BKR-M16-W1.5	163 003 320 4503
4(3+PE)	PG9	M12-F04S-BKR-PG9-W1.5	163 004 320 4503
	M16x1.5	M12-F04S-BKR-M16-W1.5	163 004 320 4504

Customized cable length upon request

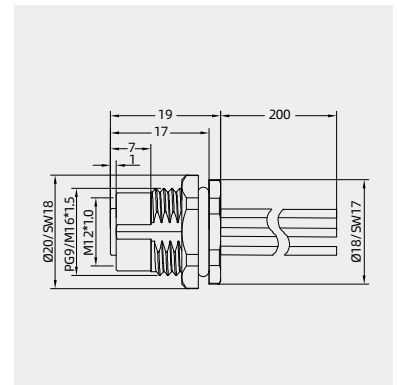

## M12-S Circular Connector

630V 12A

## Technical characteristics

Number of contacts	3-pole	4-pole
Rated current (40°C)	12A	12A
Rated voltage	630V	630V
Rated impulse voltage	6kV	6kV
Pollution degree	3	3
Contact resistance	≤ 10 mΩ	≤ 10 mΩ
Connector locking system	solder	solder
Wire gauge	max.1.5mm <sup>2</sup> (max.AWG16)	max.1.5mm <sup>2</sup> (max.AWG16)
Cable outlet	-	-
Degree of protection	IP67	IP67
Mechanical operation	> 100	> 100
Limiting temperature	-40°C ...+85°C	-40°C ...+85°C
Material group	II	II
Material of contact	copper alloy	copper alloy
Contact plating	Au	Au
Insulating material	PA	PA
Material of housing	zinc diecasting nickel plated	zinc diecasting nickel plated

## Socket

Male panel mount connector, solder

PG9/M16x1.5, front fastened



S-Code



3pin 4pin

Contacts	screw	Designation	Order No.
3(2+PE)	PG9	M12-M03S-BKR-PG9-C	163 003 313 2502
	M16x1.5	M12-M03S-BKR-M16-C	163 003 313 2503
4(3+PE)	PG9	M12-M04S-BKR-PG9-C	163 004 313 2502
	M16x1.5	M12-M04S-BKR-M16-C	163 004 313 2503

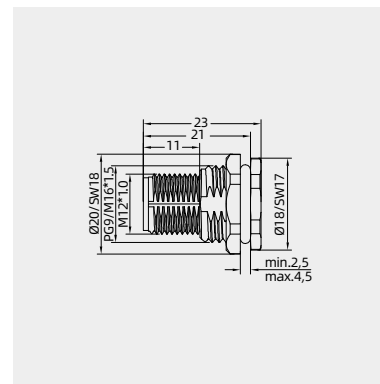

Female panel mount connector, solder

PG9/M16x1.5, front fastened



S-Code

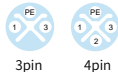

3pin 4pin

Contacts	screw	Designation	Order No.
3(2+PE)	PG9	M12-F03S-BKR-PG9-C	163 003 323 2502
	M16x1.5	M12-F03S-BKR-M16-C	163 003 323 2503
4(3+PE)	PG9	M12-F04S-BKR-PG9-C	163 004 323 2502
	M16x1.5	M12-F04S-BKR-M16-C	163 004 323 2503

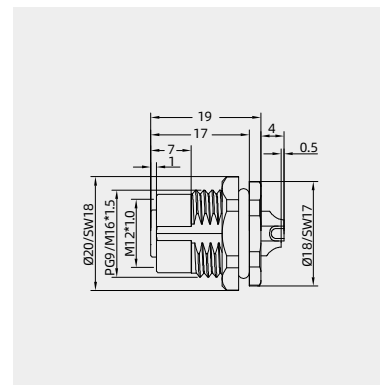

M12-S

## M12-S Circular Connector

630V 12A

## Technical characteristics

Number of contacts	3-pole	4-pole
Rated current (40°C)	12A	12A
Rated voltage	630V	630V
Rated impulse voltage	6kV	6kV
Pollution degree	3	3
Contact resistance	≤ 10 mΩ	≤ 10 mΩ
Connector locking system	dip solder	dip solder
Cable outlet	-	-
Degree of protection	IP67	IP67
Mechanical operation	> 100	> 100
Limiting temperature	-40°C ...+85°C	-40°C ...+85°C
Material group	II	II
Material of contact	copper alloy	copper alloy
Contact plating	Au	Au
Insulating material	PA	PA
Material of housing	zinc diecasting nickel plated	zinc diecasting nickel plated

## Socket

Male panel mount connector, dip solder, front fastened



S-Code



3pin 4pin

Contacts	screw	Designation	Order No.
3(2+PE)	PG9	M12-M03S-BKR-PG9-D	163 003 314 2502
	M16x1.5	M12-M03S-BKR-M16-D	163 003 314 2503
4(3+PE)	PG9	M12-M04S-BKR-PG9-D	163 004 314 2502
	M16x1.5	M12-M04S-BKR-M16-D	163 004 314 2503

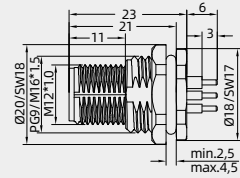

Female panel mount connector, dip solder, front fastened



S-Code



3pin 4pin

Contacts	screw	Designation	Order No.
3(2+PE)	PG9	M12-F03S-BKR-PG9-D	163 003 324 2502
	M16x1.5	M12-F03S-BKR-M16-D	163 003 324 2503
4(3+PE)	PG9	M12-F04S-BKR-PG9-D	163 004 324 2502
	M16x1.5	M12-F04S-BKR-M16-D	163 004 324 2503

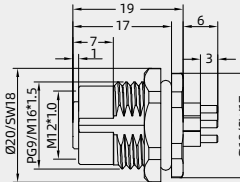

Accessories

Protection covers IP67

Protection cover  
for male cable connector



Description	Designation	Order No.
Without cord	M12-MCV	163 000 001 9003
With cord	M12-MCV/1	163 000 001 9001

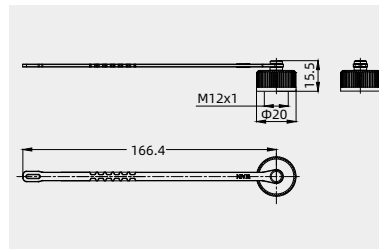

Protection cover  
for female cable connector



Description	Designation	Order No.
Without cord	M12-FCV	163 000 002 9003
With cord	M12-FCV/1	163 000 002 9001

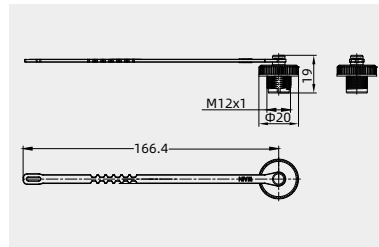

Hexagonal nut for fixing thread



screw	Designation	Order No.
PG9	WNA-PG9/S	102 105 002 1101
M16x1.5	WNA-M16/S	102 105 013 1101

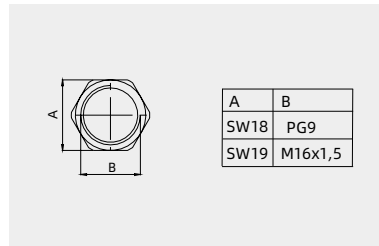

Protection covers, for flange  
mount panel



Description	Designation	Order No.
Dust-proof	M12-WNPP-M16/BK	163 000 000 9001

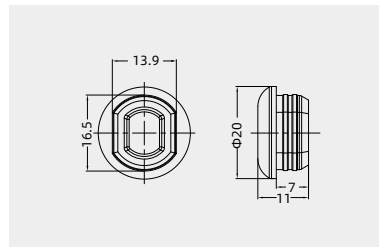

• Contact arrangements

• Male insert (mating side)

• Female insert (mating side)

3 contacts

3 contacts

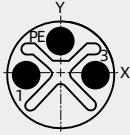

	X	Y	
1	-2.55	0.00	1. brown
3	2.55	0.00	2. blue
PE	0.00	2.55	PE. yellow green

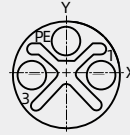

	X	Y	
1	2.55	0.00	1. brown
3	-2.55	0.00	2. blue
PE	0.00	2.55	PE. yellow green

4 contacts

4 contacts

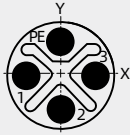

	X	Y	
1	-2.55	0.00	1. brown
2	0.00	-2.55	2. white
3	2.55	0.00	3. blue
PE	0.00	2.55	PE. yellow green

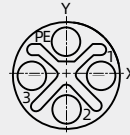

	X	Y	
1	2.55	0.00	1. brown
2	0.00	-2.55	2. white
3	-2.55	0.00	3. blue
PE	0.00	2.55	PE. yellow green



• Panel cut out

- Opening hole drawing male insert(PCB), Panel mount connectors

3 contacts

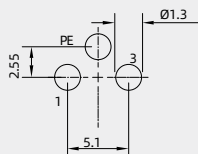

- Opening hole drawing female insert(PCB), Panel mount connectors

3 contacts

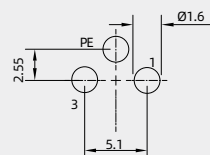

4 contacts

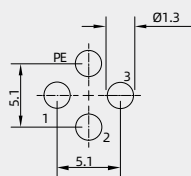

4 contacts

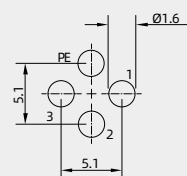

• Panel cut out

• Panel mount connectors

• Through-hole mounting

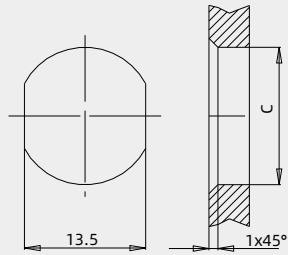

• Screw mounting

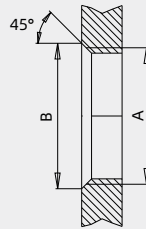

	A	B	C
PG9	PG9	16.2	15.3
PG13.5	PG13.5	21.5	20.5
M16x1.5	M16x1.5	17.0	16.1
M20x1.5	M20x1.5	21.0	20.1

Tightening torque according to DIN VDE 0619  
 Metal housing 6,25 Nm  
 Plastic housing 3,75 Nm

• Panel mount connectors

Rear panel mounting,  
 front tighten

• Through-hole mounting

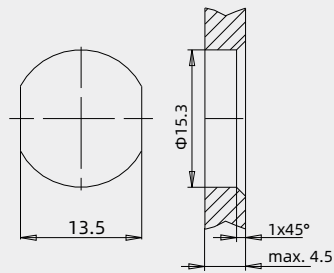

• Panel mount connectors

front tighten

• With bore hole

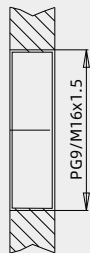

Tightening torque 6,25 Nm



## M12 circular connector,L-coded



- **Cable Connector**

- Installable series and moulded cable series
- Thread locking M12X1
- Shielding ring and ring spring shielding connection
- Cable length 1.5m and 5m
- Other cable length upon request, minimum order quantity 200 pieces
- Cable material can be customized according to requirements
- Degree of protection IP67/ IP68
- Transparent case for PCB with LED

## M12-L Circular Connector

63V 16A

## Technical characteristics

	5-pole
Rated current (40°C)	16A
Rated voltage	63V
Rated impulse voltage	1500V
Pollution degree	3
Contact resistance	≤ 10mΩ
Insulation resistance	≥ 100MQ
Connector locking system	screw M12x1
Wire gauge	0.5~2.5mm <sup>2</sup> (20~14AWG)
Degree of protection	IP67
Mechanical operation	≥ 100
Limiting temperature	-25°C ...+85°C
Insert material	PC+ABS
Contact material	copper alloy
Surface finishes	gold

## Straight cable connectors

## Male cable connector

crimp terminal,

Order crimp contacts separately



L-Code



5pin

Contacts	Cable outlet	Designation	Order No.
5	4-6 mm	M12-MC04/1L-T-D6	163 005 410 3501
	6-8 mm	M12-MC04/1L-T-D8	163 005 410 3500

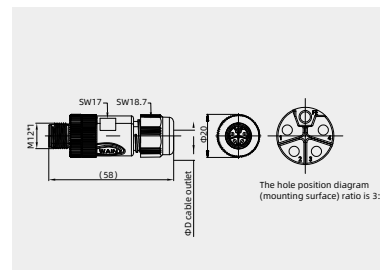

## Female cable connector

crimp terminal,

Order crimp contacts separately



L-Code



5pin

Contacts	Cable outlet	Designation	Order No.
5	4-6 mm	M12-FC04/1L-T-D6	163 005 420 3501
	6-8 mm	M12-FC04/1L-T-D8	163 005 420 3500

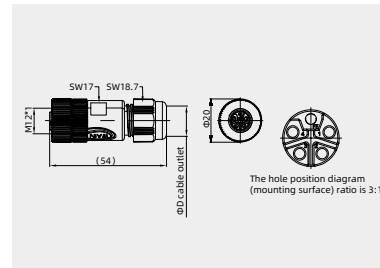

## Crimp contacts 16A

16A



NO.	Wire gauge(mm <sup>2</sup> )	Male	Order No.
①	0.5-2.5	M12-MC16G-2.5	101 019 210 1053

NO.	Wire gauge(mm <sup>2</sup> )	Female	Order No.
①	0.5-2.5	M12-FC16G-2.5	101 019 220 1053

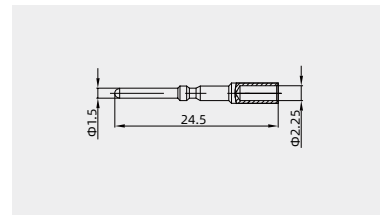

## Tools

Crimping tool



Wire gauge	Designation	Order No.
0.14-6mm <sup>2</sup>	TL02-2G	198 001 001 0014

Notes: The tools for crimp terminal may influence the product quality and stability. Please select the tools recognized by our company.

## M12-L Circular Connector

63V 16A

## Technical characteristics

	5-pole
Rated current (40°C)	16A
Rated voltage	63V
Rated impulse voltage	1500V
Pollution degree	3
Contact resistance	≤ 10mΩ
Connector locking system	screw M12x1
Termination	single-strand 2.5mm <sup>2</sup> (AWG14)
Degree of protection	IP67
Mechanical operation	≥ 100
Limiting temperature	-40°C ... +85°C
Material(Hoods/Housings)	zinc alloy
Insert material	PA
Contact material	copper alloy
Surface finishes	gold

## Straight cable connectors,cable

Male, single-strand, screw

Contacts	Cablet	Cable length	Designation	Order No.
5 (4+FE)	3X2.5PUR	1.5 m	M12-M04/1L-T-1.5-PUR	163 005 410 4501
		5.0 m	M12-M04/1L-T-5.0-PUR	163 005 410 4502

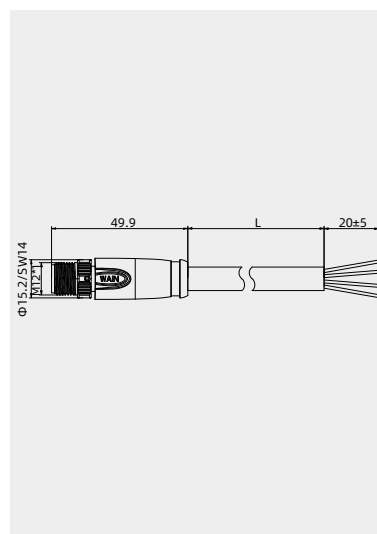

L-Code



5pin

Female, single-strand, screw

Contacts	Cablet	Cable length	Designation	Order No.
5 (4+FE)	3X2.5PUR	1.5 m	M12-F04/1L-T-1.5-PUR	163 005 420 4500
		5.0 m	M12-F04/1L-T-5.0-PUR	163 005 420 4502

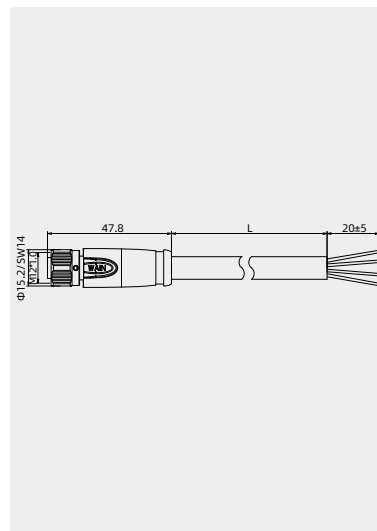

L-Code



5pin

## M12-L Circular Connector

63V 16A

## Technical characteristics

	5-pole
Rated current (40°C)	16A
Rated voltage	63V
Rated impulse voltage	1500V
Pollution degree	3
Contact resistance	≤ 10mΩ
Connector locking system	screw M12x1
Termination	single-strand 2.5mm <sup>2</sup> (AWG14)
Degree of protection	IP67
Mechanical operation	≥ 100
Limiting temperature	-40°C ... +85°C
Material(Hoods/Housings)	zinc alloy
Insert material	PA
Contact material	copper alloy
Surface finishes	gold

## Angled cable connectors

Male, single-strand, screw



L-Code



5pin

Contacts	Cablet	Cable length	Designation	Order No.
5 (4+FE)	3X2.5PUR	1.5 m	M12-M04/1L-S-1.5-PUR	163 005 510 4502
		5.0 m	M12-M04/1L-S-5.0-PUR	163 005 510 4503

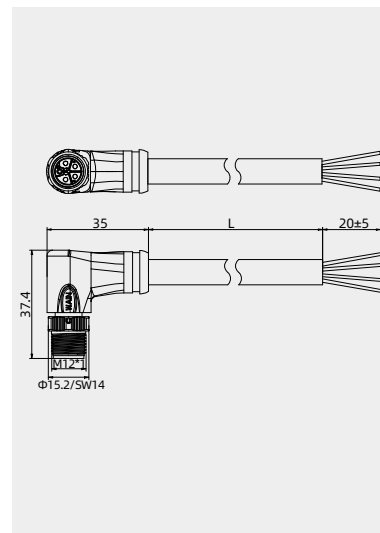

Female, single-strand, screw



L-Code



5pin

Contacts	Cablet	Cable length	Designation	Order No.
5 (4+FE)	3X2.5PUR	1.5 m	M12-F04/1L-S-1.5-PUR	163 005 520 4501
		5.0 m	M12-F04/1L-S-5.0-PUR	163 005 520 4502

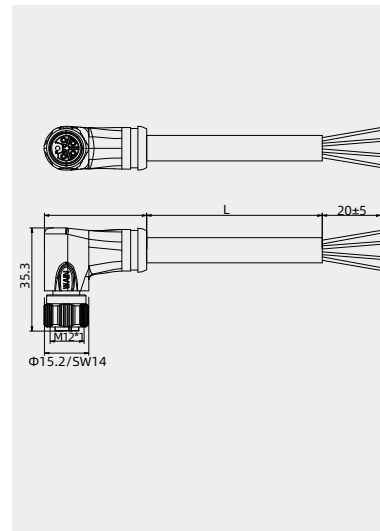

M12-L

## M12-L Circular Connector

63V 16A

## Technical characteristics

	5-pole
Rated current (40°C)	16A
Rated voltage	63V
Rated impulse voltage	1500V
Pollution degree	3
Contact resistance	≤ 10mΩ
Connector locking system	screw M12x1
Insulation resistance	≥ 10m <sup>8</sup> Ω
Degree of protection	IP27
Mechanical operation	> 100
Limiting temperature	-40°C ... +105°C
Material(Hoods/Housings)	zinc diecasting nickel plated
Insert material	PA
Contact material	copper alloy
Surface finishes	gold

## Straight cable connectors, cable

## Male, With cable connection

2.5mm<sup>2</sup>, wire length 0.2m

Contacts	screw	Designation	Order No.
5	M16x2.5	M12-M04/1L-BK-M16-W2.5	163 005 310 2500



L-Code



5pin

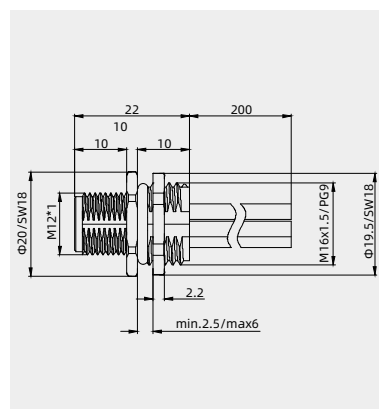

## Female, With wire connection

2.5mm<sup>2</sup>, wire length 0.2m

Contacts	screw	Designation	Order No.
5	M16x2.5	M12-F04/1L-BK-M16-W2.5	163 005 320 1501



L-Code



5pin

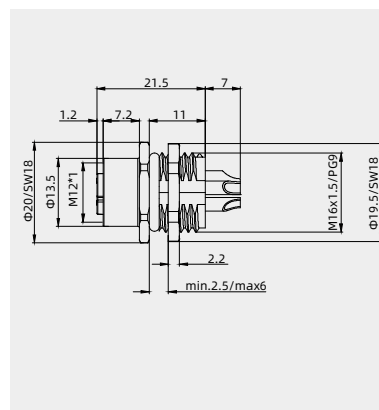



## M12-L Circular Connector

63V 16A

## Technical characteristics

	5-pole
Rated current (40°C)	16A
Rated voltage	63V
Rated impulse voltage	1500V
Pollution degree	3
Contact resistance	$\leq 10\text{m}\Omega$
Connector locking system	screw M12x1
Insulation resistance	$\geq 10\text{m}^8\Omega$
Degree of protection	IP27
Mechanical operation	> 100
Limiting temperature	-40°C ...+105°C
Material(Hoods/Housings)	zinc diecasting nickel plated
Insert material	PA
Contact material	copper alloy
Surface finishes	gold

## Straight cable connectors, cable

Male, With cable connection

2.5mm<sup>2</sup>, wire length 0.2m

L-Code



5pin

Contacts	screw	Designation	Order No.
5	M16x2.5	M12-M04/1L-BKR-M16-W2.5	163 005 310 2502

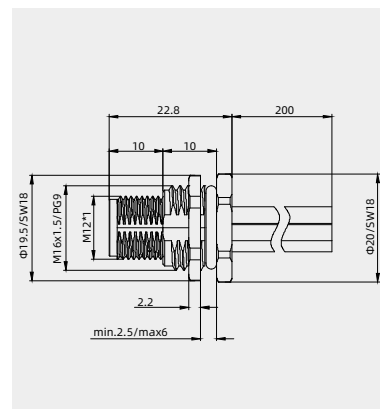

Female, With wire connection

2.5mm<sup>2</sup>, wire length 0.2m

L-Code



5pin

Contacts	screw	Designation	Order No.
5	M16x2.5	M12-F04/1L-BKR-M16-W2.5	163 005 310 2501

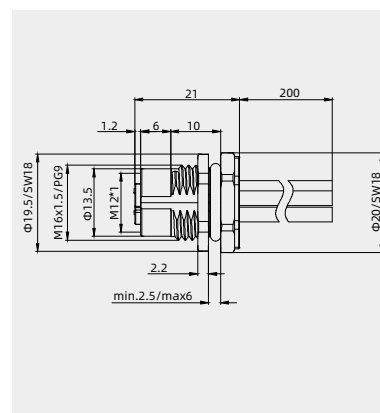

M12-L

## M12-L Circular Connector

63V 16A

## Technical characteristics

	5-pole
Rated current (40°C)	16A
Rated voltage	63V
Rated impulse voltage	1500V
Pollution degree	3
Contact resistance	≤ 10mΩ
Connector locking system	screw M12x1
Insulation resistance	≥ 10m <sup>8</sup> Ω
Degree of protection	IP27
Mechanical operation	> 100
Limiting temperature	-40°C ...+105°C
Material(Hoods/Housings)	zinc diecasting nickel plated
Insert material	PA
Contact material	copper alloy
Surface finishes	gold

## Straight cable connectors,cable

Male panel mount connector,  
solder

L-Code



5pin

Contacts	screw	Designation	Order No.
5	M16x2.5	M12-M04/1L-BK-M16-C	163 005 310 2504

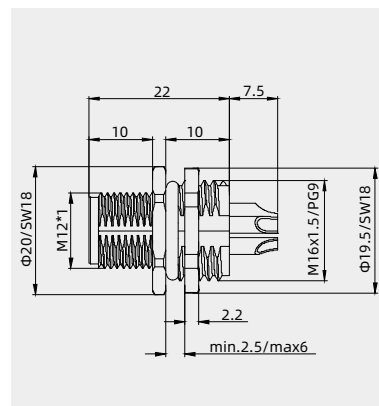

Female, Solder terminal



L-Code



5pin

Contacts	screw	Designation	Order No.
5	M16x2.5	M12-F04/1L-BK-M16-C	163 005 320 2501

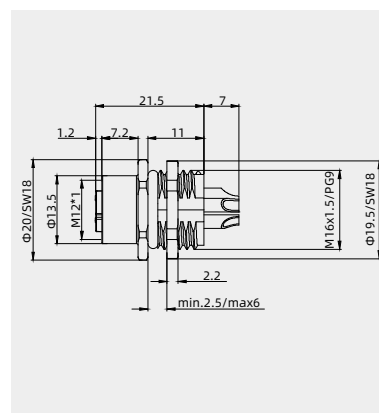

## M12-L Circular Connector

63V 16A

## Technical characteristics

	5-pole
Rated current (40°C)	16A
Rated voltage	63V
Rated impulse voltage	1500V
Pollution degree	3
Contact resistance	≤ 10mΩ
Connector locking system	screw M12x1
Insulation resistance	≥ 10m <sup>8</sup> Ω
Degree of protection	IP27
Mechanical operation	> 100
Limiting temperature	-40°C ... +105°C
Material(Hoods/Housings)	zinc diecasting nickel plated
Insert material	PA
Contact material	copper alloy
Surface finishes	gold

## Straight cable connectors,cable

Male panel mount connector,  
solder

L-Code



5pin

Contacts	screw	Designation	Order No.
5	M16x2.5	M12-M04/1L-BKR-M16-C	163 005 310 2505

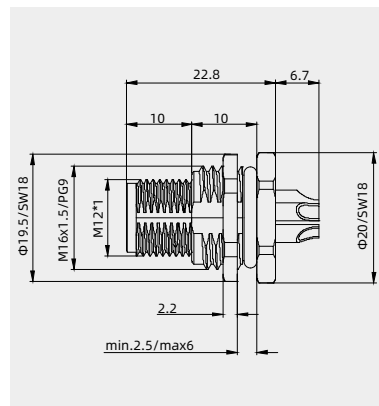

Female, Solder terminal



L-Code



5pin

Contacts	screw	Designation	Order No.
5	M16x2.5	M12-F04/1L-BKR-M16-C	163 005 320 2502

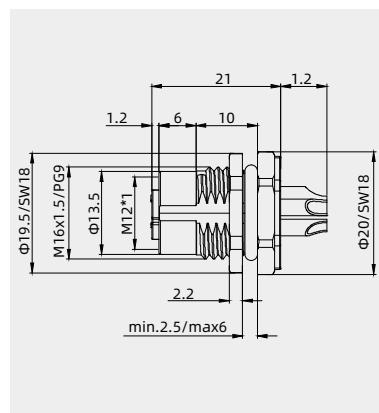

M12-L

## M12-L Circular Connector

63V 16A

## Technical characteristics

	5-pole
Rated current (40°C)	16A
Rated voltage	63V
Rated impulse voltage	1500V
Pollution degree	3
Contact resistance	≤ 10mΩ
Connector locking system	screw M12x1
Insulation resistance	≥ 10m <sup>8</sup> Ω
Degree of protection	IP27
Mechanical operation	> 100
Limiting temperature	-40°C ...+105°C
Material(Hoods/Housings)	zinc diecasting nickel plated
Insert material	PA
Contact material	copper alloy
Surface finishes	gold

## Straight cable connectors,cable

## Male, dip solder



## L-Code



5pin

Contacts	screw	Designation	Order No.
5	M16x2.5	M12-M04/1L-BK-M16-D	163 005 310 2506

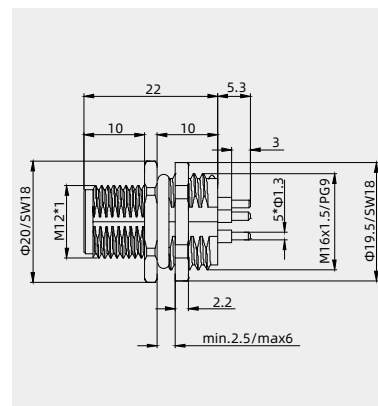

## Female, dip solder



## L-Code



5pin

Contacts	screw	Designation	Order No.
5	M16x2.5	M12-F04/1L-BK-M16-D	163 005 320 2503

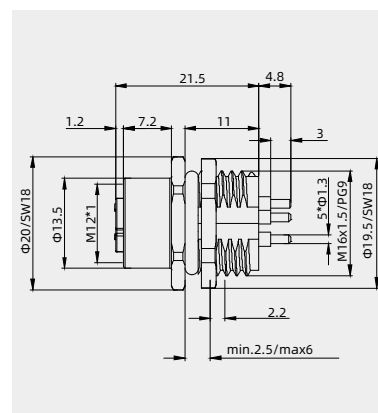

## M12-L Circular Connector

63V 16A

## Technical characteristics

	5-pole
Rated current (40°C)	16A
Rated voltage	63V
Rated impulse voltage	1500V
Pollution degree	3
Contact resistance	≤ 10mΩ
Connector locking system	screw M12x1
Insulation resistance	≥ 10m <sup>8</sup> Ω
Degree of protection	IP27
Mechanical operation	> 100
Limiting temperature	-40°C ... +105°C
Material(Hoods/Housings)	zinc diecasting nickel plated
Insert material	PA
Contact material	copper alloy
Surface finishes	gold

## Straight cable connectors,cable

## Male, dip solder



## L-Code



5pin

Contacts	screw	Designation	Order No.
5	M16x2.5	M12-M04/1L-BKR-M16-D	163 005 310 2507

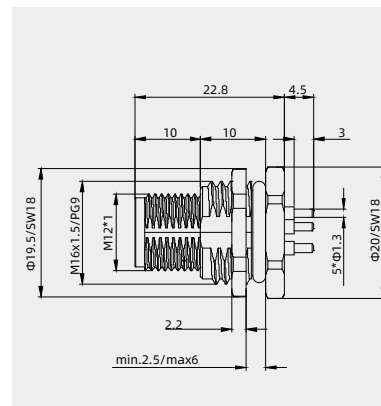

## Female, dip solder



## L-Code



5pin

Contacts	screw	Designation	Order No.
5	M16x2.5	M12-F04/1L-BKR-M16-D	163 005 320 2504

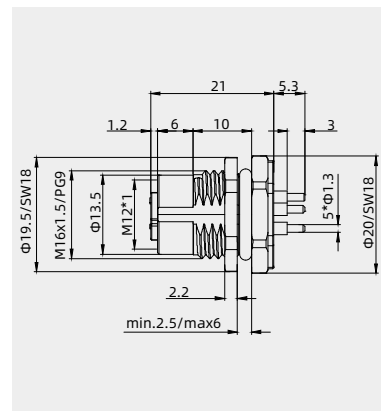

## M12 Circular Connector, X-coded



- Cable Connector
- Degree of protection IP67
- With nut locking spring
- Gigabit transmission
- Shieldable/360° shield connection
- Anti-loose spring with nut

## M12-X Circular Connector

50V/60V 0.5A

## Technical characteristics

Number of contacts	8
Rated current (40°C)	0.5A
Rated voltage	50V a.c / 60V d.c
Rated impulse voltage	0.8kV
Pollution degree	3
Contact resistance	≤ 10 mΩ
Insulation resistance	≥ 10 mΩ
Connector locking system	screw M12x1
Wire gauge	0.14mm <sup>2</sup> (AWG 26)
Degree of protection	IP67
Mechanical operation	≥ 100
Limiting temperature	-40°C ... +85°C
Material of contact	copper alloy
Contact plating	Au
Insulating material	PA
Material of housing	zinc diecasting nickel plated

## Straight cable connectors

Male cable connector, Cat.6a

Order crimp contacts separately

X-Code



Contacts	Cable outlet	Designation	Order No.
8	6-8mm	M12-MC08X-T-D8-SH	163 008 010 2001

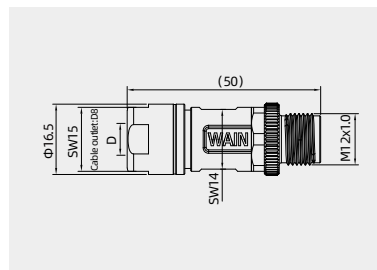

Male cable connector, Cat.6a

Order crimp contacts separately

X-Code



Contacts	Cable outlet	Designation	Order No.
8	6-8mm	M12-MC08X-CCT/R-M16-D8-SH	163 008 710 2001

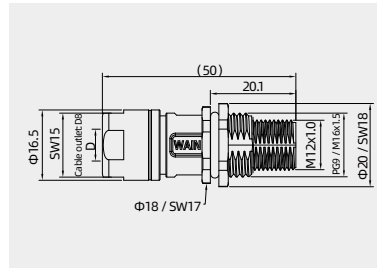

## Crimp contacts

Crimp contacts 5A

Contact resistance ≤ 3mΩ  
gold plated

Wire gauge(mm <sup>2</sup> )	Male	Order No.
0.09-0.25	M12-MC0.5G-0.25	101 038 210 0101
Wire gauge(mm <sup>2</sup> )	Female	Order No.
0.09-0.25	M12-FC0.5G-0.25	101 038 220 0101

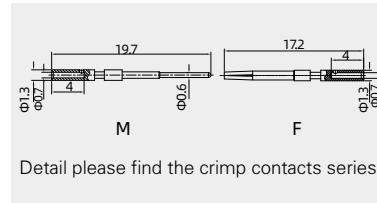

Tools

Crimping tool



Wire gauge	Designation	Order No.
0.09-0.25mm <sup>2</sup>	TL27	198 001 001 0037

Notes: The tools for crimp terminal may influence the product quality and stability. Please select the tools recognized by our company.

## M12-X Circular Connector

50V/60V 0.5A

## Technical characteristics

Number of contacts	8
Rated current (40°C)	0.5A
Rated voltage	50V a.c / 60V d.c
Rated impulse voltage	0.8kV
Pollution degree	3
Contact resistance	≤ 10 mΩ
Insulation resistance	≥ 10 mΩ
Connector locking system	screw M12x1
Wire gauge	0.14mm <sup>2</sup> (AWG 26)
Degree of protection	IP67
Mechanical operation	≥ 100
Limiting temperature	-40°C ...+85°C
Material of contact	copper alloy
Contact plating	Au
Insulating material	PA
Material of housing	zinc diecasting nickel plated

## Straight cable connectors

Female cable connector, Cat.6a

Order crimp contacts separately



X-Code



8pin

Contacts	Cable outlet	Designation	Order No.
8	6-8mm	M12-FC08X-T-D8-SH	163 008 020 0001

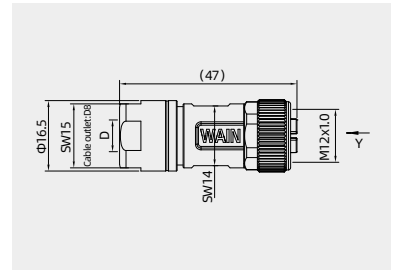

Female cable connector, Cat.6a

Order crimp contacts separately



X-Code



8pin

Contacts	Cable outlet	Designation	Order No.
8	6-8mm	M12-FC08X-CCT/R-M16-D8-SH	163 008 720 2001

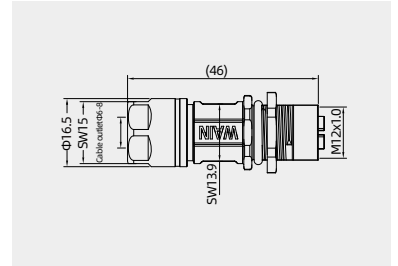

## Crimp contacts

Crimp contacts 5A

Contact resistance ≤ 3mΩ  
gold plated

Wire gauge(mm <sup>2</sup> )	Male	Order No.
0.09-0.25	M12-MC0.5G-0.25	101 038 210 0101
Wire gauge(mm <sup>2</sup> )	Female	Order No.
0.09-0.25	M12-FC0.5G-0.25	101 038 220 0101

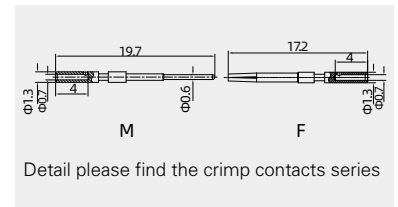

Detail please find the crimp contacts series

Tools

Crimping tool



Wire gauge	Designation	Order No.
0.09-0.25mm <sup>2</sup>	TL27	198 001 001 0037

Notes: The tools for crimp terminal may influence the product quality and stability. Please select the tools recognized by our company.



## M12-X Circular Connector

50V/60V 0.5A

## Technical characteristics

Number of contacts	8
Rated current (40°C)	0.5A
Rated voltage	50V a.c / 60V d.c
Rated impulse voltage	0.8kV
Pollution degree	3
Contact resistance	≤ 10 mΩ
Insulation resistance	≥ 10 mΩ
Connector locking system	screw M12x1
Wire gauge	0.14mm <sup>2</sup> (AWG 26)
Degree of protection	IP67
Mechanical operation	≥ 100
Limiting temperature	-40°C ... +85°C
Material of contact	copper alloy
Contact plating	Au
Insulating material	PA
Material of housing	zinc diecasting nickel plated

## Socket



Female cable connector,  
Cat.6a, shield



X-Code



8pin

Contacts	Cable outlet	Designation	Order No.
8		M12-F08X/F08X-BKR-M17	163 008 324 2501

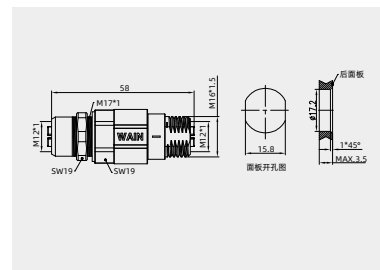

## M12-X Circular Connector

50V/60V 0.5A

## Technical characteristics

Number of contacts	8
Rated current (40°C)	0.5A
Rated voltage	50V a.c / 60V d.c
Rated impulse voltage	0.8kV
Pollution degree	3
Contact resistance	≤ 10 mΩ
Insulation resistance	≥ 10 mΩ
Connector locking system	screw M12x1
Wire gauge	0.14mm <sup>2</sup> (AWG 26)
Degree of protection	IP67
Mechanical operation	≥ 100
Limiting temperature	-40°C ...+85°C
Material of contact	copper alloy
Contact plating	Au
Insulating material	PA
Material of housing	zinc diecasting nickel plated

## Socket

Female panel mount connector , shielded



X-Code



8pin

Contacts	Cable length	screw	Designation	Order No.
8	0.5m	PG9	M12-F08X-BKR-PG9-Cat.6a	163 008 302 4003
	0.5m	M16x1.5	M12-F08X-BKR-M16-0.5-PUR-Cat.6a	163 008 302 4005

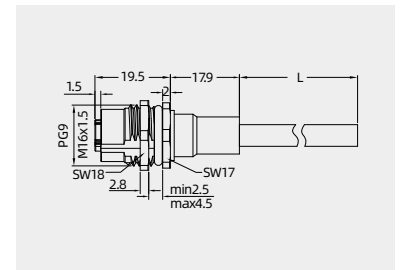

## M12-X Circular Connector

50V/60V 0.5A

## Technical characteristics

Number of contacts	8
Rated current (40°C)	0.5A
Rated voltage	50V a.c / 60V d.c
Rated impulse voltage	0.8kV
Pollution degree	3
Contact resistance	≤ 10 mΩ
Insulation resistance	≥ 10 mΩ
Connector locking system	screw M12x1
Wire gauge	0.14mm <sup>2</sup> (AWG 26)
Degree of protection	IP67
Mechanical operation	≥ 100
Limiting temperature	-40°C ...+85°C
Material of contact	copper alloy
Contact plating	Au
Insulating material	PA
Material of housing	zinc diecasting nickel plated

## Socket

Female panel mount connector ,  
shielded

X-Code



8pin

Contacts	Cable length	screw	Designation	Order No.
8	0.5m	M16x1.5	M12-F08X-BKR-M16-D	163 008 324 1004

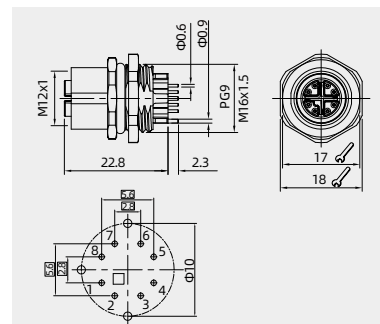

## M12-X Circular Connector

50V/60V 0.5A

## Technical characteristics

Number of contacts	8
Rated current (40°C)	0.5A
Rated voltage	50V a.c / 60V d.c
Rated impulse voltage	0.8kV
Pollution degree	3
Contact resistance	≤ 10 mΩ
Insulation resistance	≥ 10 mΩ
Connector locking system	screw M12x1
Wire gauge	0.14mm <sup>2</sup> (AWG 26)
Degree of protection	IP67
Mechanical operation	≥ 100
Limiting temperature	-40°C ...+85°C
Material of contact	copper alloy
Contact plating	Au
Insulating material	PA
Material of housing	zinc diecasting nickel plated

## Socket

Female panel mount connector , shielded



X-Code



8pin

Contacts	Cable length	screw	Designation	Order No.
8	0.5m	M16x1.5	M12-F08X-BKR-M16-W0.14	163 008 302 4006

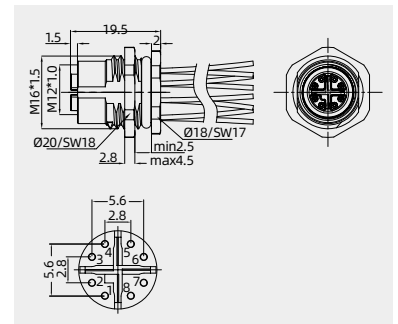

## M12-X Circular Connector

50V/60V 0.5A

## Technical characteristics

Number of contacts	8
Rated current (40°C)	0.5A
Rated voltage	50V a.c / 60V d.c
Rated impulse voltage	0.8kV
Pollution degree	3
Contact resistance	≤ 10 mΩ
Insulation resistance	≥ 10 mΩ
Connector locking system	screw M12x1
Wire gauge	0.14mm <sup>2</sup> (AWG 26)
Degree of protection	IP67
Mechanical operation	≥ 100
Limiting temperature	-40°C ...+85°C
Material of contact	copper alloy
Contact plating	Au
Insulating material	PA
Material of housing	zinc diecasting nickel plated

## Straight cable connectors, cable

## Male cable connector



X-Code



8pin

Contacts	Cable length	Designation	Order No.
8	1.5 m	M12-M08X-T-1.5-PUR-Cat.6a	163 008 401 4001
	5.0 m	M12-M08X-T-5.0-PUR-Cat.6a	163 008 401 4002

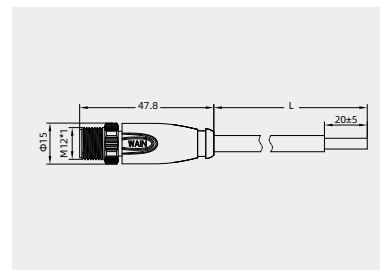

## M12-X Circular Connector

50V/60V 0.5A

## Technical characteristics

Number of contacts	8
Rated current (40°C)	0.5A
Rated voltage	50V a.c / 60V d.c
Rated impulse voltage	0.8kV
Pollution degree	3
Contact resistance	≤ 10 mΩ
Insulation resistance	≥ 10 mΩ
Connector locking system	screw M12x1
Wire gauge	0.14mm <sup>2</sup> (AWG 26)
Degree of protection	IP67
Mechanical operation	≥ 100
Limiting temperature	-40°C ... +85°C
Material of contact	copper alloy
Contact plating	Au
Insulating material	PA
Material of housing	zinc diecasting nickel plated

## Angled cable connectors

## Male cable connector



X-Code



8pin

Contacts	Cable length	Designation	Order No.
8	1.5 m	M12-M08X-S-1.5-PUR-Cat.6a	163 008 501 4001
	5.0 m	M12-M08X-S-5.0-PUR-Cat.6a	163 008 501 4002

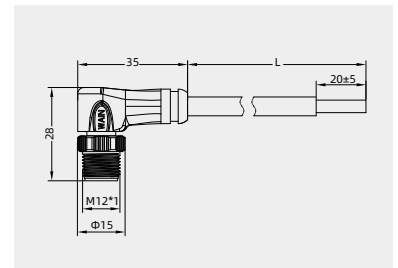

## Male cable connector



X-Code



8pin

Contacts	Cable length	Designation	Order No.
8	1.5 m	M12-F08X-T-1.5-PUR-Cat.6a	163 008 402 4541
	5.0 m	M12-F08X-T-5.0-PUR-Cat.6a	163 008 402 4542

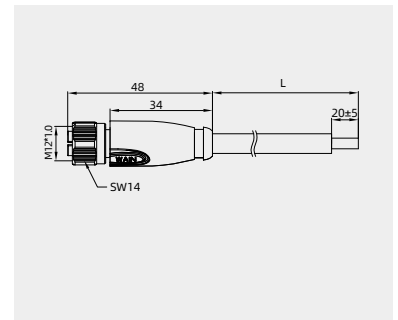

## M12-X Circular Connector

50V/60V 0.5A

## Technical characteristics

Number of contacts	8
Rated current (40°C)	0.5A
Rated voltage	50V a.c / 60V d.c
Rated impulse voltage	0.8kV
Pollution degree	3
Contact resistance	≤ 10 mΩ
Insulation resistance	≥ 10 mΩ
Connector locking system	screw M12x1
Wire gauge	0.14mm <sup>2</sup> (AWG 26)
Degree of protection	IP67
Mechanical operation	≥ 100
Limiting temperature	-40°C ...+85°C
Material of contact	copper alloy
Contact plating	Au
Insulating material	PA
Material of housing	zinc diecasting nickel plated

## Straight cable connectors, cable

## Male cable connector



## X-Code



8pin

Contacts	Cable length	Designation	Order No.
8	1.5 m	M12-M08X-T/RJ45-T-1.5-PUR-Cat.6a	163 008 402 4040
	5.0 m	M12-M08X-T/RJ45-T-5.0-PUR-Cat.6a	163 008 401 4015

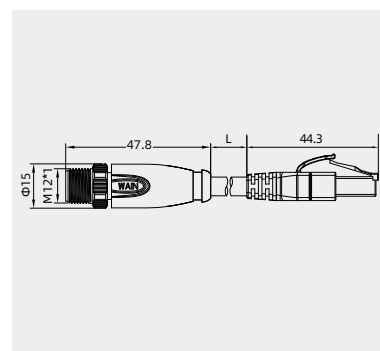

## M12-X Circular Connector

50V/60V 0.5A

### Technical characteristics

Number of contacts	8
Rated current (40°C)	0.5A
Rated voltage	50V a.c / 60V d.c
Rated impulse voltage	0.8kV
Pollution degree	3
Contact resistance	≤ 10 mΩ
Insulation resistance	≥ 10 mΩ
Connector locking system	screw M12x1
Wire gauge	0.14mm <sup>2</sup> (AWG 26)
Degree of protection	IP67
Mechanical operation	≥ 100
Limiting temperature	-40°C ... +85°C
Material of contact	copper alloy
Contact plating	Au
Insulating material	PA
Material of housing	zinc diecasting nickel plated

## Angled cable connectors

### Male cable connector



X-Code



8pin

Contacts	Cable length	Designation	Order No.
8	1.5 m	M12-M08X-S/RJ45-T-1.5-PUR-Cat.6a	163 008 001 4002
	5.0 m	M12-M08X-S/RJ45-T-5.0-PUR-Cat.6a	163 008 001 4003

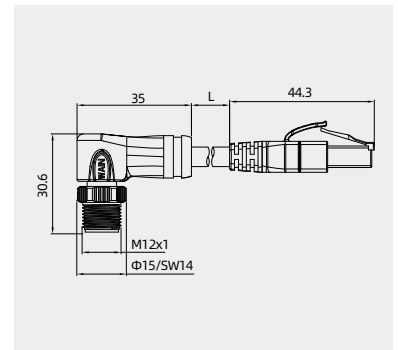

### Male cable connector



^ - Code



8pin

Contacts	Cable length	Designation	Order No.
8	1.5 m	M12-F08X-S/RJ45-T-1.5-PUR-Cat.6a	163 008 402 4543
	5.0 m	M12-F08X-S/RJ45-T-5.0-PUR-Cat.6a	163 008 402 4544

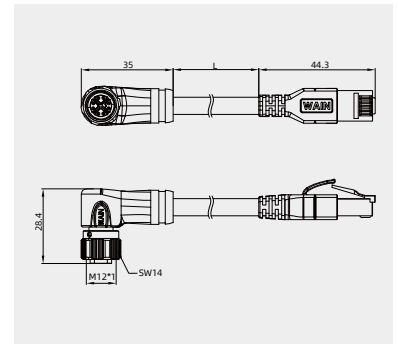



Accessories

Protection cap IP67

Protection cover  
for male cable connector



Description	Designation	Order No.
Without cord	M12-MCV	163 000 001 9003
With cord	M12-MCV/1	163 000 001 9001

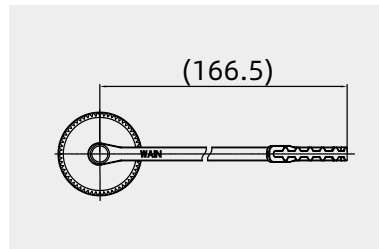

Protection cover  
for female cable connector



Description	Designation	Order No.
Without cord	M12-FCV	163 000 002 9003
With cord	M12-FCV/1	163 000 002 9001

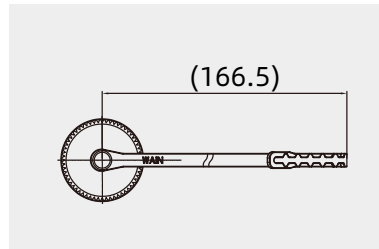

Protection covers, for flange mount  
panel



Description	Designation	Order No.
Dust-proof	M12-WNPP-M16/BK	163 000 000 9001

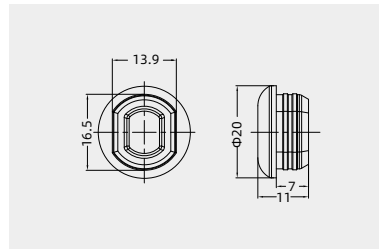

Contact arrangements

• Contact arrangements

• Male insert (mating side)

• Female insert (mating side)

8 contacts

8 contacts



	X	Y
1	1.40	-2.80
2	0.00	-1.40
3	2.80	1.40
4	1.40	2.80
5	-1.40	2.80
6	2.80	1.40
7	-2.80	-1.40
8	-1.40	-2.80

- |                |                |
|----------------|----------------|
| 568A           | 568B           |
| 1 white/green  | 1 white/Orange |
| 2 green        | 2 Orange       |
| 3 white/Orange | 3 white/green  |
| 4 Orange       | 4 green        |
| 5 white/brown  | 5 white/brown  |
| 6 brown        | 6 brown        |
| 7 white/blue   | 7 white/blue   |
| 8 blue         | 8 blue         |

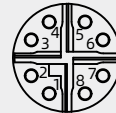

	X	Y
1	-1.40	-2.80
2	-2.80	-1.40
3	-2.80	1.40
4	-1.40	2.80
5	1.40	2.80
6	2.80	1.40
7	2.80	-1.40
8	1.40	-2.80

- |                |                |
|----------------|----------------|
| 568A           | 568B           |
| 1 white/green  | 1 white/Orange |
| 2 green        | 2 Orange       |
| 3 white/Orange | 3 white/green  |
| 4 Orange       | 4 green        |
| 5 white/brown  | 5 white/brown  |
| 6 brown        | 6 brown        |
| 7 white/blue   | 7 white/blue   |
| 8 blue         | 8 blue         |

- Opening hole drawing female insert(PCB), Panel mount connectors

8 contacts

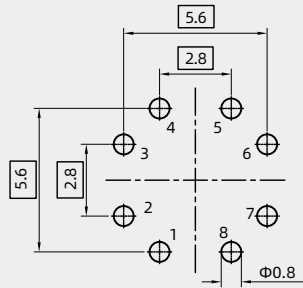

Panel cut out

• Panel mount connectors

• Through-hole mounting

• Screw mounting

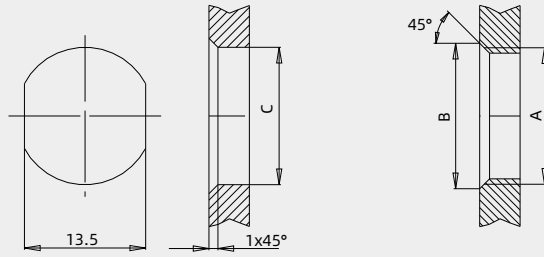

	A	B	C
PG9	PG9	16.2	15.3
PG13.5	PG13.5	21.5	20.5
M16x1.5	M16x1.5	17.0	16.1
M20x1.5	M20x1.5	21.0	20.1

Tightening torque according to DIN VDE 0619

Metal housing 6,25 Nm

Plastic housing 3,75 Nm

Panel mount connectors

Rear panel mounting,  
front tighten

• Through-hole mounting

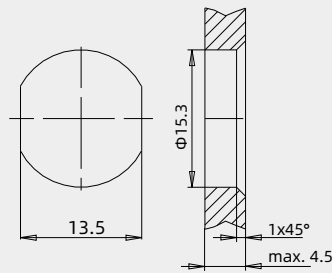

• Panel mount connectors

front tighten

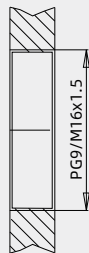

Tightening torque 6,25 Nm

PCB cut out

• Assembly instruction

- M12-MC08X-T-D8-SH
- M12-FC08X-T-D8-SH
- M12-MC08X-CCT/R-M16-D8-SH
- M12-FC08X-CCT/R-M16-D8-SH)

• Installation Step

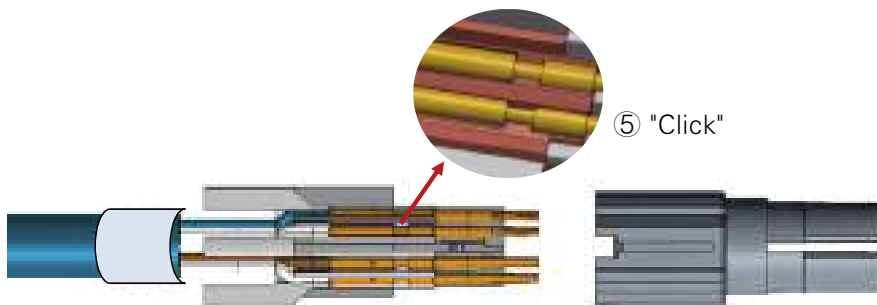
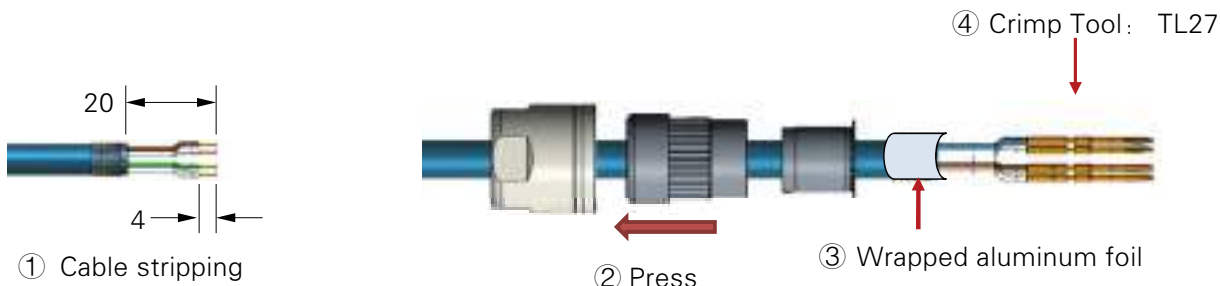

Insert the pin according to the wiring diagram



⑧ Installation complete



M12-X

## IO-LINK Sensor junction box



- IO-LINK Sensor junction box
- Bidirectional communication
- Easier installation and wiring
- Fault identification and quick recovery
- Predictive maintenance with real-time monitoring
- Simple parameter setting

## IO-LINK Sensor junction box - Master station

24V-US:16A, UA:16

## Technical Specification

Interface specification		Technical Specification	
Configuration mode	Through the main station	Bus protocol	EtherCAT, PROFINET
Power interface	2xM12, 5Pin, L-code, Red	Bus interface	2xM12, 4Pin, D-code, Blue
Power source	18~36VDC (Reverse polarity protection)	Electrical isolation	500V
U <sub>S</sub> total current	MAX 16A	Number of I / O stations	Per master
U <sub>S</sub> current consumption	≤ 100mA	Data transmission medium	More than 5 types of UTP or STP (STP recommended)
U combined current	MAX 16A	Transmission distance	≤ 100m (Station distance)
U <sub>A</sub> current consumption	0mA	Transmission rate	100Mbps
Electrical isolation between U <sub>S</sub> and U <sub>A</sub>	Yes		
Operating temperature	-25~+70°C		
Storage temperature	-40~+85°C		
Degree of protection	IP67		

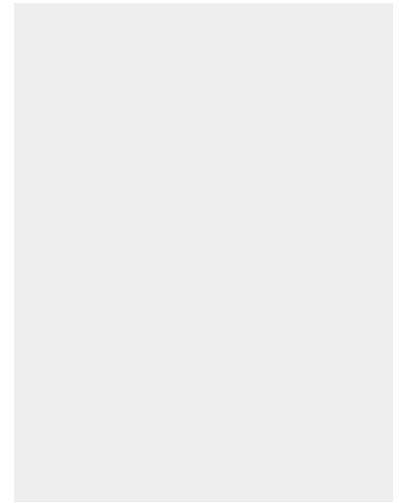

## IO-LINK Master station



Description	Designation	Order No.
EtherCAT 8xC1ass-A Port	IOL-M12-ECT-P-8A	171 058 000 3500
PROFINET 8xC1ass-A Port	IOL-M12-PFN-P-8A	171 058 000 3501

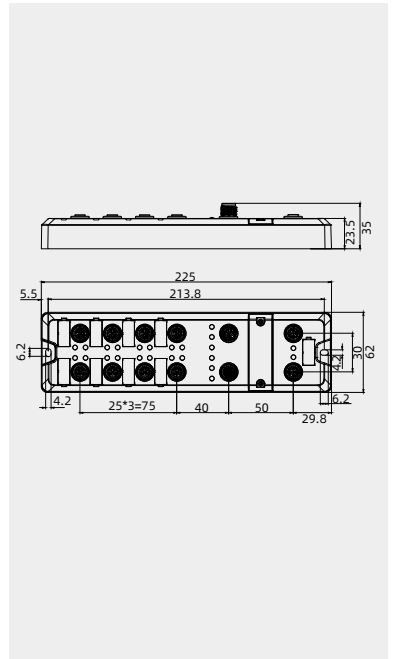

## IO-LINK Sensor junction box - Slave station

24V / Total output current 4A / Maximum output current per channel 0.5A

### Technical Specification

Technical Specification		Interface parameter	
Rated voltage	24V DC (18V~30V)	Cable length	≤ 20m (Between HUB and substation)
Input current	4mA	Communication rate	COM2 (38.4kbps)
Current loss	15mA (unloaded)	Input / output interface	M12, A-Code, 4Pin, Needle end, Red M12, A-Code, 5Pin, Hole end, Black
Input channel number	max.16	Minimum cycle time	3.2ms
Input channel type	PNP, NPN	Communication state	LED indication
Output channel number	max.16	Process data length	2 bytes
Maximum current output per channel	0.5A		
Total output current	max.4A		
Output channel type	PNP, NPN		
Storage temperature	IP67		
Degree of protection	-25°C ~+70°C		

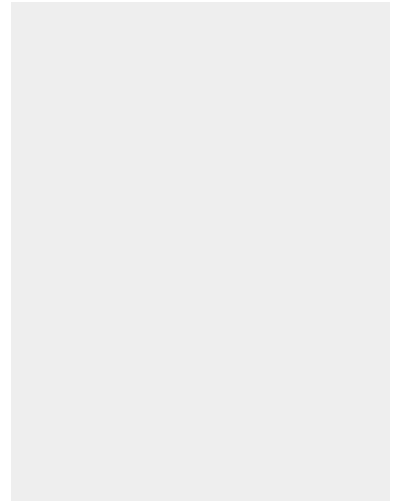

### IO-LINK Slave station



Circuit	Designation	Order No.
PNP Loop	IOL-M12-16DI-P	171 308 005 0301
	IOL-M12-16DO-P	171 308 005 0302
	IOL-M12-16C-P	171 308 005 0303
NPN Loop	IOL-M12-16C-N	171 308 005 0304

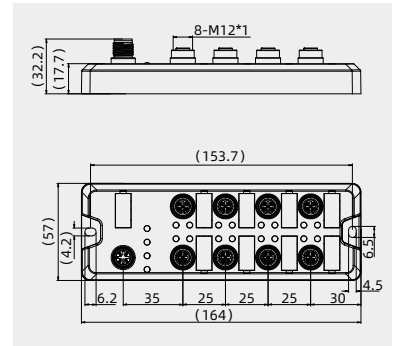



• Indicator light specification

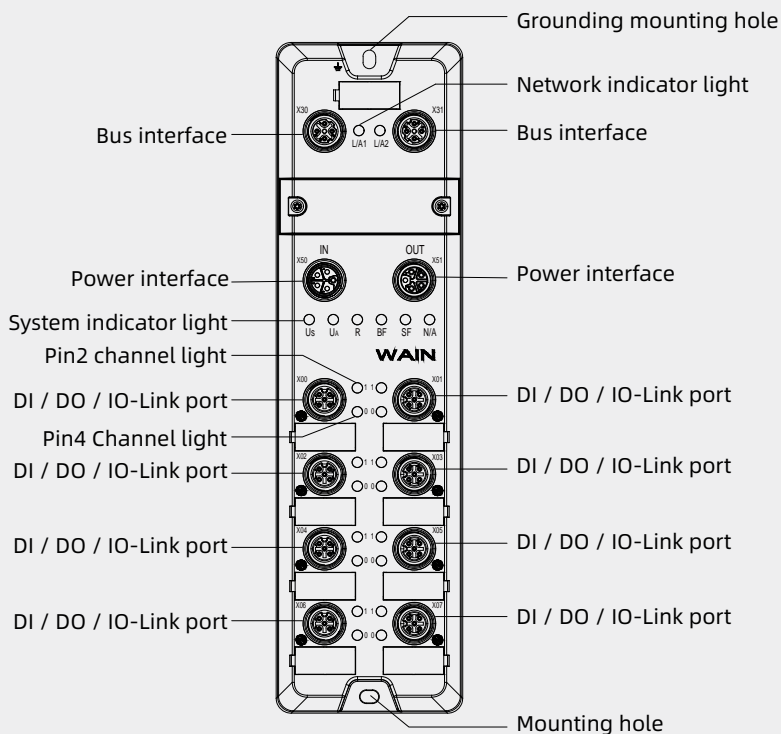

Name	Identification	Colour	State	State description
Network indicator light IN	L / A1	Green	Always on	Establish a network connection
			Flashing	Network connected with data interaction
			Off	No data interaction or abnormal
Network indicator light IN	L / A2	Green	Always on	Establish a network connection
			Flashing	Network connection and data interaction
			Off	No data interaction or exception
System power light	Us	Green	Always on	Power supply normal
			Flashing	Product not powered on or power supply error
Auxiliary power light	Ua	Green	Always on	Power supply normal
			Off	The product is not powered on or the power supply is abnormal
Running status light RUN	R	Green	Always on	Normal system operation
			Flashing	2Hz: The switch is set to Pro-OP state 1Hz: The switch is in the Safe-OP state
			Off	The device is in Init or unpowered state
Warning light (EC main station)	E	Red	Always on	System operation abnormal
			Flashing	Device offline or slave station configuration error
			Off	System operating normally or not powered on
Warning light (PN main station)	SF	Red	Always on	PROFINET master system malfunction
			Off	PROFINET master system operating normally or not powered on
	BF	Red	Always on	PROFINET master network connection error
			Off	PROFINET master network connection normal
Pin2 channel indicator	1	Green	Always on	Module channel has signal input
Pin4 channel indicator	0	Green	Always on	Module channel has high signal output or high signal input, IO-Link module operating normally
			Flashing	IO-Link module status error
			Off	Module channel has low signal output or low signal input

## IO-LINK

- Interface specification

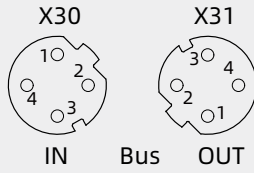

Pin	Feature
1	TX+, Data for transmission +
2	RX+, Data for reception +
3	TX-, Data for transmission -
4	RX-, Receiving data -

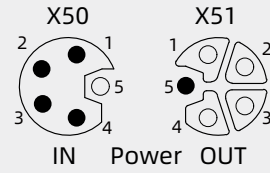

Pin	Feature	Wire colour
1	+24V U <sub>s</sub>	brown
2	0V GND <sub>A</sub>	white
3	0V GND <sub>S</sub>	blue
4	+24V U <sub>A</sub>	black
5	PE	grey

X00-X07

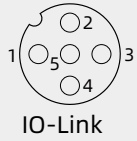

Pin	Feature	Core color
1	+24V U <sub>s</sub>	brown
2	DI/DO/+24V U	white
3	0V GND <sub>S</sub>	blue
4	DI/DO/IO-Link	black
5	PE/0V GND <sub>A</sub>	grey



# M8/M12 distributor, Sensor junction box



## Y distributor

30V 4A

### Technical characteristics

Number of contacts	4/3	4/4
Rated current (40°C)	4A	4A
Rated voltage	30V	30V
Rated impulse voltage	800V	800V
Pollution degree	3	3
Overvoltage categorie	II	II
Contact resistance	≤ 3mΩ	≤ 3mΩ
Connector locking system	screw	screw
Termination	-	-
Wire gauge	-	-
Cable outlet	-	-
Degree of protection	IP67	IP67
Mechanical operation	> 100	> 100
Limiting temperature	-25°C ...+85°C	-25°C ...+85°C
Material group	II	II
Material of contact	copper alloy	copper alloy
Contact plating	Au	Au
Insulating material	PA	PA
Material of housing	TPU	TPU

## Y distributor

Three-way, male connector M8 x 1  
- 2 female connectors M8 x 1

	Designation	Order No.
4-2*3pole	M8Y-M04/2M8-F03-NX	171 202 004 0317
4-2*4pole	M8Y-M04/2M8-F04-NX	171 202 004 0219

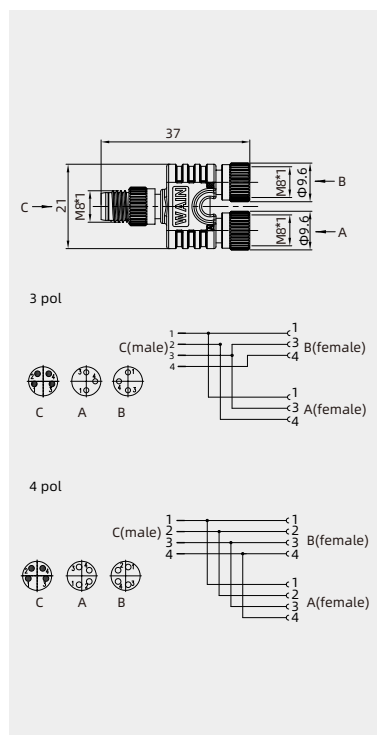

## Y distributor

60V/250V 4A

### Technical characteristics

Number of contacts	5/4	5/5
Rated current (40°C)	4A	4A
Rated voltage	250V	60V
Rated impulse voltage	2500V	1500V
Pollution degree	3	3
Overvoltage categorie	II	II
Contact resistance	≤ 10 mΩ	≤ 10 mΩ
Connector locking system	screw	screw
Termination	-	-
Wire gauge	-	-
Cable outlet	-	-
Degree of protection	IP67	IP67
Mechanical operation	> 100	> 100
Limiting temperature	-25°C ...+85°C	-25°C ...+85°C
Material group	II	II
Material of contact	copper alloy	copper alloy
Contact plating	Au	Au
Insulating material	PA	PA
Material of housing	TPU	TPU

## Y distributor

Three-way, male connector M12 x 1

- 2 female connectors M12 x 1



	Designation	Order No.
5-2*4pole	M12Y-M05A/2M12-F04A-NX	171 302 005 0318
5-2*5pole	M12Y-M05A/2M12-F05A-NX	171 302 005 0320

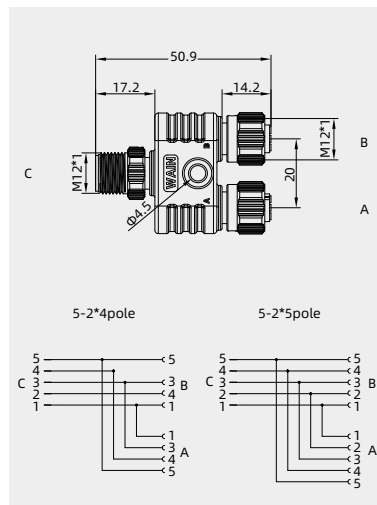

Three-way, male connector M12 x 1

- 2 female connectors M12 x 1



	Designation	Order No.
4-2*3pole	M12Y-M04A/2M8-F03-NX	163 010 000 8500

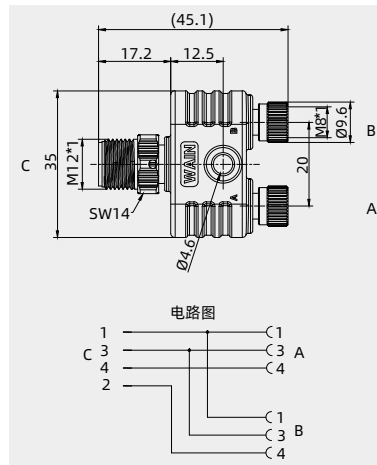

## Y distributor

60V/250V 4A

## Technical characteristics

Number of contacts	4/3	5/5
Rated current (40°C)	4A	4A
Rated voltage	250V	60V
Rated impulse voltage	2500V	1500V
Pollution degree	3	3
Overvoltage categorie	II	II
Contact resistance	≤ 10 mΩ	≤ 10 mΩ
Connector locking system	screw	screw
Termination	-	-
Wire gauge	-	-
Cable outlet	-	-
Degree of protection	IP67	IP67
Mechanical operation	> 100	> 100
Limiting temperature	-25°C ...+85°C	-25°C ...+85°C
Material group	II	II
Material of contact	copper alloy	copper alloy
Contact plating	Au	Au
Insulating material	PA	PA
Material of housing	TPU	TPU

## Y distributor

Three-way, male connector M12 x 1  
- 2 female connectors M12 x 1

	Designation	Order No.
4-2*3pole	M12Y-M04A/2M12-F03A-CX	171 302 003 0301
5-2*5pole	M12Y-M05A/2M12-F05A-CX	171 302 005 0301

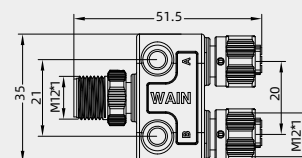

4/3 pol

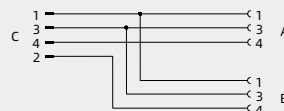

5 pol

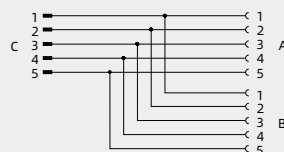

## Y distributor

60V 4A

## Technical characteristics

Number of contacts	5/5
Rated current (40°C)	4A
Rated voltage	60V
Rated impulse voltage	1500V
Pollution degree	3
Overvoltage categorie	II
Contact resistance	≤ 10 mΩ
Connector locking system	screwM12*1
Termination	-
Wire gauge	-
Cable outlet	-
Degree of protection	IP67
Mechanical operation	> 100
Limiting temperature	-25°C ...+85°C
Material group	II
Material of contact	copper alloy
Contact plating	Au
Insulating material	PA
Material of housing	TPU

## Y distributor

Three-way, male connector M12 x 1  
- 2 female connectors M12 x 1

	Designation	Order No.
5-2*5pole	M12T-M05A/2F05A-NX	163 005 000 1003

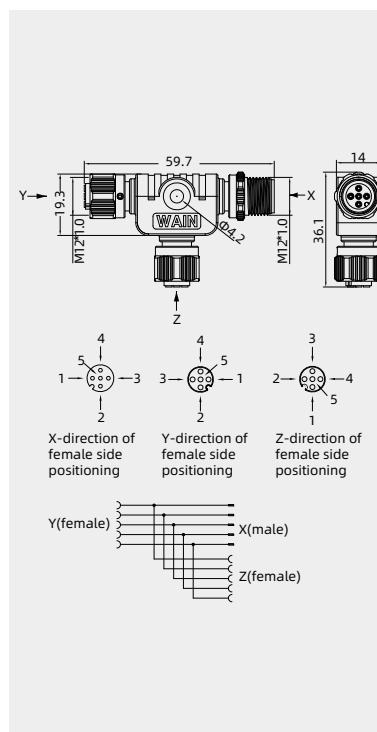



## Y distributor

60V 4A

## Technical characteristics

Number of contacts	5
Rated current (40°C)	4A
Rated voltage	60V
Rated impulse voltage	-
Pollution degree	3
Overvoltage categorie	II
Contact resistance	≤ 10 mΩ
Connector locking system	screwM12*1
Termination	-
Wire gauge	-
Cable outlet	-
Degree of protection	IP67
Mechanical operation	> 100
Limiting temperature	-25°C ...+85°C
Material group	II
Material of contact	copper alloy
Contact plating	Au
Insulating material	PA
Material of housing	TPU

## M12 Terminal resistance

Twin distributor, male connector M12x1

- 2 female connectors M12x1

	Designation	Order No.
5pole	M12-M05A-T-R120	163 005 401 4518

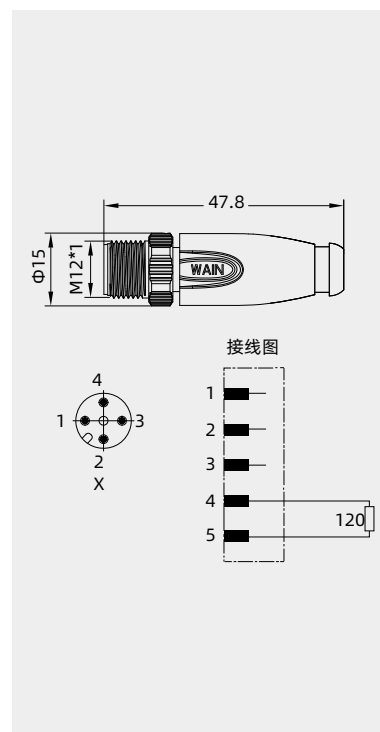

## Y distributor

60V 4A

## Technical characteristics

Number of contacts	5
Rated current (40°C)	4A
Rated voltage	60V
Rated impulse voltage	-
Pollution degree	3
Overvoltage categorie	II
Contact resistance	≤ 10 mΩ
Connector locking system	screwM12*1
Termination	-
Wire gauge	-
Cable outlet	-
Degree of protection	IP67
Mechanical operation	> 100
Limiting temperature	-25°C ...+85°C
Material group	II
Material of contact	copper alloy
Contact plating	Au
Insulating material	PA
Material of housing	TPU

## M12 Terminal resistance

Twin distributor, male connector M12x1

- 2 female connectors M12x1

	Designation	Order No.
5pole	M12-F05A-T-R120	163 005 402 4512

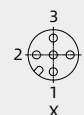
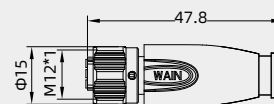

Wiring diagram

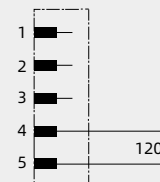

## Sensor junction box-M8

24~30V DC 2A/6A

## Technical characteristics

Number of contacts	3-pole
Rated current (40°C)	6A/2A
Rated voltage	24V~30V(max)
Rated impulse voltage	-
Pollution degree	3
Overvoltage categorie	II
Contact resistance	≤ 3 mΩ
Connector locking system	M8 x 1
Termination	electric cable
Cable outlet	Φ6-12mm
Degree of protection	IP67
Mechanical operation	> 100
Limiting temperature	-25°C ...+85°C
Material group	-
Material of contact	copper alloy
Contact plating	Au
Insulating material	PA
Material of housing	PA

## Sensor junction box-M8

## Pluggable 4-way interface box



Cable length	Circuit	Designation	Order No.
3.0m	PNP single channel	SJB-M8-4F03-3.0-PUR	171 204 003 0003

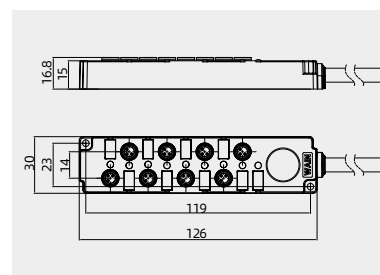

## Pluggable 8-way interface box



Cable length	Circuit	Designation	Order No.
3.0m	PNP single channel	SJB-M8-8F03-3.0-PUR	171 208 003 0003

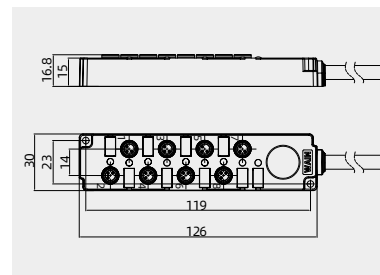

distributor

Sensor junction box-M8

- Sensor junction box-M8

- M8 4-way interface box with wire

3

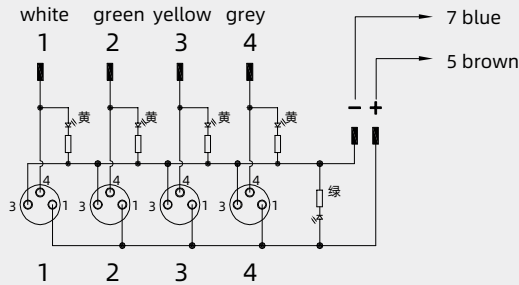

- M8 8-way interface box with wire

3

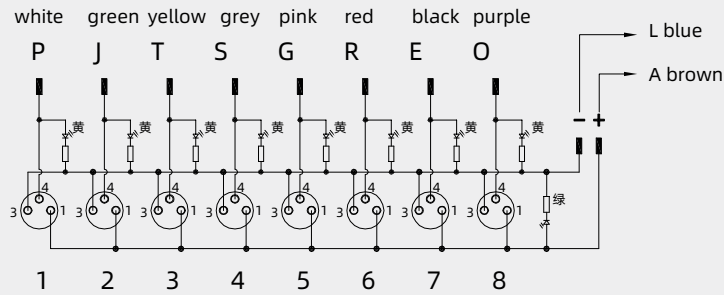

## Sensor junction box-M12

10~30V DC 2A/9A

### Technical characteristics

Number of contacts	4-pole	5-pole
Rated current (40°C)	9A/2A	9A/2A
Rated voltage	10-30V	10-30V
Rated impulse voltage	-	-
Pollution degree	3	3
Overvoltage categorie	II	II
Contact resistance	≤ 10 mΩ	≤ 10 mΩ
Connector locking system	M12 x 1	M12 x 1
Wire gauge	0.34 mm <sup>2</sup> (AWG 22)	3x0.75 mm <sup>2</sup> (AWG 20)
Cable outlet	-	-
Degree of protection	IP67	IP67
Mechanical operation	> 100	> 100
Limiting temperature	-25°C ...+80°C	-25°C ...+80°C
Material group	-	-
Material of contact	copper alloy	copper alloy
Contact plating	Au	Au
Insulating material	PBT/PA	PBT/PA
Material of housing	PA	PA

## Sensor junction box-M12

### Four-hole junction box without cable



Cable outlet	Circuit	Designation	Order No.
6-8mm	PNP single channel	SJB-M12-4F04A-D8	171 304 004 0001
8-10mm	PNP single channel	SJB-M12-4F04A-D10.5	171 304 004 0002
10-12mm	PNP single channel	SJB-M12-4F04A-D12.5	171 304 004 0003
6-8mm	PNP double channel	SJB-M12-4F05A-D8	171 304 005 0001
8-10mm	PNP double channel	SJB-M12-4F05A-D10.5	171 304 005 0002
10-12mm	PNP double channel	SJB-M12-4F05A-D12.5	171 304 005 0003

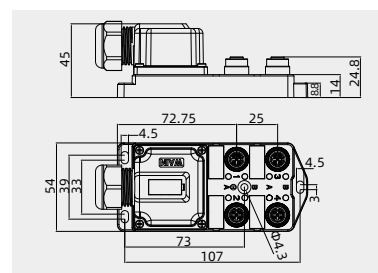

### Four-hole junction box with cable



Cable length	Circuit	Designation	Order No.
3.0m	PNP single channel	SJB-M12-4F04A-3.0-PUR	171 304 004 0004
3.0m	PNP single channel	SJB-M12-4F04A-3.0-PVC	171 304 004 0005
3.0m	PNP double channel	SJB-M12-4F05A-3.0-PUR	171 304 005 0004
3.0m	PNP double channel	SJB-M12-4F05A-3.0-PVC	171 304 005 0005

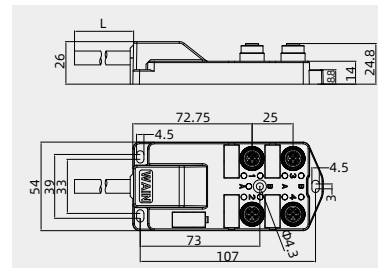

Sensor junction box-M12

• Sensor junction box-M12

• M12 4-way interface box without wire

4

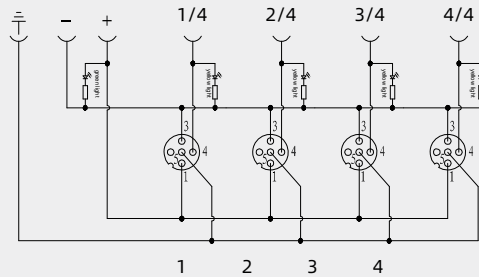

• M12 4-way interface box without wire

5

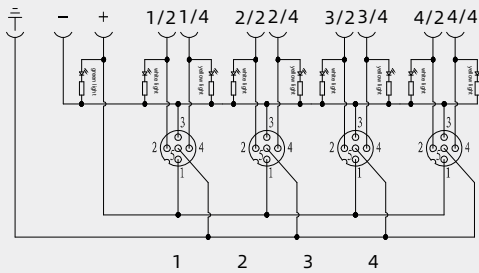

• M12 4-way interface box with wire

4

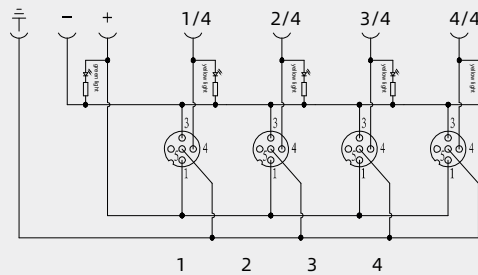

Colors of wires

- 1/4 - white
- 2/4 - green
- 3/4 - yellow
- 4/4 - grey
- (+)-brown
- (-)-blue
- (PE)-yellow/green

• M12 4-way interface box with wire

5

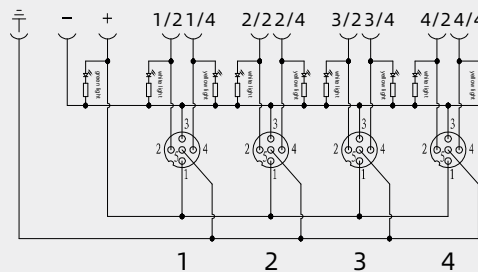

Colors of wires

- 1/2 - grey/pink
- 1/4 - white
- 2/2 - red/blue
- 2/4 - green
- 3/2 - white/green
- 3/4 - yellow
- 4/2 - brown/green
- 4/4 - grey
- (+)-brown
- (-)-blue
- (PE)-yellow/green

## Sensor junction box-M12

24~30V DC 2A/10A

## Technical characteristics

Number of contacts	4-pole	5-pole
Rated current (40°C)	总 :10A, 分线 2A	总 :10A, 分线 2A
Rated voltage	24-30V	24-30V
Rated impulse voltage	-	-
Pollution degree	3	3
Overvoltage categorie	II	II
Contact resistance	≤ 10 mΩ	≤ 10 mΩ
Connector locking system	M12 x 1	M12 x 1
Wire gauge	0.34 mm <sup>2</sup> (AWG 22),	3x0.75 mm <sup>2</sup> (AWG 20)
Cable outlet	6-12mm	6-12mm
Degree of protection	IP67	IP67
Mechanical operation	> 100	> 100
Limiting temperature	-25°C ...+80°C	-25°C ...+80°C
Material group	-	-
Material of contact	copper alloy	copper alloy
Contact plating	Au	Au
Insulating material	PBT/PA	PBT/PA
Material of housing	PA	PA

## Sensor junction box-M12

6-hole double channel junction box  
without cable

Cable outlet	Circuit	Designation	Order No.
6-8mm	PNP single channel	SJB-M12-6F04A-D8	171 306 004 0001
8-10mm	PNP single channel	SJB-M12-6F04A-D10.5	171 306 004 0002
8-10mm	PNP double channel	SJB-M12-6F05A-D10.5	171 306 005 0001
10-12mm	PNP double channel	SJB-M12-6F05A-D12.5	171 306 005 0002

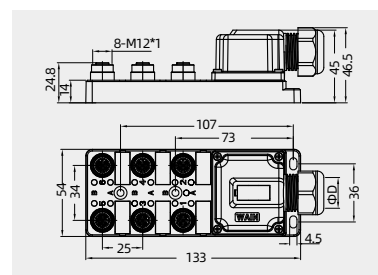
6-hole double channel junction box  
with cable

Cable length	Circuit	Designation	Order No.
3.0m	PNP single channel	SJB-M12-6F04A-3.0-PUR	171 306 004 0003
3.0m	PNP single channel	SJB-M12-6F04A-3.0-PVC	171 306 004 0004
3.0m	PNP double channel	SJB-M12-6F05A-3.0-PUR	171 306 005 0003
3.0m	PNP double channel	SJB-M12-6F05A-3.0-PVC	171 306 005 0004

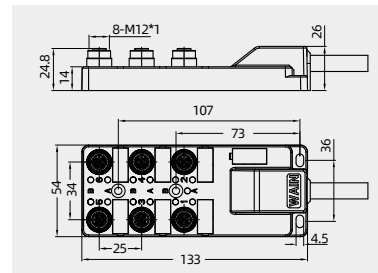

Sensor junction box-M12

• Sensor junction box-M12

• M12 6-way interface box without wire

4

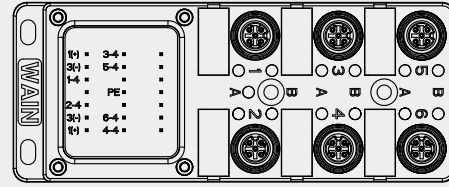
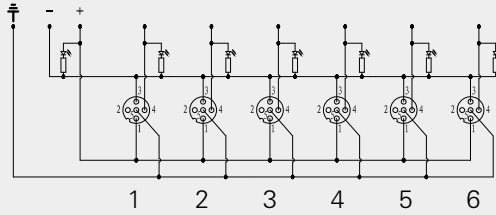

• M12 6-way interface box without wire

5

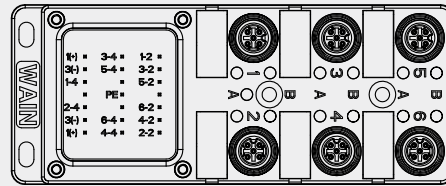
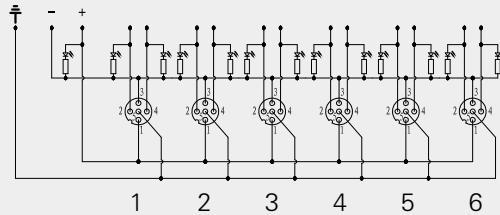

• M12 6-way interface box with wire

4

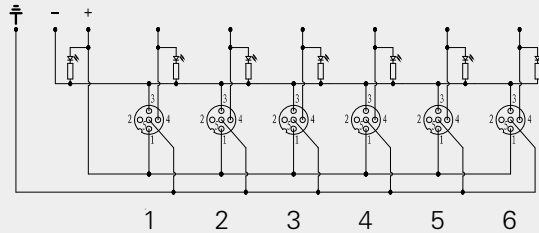

Colors of wires

- 1/4 – white
- 2/4 – green
- 3/4 – yellow
- 4/4 – grey
- 5/4 – pink
- 6/4 – red
- 1(+)-brown
- 1(-)-blue
- 5(PE)-yellow/green

• M12 6-way interface box with wire

5

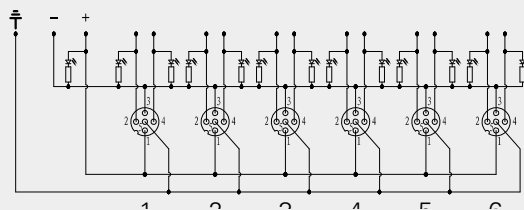

Colors of wires

- 1/2 – grey/pink
- 1/4 – white
- 2/2 – red/blue
- 2/4 – green
- 3/2 – white/green
- 3/4 – yellow
- 4/2 – brown/green
- 4/4 – grey
- 5/2 – white/yellow
- 5/4 – pink
- 6/2 – yellow/brown
- 6/4 – red
- 1(+)-brown
- 1(-)-blue
- 5(PE)-yellow/green



## Sensor junction box-M12

10~30V DC 2A/9A

### Technical characteristics

Number of contacts	4-pole	5-pole
Rated current (40°C)	9A/2A	9A/2A
Rated voltage	10-30V	10-30V
Rated impulse voltage	-	-
Pollution degree	3	3
Overvoltage categorie	II	II
Contact resistance	≤ 10 mΩ	≤ 10 mΩ
Connector locking system	M12 x 1	M12 x 1
Wire gauge	8*0.34mm <sup>2</sup> (AWG22)+3*0.75mm <sup>2</sup> (AWG18)	16*0.34mm <sup>2</sup> (AWG22)+3*0.75mm <sup>2</sup> (AWG18)
Cable outlet	-	-
Degree of protection	IP67	IP67
Mechanical operation	> 100	> 100
Limiting temperature	-25°C ...+80°C	-25°C ...+80°C
Material group	-	-
Material of contact	copper alloy	copper alloy
Contact plating	Au	Au
Insulating material	PBT/PA	PBT/PA
Material of housing	PA	PA

## Sensor junction box-M12

Pluggable 8-way interface box with M23 connector 12/19 pol, equipment-on LED (green) and functional indicator (yellow) M12 Push-Pull-locking



Cable outlet	Circuit	Designation	Order No.
M23-12pole	PNP single channel	SJB-M12-8F04-M23-12P	171 308 004 0601
M23-19pole	PNP double channel	SJB-M12-8F05A-M23-19P	171 308 005 0601

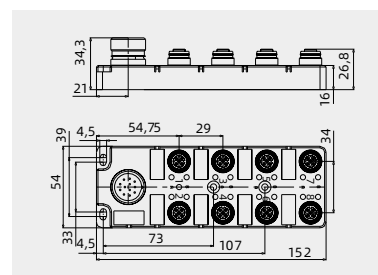

### Junction box with wire



Cable length	Circuit	Designation	Order No.
3.0m	PNP single channel	SJB-M12-8F04A-3.0-PUR	171 308 004 0001
3.0m	PNP double channel	SJB-M12-8F05A-3.0-PUR	171 308 005 0002

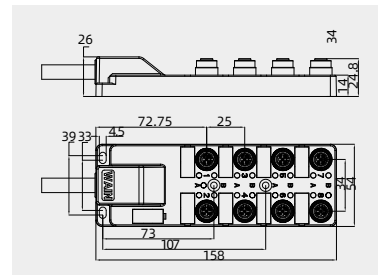

### Junction box without wire



Cable outlet	Circuit	Designation	Order No.
10-12mm	PNP single channel	SJB-M12-8F04A-D12.5	171 308 004 0002
10-12mm	PNP double channel	SJB-M12-8F05A-D12.5	171 308 005 0001

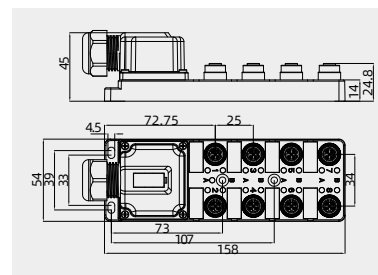

distributor

Sensor junction box-M12

• Sensor junction box-M12

• M12 8-way interface box with wire

4

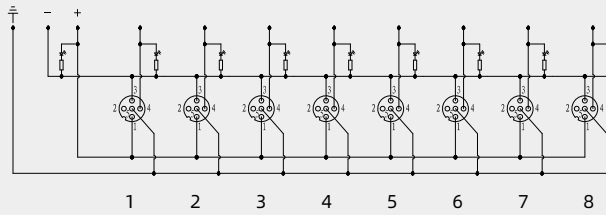

Colors of wires

- 1/4 - white
- 2/4 - green
- 3/4 - yellow
- 4/4 - grey
- 5/4 - pink
- 6/4 - red
- 7/4 - black
- 8/4 - purple
- 1(+) - brown
- 1(-) - blue
- 5(PE) - yellow/green

• M12 8-way interface box

4

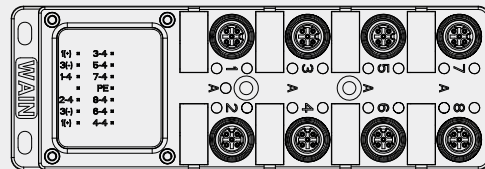
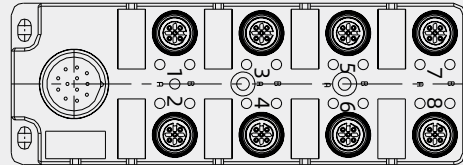
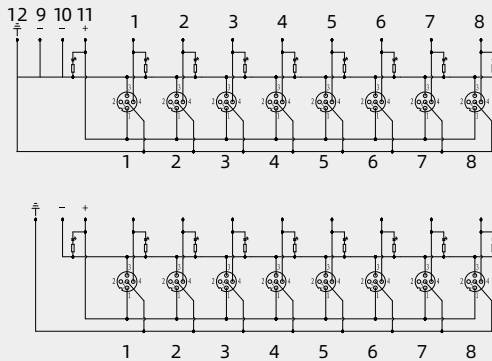

• M12 8-way interface box with wire

5

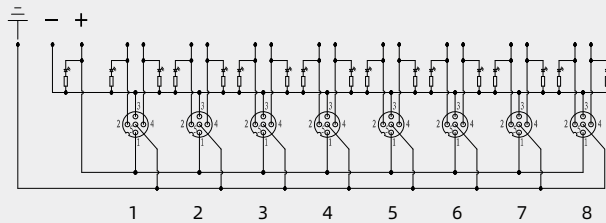

Colors of wires

- 1/2 - grey/pink
- 1/4 - white
- 2/2 - red/blue
- 2/4 - green
- 3/2 - white/green
- 3/4 - yellow
- 4/2 - blue/green
- 4/4 - grey
- 5/2 - white/yellow
- 5/4 - pink
- 6/2 - yellow/brown
- 6/4 - red
- 7/2 - white/grey
- 7/4 - black
- 8/2 - grey/brown
- 8/4 - purple
- 1(+) - brown
- 1(-) - brown
- 5(PE) - yellow/green

• M12 8-way interface box

5

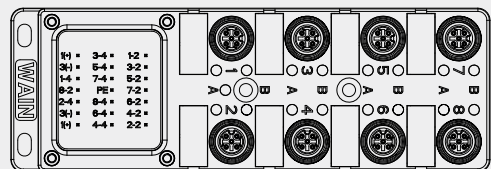
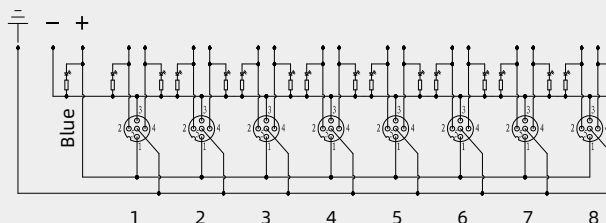



distributor

## 7/8 Circular Connector



- Panel Mount, socket/receptacle series
- 7/8-16UN Locking
- Screw Terminal
- Blocking nut constructure
- Protection Degree IP67

## 7/8 Circular Connector

300V 12/9A

## Technical characteristics

Number of contacts	3 (2+PE)	4 (3+PE)	5 (4+PE)
Rated current (40°C)	12A	9A	9A
Rated voltage	300V	300V	300V
Rated impulse voltage	4000V	4000V	4000V
Pollution degree	3	3	3
Overvoltage categorie	III	III	III
Contact resistance	≤ 3 mΩ	≤ 3 mΩ	≤ 3 mΩ
Connector locking system	screw7/8-16UN	screw7/8-16UN	screw7/8-16UN
Termination	screw	screw	screw
Wire gauge	max.1.5mm <sup>2</sup> (max.AWG16)	max.1.5mm <sup>2</sup> (max.AWG16)	max.1.5mm <sup>2</sup> (max.AWG16)
Cable outlet	6-8,8-10,10-12mm	6-8,8-10,10-12mm	6-8,8-10,10-12mm
Degree of protection	IP67	IP67	IP67
Mechanical operation	> 100	> 100	> 100
Limiting temperature	-25°C ...+85°C	-25°C ...+85°C	-25°C ...+85°C
Material group	III	III	III
Material of contact	copper alloy	copper alloy	copper alloy
Contact plating	Au	Au	Au
Insulating material	PA	PA	PA
Material of housing	PA	PA	PA

## Straight cable connectors

Male cable connector, metal locking system, screw clamp connection

Recommended use



7/8



2+PE 3+PE 4+PE

Contacts	Cable outlet	Designation	Order No.
3 (2+PE)	6-8 mm	7/8-M03-T-D8	168 003 411 3001
	8-10 mm	7/8-M03-T-D10	168 003 411 3002
	10-12mm	7/8-M03-T-D12	168 003 411 3003
4 (3+PE)	6-8 mm	7/8-M04-T-D8	168 004 411 3002
	8-10 mm	7/8-M04-T-D10	168 004 411 3001
	10-12mm	7/8-M04-T-D12	168 004 411 3003
5 (4+PE)	6-8 mm	7/8-M05-T-D8	168 005 411 3001
	8-10 mm	7/8-M05-T-D10	168 005 411 3003
	10-12mm	7/8-M05-T-D12	168 005 411 3002

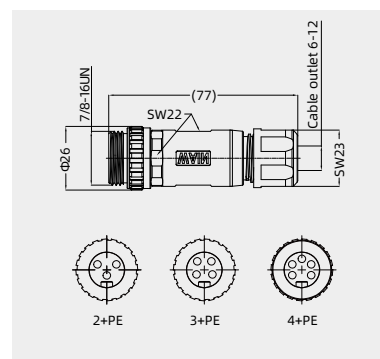

## 7/8 Circular Connector

300V 12/9A

## Technical characteristics

Number of contacts	3 (2+PE)	4 (3+PE)	5 (4+PE)
Rated current (40°C)	12A	9A	9A
Rated voltage	300V	300V	300V
Rated impulse voltage	4000V	4000V	4000V
Pollution degree	3	3	3
Overvoltage categorie	III	III	III
Contact resistance	≤ 3 mΩ	≤ 3 mΩ	≤ 3 mΩ
Connector locking system	screw7/8-16UN	screw7/8-16UN	screw7/8-16UN
Termination	screw	screw	screw
Wire gauge	max.1.5mm <sup>2</sup> (max.AWG16)	max.1.5mm <sup>2</sup> (max.AWG16)	max.1.5mm <sup>2</sup> (max.AWG16)
Cable outlet	6-8,8-10,10-12mm	6-8,8-10,10-12mm	6-8,8-10,10-12mm
Degree of protection	IP67	IP67	IP67
Mechanical operation	> 100	> 100	> 100
Limiting temperature	-25°C ...+85°C	-25°C ...+85°C	-25°C ...+85°C
Material group	III	III	III
Material of contact	copper alloy	copper alloy	copper alloy
Contact plating	Au	Au	Au
Insulating material	PA	PA	PA
Material of housing	PA	PA	PA

## Flange base cable connector

Male cable connector, metal locking system, screw clamp connection

Recommended use



7/8



2+PE

3+PE

4+PE

Contacts	Cable outlet	Designation	Order No.
3 (2+PE)	6-8 mm	7/8-M03-CCT/R-T-D8	168 003 711 3001
	8-10 mm	7/8-M03-CCT/R-T-D10	168 003 711 3002
	10-12mm	7/8-M03-CCT/R-T-D12	168 003 711 3003
4 (3+PE)	6-8 mm	7/8-M04-CCT/R-T-D8	168 004 711 3001
	8-10 mm	7/8-M04-CCT/R-T-D10	168 004 711 3002
	10-12mm	7/8-M04-CCT/R-T-D12	168 004 711 3003
5 (4+PE)	6-8 mm	7/8-M05-CCT/R-T-D8	168 005 711 3001
	8-10 mm	7/8-M05-CCT/R-T-D10	168 005 711 3002
	10-12mm	7/8-M05-CCT/R-T-D12	168 005 711 3003

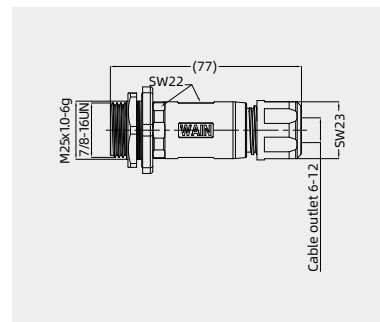

## 7/8 Circular Connector

300V 12/9A

## Technical characteristics

Number of contacts	3 (2+PE)	4 (3+PE)	5 (4+PE)
Rated current (40°C)	12A	9A	9A
Rated voltage	300V	300V	300V
Rated impulse voltage	4000V	4000V	4000V
Pollution degree	3	3	3
Overvoltage categorie	III	III	III
Contact resistance	≤ 3 mΩ	≤ 3 mΩ	≤ 3 mΩ
Connector locking system	screw7/8-16UN	screw7/8-16UN	screw7/8-16UN
Termination	screw	screw	screw
Wire gauge	max.1.5mm <sup>2</sup> (max.AWG16)	max.1.5mm <sup>2</sup> (max.AWG16)	max.1.5mm <sup>2</sup> (max.AWG16)
Cable outlet	6-8,8-10,10-12mm	6-8,8-10,10-12mm	6-8,8-10,10-12mm
Degree of protection	IP67	IP67	IP67
Mechanical operation	> 100	> 100	> 100
Limiting temperature	-25°C ...+85°C	-25°C ...+85°C	-25°C ...+85°C
Material group	III	III	III
Material of contact	copper alloy	copper alloy	copper alloy
Contact plating	Au	Au	Au
Insulating material	PA	PA	PA
Material of housing	PA	PA	PA

## Angled cable connectors

Male cable connector, metal locking system, screw clamp connection

Recommended use



7/8



2+PE

3+PE

4+PE

Contacts	Cable outlet	Designation	Order No.
3 (2+PE)	6-8 mm	7/8-M03-S-D8	168 003 511 3001
	8-10 mm	7/8-M03-S-D10	168 003 511 3002
	10-12mm	7/8-M03-S-D12	168 003 511 3003
4 (3+PE)	6-8 mm	7/8-M04-S-D8	168 004 511 3001
	8-10 mm	7/8-M04-S-D10	168 004 511 3002
	10-12mm	7/8-M04-S-D12	168 004 511 3003
5 (4+PE)	6-8 mm	7/8-M05-S-D8	168 005 511 3001
	8-10 mm	7/8-M05-S-D10	168 005 511 3002
	10-12mm	7/8-M05-S-D12	168 005 511 3003

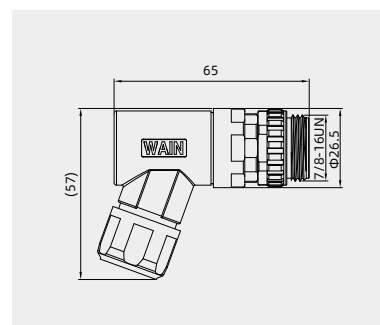

## 7/8 Circular Connector

300V 12/9A

## Technical characteristics

Number of contacts	3 (2+PE)	4 (3+PE)	5 (4+PE)
Rated current (40°C)	12A	9A	9A
Rated voltage	300V	300V	300V
Rated impulse voltage	4000V	4000V	4000V
Pollution degree	3	3	3
Overvoltage categorie	III	III	III
Contact resistance	≤ 3 mΩ	≤ 3 mΩ	≤ 3 mΩ
Connector locking system	screw7/8-16UN	screw7/8-16UN	screw7/8-16UN
Termination	screw	screw	screw
Wire gauge	max.1.5mm <sup>2</sup> (max.AWG16)	max.1.5mm <sup>2</sup> (max.AWG16)	max.1.5mm <sup>2</sup> (max.AWG16)
Cable outlet	6-8,8-10,10-12mm	6-8,8-10,10-12mm	6-8,8-10,10-12mm
Degree of protection	IP67	IP67	IP67
Mechanical operation	> 100	> 100	> 100
Limiting temperature	-25°C ...+85°C	-25°C ...+85°C	-25°C ...+85°C
Material group	III	III	III
Material of contact	copper alloy	copper alloy	copper alloy
Contact plating	Au	Au	Au
Insulating material	PA	PA	PA
Material of housing	PA	PA	PA

## Straight cable connectors

Female cable connector, metal locking system, screw clamp connection

Recommended use



7/8



2+PE 3+PE 4+PE

Contacts	Cable outlet	Designation	Order No.
3 (2+PE)	6-8 mm	7/8-F03-T-D8	168 003 421 3001
	8-10 mm	7/8-F03-T-D10	168 003 421 3002
	10-12mm	7/8-F03-T-D12	168 003 421 3003
4 (3+PE)	6-8 mm	7/8-F04-T-D8	168 004 421 3002
	8-10 mm	7/8-F04-T-D10	168 004 421 3001
	10-12mm	7/8-F04-T-D12	168 004 421 3003
5 (4+PE)	6-8 mm	7/8-F05-T-D8	168 005 421 3003
	8-10 mm	7/8-F05-T-D10	168 005 421 3001
	10-12mm	7/8-F05-T-D12	168 005 421 3002

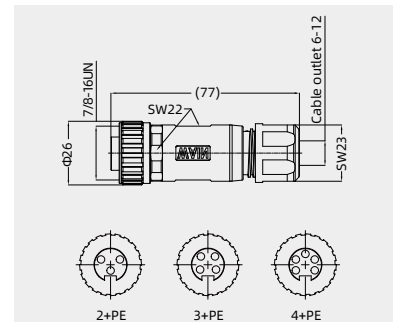



## 7/8 Circular Connector

300V 12/9A

## Technical characteristics

Number of contacts	3 (2+PE)	4 (3+PE)	5 (4+PE)
Rated current (40°C)	12A	9A	9A
Rated voltage	300V	300V	300V
Rated impulse voltage	4000V	4000V	4000V
Pollution degree	3	3	3
Overvoltage categorie	III	III	III
Contact resistance	≤ 3 mΩ	≤ 3 mΩ	≤ 3 mΩ
Connector locking system	screw7/8-16UN	screw7/8-16UN	screw7/8-16UN
Termination	screw	screw	screw
Wire gauge	max.1.5mm <sup>2</sup> (max.AWG16)	max.1.5mm <sup>2</sup> (max.AWG16)	max.1.5mm <sup>2</sup> (max.AWG16)
Cable outlet	6-8,8-10,10-12mm	6-8,8-10,10-12mm	6-8,8-10,10-12mm
Degree of protection	IP67	IP67	IP67
Mechanical operation	> 100	> 100	> 100
Limiting temperature	-25°C ...+85°C	-25°C ...+85°C	-25°C ...+85°C
Material group	III	III	III
Material of contact	copper alloy	copper alloy	copper alloy
Contact plating	Au	Au	Au
Insulating material	PA	PA	PA
Material of housing	PA	PA	PA

## Flange base cable connector

Female cable connector, metal locking system, screw clamp connection

Recommended use



7/8



2+PE

3+PE

4+PE

Contacts	Cable outlet	Designation	Order No.
3 (2+PE)	6-8 mm	7/8-F03-CCT/R-T-D8	168 003 721 3001
	8-10 mm	7/8-F03-CCT/R-T-D10	168 003 721 3002
	10-12mm	7/8-F03-CCT/R-T-D12	168 003 721 3003
4 (3+PE)	6-8 mm	7/8-F04-CCT/R-T-D8	168 004 721 3001
	8-10 mm	7/8-F04-CCT/R-T-D10	168 004 721 3002
	10-12mm	7/8-F04-CCT/R-T-D12	168 004 721 3003
5 (4+PE)	6-8 mm	7/8-F05-CCT/R-T-D8	168 005 721 3001
	8-10 mm	7/8-F05-CCT/R-T-D10	168 005 721 3002
	10-12mm	7/8-F05-CCT/R-T-D12	168 005 721 3003

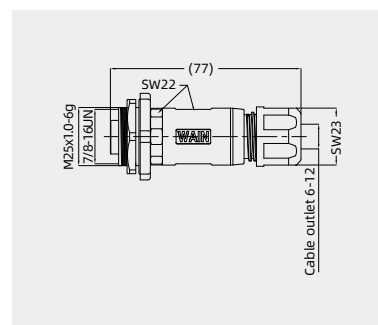

## 7/8 Circular Connector

300V 12/9A

## Technical characteristics

Number of contacts	3 (2+PE)	4 (3+PE)	5 (4+PE)
Rated current (40°C)	12A	9A	9A
Rated voltage	300V	300V	300V
Rated impulse voltage	4000V	4000V	4000V
Pollution degree	3	3	3
Overvoltage categorie	III	III	III
Contact resistance	≤ 3 mΩ	≤ 3 mΩ	≤ 3 mΩ
Connector locking system	screw7/8-16UN	screw7/8-16UN	screw7/8-16UN
Termination	screw	screw	screw
Wire gauge	max.1.5mm <sup>2</sup> (max.AWG16)	max.1.5mm <sup>2</sup> (max.AWG16)	max.1.5mm <sup>2</sup> (max.AWG16)
Cable outlet	6-8,8-10,10-12mm	6-8,8-10,10-12mm	6-8,8-10,10-12mm
Degree of protection	IP67	IP67	IP67
Mechanical operation	> 100	> 100	> 100
Limiting temperature	-25°C ...+85°C	-25°C ...+85°C	-25°C ...+85°C
Material group	III	III	III
Material of contact	copper alloy	copper alloy	copper alloy
Contact plating	Au	Au	Au
Insulating material	PA	PA	PA
Material of housing	PA	PA	PA

## Angled cable connectors

Female cable connector, metal locking system, screw clamp connection

Recommended use



7/8



2+PE

3+PE

4+PE

Contacts	Cable outlet	Designation	Order No.
3 (2+PE)	6-8 mm	7/8-F03-S-D8	168 003 521 3001
	8-10 mm	7/8-F03-S-D10	168 003 521 3002
	10-12mm	7/8-F03-S-D12	168 003 521 3003
4 (3+PE)	6-8 mm	7/8-F04-S-D8	168 004 521 3001
	8-10 mm	7/8-F04-S-D10	168 004 521 3002
	10-12mm	7/8-F04-S-D12	168 004 521 3003
5 (4+PE)	6-8 mm	7/8-F05-S-D8	168 005 521 3001
	8-10 mm	7/8-F05-S-D10	168 005 521 3002
	10-12mm	7/8-F05-S-D12	168 005 521 3003

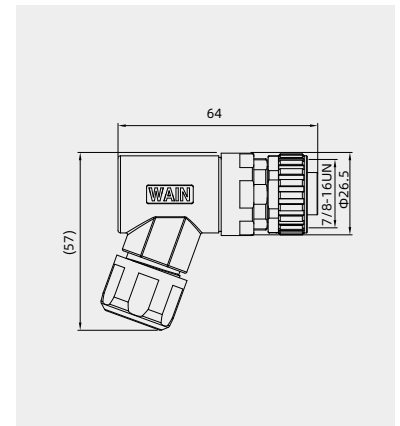

## 7/8 Circular Connector

300V 12/9A

## Technical characteristics

Number of contacts	3 (2+PE)	4 (3+PE)	5 (4+PE)
Rated current (40°C)	12A	9A	9A
Rated voltage	300V	300V	300V
Rated impulse voltage	4000V	4000V	4000V
Pollution degree	3	3	3
Overvoltage categorie	III	III	III
Contact resistance	≤ 3 mΩ	≤ 3 mΩ	≤ 3 mΩ
Connector locking system	screw7/8-16UN	screw7/8-16UN	screw7/8-16UN
Termination	screw	screw	screw
Wire gauge	max.1.5mm <sup>2</sup> (max.AWG16)	max.1.5mm <sup>2</sup> (max.AWG16)	max.1.5mm <sup>2</sup> (max.AWG16)
Degree of protection	IP67	IP67	IP67
Mechanical operation	> 100	> 100	> 100
Limiting temperature	-25°C ...+85°C	-25°C ...+85°C	-25°C ...+85°C
Material group	III	III	III
Material of contact	copper alloy	copper alloy	copper alloy
Contact plating	Au	Au	Au
Insulating material	PA	PA	PA
Material of housing	TPE	TPE	TPE

## Straight cable connectors, cable

Male connector moulded,screw

Contacts	Cable	Cable length	Designation	Order No.	
3	3x1.5PVC	1.5 m	7/8-M03-T-1.5-PVC	168 003 401 4001	
		5.0 m	7/8-M03-T-5.0-PVC	168 003 401 4002	
	3x1.5PUR	1.5 m	7/8-M03-T-1.5-PUR	168 003 401 4003	
		5.0 m	7/8-M03-T-5.0-PUR	168 003 401 4004	
4	4x1.5PVC	1.5 m	7/8-M04-T-1.5-PVC	168 004 401 4002	
		5.0 m	7/8-M04-T-5.0-PVC	168 004 401 4003	
	4x1.5PUR	1.5 m	7/8-M04-T-1.5-PUR	168 004 401 4004	
		5.0 m	7/8-M04-T-5.0-PUR	168 004 401 4005	
	5	5x1.5PVC	1.5 m	7/8-M05-T-1.5-PVC	168 005 401 4002
			5.0 m	7/8-M05-T-5.0-PVC	168 005 401 4003
5x1.5PUR	1.5 m	7/8-M05-T-1.5-PUR	168 005 401 4004		
	5.0 m	7/8-M05-T-5.0-PUR	168 005 401 4005		



7/8



2+PE



3+PE



4+PE

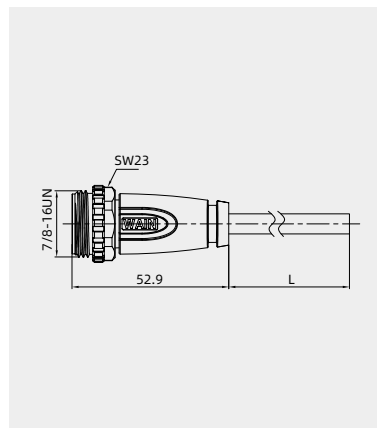

## 7/8 Circular Connector

300V 12/9A

## Technical characteristics

Number of contacts	3 (2+PE)	4 (3+PE)	5 (4+PE)
Rated current (40°C)	12A	9A	9A
Rated voltage	300V	300V	300V
Rated impulse voltage	4000V	4000V	4000V
Pollution degree	3	3	3
Overvoltage categorie	III	III	III
Contact resistance	≤ 3 mΩ	≤ 3 mΩ	≤ 3 mΩ
Connector locking system	screw7/8-16UN	screw7/8-16UN	screw7/8-16UN
Termination	screw	screw	screw
Wire gauge	max.1.5mm <sup>2</sup> (max.AWG16)	max.1.5mm <sup>2</sup> (max.AWG16)	max.1.5mm <sup>2</sup> (max.AWG16)
Degree of protection	IP67	IP67	IP67
Mechanical operation	> 100	> 100	> 100
Limiting temperature	-25°C ...+85°C	-25°C ...+85°C	-25°C ...+85°C
Material group	III	III	III
Material of contact	copper alloy	copper alloy	copper alloy
Contact plating	Au	Au	Au
Insulating material	PA	PA	PA
Material of housing	TPE	TPE	TPE

## Angled cable connectors,cable

Male connector moulded,screw

Recommended use



7/8



2+PE



3+PE



4+PE

Contacts	Cable	Cable length	Designation	Order No.
3	3x1.5PVC	1.5 m	7/8-M03-S-1.5-PVC	168 003 501 4001
		5.0 m	7/8-M03-S-5.0-PVC	168 003 501 4002
	3x1.5PUR	1.5 m	7/8-M03-S-1.5-PUR	168 003 501 4003
		5.0 m	7/8-M03-S-5.0-PUR	168 003 501 4004
4	4x1.5PVC	1.5 m	7/8-M04-S-1.5-PVC	168 004 501 4001
		5.0 m	7/8-M04-S-5.0-PVC	168 004 501 4002
	4x1.5PUR	1.5 m	7/8-M04-S-1.5-PUR	168 004 501 4003
		5.0 m	7/8-M04-S-5.0-PUR	168 004 501 4004
5	5x1.5PVC	1.5 m	7/8-M05-S-1.5-PVC	168 005 501 4001
		5.0 m	7/8-M05-S-5.0-PVC	168 005 501 4002
	5x1.5PUR	1.5 m	7/8-M05-S-1.5-PUR	168 005 501 4003
		5.0 m	7/8-M05-S-5.0-PUR	168 005 501 4004

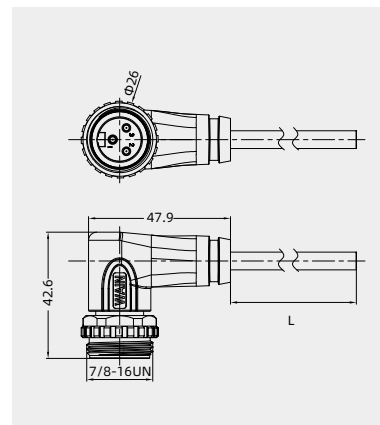

## 7/8 Circular Connector

300V 12/9A

## Technical characteristics

Number of contacts	3 (2+PE)	4 (3+PE)	5 (4+PE)
Rated current (40°C)	12A	9A	9A
Rated voltage	300V	300V	300V
Rated impulse voltage	4000V	4000V	4000V
Pollution degree	3	3	3
Overvoltage categorie	III	III	III
Contact resistance	≤ 3 mΩ	≤ 3 mΩ	≤ 3 mΩ
Connector locking system	screw7/8-16UN	screw7/8-16UN	screw7/8-16UN
Termination	screw	screw	screw
Wire gauge	max.1.5mm <sup>2</sup> (max.AWG16)	max.1.5mm <sup>2</sup> (max.AWG16)	max.1.5mm <sup>2</sup> (max.AWG16)
Degree of protection	IP67	IP67	IP67
Mechanical operation	> 100	> 100	> 100
Limiting temperature	-25°C ...+85°C	-25°C ...+85°C	-25°C ...+85°C
Material group	III	III	III
Material of contact	copper alloy	copper alloy	copper alloy
Contact plating	Au	Au	Au
Insulating material	PA	PA	PA
Material of housing	TPE	TPE	TPE

## Straight cable connectors, cable

Female connector moulded,screw

## Recommended use



7/8



2+PE



3+PE



4+PE

Contacts	Cable	Cable length	Designation	Order No.	
3	3x1.5PVC	1.5 m	7/8-F03-T-1.5-PVC	168 003 402 4001	
		5.0 m	7/8-F03-T-5.0-PVC	168 003 402 4002	
	3x1.5PUR	1.5 m	7/8-F03-T-1.5-PUR	168 003 402 4003	
		5.0 m	7/8-F03-T-5.0-PUR	168 003 402 4004	
4	4x1.5PVC	1.5 m	7/8-F04-T-1.5-PVC	168 004 402 4002	
		5.0 m	7/8-F04-T-5.0-PVC	168 004 402 4003	
	4x1.5PUR	1.5 m	7/8-F04-T-1.5-PUR	168 004 402 4004	
		5.0 m	7/8-F04-T-5.0-PUR	168 004 402 4005	
	5	5x1.5PVC	1.5 m	7/8-F05-T-1.5-PVC	168 005 402 4002
			5.0 m	7/8-F05-T-5.0-PVC	168 005 402 4003
5x1.5PUR		1.5 m	7/8-F05-T-1.5-PUR	168 005 402 4004	
		5.0 m	7/8-F05-T-5.0-PUR	168 005 402 4005	

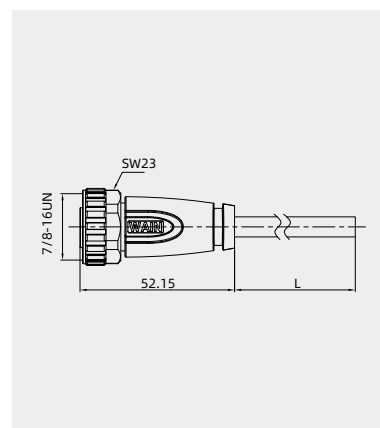

## 7/8 Circular Connector

300V 12/9A

## Technical characteristics

Number of contacts	3 (2+PE)	4 (3+PE)	5 (4+PE)
Rated current (40°C)	12A	9A	9A
Rated voltage	300V	300V	300V
Rated impulse voltage	4000V	4000V	4000V
Pollution degree	3	3	3
Overvoltage categorie	III	III	III
Contact resistance	≤ 3 mΩ	≤ 3 mΩ	≤ 3 mΩ
Connector locking system	screw7/8-16UN	screw7/8-16UN	screw7/8-16UN
Termination	screw	screw	screw
Wire gauge	max.1.5mm <sup>2</sup> (max.AWG16)	max.1.5mm <sup>2</sup> (max.AWG16)	max.1.5mm <sup>2</sup> (max.AWG16)
Degree of protection	IP67	IP67	IP67
Mechanical operation	> 100	> 100	> 100
Limiting temperature	-25°C ...+85°C	-25°C ...+85°C	-25°C ...+85°C
Material group	III	III	III
Material of contact	copper alloy	copper alloy	copper alloy
Contact plating	Au	Au	Au
Insulating material	PA	PA	PA
Material of housing	TPE	TPE	TPE

## Angled cable connectors,cable

Female connector moulded,screw

## Recommended use



7/8



2+PE



3+PE



4+PE

Contacts	Cable	Cable length	Designation	Order No.	
3	3x1.5PVC	1.5 m	7/8-F03-S-1.5-PVC	168 003 502 4001	
		5.0 m	7/8-F03-S-5.0-PVC	168 003 502 4002	
	3x1.5PUR	1.5 m	7/8-F03-S-1.5-PUR	168 003 502 4003	
		5.0 m	7/8-F03-S-5.0-PUR	168 003 502 4004	
4	4x1.5PVC	1.5 m	7/8-F04-S-1.5-PVC	168 004 502 4001	
		5.0 m	7/8-F04-S-5.0-PVC	168 004 502 4002	
	4x1.5PUR	1.5 m	7/8-F04-S-1.5-PUR	168 004 502 4003	
		5.0 m	7/8-F04-S-5.0-PUR	168 004 502 4004	
	5	5x1.5PVC	1.5 m	7/8-F05-S-1.5-PVC	168 005 502 4001
			5.0 m	7/8-F05-S-5.0-PVC	168 005 502 4002
5x1.5PUR		1.5 m	7/8-F05-S-1.5-PUR	168 005 502 4003	
		5.0 m	7/8-F05-S-5.0-PUR	168 005 502 4004	

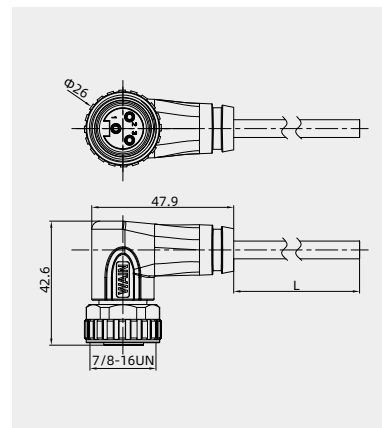

## 7/8 Circular Connector

300V 10/8A

## Technical characteristics

Number of contacts	3 (2+PE)	4 (3+PE)	5 (4+PE)
Rated current (40°C)	10A	8A	8A
Rated voltage	300V	300V	300V
Rated impulse voltage	2500V	2500V	2500V
Pollution degree	3	3	3
Overvoltage categorie	III	III	III
Contact resistance	≤ 3 mΩ	≤ 3 mΩ	≤ 3 mΩ
Connector locking system	screw7/8-16UN	screw7/8-16UN	screw7/8-16UN
Termination	single wires	single wires	single wires
Wire gauge	max.1.5mm <sup>2</sup> (max.AWG16)	max.1.5mm <sup>2</sup> (max.AWG16)	max.1.5mm <sup>2</sup> (max.AWG16)
Cable outlet	-	-	-
Degree of protection	IP67	IP67	IP67
Mechanical operation	> 100	> 100	> 100
Limiting temperature	-25°C ...+85°C	-25°C ...+85°C	-25°C ...+85°C
Material group	II	II	II
Material of contact	copper alloy	copper alloy	copper alloy
Contact plating	Au	Au	Au
Insulating material	TPU	TPU	TPU
Material of housing	brass nickel plated	brass nickel plated	brass nickel plated

## Socket

## Male panel mount connector

with single wires,  
0.82mm<sup>2</sup>, MAX.1.5mm<sup>2</sup>  
length 0.2m  
font fastened



7/8



## Male panel mount connector ,solder



7/8



Contacts	screw	Designation	Order No.
3 (2+PE)	PG11	7/8-M03-BK-PG11-W0.82	168 003 301 4001
	PG13.5	7/8-M03-BK-PG13.5-W0.82	168 003 301 4002
	M20×1.5	7/8-M03-BK-M20-W0.82	168 003 301 4003
4 (3+PE)	PG11	7/8-M04-BK-PG11-W0.82	168 004 301 4001
	PG13.5	7/8-M04-BK-PG13.5-W0.82	168 004 301 4002
	M20×1.5	7/8-M04-BK-M20-W0.82	168 004 301 4003
5 (4+PE)	PG11	7/8-M05-BK-PG11-W0.82	168 005 301 4001
	PG13.5	7/8-M05-BK-PG13.5-W0.82	168 005 301 4002
	M20×1.5	7/8-M05-BK-M20-W0.82	168 005 301 4003

Customized cable length upon request

Contacts	screw	Designation	Order No.
3 (2+PE)	PG11	7/8-M03-BK-PG11-C	168 003 313 1500
	PG13.5	7/8-M03-BK-PG13.5-C	168 003 313 1501
	M20×1.5	7/8-M03-BK-M20-C	168 003 313 1502
4 (3+PE)	PG11	7/8-M04-BK-PG11-C	168 004 313 1500
	PG13.5	7/8-M04-BK-PG13.5-C	168 004 313 1501
	M20×1.5	7/8-M04-BK-M20-C	168 004 301 4009
5 (4+PE)	PG11	7/8-M05-BK-PG11-C	168 005 313 1500
	PG13.5	7/8-M05-BK-PG13.5-C	168 005 313 1501
	M20×1.5	7/8-M05-BK-M20-C	168 005 313 0500

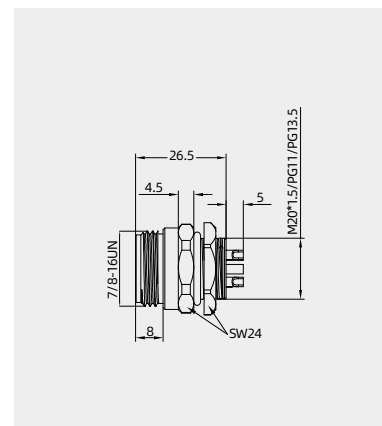
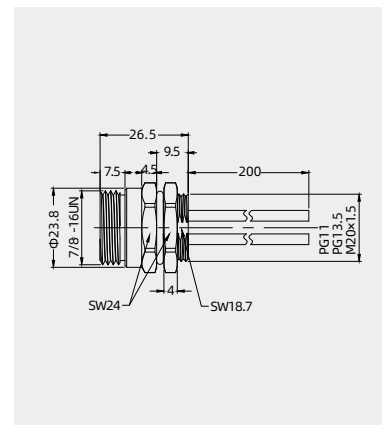

7/8

## 7/8 Circular Connector

300V 10/8A

## Technical characteristics

Number of contacts	3 (2+PE)	4 (3+PE)	5 (4+PE)
Rated current (40°C)	10A	8A	8A
Rated voltage	300V	300V	300V
Rated impulse voltage	2500V	2500V	2500V
Pollution degree	3	3	3
Overvoltage categorie	III	III	III
Contact resistance	≤ 3 mΩ	≤ 3 mΩ	≤ 3 mΩ
Connector locking system	screw 7/8-16UN	screw 7/8-16UN	screw 7/8-16UN
Termination	single wires	single wires	single wires
Wire gauge	max.1.5mm <sup>2</sup> (max.AWG16)	max.1.5mm <sup>2</sup> (max.AWG16)	max.1.5mm <sup>2</sup> (max.AWG16)
Cable outlet	-	-	-
Degree of protection	IP67	IP67	IP67
Mechanical operation	> 100	> 100	> 100
Limiting temperature	-25°C ...+85°C	-25°C ...+85°C	-25°C ...+85°C
Material group	II	II	II
Material of contact	copper alloy	copper alloy	copper alloy
Contact plating	Au	Au	Au
Insulating material	TPU	TPU	TPU
Material of housing	brass nickel plated	brass nickel plated	brass nickel plated

## Socket

## Female panel mount connector

with single wires,  
0.82mm<sup>2</sup>, MAX.1.5mm<sup>2</sup>  
length 0.2m  
font fastened



7/8



Contacts	screw	Designation	Order No.
3 (2+PE)	7/8-16UN	7/8-F03-BK-7/8-W0.82	168 003 302 4004
	PG11	7/8-F03-BK-PG11-W0.82	168 003 302 4001
	PG13.5	7/8-F03-BK-PG13.5-W0.82	168 003 302 4002
	M20×1.5	7/8-F03-BK-M20-W0.82	168 003 302 4003
4 (3+PE)	7/8-16UN	7/8-F04-BK-7/8-W0.82	168 004 302 4005
	PG11	7/8-F04-BK-PG11-W0.82	168 004 302 4001
	PG13.5	7/8-F04-BK-PG13.5-W0.82	168 004 302 4002
	M20×1.5	7/8-F04-BK-M20-W0.82	168 004 302 4003
5 (4+PE)	7/8-16UN	7/8-F05-BK-7/8-W0.82	168 005 302 4005
	PG11	7/8-F05-BK-PG11-W0.82	168 005 302 4001
	PG13.5	7/8-F05-BK-PG13.5-W0.82	168 005 302 4002
	M20×1.5	7/8-F05-BK-M20-W0.82	168 005 302 4003

Customized cable length upon request

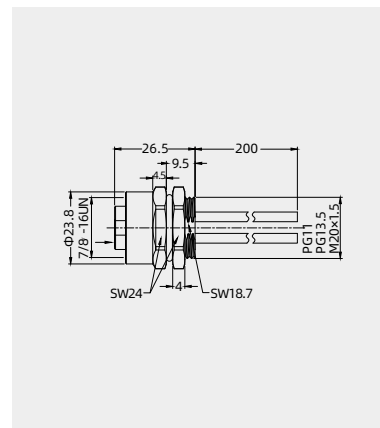

## Female panel mount connector , solder



7/8

7/8



Contacts	screw	Designation	Order No.
3 (2+PE)	PG11	7/8-F03-BK-PG11-C	168 003 323 1500
	PG13.5	7/8-F03-BK-PG13.5-C	168 003 323 1501
	M20×1.5	7/8-F03-BK-M20-C	168 003 323 1502
4 (3+PE)	PG11	7/8-F04-BK-PG11-C	168 004 323 1500
	PG13.5	7/8-F04-BK-PG13.5-C	168 004 323 1501
	M20×1.5	7/8-F04-BK-M20-C	168 004 323 1502
5 (4+PE)	PG11	7/8-F05-BK-PG11-C	168 005 323 1500
	PG13.5	7/8-F05-BK-PG13.5-C	168 005 323 1501
	M20×1.5	7/8-F05-BK-M20-C	168 005 323 1502

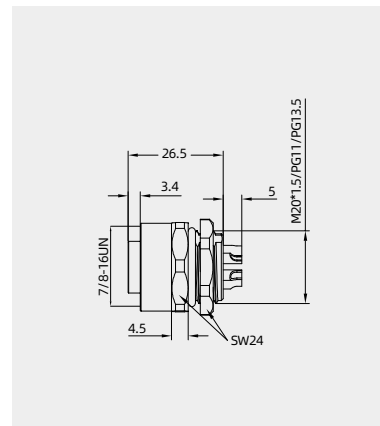



## 7/8 Circular Connector

300V 10/8A

## Technical characteristics

Number of contacts	3 (2+PE)	4 (3+PE)	5 (4+PE)
Rated current (40°C)	10A	8A	8A
Rated voltage	300V	300V	300V
Rated impulse voltage	2500V	2500V	2500V
Pollution degree	3	3	3
Overvoltage categorie	III	III	III
Contact resistance	≤ 3 mΩ	≤ 3 mΩ	≤ 3 mΩ
Connector locking system	screw7/8-16UN	screw7/8-16UN	screw7/8-16UN
Termination	single wires	single wires	single wires
Wire gauge	max.1.5mm <sup>2</sup> (max.AWG16)	max.1.5mm <sup>2</sup> (max.AWG16)	max.1.5mm <sup>2</sup> (max.AWG16)
Cable outlet	-	-	-
Degree of protection	IP67	IP67	IP67
Mechanical operation	> 100	> 100	> 100
Limiting temperature	-25°C ...+85°C	-25°C ...+85°C	-25°C ...+85°C
Material group	II	II	II
Material of contact	copper alloy	copper alloy	copper alloy
Contact plating	Au	Au	Au
Insulating material	TPU	TPU	TPU
Material of housing	brass nickel plated	brass nickel plated	brass nickel plated

## Socket

## Male panel mount connector

with single wires,  
0.82mm<sup>2</sup>, MAX.1.5mm<sup>2</sup>  
length 0.2m  
font fastened



7/8



Contacts	screw	Designation	Order No.
3 (2+PE)	7/8-16UN	7/8-M03-BKR-7/8-W0.82	168 003 301 4004
4 (3+PE)	7/8-16UN	7/8-M04-BKR-7/8-W0.82	168 004 301 4004
5 (4+PE)	7/8-16UN	7/8-M05-BKR-7/8-W0.82	168 005 301 4004

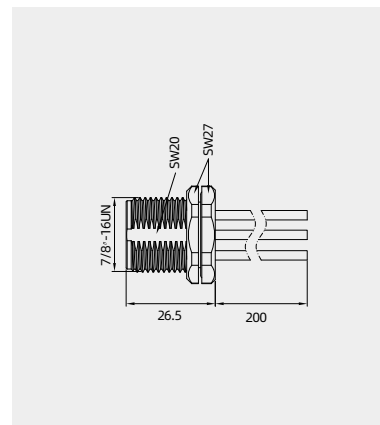

Customized cable length upon request

Male panel mount connector ,solder  
font fastened

7/8



Contacts	screw	Designation	Order No.
3 (2+PE)	7/8-16UN	7/8-M03-BKR-7/8-C	168 003 313 1503
4 (3+PE)	7/8-16UN	7/8-M04-BKR-7/8-C	168 004 313 1502
5 (4+PE)	7/8-16UN	7/8-M05-BKR-7/8-C	168 005 313 1502

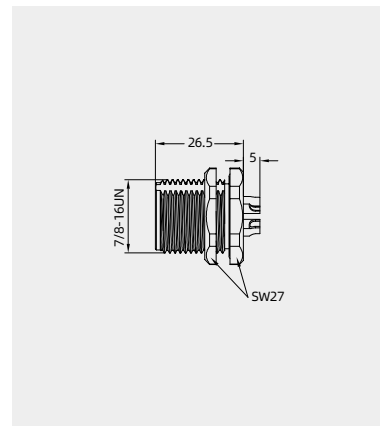

## 7/8 Circular Connector

300V 10/8A

## Technical characteristics

Number of contacts	3 (2+PE)	4 (3+PE)	5 (4+PE)
Rated current (40°C)	10A	8A	8A
Rated voltage	300V	300V	300V
Rated impulse voltage	2500V	2500V	2500V
Pollution degree	3	3	3
Overvoltage categorie	III	III	III
Contact resistance	≤ 3 mΩ	≤ 3 mΩ	≤ 3 mΩ
Connector locking system	screw7/8-16UN	screw7/8-16UN	screw7/8-16UN
Termination	single wires	single wires	single wires
Wire gauge	max.1.5mm <sup>2</sup> (max.AWG16)	max.1.5mm <sup>2</sup> (max.AWG16)	max.1.5mm <sup>2</sup> (max.AWG16)
Cable outlet	-	-	-
Degree of protection	IP67	IP67	IP67
Mechanical operation	> 100	> 100	> 100
Limiting temperature	-25°C ...+85°C	-25°C ...+85°C	-25°C ...+85°C
Material group	II	II	II
Material of contact	copper alloy	copper alloy	copper alloy
Contact plating	Au	Au	Au
Insulating material	TPU	TPU	TPU
Material of housing	brass nickel plated	brass nickel plated	brass nickel plated

## Socket

Female panel mount connector  
with single wires, 0.82mm<sup>2</sup>,  
MAX.1.5mm<sup>2</sup>, length 0.2m  
font fastened



7/8



Contacts	screw	Designation	Order No.
3 (2+PE)	M26	7/8-F03-BKR-M26-W0.82	168 003 302 4005
4 (3+PE)	M26	7/8-F04-BKR-M26-W0.82	168 004 302 4006
5 (4+PE)	M26	7/8-F05-BKR-M26-W0.82	168 005 302 4006

Customized cable length upon request

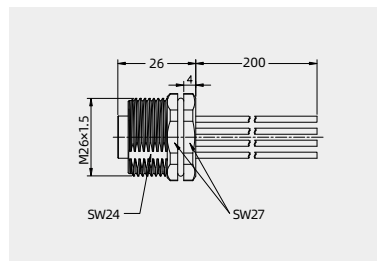

Female panel mount connector  
with single wires, 0.82mm<sup>2</sup>,  
MAX.1.5mm<sup>2</sup>, length 0.2m  
font fastened



7/8



Contacts	screw	Designation	Order No.
3 (2+PE)	7/8-16UN	7/8-F03-BKR-7/8-W0.82	168 003 302 4006
4 (3+PE)	7/8-16UN	7/8-F04-BKR-7/8-W0.82	168 003 302 4007
5 (4+PE)	7/8-16UN	7/8-F05-BKR-7/8-W0.82	168 003 302 4008

Customized cable length upon request

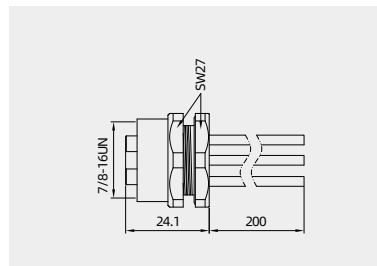

Female panel mount connector,  
solder



7/8



Contacts	screw	Designation	Order No.
3 (2+PE)	7/8-16UN	7/8-F03-BKR-7/8-C	168 003 323 1503
4 (3+PE)	7/8-16UN	7/8-F04-BKR-7/8-C	168 004 323 1503
5 (4+PE)	7/8-16UN	7/8-F05-BKR-7/8-C	168 005 323 1503

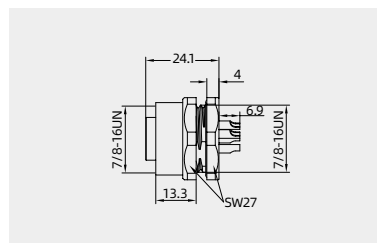

Female panel mount connector,  
solder



7/8



Contacts	screw	Designation	Order No.
3 (2+PE)	M26	7/8-F03-BKR-M26-C	168 003 323 1504
4 (3+PE)	M26	7/8-F04-BKR-M26-C	168 004 323 1504
5 (4+PE)	M26	7/8-F05-BKR-M26-C	168 005 323 1504

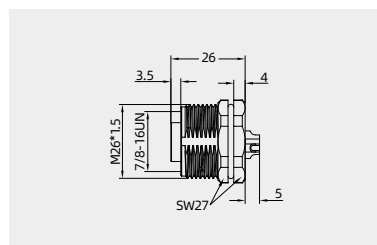

## 7/8 Circular Connector

300V 10/8A

## Technical characteristics

Number of contacts	3 (2+PE)	4 (3+PE)	5 (4+PE)
Rated current (40°C)	10A	8A	8A
Rated voltage	300V	300V	300V
Rated impulse voltage	2500V	2500V	2500V
Pollution degree	3	3	3
Overvoltage categorie	II	II	II
Contact resistance	≤ 3 mΩ	≤ 3 mΩ	≤ 3 mΩ
Connector locking system	screw 7/8-16UN	screw 7/8-16UN	screw 7/8-16UN
Termination	-	-	-
Wire gauge	-	-	-
Cable outlet	-	-	-
Degree of protection	IP67	IP67	IP67
Mechanical operation	> 100	> 100	> 100
Limiting temperature	-25°C ...+85°C	-25°C ...+85°C	-25°C ...+85°C
Material group	II	II	II
Material of contact	copper alloy	copper alloy	copper alloy
Contact plating	Au	Au	Au
Insulating material	TPU	TPU	TPU
Material of housing	brass nickel plated	brass nickel plated	brass nickel plated

## Socket

Male integrate with female  
direct tighten

7/8



2+PE 3+PE 4+PE



2+PE 3+PE 4+PE

Contacts	screw	Designation	Order No.
3 (2+PE)	7/8-16UN	7/8-M03-BK-F03-7/8	168 003 300 1001
4 (3+PE)	7/8-16UN	7/8-M04-BK-F04-7/8	168 003 300 1002
5 (4+PE)	7/8-16UN	7/8-M05-BK-F05-7/8	168 003 300 1003

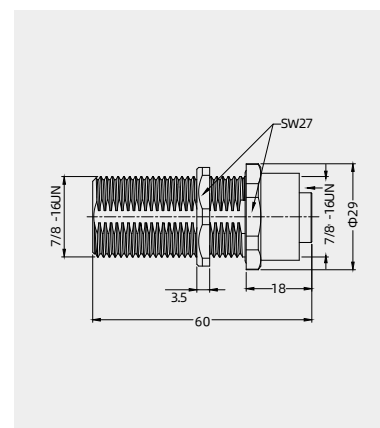

## 7/8 Circular Connector

- Contact arrangements

- Male insert (mating side)

3 (2+PE)

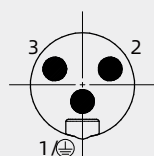

	X	Y	
1/⊕	0.00	-2.36	1 green/yellow
2	3.94	2.26	2 brown
3	-3.94	2.26	3 blue

- Female insert (mating side)

3 (2+PE)

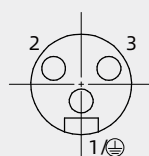

	X	Y	
1/⊕	0.00	-2.36	1 green/yellow
2	-3.94	2.26	2 brown
3	3.94	2.26	3 blue

4 (3+PE)

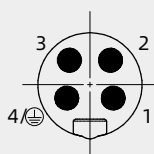

	X	Y	
1	3.30	-1.90	1 black
2	2.92	3.48	2 blue
3	-2.92	3.48	3 brown
4/⊕	-3.30	-1.90	4 white

4 (3+PE)

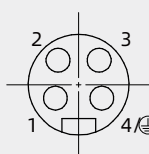

	X	Y	
1	-3.30	-1.90	1 black
2	-2.92	3.48	2 blue
3	2.92	3.48	3 brown
4/⊕	3.30	-1.90	4 white

5 (4+PE)

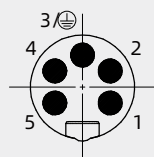

	X	Y	
1	3.94	-2.28	1 black
2	3.94	2.28	2 blue
3/⊕	0.00	4.54	3 green/yellow
4	-3.94	2.28	4 brown
5	-3.94	-2.28	5 white

5 (4+PE)

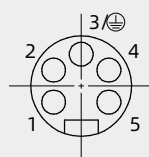

	X	Y	
1	-3.94	-2.28	1 black
2	-3.94	2.28	2 blue
3/⊕	0.00	4.54	3 green/yellow
4	3.94	2.28	4 brown
5	3.94	-2.28	5 white

- Panel cut out

7/8

- Front panel mounting, back panel tighten
- Through-hole mounting
- Screw mounting

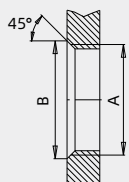
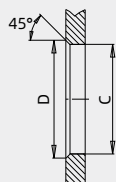
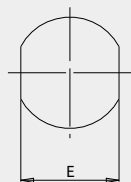

	A	B	C	D	E
PG11	PG11	20.2	18.7	20.2	17.0
PG13.5	PG13.5	22.2	20.5	22.2	18.8
M20×1.5	M20×1.5	21.6	20.1	21.6	17.8

Accessories

Protection cap IP67

Protection cover  
for male cable connector



Description	Designation	Order No.
Without cord	7/8-MCV	168 000 001 9003
With cord	7/8-MCV/1	168 000 001 9001

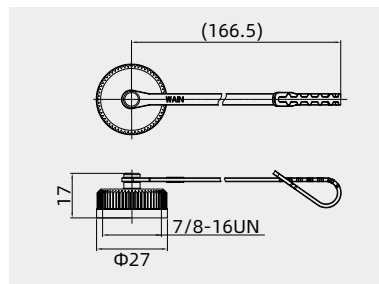

Protection cover  
for female cable connector



Description	Designation	Order No.
Without cord	7/8-FCV	168 000 002 9003
With cord	7/8-FCV/1	168 000 002 9001

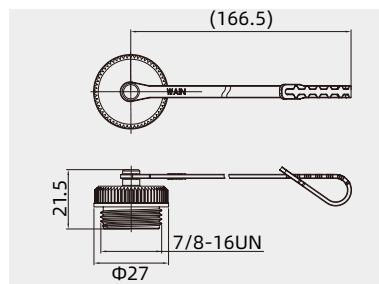

## M15 Circular connector



- [Cable Connector](#)
- Features a quick-connect structure for straightforward and convenient installation
- Full metal shell, effectively anti-electromagnetic interference
- Cold-pressed contacts, effectively anti-vibration and highly data transmission stabilizing
- Fixition of contacts into inserts by side press, easy assembly and maintainance without tools

## M15 Circular Connector

63V- 5A

## Technical characteristics

Specifications			
Specifications	DIN EN 60 664 DIN EN 61 984		
Approvals			
Electrical data	Mechanical data		
Number of contacts	12	Housing material	zinc alloy
ContactsΦ(mm)	Φ1	Housing surface	Nickel-plated
Connection range(mm°)	0.05-0.75	Insulating bodies	PBT
Terminal	Crimp terminal	Sealed compound	Fluorine rubber
Rated current(25°C)	5A	Temperature range	-25°C ...+130°C
Rated voltage	63V	Mechanical working life	>500
Rated impulse voltage	1.5KV	Degree of protection	IP67
Overvoltage categorie	III		
Pollution degree	3		
Flammability acc. to UL 94	UL94 V0		
Altitude	2000M		

Contact needs to be ordered separately

## Crimp terminal

order crimp contacts separately



Contacts	Designation	Order No.
12	M15Q-MC012-T-D6.5-SH	184 012 400 2503
	M15Q-MC012-T-D8.5-SH	184 012 400 2502
	M15Q-MC012-T-D10.5-SH	184 012 400 2500

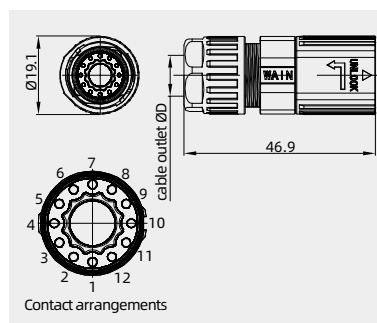

## Crimp contacts

Crimp contacts 5A

Wire gauge(mm <sup>2</sup> )	Male	Order No.
0.05-0.75	M15-MC5G-0.75	101 014 210 0650

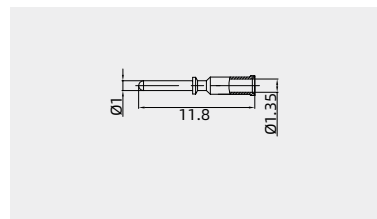

## Tools

Crimping tool



Wire gauge	Designation	Order No.
0.09-0.82mm <sup>2</sup>	TL03	198 001 001 0002

Notes: The tools of crimp terminal may influence the product quality and stability. Please select the tools recognized by our company

## M15 Circular Connector

63V- 5A

## Technical characteristics

Specifications			
Specifications	DIN EN 60 664 DIN EN 61 984		
Approvals			
Electrical data		Mechanical data	
Number of contacts	12	Housing material	zinc alloy
ContactsΦ(mm)	Φ1	Housing surface	Nickel-plated
Connection range(mm°)	0.05-0.75	Insulating bodies	PBT
Terminal	Crimp terminal	Sealed compound	Fluorine rubber
Rated current(25°C)	5A	Temperature range	-25°C ...+130°C
Rated voltage	63V	Mechanical working life	>500
Rated impulse voltage	1.5KV	Degree of protection	IP67
Overvoltage categorie	III		
Pollution degree	3		
Flammability acc. to UL 94	UL94 V0		
Altitude	2000M		

Contact needs to be ordered separately

## Crimp terminal

order crimp contacts separately



Contacts	Designation	Order No.
12	M15Q-FC012-T-D6.5-SH	184 012 420 2502
	M15Q-FC012-T-D8.5-SH	184 012 420 2500
	M15Q-FC012-T-D10.5-SH	184 012 420 2501

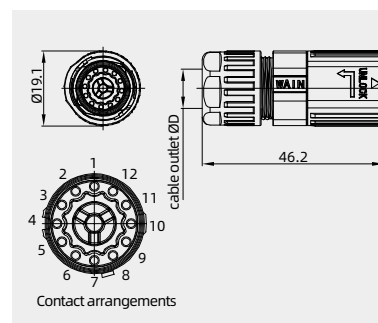

## Crimp contacts

Crimp contacts 5A



Wire gauge(mm <sup>2</sup> )	Female	Order No.
0.05-0.75	M15-FC5G-0.75	101 014 220 0650

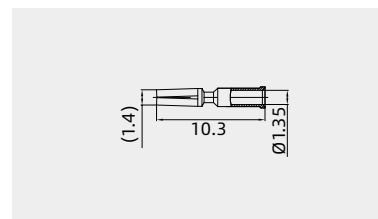

Tools

Crimping tool



Wire gauge	Designation	Order No.
0.09-0.82mm <sup>2</sup>	TL03	198 001 001 0002

Notes: The tools of crimp terminal may influence the product quality and stability. Please select the tools recognized by our company



## M15 Circular Connector

63V- 5A

## Technical characteristics

Specifications			
Specifications	DIN EN 60 664		
	DIN EN 61 984		
Approvals			
Electrical data		Mechanical data	
Number of contacts	12	Housing material	zinc alloy
ContactsΦ(mm)	Φ1	Housing surface	Nickel-plated
Connection range(mm°)	0.05-0.75	Insulating bodies	PBT
Terminal	Crimp terminal	Sealed compound	Fluorine rubber
Rated current(25°C)	5A	Temperature range	-25°C ...+130°C
Rated voltage	63V	Mechanical working life	>500
Rated impulse voltage	1.5KV	Degree of protection	IP67
Overvoltage categorie	III		
Pollution degree	3		
Flammability acc. to UL 94	UL94 V0		
Altitude	2000M		

Contact needs to be ordered separately

## Crimp terminal

order crimp contacts separately



Contacts	Designation	Order No.
	M15Q-MC012-BKR-M18	184 012310 1500

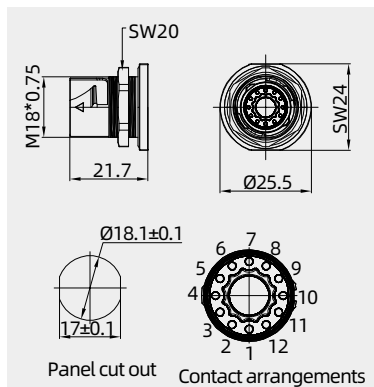

## Crimp contacts

Crimp contacts 5A



Wire gauge(mm <sup>2</sup> )	Male	Order No.
0.05-0.75	M15-MC5G-0.75	101 014 210 0650

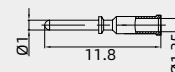

## Tools

Crimping tool



Wire gauge	Designation	Order No.
0.09-0.82mm <sup>2</sup>	TL03	198 001 001 0002

Notes: The tools of crimp terminal may influence the product quality and stability. Please select the tools recognized by our company

## M15 Circular Connector

63V- 5A

## Technical characteristics

Specifications			
Specifications	DIN EN 60 664 DIN EN 61 984		
Approvals			
Electrical data		Mechanical data	
Number of contacts	12	Housing material	zinc alloy
ContactsΦ(mm)	Φ1	Housing surface	Nickel-plated
Connection range(mm°)	0.05-0.75	Insulating bodies	PBT
Terminal	Crimp terminal	Sealed compound	Fluorine rubber
Rated current(25°C)	5A	Temperature range	-25°C ...+130°C
Rated voltage	63V	Mechanical working life	>500
Rated impulse voltage	1.5KV	Degree of protection	IP67
Overvoltage categorie	III		
Pollution degree	3		
Flammability acc. to UL 94	UL94 V0		
Altitude	2000M		

Contact needs to be ordered separately

## Crimp terminal

order crimp contacts separately



Contacts	Designation	Order No.
12	M15Q-FC012-BKR-M18	184 012 310 1500

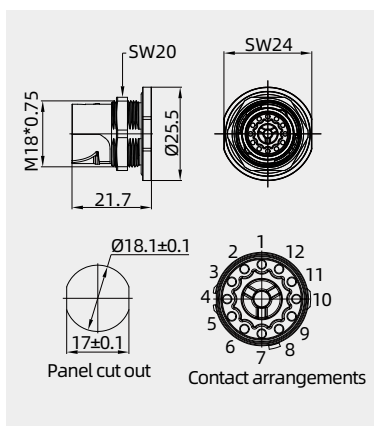

## Crimp contacts

Crimp contacts 5A



Wire gauge(mm <sup>2</sup> )	Female	Order No.
0.05-0.75	M15-FC5G-0.75	101 014 220 0650

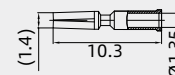

## Tools

Crimping tool



Wire gauge	Designation	Order No.
0.09-0.82mm <sup>2</sup>	TL03	198 001 001 0002

Notes: The tools of crimp terminal may influence the product quality and stability. Please select the tools recognized by our company

## M15 Circular Connector

63V- 5A

## Technical characteristics

Specifications			
Specifications	DIN EN 60 664		
	DIN EN 61 984		
Approvals			
Electrical data		Mechanical data	
Number of contacts	12	Housing material	zinc alloy
ContactsΦ(mm)	Φ1	Housing surface	Nickel-plated
Connection range(mm°)	0.05-0.75	Insulating bodies	PBT
Terminal	Crimp terminal	Sealed compound	Fluorine rubber
Rated current(25°C)	5A	Temperature range	-25°C ...+130°C
Rated voltage	63V	Mechanical working life	>500
Rated impulse voltage	1.5KV	Degree of protection	IP67
Overvoltage categorie	III		
Pollution degree	3		
Flammability acc. to UL 94	UL94 V0		
Altitude	2000M		

Contact needs to be ordered separately

## Crimp terminal

order crimp contacts separately



Contacts	Designation	Order No.
	M15Q-MC012-BK26-OD3.1	184 012 310 1501

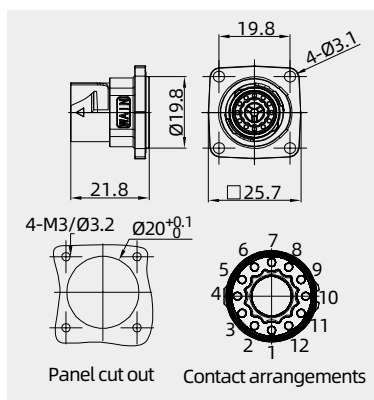

## Crimp contacts

Crimp contacts 5A

Wire gauge(mm <sup>2</sup> )	Male	Order No.
0.05-0.75	M15-MC5G-0.75	101 014 210 0650

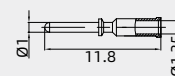

## Tools

Crimping tool



Wire gauge	Designation	Order No.
0.09-0.82mm <sup>2</sup>	TL03	198 001 001 0002

Notes: The tools of crimp terminal may influence the product quality and stability. Please select the tools recognized by our company

## M15 Circular Connector

63V- 5A

## Technical characteristics

Specifications			
Specifications	DIN EN 60 664 DIN EN 61 984		
Approvals			
Electrical data		Mechanical data	
Number of contacts	12	Housing material	zinc alloy
ContactsΦ(mm)	Φ1	Housing surface	Nickel-plated
Connection range(mm°)	0.05-0.75	Insulating bodies	PBT
Terminal	Crimp terminal	Sealed compound	Fluorine rubber
Rated current(25°C)	5A	Temperature range	-25°C ...+130°C
Rated voltage	63V	Mechanical working life	>500
Rated impulse voltage	1.5KV	Degree of protection	IP67
Overvoltage categorie	III		
Pollution degree	3		
Flammability acc. to UL 94	UL94 V0		
Altitude	2000M		

Contact needs to be ordered separately

## Crimp terminal

order crimp contacts separately



Contacts	Designation	Order No.
12	M15Q-FC012-BK26-OD3.1	184 012 310 1501

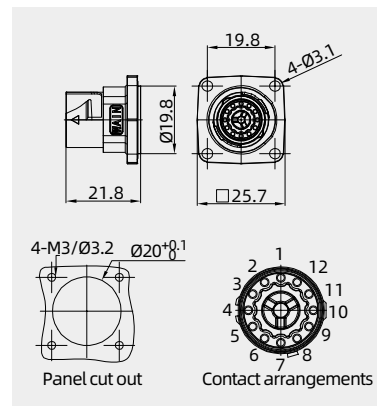

## Crimp contacts

Crimp contacts 5A



Wire gauge(mm <sup>2</sup> )	Female	Order No.
0.05-0.75	M15-FC5G-0.75	101 014 220 0650

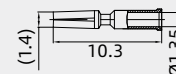

## Tools

Crimping tool



Wire gauge	Designation	Order No.
0.09-0.82mm <sup>2</sup>	TL03	198 001 001 0002

Notes: The tools of crimp terminal may influence the product quality and stability. Please select the tools recognized by our company

## Accessories

## Protection covers IP67

## Dust cover, Used in M15Q sockets



Description	Designation	Order No.
Without cord	M15-CV-F2	184 000 000 9500
With cord	M15-CV/1-F2	184 000 000 9502

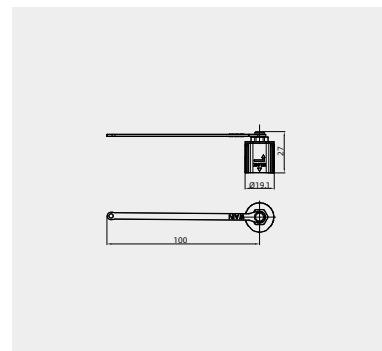

# M17 SERIES



## M17 Circular connector

630V- 20A

## Technical characteristics

Specifications			
Specifications	DIN EN 60 664 DIN EN 61 984		
Approvals			
Electrical data	Mechanical data		
Number of contacts	4(3+PE)	Housing material	copper alloy,zinc alloy
Rated current	20A	Housing surface	Nickel-plated
mm <sup>2</sup> / AWG	(0.35-2.5 mm <sup>2</sup> / AWG 22-14)	Contact resistance	≤ 5 mΩ
Rated voltage	630V	Insulating bodies	PBT
Rated impulse voltage	6kV	Contact material	copper alloy
Pollution degree	3	Contact surface	gold plated
Flammability acc. to UL 94	V0 (UL94)	Mechanical working life	>500
Overvoltage categorie	III	Degree of protection	IP67
		Temperature range	-40°C ...+130°C

## Male, Crimp terminal

order crimp contacts separately



Contacts	Cable outlet	Designation	Order No.
4(3+PE)	6-9mm	M17-MC04-CCT-D9.5-SH	165 004 710 2500
	9-12mm	M17-MC04-CCT-D12-SH	165 004 710 2501

## Female, Crimp terminal

order crimp contacts separately



Contacts	Cable outlet	Designation	Order No.
4(3+PE)	6-9mm	M17-FC04-CCT-D9.5-SH	165 004 720 2500
	9-12mm	M17-FC04-CCT-D12-SH	165 004 720 2501

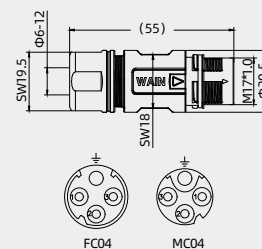

## Crimp contacts

## Crimp contacts 20A

20A



Wire gauge(mm <sup>2</sup> )	Male	Order No.
0.35-2.5	M17-MC20G-2.5	101 020 210 1002
Wire gauge(mm <sup>2</sup> )	Female	Order No.
0.35-2.5	M17-FC20G-2.5	101 020 220 1002

## Tools

Crimping tool



Wire gauge	Designation	Order No.
0.14-4 mm <sup>2</sup>	TL28-2	198 001 001 0039

Notes: The tools for crimp terminal may influence the product quality and stability. Please select the tools recognized by our company.

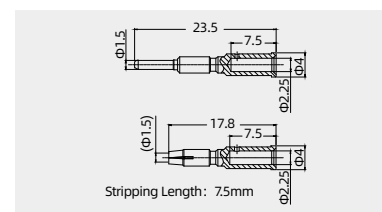

## M17 Circular connector

630V- 20A

## Technical characteristics

Specifications			
Specifications	DIN EN 60 664 DIN EN 61 984		
Approvals			
Electrical data	Mechanical data		
Number of contacts	4(3+PE)	Housing material	copper alloy,zinc alloy
Rated current	20A	Housing surface	Nickel-plated
mm <sup>2</sup> / AWG	(0.35-2.5 mm <sup>2</sup> / AWG 22-14)	Contact resistance	≤ 5 mΩ
Rated voltage	630V	Insulating bodies	PBT
Rated impulse voltage	6kV	Contact material	copper alloy
Pollution degree	3	Contact surface	gold plated
Flammability acc. to UL 94	V0 (UL94)	Mechanical working life	>500
Overvoltage categorie	III	Degree of protection	IP67
		Temperature range	-40°C ...+130°C

## Male, Crimp terminal

order crimp contacts separately



Contacts	Cable outlet	Designation	Order No.
4(3+PE)	6-9mm	M17-MC04-CCT/R-D9.5-SH	165 004 710 0500
	9-12mm	M17-MC04-CCT/R-D12-SH	165 004 710 2502

## Female, Crimp terminal

order crimp contacts separately



Contacts	Cable outlet	Designation	Order No.
4(3+PE)	6-9mm	M17-FC04-CCT/R-D9.5-SH	165 004 720 2502
	9-12mm	M17-FC04-CCT/R-D12-SH	165 004 720 2503

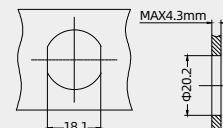
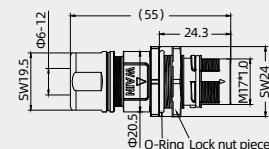

Panel Cut-out

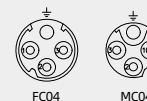

## Crimp contacts

## Crimp contacts 20A

Wire gauge(mm <sup>2</sup> )	Male	Order No.
0.35-2.5	M17-MC20G-2.5	101 020 210 1002

Wire gauge(mm <sup>2</sup> )	Female	Order No.
0.35-2.5	M17-FC20G-2.5	101 020 220 1002

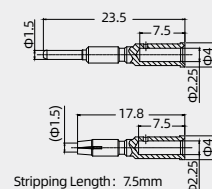

## Tools

Crimping tool



Wire gauge	Designation	Order No.
0.14-4 mm <sup>2</sup>	TL28-2	198 001 001 0039

Notes: The tools for crimp terminal may influence the product quality and stability. Please select the tools recognized by our company.



## M17 Circular connector

630V- 20A

## Technical characteristics

Specifications			
Specifications	DIN EN 60 664 DIN EN 61 984		
Approvals			
Electrical data	Mechanical data		
Number of contacts	4(3+PE)	Housing material	copper alloy,zinc alloy
Rated current	20A	Housing surface	Nickel-plated
mm <sup>2</sup> / AWG	(0.35-2.5 mm <sup>2</sup> / AWG 22-14)	Contact resistance	≤ 5 mΩ
Rated voltage	630V	Insulating bodies	PBT
Rated impulse voltage	6kV	Contact material	copper alloy
Pollution degree	3	Contact surface	gold plated
Flammability acc. to UL 94	V0 (UL94)	Mechanical working life	>500
Overvoltage categorie	III	Degree of protection	IP67
		Temperature range	-40°C ...+130°C

## Male, Crimp terminal

order crimp contacts separately



Contacts	Cable outlet	Designation	Order No.
4(3+PE)	6-9mm	M17-MC04-CCT/RA-D9.5-SH	165 004 710 2503
	9-12mm	M17-MC04-CCT/RA-D12-SH	165 004 710 2504

## Female, Crimp terminal

order crimp contacts separately



Contacts	Cable outlet	Designation	Order No.
4(3+PE)	6-9mm	M17-FC04-CCT/RA-D9.5-SH	165 004 720 2504
	9-12mm	M17-FC04-CCT/RA-D12-SH	165 004 720 2505

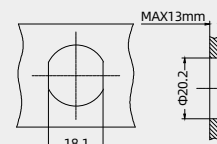
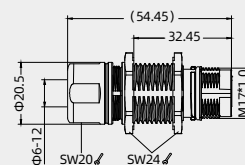

Panel Cut-out

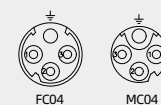

## Crimp contacts

## Crimp contacts 20A

20A



Wire gauge(mm <sup>2</sup> )	Male	Order No.
0.35-2.5	M17-MC20G-2.5	101 020 210 1002

Wire gauge(mm <sup>2</sup> )	Female	Order No.
0.35-2.5	M17-FC20G-2.5	101 020 220 1002

## Tools

Crimping tool



Wire gauge	Designation	Order No.
0.14-4 mm <sup>2</sup>	TL28-2	198 001 001 0039

Notes: The tools for crimp terminal may influence the product quality and stability. Please select the tools recognized by our company.

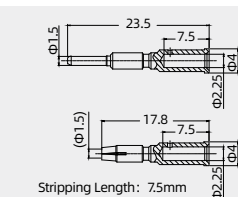

## M17 Circular connector

630V- 14A

## Technical characteristics

## Specifications

Specifications	DIN EN 60 664
	DIN EN 61 984

## Approvals

Electrical data		Mechanical data	
Number of contacts	7(6+PE)	Housing material	copper alloy,zinc alloy
Rated current	14A	Housing surface	Nickel-plated
mm <sup>2</sup> / AWG	(0.03-1.5mm <sup>2</sup> /AWG32-16)	Contact resistance	≤ 5 mΩ
Rated voltage	630 V	Insulating bodies	PBT
Rated impulse voltage	6kV	Contact material	copper alloy
Pollution degree	3	Contact surface	gold plated
Flammability acc. to UL 94	V0 (UL94)	Mechanical working life	>500
Overvoltage categorie	III	Degree of protection	IP67
		Temperature range	-40°C ...+130°C

## Crimp terminal

order crimp contacts separately



Contacts	Cable outlet	Designation	Order No.
7(6+PE)	6-9mm	M17-007-CCT-D9.5-SH	165 007 700 2503
	9-12mm	M17-007-CCT-D12-SH	165 007 700 2504
	6-9mm	M17-007R-CCT-D9.5-SH	165 007 700 2505
	9-12mm	M17-007R-CCT-D12-SH	165 007 700 2506
	6-9mm	M17-007/B-CCT-D9.5-SH	165 007 400 2010
	9-12mm	M17-007/B-CCT-D12-SH	165 007 400 2011
	6-9mm	M17-007R/B-CCT-D9.5-SH	165 007 700 2507
	9-12mm	M17-007R/B-CCT-D12-SH	165 007 700 2508

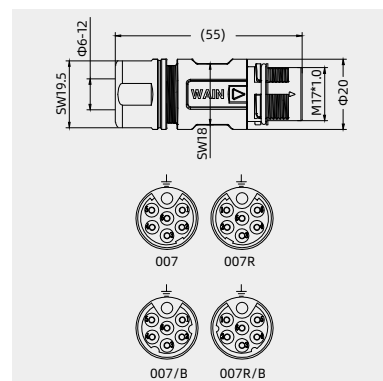
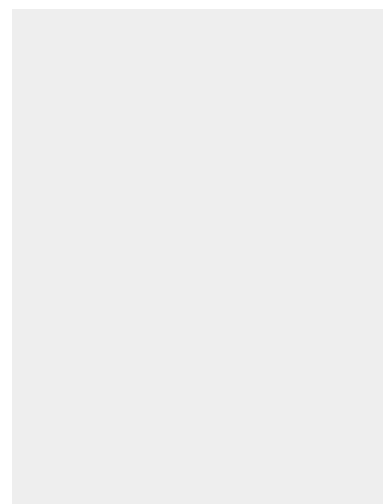

## Crimp contacts

## Crimp contacts

NO.	Wire gauge(mm <sup>2</sup> )	Male	Order No.
①	0.03-0.34	M23-MC9G-0.34	101 031 210 2501
②	0.14-1.0	M23-MC9G-1.0	101 031 210 0801
③	0.5-1.5	M23-MC9G-1.5	101 031 210 0901
NO.	Wire gauge(mm <sup>2</sup> )	Female	Order No.
①	0.03-0.34	M23-FC9G-0.34	101 031 220 2501
②	0.14-1.0	M23-FC9G-1.0	101 031 220 0801
③	0.5-1.5	M23-FC9G-1.5	101 031 220 0901

NO.	Φa	Φb	Stripping Length
①	1.7	0.9	4mm
②	2.1	1.45	4mm

NO.	Φa	Φb	c	Stripping Length
①	1.7	0.9	14	4mm
②	2.1	1.45	14	4mm
③	1.75	-	16.7	4.9mm

## Tools

## Crimping tool



Wire gauge	Designation	Order No.
0.14-4 mm <sup>2</sup>	TL28-2	198 001 001 0039

Notes: The tools for crimp terminal may influence the product quality and stability. Please select the tools recognized by our company.

Accessories

Stamped contacts

Stamped contacts



coil stock



Note: 10kpcs/volume

NO.	Wire gauge(mm <sup>2</sup> )	Male	Order No.
①	0.08-0.2	M23-MC9G-0.2P	101 031 210 0150
②	0.2-0.52	M23-MC9G-0.52P	101 031 210 0550
③	0.75-1.0	M23-MC9G-1.0P	101 031 210 0850
NO.	Wire gauge(mm <sup>2</sup> )	Female	Order No.
①	0.08-0.2	M23-FC9G-0.2P	101 031 220 0150
②	0.2-0.52	M23-FC9G-0.52P	101 031 220 0550
③	0.75-1.0	M23-FC9G-1.0P	101 031 220 0850

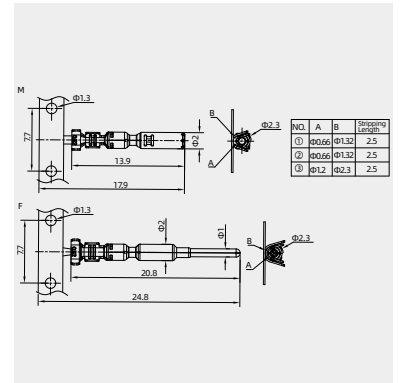

Tools

Terminal stamping machir



Wire gauge	Designation	Order No.
	M23-XC9G-MJ	903 020 000 0548

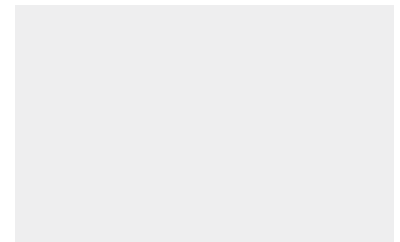

## M17 Circular connector

630V- 14A

## Technical characteristics

Specifications			
Specifications	DIN EN 60 664		
	DIN EN 61 984		
Approvals			
Electrical data		Mechanical data	
Number of contacts	7(6+PE)	Housing material	copper alloy,zinc alloy
Rated current	14A	Housing surface	Nickel-plated
mm <sup>2</sup> / AWG	(0.03-1.5mm <sup>2</sup> /AWG32-16)	Contact resistance	≤ 5 mΩ
Rated voltage	630 V	Insulating bodies	PBT
Rated impulse voltage	6kV	Contact material	copper alloy
Pollution degree	3	Contact surface	gold plated
Flammability acc. to UL 94	V0 (UL94)	Mechanical working life	>500
Overtoltage categorie	III	Degree of protection	IP67
		Temperature range	-40°C ...+130°C

## Crimp terminal

order crimp contacts separately



Contacts	Cable outlet	Designation	Order No.
7(6+PE)	6-9mm	M17-007-CCT/R-D9.5-SH	165 007 700 2500
	9-12mm	M17-007-CCT/R-D12-SH	165 007 700 2502
	6-9mm	M17-007R-CCT/R-D9.5-SH	165 007 700 2509
	9-12mm	M17-007R-CCT/R-D12-SH	165 007 700 2510
	6-9mm	M17-007/B-CCT/R-D9.5-SH	165 007 700 2511
	9-12mm	M17-007/B-CCT/R-D12-SH	165 007 700 2512
	6-9mm	M17-007R/B-CCT/R-D9.5-SH	165 007 700 2513
	9-12mm	M17-007R/B-CCT/R-D12-SH	165 007 700 2514

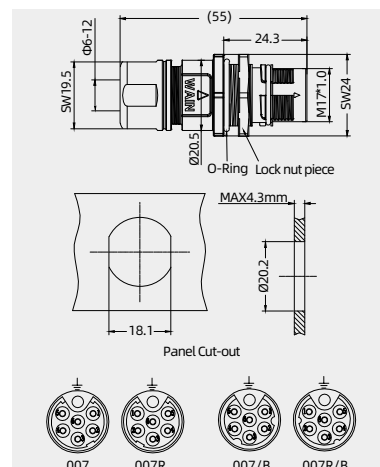
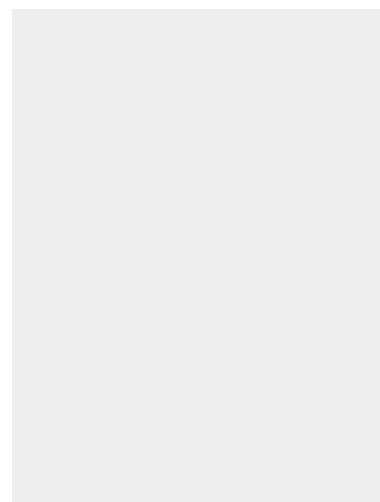

## Crimp contacts

Crimp contacts

NO.	Wire gauge(mm <sup>2</sup> )	Male	Order No.
①	0.03-0.34	M23-MC9G-0.34	101 031 210 2501
②	0.14-1.0	M23-MC9G-1.0	101 031 210 0801
③	0.5-1.5	M23-MC9G-1.5	101 031 210 0901
NO.	Wire gauge(mm <sup>2</sup> )	Female	Order No.
①	0.03-0.34	M23-FC9G-0.34	101 031 220 2501
②	0.14-1.0	M23-FC9G-1.0	101 031 220 0801
③	0.5-1.5	M23-FC9G-1.5	101 031 220 0901

NO.	Φa	Φb	Stripping Length
①	1.7	0.9	4mm
②	2.1	1.45	4mm

NO.	Φa	Φb	c	Stripping Length
①	1.7	0.9	14	4mm
②	2.1	1.45	14	4mm
③	1.75	-	16.7	4.9mm

## Tools

Crimping tool



Wire gauge	Designation	Order No.
0.14-4 mm <sup>2</sup>	TL28-2	198 001 001 0039

Notes: The tools for crimp terminal may influence the product quality and stability. Please select the tools recognized by our company.

Accessories

Stamped contacts

Stamped contacts



coil stock



Note: 10kpcs/volume

NO.	Wire gauge(mm <sup>2</sup> )	Male	Order No.
①	0.08-0.2	M23-MC9G-0.2P	101 031 210 0150
②	0.2-0.52	M23-MC9G-0.52P	101 031 210 0550
③	0.75-1.0	M23-MC9G-1.0P	101 031 210 0850
NO.	Wire gauge(mm <sup>2</sup> )	Female	Order No.
①	0.08-0.2	M23-FC9G-0.2P	101 031 220 0150
②	0.2-0.52	M23-FC9G-0.52P	101 031 220 0550
③	0.75-1.0	M23-FC9G-1.0P	101 031 220 0850

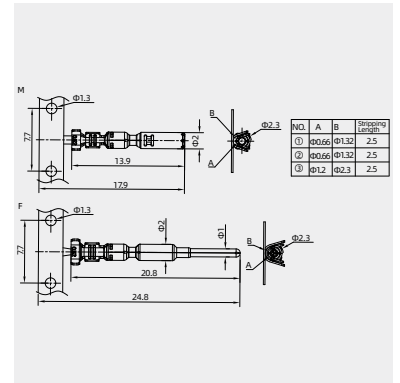

Tools

Terminal stamping machir



Wire gauge	Designation	Order No.
	M23-XC9G-MJ	903 020 000 0548

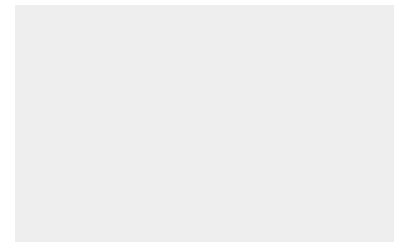

## M17 Circular connector

630V- 14A

## Technical characteristics

Specifications			
Specifications	DIN EN 60 664		
	DIN EN 61 984		
Approvals			
Electrical data		Mechanical data	
Number of contacts	7(6+PE)	Housing material	copper alloy,zinc alloy
Rated current	14A	Housing surface	Nickel-plated
mm <sup>2</sup> / AWG	(0.03-1.5mm <sup>2</sup> /AWG32-16)	Contact resistance	≤ 5 mΩ
Rated voltage	630 V	Insulating bodies	PBT
Rated impulse voltage	6kV	Contact material	copper alloy
Pollution degree	3	Contact surface	gold plated
Flammability acc. to UL 94	V0 (UL94)	Mechanical working life	>500
Overvoltage categorie	III	Degree of protection	IP67
		Temperature range	-40°C ...+130°C

## Crimp terminal

order crimp contacts separately



Contacts	Cable outlet	Designation	Order No.
7(6+PE)	6-9mm	M17-007-CCT/RA-D9.5-SH	165 007 700 2515
	9-12mm	M17-007-CCT/RA-D12-SH	165 007 700 2516
	6-9mm	M17-007R-CCT/RA-D9.5-SH	165 007 700 2517
	9-12mm	M17-007R-CCT/RA-D12-SH	165 007 700 2518
	6-9mm	M17-007/B-CCT/RA-D9.5-SH	165 007 700 2519
	9-12mm	M17-007/B-CCT/RA-D12-SH	165 007 700 2520
	6-9mm	M17-007R/B-CCT/RA-D9.5-SH	165 007 700 2521
	9-12mm	M17-007R/B-CCT/RA-D12-SH	165 007 700 2522

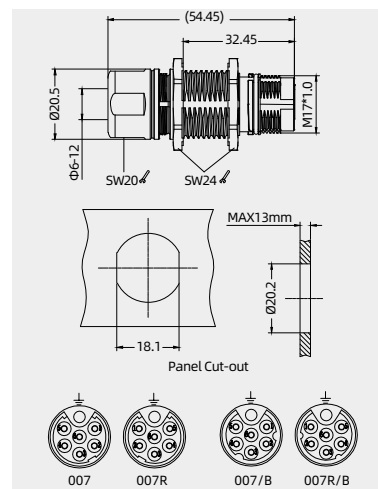

## Crimp contacts

## Crimp contacts

NO.	Wire gauge(mm <sup>2</sup> )	Male	Order No.
①	0.03-0.34	M23-MC9G-0.34	101 031 210 2501
②	0.14-1.0	M23-MC9G-1.0	101 031 210 0801
③	0.5-1.5	M23-MC9G-1.5	101 031 210 0901
NO.	Wire gauge(mm <sup>2</sup> )	Female	Order No.
①	0.03-0.34	M23-FC9G-0.34	101 031 220 2501
②	0.14-1.0	M23-FC9G-1.0	101 031 220 0801
③	0.5-1.5	M23-FC9G-1.5	101 031 220 0901

NO.	Φa	Φb	Stripping Length
①	1.7	0.9	4mm
②	2.1	1.45	4mm

NO.	Φa	Φb	c	Stripping Length
①	1.7	0.9	14	4mm
②	2.1	1.45	14	4mm
③	1.75	-	16.7	4.9mm

## Tools

## Crimping tool



Wire gauge	Designation	Order No.
0.14-4 mm <sup>2</sup>	TL28-2	198 001 001 0039

Notes: The tools for crimp terminal may influence the product quality and stability. Please select the tools recognized by our company.

Accessories

Stamped contacts

Stamped contacts



coil stock



Note: 10kpcs/volume

NO.	Wire gauge(mm <sup>2</sup> )	Male	Order No.
①	0.08-0.2	M23-MC9G-0.2P	101 031 210 0150
②	0.2-0.52	M23-MC9G-0.52P	101 031 210 0550
③	0.75-1.0	M23-MC9G-1.0P	101 031 210 0850
NO.	Wire gauge(mm <sup>2</sup> )	Female	Order No.
①	0.08-0.2	M23-FC9G-0.2P	101 031 220 0150
②	0.2-0.52	M23-FC9G-0.52P	101 031 220 0550
③	0.75-1.0	M23-FC9G-1.0P	101 031 220 0850

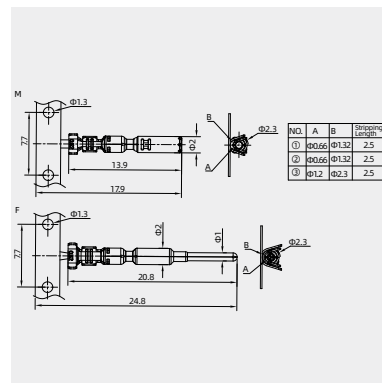

Tools

Terminal stamping machir



Wire gauge	Designation	Order No.
	M23-XC9G-MJ	903 020 000 0548

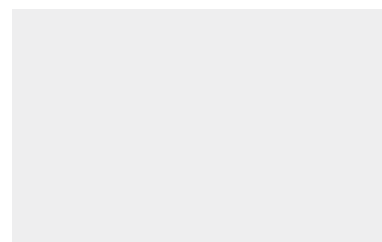

## M17 Circular connector

630/63V - 14/0.6A

## Technical characteristics

Specifications			
Specifications	DIN EN 60 664 DIN EN 61 984		
Approvals			
Electrical data		Mechanical data	
Number of contacts	5	3+PE	Housing material
Rated current	3.6	14A	Housing surface
mm <sup>2</sup> / AWG	0.14-0.5/26-20	0.03-1.5/32-16	Contact resistance
Rated voltage	63V	630V	Insulating bodies
Rated impulse voltage	1.5kV	6kV	Contact material
Pollution degree	3	3	Contact surface
Flammability acc. to UL 94	V0 (UL94)	V0 (UL94)	Mechanical working life
Overvoltage categorie	III	III	Degree of protection
			Temperature range

## Male, Crimp terminal

order crimp contacts separately



Contacts	Cable outlet	Designation	Order No.
9(5+4(3+PE))	6-9mm	M17-MC04/5-CCT-D9.5-SH	165 009 710 2500
	9-12mm	M17-MC04/5-CCT-D12-SH	165 009 710 2501

## Female, Crimp terminal

order crimp contacts separately



Contacts	Cable outlet	Designation	Order No.
9(5+4(3+PE))	6-9mm	M17-FC04/5-CCT-D9.5-SH	165 009 720 2500
	9-12mm	M17-FC04/5-CCT-D12-SH	165 009 720 2501

## Crimp contacts

## Crimp contacts 3.6A

3.6A(signal)



NO.	Wire gauge(mm <sup>2</sup> )	Male	Order No.
①	0.14-0.5	M17-MC3.6G-0.5	101 039 210 0401

NO.	Wire gauge(mm <sup>2</sup> )	Female	Order No.
①	0.14-0.5	M17-FC3.6G-0.5	101 039 220 0401

## Crimp contacts

power



NO.	Wire gauge(mm <sup>2</sup> )	Male	Order No.
①	0.03-0.34	M23-MC9G-0.34	101 031 210 2501
②	0.14-1.0	M23-MC9G-1.0	101 031 210 0801
③	0.5-1.5	M23-MC9G-1.5	101 031 210 0901

NO.	Wire gauge(mm <sup>2</sup> )	Female	Order No.
①	0.03-0.34	M23-FC9G-0.34	101 031 220 2501
②	0.14-1.0	M23-FC9G-1.0	101 031 220 0801
③	0.5-1.5	M23-FC9G-1.5	101 031 220 0901

## Tools

Crimping tool



Wire gauge	Designation	Order No.
0.09-0.82 mm <sup>2</sup>	TL03	198 001 001 0002

## Tools

Crimping tool



Wire gauge	Designation	Order No.
0.14-4 mm <sup>2</sup>	TL28-2	198 001 001 0039

Notes: The tools for crimp terminal may influence the product quality and stability. Please select the tools recognized by our company.

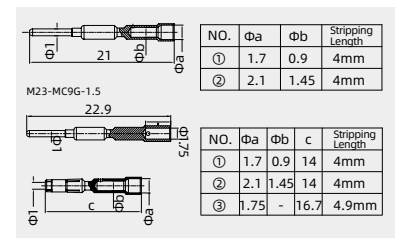
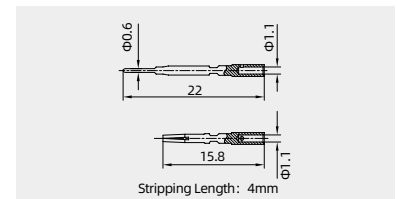
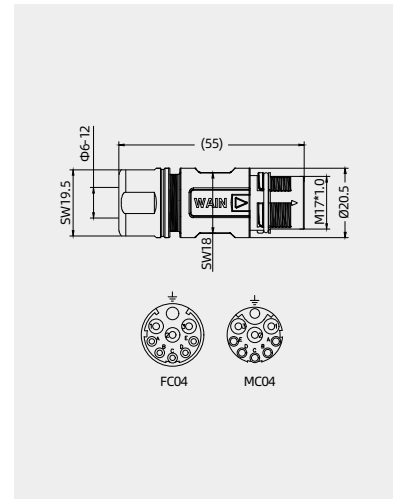
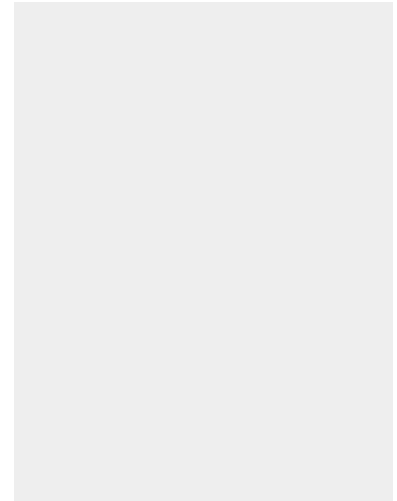



# Accessories

## Stamped contacts

### Stamped contacts



coil stock



Note: 10kpcs/volume

NO.	Wire gauge(mm <sup>2</sup> )	Male	Order No.
①	0.08-0.2	M23-MC9G-0.2P	101 031 210 0150
②	0.2-0.52	M23-MC9G-0.52P	101 031 210 0550
③	0.75-1.0	M23-MC9G-1.0P	101 031 210 0850

NO.	Wire gauge(mm <sup>2</sup> )	Female	Order No.
①	0.08-0.2	M23-FC9G-0.2P	101 031 220 0150
②	0.2-0.52	M23-FC9G-0.52P	101 031 220 0550
③	0.75-1.0	M23-FC9G-1.0P	101 031 220 0850

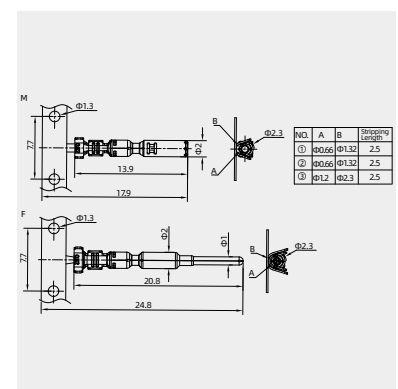

### Tools

Terminal stamping machir



Wire gauge	Designation	Order No.
	M23-XC9G-MJ	903 020 000 0548

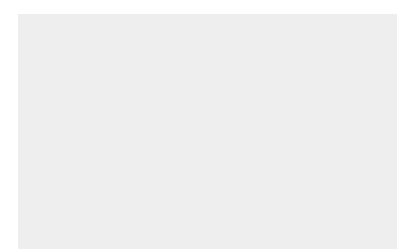

## M17 Circular connector

630/63V - 14/0.6A

## Technical characteristics

Specifications			
Specifications	DIN EN 60 664		
	DIN EN 61 984		
Approvals			
Electrical data		Mechanical data	
Number of contacts	5	3+PE	Housing material
Rated current	3.6	14A	Housing surface
mm <sup>2</sup> / AWG	0.14-0.5/26-20	0.03-1.5/32-16	Contact resistance
Rated voltage	63V	630V	Insulating bodies
Rated impulse voltage	1.5kV	6kV	Contact material
Pollution degree	3	3	Contact surface
Flammability acc. to UL 94	V0 (UL94)	V0 (UL94)	Mechanical working life
Overvoltage categorie	III	III	Degree of protection
			Temperature range

## Male, Crimp terminal

order crimp contacts separately



Contacts	Cable outlet	Designation	Order No.
9(5+4(3+PE))	6-9mm	M17-MC04/5-CCT/R-D9.5-SH	165 009 710 2502
	9-12mm	M17-MC04/5-CCT/R-D12-SH	165 009 710 2503

## Female, Crimp terminal

order crimp contacts separately



Contacts	Cable outlet	Designation	Order No.
9(5+4(3+PE))	6-9mm	M17-FC04/5-CCT/R-D9.5-SH	165 009 720 2502
	9-12mm	M17-FC04/5-CCT/R-D12-SH	165 009 720 2503

## Crimp contacts

## Crimp contacts 3.6A

3.6A(signal)



NO.	Wire gauge(mm <sup>2</sup> )	Male	Order No.
①	0.14-0.5	M17-MC3.6G-0.5	101 039 210 0401

NO.	Wire gauge(mm <sup>2</sup> )	Female	Order No.
①	0.14-0.5	M17-FC3.6G-0.5	101 039 220 0401

## Crimp contacts

power



NO.	Wire gauge(mm <sup>2</sup> )	Male	Order No.
①	0.03-0.34	M23-MC9G-0.34	101 031 210 2501
②	0.14-1.0	M23-MC9G-1.0	101 031 210 0801
③	0.5-1.5	M23-MC9G-1.5	101 031 210 0901

NO.	Wire gauge(mm <sup>2</sup> )	Female	Order No.
①	0.03-0.34	M23-FC9G-0.34	101 031 220 2501
②	0.14-1.0	M23-FC9G-1.0	101 031 220 0801
③	0.5-1.5	M23-FC9G-1.5	101 031 220 0901

## Tools

Crimping tool



Wire gauge	Designation	Order No.
0.09-0.82 mm <sup>2</sup>	TL03	198 001 001 0002

## Tools

Crimping tool



Wire gauge	Designation	Order No.
0.14-4 mm <sup>2</sup>	TL28-2	198 001 001 0039

Notes: The tools for crimp terminal may influence the product quality and stability. Please select the tools recognized by our company.

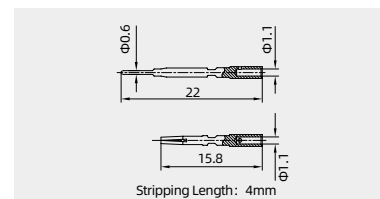
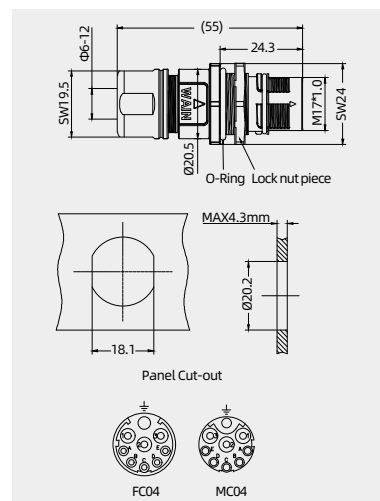
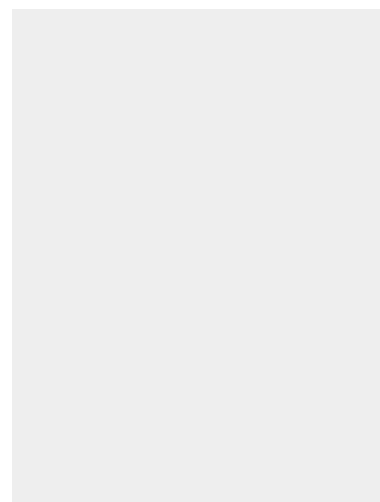

NO.	Øa	Øb	Stripping Length
①	1.7	0.9	4mm
②	2.1	1.45	4mm

NO.	Øa	Øb	c	Stripping Length
①	1.7	0.9	14	4mm
②	2.1	1.45	14	4mm
③	1.75	-	16.7	4.9mm

Accessories

Stamped contacts

Stamped contacts



coil stock



Note: 10kpcs/volume

NO.	Wire gauge(mm <sup>2</sup> )	Male	Order No.
①	0.08-0.2	M23-MC9G-0.2P	101 031 210 0150
②	0.2-0.52	M23-MC9G-0.52P	101 031 210 0550
③	0.75-1.0	M23-MC9G-1.0P	101 031 210 0850
NO.	Wire gauge(mm <sup>2</sup> )	Female	Order No.
①	0.08-0.2	M23-FC9G-0.2P	101 031 220 0150
②	0.2-0.52	M23-FC9G-0.52P	101 031 220 0550
③	0.75-1.0	M23-FC9G-1.0P	101 031 220 0850

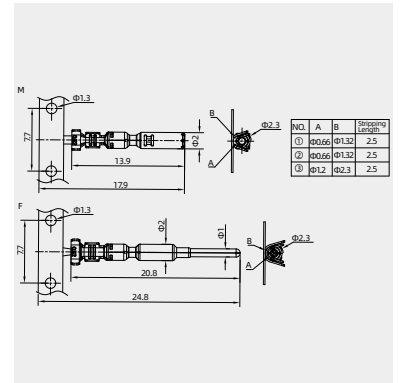

Tools

Terminal stamping machir



Wire gauge	Designation	Order No.
	M23-XC9G-MJ	903 020 000 0548

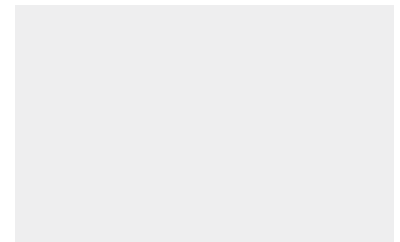

## M17 Circular connector

630/63V - 14/0.6A

## Technical characteristics

Specifications			
Specifications	DIN EN 60 664 DIN EN 61 984		
Approvals			
Electrical data		Mechanical data	
Number of contacts	5	3+PE	Housing material
Rated current	3.6	14A	Housing surface
mm <sup>2</sup> / AWG	0.14-0.5/26-20	0.03-1.5/32-16	Contact resistance
Rated voltage	63V	630V	Insulating bodies
Rated impulse voltage	1.5kV	6kV	Contact material
Pollution degree	3	3	Contact surface
Flammability acc. to UL 94	V0 (UL94)	V0 (UL94)	Mechanical working life
Overvoltage categorie	III	III	Degree of protection
			Temperature range

## Male, Crimp terminal

order crimp contacts separately



Contacts	Cable outlet	Designation	Order No.
9(5+4(3+PE))	6-9mm	M17-MC04/5-CCT/RA-D9.5-SH	165 009 710 2504
	9-12mm	M17-MC04/5-CCT/RA-D12-SH	165 009 710 2505

## Female, Crimp terminal

order crimp contacts separately



Contacts	Cable outlet	Designation	Order No.
9(5+4(3+PE))	6-9mm	M17-FC04/5-CCT/RA-D9.5-SH	165 009 720 2504
	9-12mm	M17-FC04/5-CCT/RA-D12-SH	165 009 720 2505

## Crimp contacts

## Crimp contacts 3.6A

3.6A



NO.	Wire gauge(mm <sup>2</sup> )	Male	Order No.
①	0.14-0.5	M17-MC3.6G-0.5	101 039 210 0401

NO.	Wire gauge(mm <sup>2</sup> )	Female	Order No.
①	0.14-0.5	M17-FC3.6G-0.5	101 039 220 0401

## Crimp contacts

power



NO.	Wire gauge(mm <sup>2</sup> )	Male	Order No.
①	0.03-0.34	M23-MC9G-0.34	101 031 210 2501
②	0.14-1.0	M23-MC9G-1.0	101 031 210 0801
③	0.5-1.5	M23-MC9G-1.5	101 031 210 0901

NO.	Wire gauge(mm <sup>2</sup> )	Female	Order No.
①	0.03-0.34	M23-FC9G-0.34	101 031 220 2501
②	0.14-1.0	M23-FC9G-1.0	101 031 220 0801
③	0.5-1.5	M23-FC9G-1.5	101 031 220 0901

## Tools

Crimping tool



Wire gauge	Designation	Order No.
0.09-0.82 mm <sup>2</sup>	TL03	198 001 001 0002

## Tools

Crimping tool



Wire gauge	Designation	Order No.
0.14-4 mm <sup>2</sup>	TL28-2	198 001 001 0039

Notes: The tools for crimp terminal may influence the product quality and stability. Please select the tools recognized by our company.

21S-01.9 WAIN ELECTRICAL

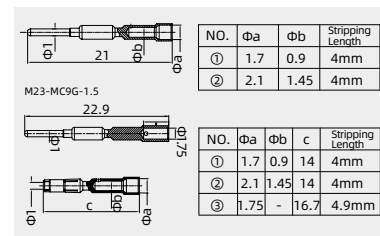
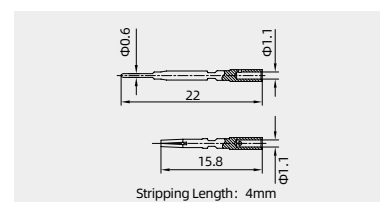
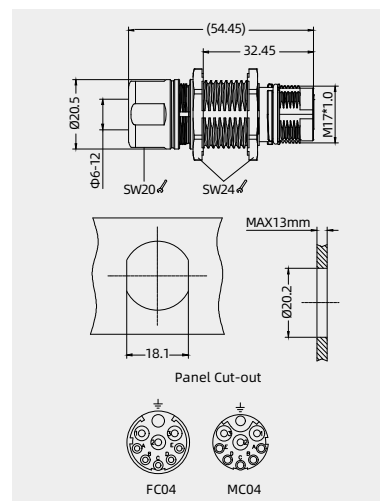
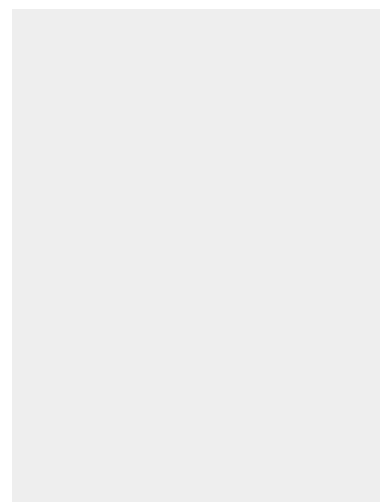

Accessories

Stamped contacts

Stamped contacts



coil stock



Note: 10kpcs/volume

NO.	Wire gauge(mm <sup>2</sup> )	Male	Order No.
①	0.08-0.2	M23-MC9G-0.2P	101 031 210 0150
②	0.2-0.52	M23-MC9G-0.52P	101 031 210 0550
③	0.75-1.0	M23-MC9G-1.0P	101 031 210 0850

NO.	Wire gauge(mm <sup>2</sup> )	Female	Order No.
①	0.08-0.2	M23-FC9G-0.2P	101 031 220 0150
②	0.2-0.52	M23-FC9G-0.52P	101 031 220 0550
③	0.75-1.0	M23-FC9G-1.0P	101 031 220 0850

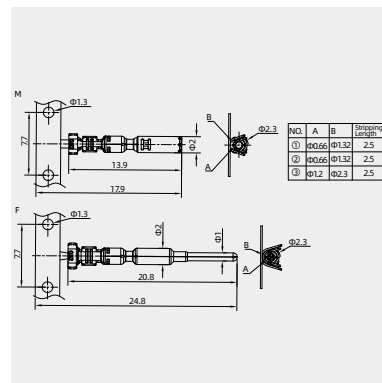

Tools

Terminal stamping machir



Wire gauge	Designation	Order No.
	M23-XC9G-MJ	903 020 000 0548

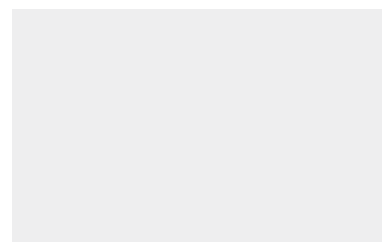

## M17 Circular connector

48V- 7.5A

## Technical characteristics

Specifications			
Specifications	DIN EN 60 664 DIN EN 61 984		
Approvals			
Electrical data	Mechanical data		
Number of contacts	10	Housing material	copper alloy,zinc alloy
Rated current	7.5A	Housing surface	Nickel-plated
mm <sup>2</sup> / AWG	(0.09-0.82mm <sup>2</sup> / AWG 28-18)	Contact resistance	≤ 10 mΩ
Rated voltage	48 V	Insulating bodies	PBT
Rated impulse voltage	1.5kV	Contact material	copper alloy
Pollution degree	3	Contact surface	gold plated
Flammability acc. to UL 94	V0 (UL94)	Mechanical working life	>500
Overvoltage categorie	III	Degree of protection	IP67
		Temperature range	-40°C ...+130°C

## Crimp terminal

order crimp contacts separately

Contacts	Cable outlet	Designation	Order No.
10	6-9.5mm	M17-MC010-CCT-D9.5-SH	165 010 710 2500
	9-12mm	M17-MC010-CCT-D12-SH	165 010 710 2501

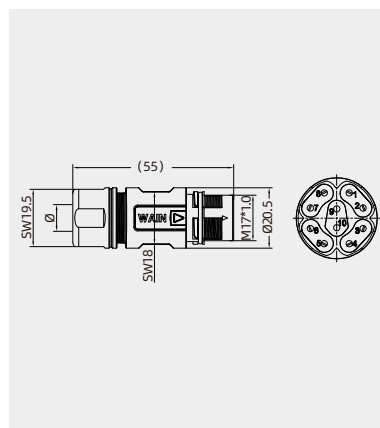
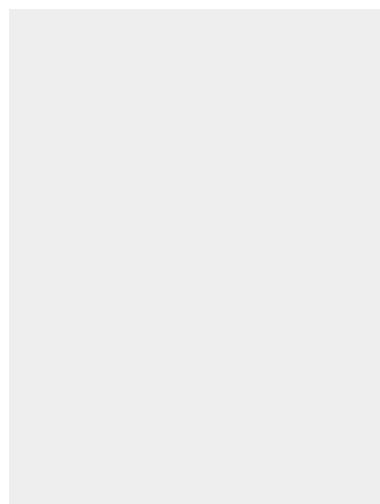

## Accessories

## Crimp contacts 5A

gold plated

Wire gauge(mm <sup>2</sup> )	Male	Order No.
0.09-0.25	CSGM-0.25	101 014 210 0101
0.13-0.33	CSGM-0.33	101 014 210 0201
0.33-0.52	CSGM-0.52	101 014 210 0501
0.33-0.82	CSGM-0.82	101 014 210 0701

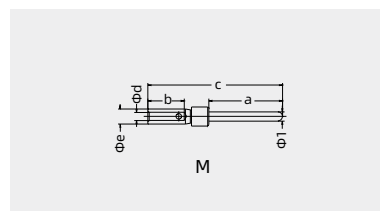

## Tools

Crimping tool

Wire gauge	Designation	Order No.
0.09-0.82mm <sup>2</sup>	TL03	198 001 001 0002



Notes: The tools for crimp terminal may influence the product quality and stability. Please select the tools recognized by our company.

## M17 Circular connector

48V- 7.5A

## Technical characteristics

Specifications			
Specifications	DIN EN 60 664 DIN EN 61 984		
Approvals			
Electrical data	Mechanical data		
Number of contacts	10	Housing material	copper alloy,zinc alloy
Rated current	7.5A	Housing surface	Nickel-plated
mm <sup>2</sup> / AWG	(0.09-0.82mm <sup>2</sup> /AWG28-18)	Contact resistance	≤ 10 mΩ
Rated voltage	48 V	Insulating bodies	PBT
Rated impulse voltage	1.5kV	Contact material	copper alloy
Pollution degree	3	Contact surface	gold plated
Flammability acc. to UL 94	V0 (UL94)	Mechanical working life	>500
Overtoltage categorie	III	Degree of protection	IP67
		Temperature range	-40°C ...+130°C

## Crimp terminal

order crimp contacts separately

Contacts	Cable outlet	Designation	Order No.
10	6-9.5mm	M17-MC010-CCT/R-D9.5-SH	165 010 710 2504
	9-12mm	M17-MC010-CCT/R-D12-SH	165 010 710 2505

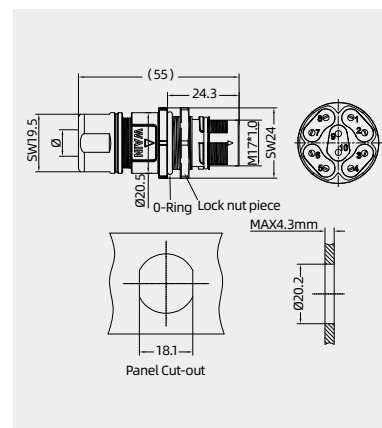
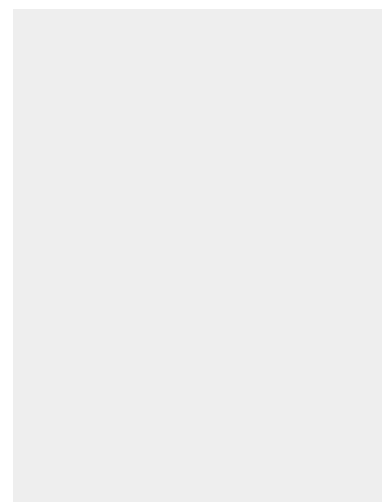

## Accessories

## Crimp contacts 5A

gold plated



Wire gauge(mm <sup>2</sup> )	Male	Order No.
0.09-0.25	CSGM-0.25	101 014 210 0101
0.13-0.33	CSGM-0.33	101 014 210 0201
0.33-0.52	CSGM-0.52	101 014 210 0501
0.33-0.82	CSGM-0.82	101 014 210 0701

## Tools

Crimping tool



Wire gauge	Designation	Order No.
0.09-0.82mm <sup>2</sup>	TL03	198 001 001 0002

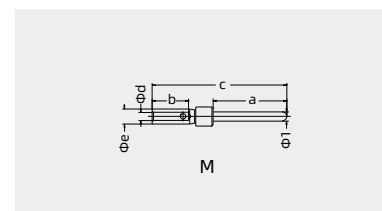

Notes: The tools for crimp terminal may influence the product quality and stability. Please select the tools recognized by our company.

## M17 Circular connector

48V- 7.5A

## Technical characteristics

Specifications			
Specifications	DIN EN 60 664 DIN EN 61 984		
Approvals			
Electrical data	Mechanical data		
Number of contacts	10	Housing material	copper alloy,zinc alloy
Rated current	7.5A	Housing surface	Nickel-plated
mm <sup>2</sup> / AWG	(0.09-0.82mm <sup>2</sup> / AWG 28-18)	Contact resistance	≤ 10 mΩ
Rated voltage	48 V	Insulating bodies	PBT
Rated impulse voltage	1.5kV	Contact material	copper alloy
Pollution degree	3	Contact surface	gold plated
Flammability acc. to UL 94	V0 (UL94)	Mechanical working life	>500
Overvoltage categorie	III	Degree of protection	IP67
		Temperature range	-40°C ...+130°C

## Crimp terminal

order crimp contacts separately

Contacts	Cable outlet	Designation	Order No.
10	6-9.5mm	M17-MC010-CCT/RA-D9.5-SH	165 010 710 2506
	9-12mm	M17-MC010-CCT/RA-D12-SH	165 010 710 2507

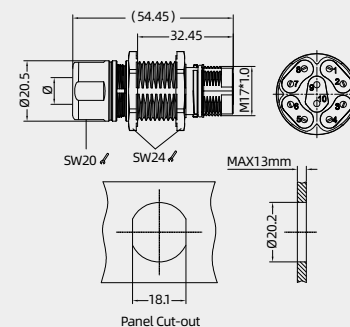

## Accessories

## Crimp contacts 5A

gold plated



Wire gauge(mm <sup>2</sup> )	Male	Order No.
0.09-0.25	CSGM-0.25	101 014 210 0101
0.13-0.33	CSGM-0.33	101 014 210 0201
0.33-0.52	CSGM-0.52	101 014 210 0501
0.33-0.82	CSGM-0.82	101 014 210 0701

## Tools

Crimping tool



Wire gauge	Designation	Order No.
0.09-0.82mm <sup>2</sup>	TL03	198 001 001 0002



Notes: The tools for crimp terminal may influence the product quality and stability. Please select the tools recognized by our company.



## M17 Circular connector

32V- 7A

## Technical characteristics

Specifications			
Specifications	DIN EN 60 664		
	DIN EN 61 984		
Approvals			
Electrical data		Mechanical data	
Number of contacts	12	Housing material	copper alloy,zinc alloy
Rated current	7A	Housing surface	Nickel-plated
mm <sup>2</sup> / AWG	(0.03-1.0mm <sup>2</sup> /AWG32-18)	Contact resistance	≤ 5 mΩ
Rated voltage	32 V	Insulating bodies	PBT
Rated impulse voltage	1.5kV	Contact material	copper alloy
Pollution degree	3	Contact surface	gold plated
Flammability acc. to UL 94	V0 (UL94)	Mechanical working life	>500
Overtoltage categorie	III	Degree of protection	IP67
		Temperature range	-40°C ...+130°C

## Crimp terminal

order crimp contacts separately



Contacts	Cable outlet	Designation	Order No.
12	6-9.5mm	M17-012-CCT-D9.5-SH	165 012 700 2501
	9-12mm	M17-012-CCT-D12-SH	165 012 700 2503

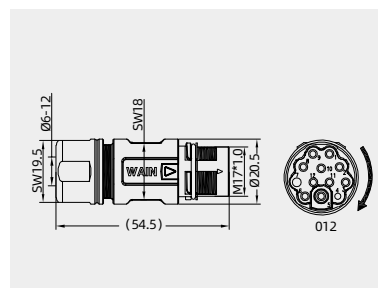

## Crimp contacts

Crimp contacts



NO.	Wire gauge(mm <sup>2</sup> )	Male	Order No.
①	0.03-0.34	M23-MC9G-0.34	101 031 210 2501
②	0.14-1.0	M23-MC9G-1.0	101 031 210 0801
NO.	Wire gauge(mm <sup>2</sup> )	Female	Order No.
①	0.03-0.34	M23-FC9G-0.34	101 031 220 2501
②	0.14-1.0	M23-FC9G-1.0	101 031 220 0801

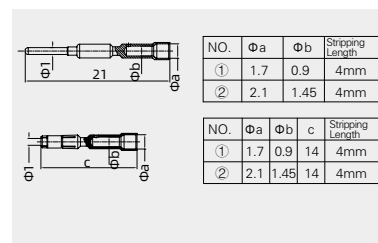

Tools

Crimping tool



Wire gauge	Designation	Order No.
0.14-4 mm <sup>2</sup>	TL28-2	198 001 001 0039

Notes: The tools for crimp terminal may influence the product quality and stability. Please select the tools recognized by our company.

Accessories

Stamped contacts

Stamped contacts



NO.	Wire gauge(mm <sup>2</sup> )	Male	Order No.
①	0.08-0.2	M23-MC9G-0.2P	101 031 210 0150
②	0.2-0.52	M23-MC9G-0.52P	101 031 210 0550
③	0.75-1.0	M23-MC9G-1.0P	101 031 210 0850
NO.	Wire gauge(mm <sup>2</sup> )	Female	Order No.
①	0.08-0.2	M23-FC9G-0.2P	101 031 220 0150
②	0.2-0.52	M23-FC9G-0.52P	101 031 220 0550
③	0.75-1.0	M23-FC9G-1.0P	101 031 220 0850

coil stock



Note: 10kpcs/volume

Tools

Terminal stamping machir



Wire gauge	Designation	Order No.
	M23-XC9G-MJ	903 020 000 0548

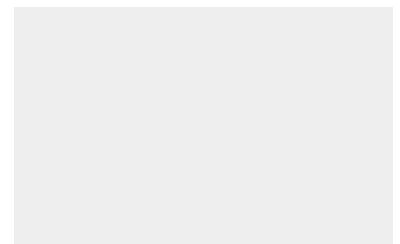
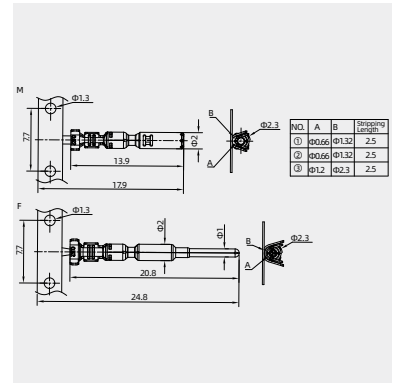

## M17 Circular connector

32V- 7A

## Technical characteristics

Specifications			
Specifications	DIN EN 60 664 DIN EN 61 984		
Approvals			
Electrical data	Mechanical data		
Number of contacts	12	Housing material	copper alloy,zinc alloy
Rated current	7A	Housing surface	Nickel-plated
mm <sup>2</sup> / AWG	(0.03-1.0mm <sup>2</sup> /AWG32-18)	Contact resistance	≤ 5 mΩ
Rated voltage	32 V	Insulating bodies	PBT
Rated impulse voltage	1.5kV	Contact material	copper alloy
Pollution degree	3	Contact surface	gold plated
Flammability acc. to UL 94	V0 (UL94)	Mechanical working life	>500
Overvoltage categorie	III	Degree of protection	IP67
		Temperature range	-40°C ...+130°C

## Crimp terminal

order crimp contacts separately



Contacts	Cable outlet	Designation	Order No.
12	6-9.5mm	M17-012-CCT/R-D9.5-SH	165 012 700 2500
	9-12mm	M17-012-CCT/R-D12-SH	165 012 400 2500

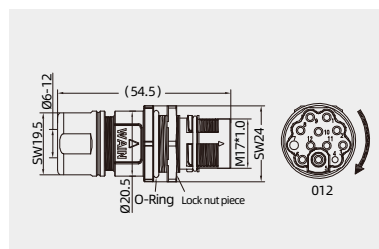
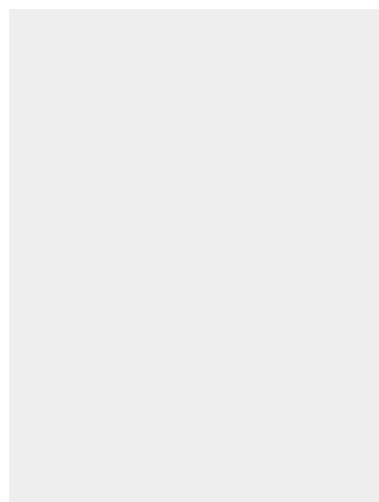

## Crimp contacts

Crimp contacts



NO.	Wire gauge(mm <sup>2</sup> )	Male	Order No.
①	0.03-0.34	M23-MC9G-0.34	101 031 210 2501
②	0.14-1.0	M23-MC9G-1.0	101 031 210 0801
NO.	Wire gauge(mm <sup>2</sup> )	Female	Order No.
①	0.03-0.34	M23-FC9G-0.34	101 031 220 2501
②	0.14-1.0	M23-FC9G-1.0	101 031 220 0801

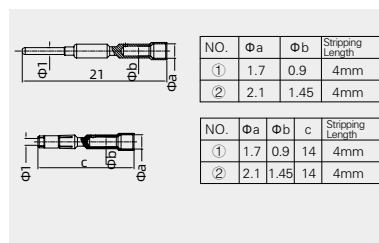

## Tools

Crimping tool



Wire gauge	Designation	Order No.
0.14-4 mm <sup>2</sup>	TL28-2	198 001 001 0039

Notes: The tools for crimp terminal may influence the product quality and stability. Please select the tools recognized by our company.

Accessories

Stamped contacts

Stamped contacts



NO.	Wire gauge(mm <sup>2</sup> )	Male	Order No.
①	0.08-0.2	M23-MC9G-0.2P	101 031 210 0150
②	0.2-0.52	M23-MC9G-0.52P	101 031 210 0550
③	0.75-1.0	M23-MC9G-1.0P	101 031 210 0850
NO.	Wire gauge(mm <sup>2</sup> )	Female	Order No.
①	0.08-0.2	M23-FC9G-0.2P	101 031 220 0150
②	0.2-0.52	M23-FC9G-0.52P	101 031 220 0550
③	0.75-1.0	M23-FC9G-1.0P	101 031 220 0850

coil stock



Note: 10kpcs/volume

Tools

Terminal stamping machir



Wire gauge	Designation	Order No.
	M23-XC9G-MJ	903 020 000 0548

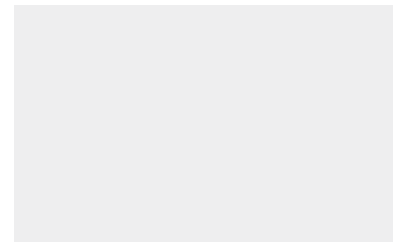
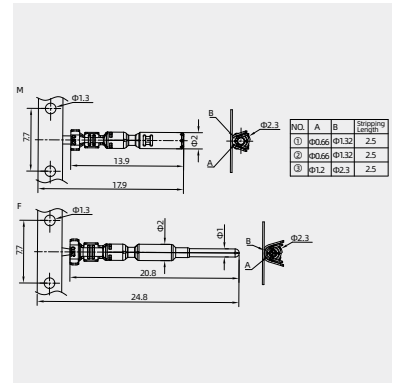

## M17 Circular connector

32V- 7A

## Technical characteristics

Specifications			
Specifications	DIN EN 60 664		
	DIN EN 61 984		
Approvals			
Electrical data		Mechanical data	
Number of contacts	12	Housing material	copper alloy,zinc alloy
Rated current	7A	Housing surface	Nickel-plated
mm <sup>2</sup> / AWG	(0.03-1.0mm <sup>2</sup> /AWG32-18)	Contact resistance	≤ 5 mΩ
Rated voltage	32 V	Insulating bodies	PBT
Rated impulse voltage	1.5kV	Contact material	copper alloy
Pollution degree	3	Contact surface	gold plated
Flammability acc. to UL 94	V0 (UL94)	Mechanical working life	>500
Overtoltage categorie	III	Degree of protection	IP67
		Temperature range	-40°C ...+130°C

## Crimp terminal

order crimp contacts separately



Contacts	Cable outlet	Designation	Order No.
12	6-9.5mm	M17-012-CCT/RA-D9.5-SH	165 012 400 2501
	9-12mm	M17-012-CCT/RA-D12-SH	165 012 400 2502

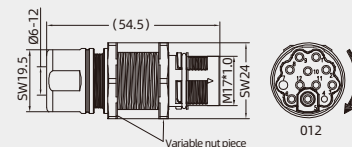

## Crimp contacts

Crimp contacts



NO.	Wire gauge(mm <sup>2</sup> )	Male	Order No.
①	0.03-0.34	M23-MC9G-0.34	101 031 210 2501
②	0.14-1.0	M23-MC9G-1.0	101 031 210 0801
NO.	Wire gauge(mm <sup>2</sup> )	Female	Order No.
①	0.03-0.34	M23-FC9G-0.34	101 031 220 2501
②	0.14-1.0	M23-FC9G-1.0	101 031 220 0801

NO.	Φa	Φb	Stripping Length
①	1.7	0.9	4mm
②	2.1	1.45	4mm

NO.	Φa	Φb	c	Stripping Length
①	1.7	0.9	14	4mm
②	2.1	1.45	14	4mm

Tools

Crimping tool



Wire gauge	Designation	Order No.
0.14-4 mm <sup>2</sup>	TL28-2	198 001 001 0039

Notes: The tools for crimp terminal may influence the product quality and stability. Please select the tools recognized by our company.

Accessories

Stamped contacts

Stamped contacts



coil stock



Note: 10kpcs/volume

Tools

Terminal stamping  
machir



NO.	Wire gauge(mm <sup>2</sup> )	Male	Order No.
①	0.08-0.2	M23-MC9G-0.2P	101 031 210 0150
②	0.2-0.52	M23-MC9G-0.52P	101 031 210 0550
③	0.75-1.0	M23-MC9G-1.0P	101 031 210 0850
NO.	Wire gauge(mm <sup>2</sup> )	Female	Order No.
①	0.08-0.2	M23-FC9G-0.2P	101 031 220 0150
②	0.2-0.52	M23-FC9G-0.52P	101 031 220 0550
③	0.75-1.0	M23-FC9G-1.0P	101 031 220 0850

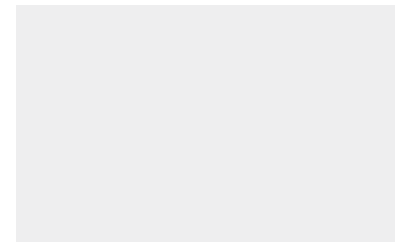
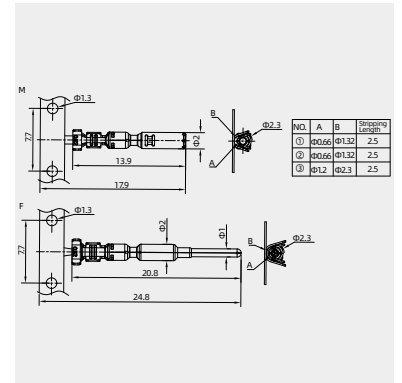

Wire gauge	Designation	Order No.
	M23-XC9G-MJ	903 020 000 0548

## M17 Circular connector

63V- 3.6A

## Technical characteristics

Specifications	
Specifications	DIN EN 60 664 DIN EN 61 984
Approvals	
Electrical data	
Number of contacts	17
Rated current	3.6A
mm <sup>2</sup> / AWG	(0.14-0.5 mm <sup>2</sup> / AWG 26-20)
Rated voltage	63 V
Rated impulse voltage	1.5kV
Pollution degree	3
Flammability acc. to UL 94 V0 (UL94)	
Overvoltage categorie	III
Mechanical data	
Housing material	copper alloy,zinc alloy
Housing surface	Nickel-plated
Contact resistance	≤ 5 mΩ
Insulating bodies	PBT
Contact material	copper alloy
Contact surface	gold plated
Mechanical working life	>500
Degree of protection	IP67
Temperature range	-40°C ...+130°C

## Male, Crimp terminal

order crimp contacts separately

Contacts	Cable outlet	Designation	Order No.
17	6-9.5mm	M17-MC017-CCT-D9.5-SH	165 017 710 2502
	9-12mm	M17-MC017-CCT-D12-SH	165 017 710 2503



## Female, Crimp terminal

order crimp contacts separately

Contacts	Cable outlet	Designation	Order No.
17	6-9.5mm	M17-FC017-CCT-D9.5-SH	165 017 420 2502
	9-12mm	M17-FC017-CCT-D12-SH	165 017 420 2503

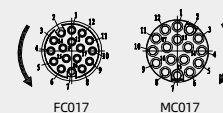
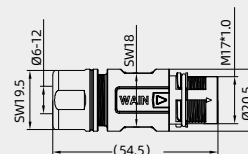

## Crimp contacts

## Crimp contacts 3.6A

3.6A



NO.	Wire gauge(mm <sup>2</sup> )	Male	Order No.
①	0.14-0.5	M17-MC3.6G-0.5	101 039 210 0401
NO.	Wire gauge(mm <sup>2</sup> )	Female	Order No.
①	0.14-0.5	M17-FC3.6G-0.5	101 039 220 0401

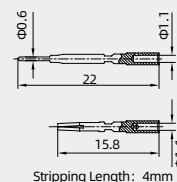

## Tools

## Crimping tool



Wire gauge	Designation	Order No.
0.09-0.82 mm <sup>2</sup>	TL03	198 001 001 0002

Notes: The tools for crimp terminal may influence the product quality and stability. Please select the tools recognized by our company.

## M17 Circular connector

63V- 3.6A

## Technical characteristics

Specifications			
Specifications	DIN EN 60 664 DIN EN 61 984		
Approvals			
Electrical data		Mechanical data	
Number of contacts	17	Housing material	copper alloy,zinc alloy
Rated current	3.6A	Housing surface	Nickel-plated
mm <sup>2</sup> / AWG	(0.14-0.5 mm <sup>2</sup> / AWG 26-20)	Contact resistance	≤ 5 mΩ
Rated voltage	63 V	Insulating bodies	PBT
Rated impulse voltage	1.5kV	Contact material	copper alloy
Pollution degree	3	Contact surface	gold plated
Flammability acc. to UL 94 V0 (UL94)		Mechanical working life	>500
Overvoltage categorie	III	Degree of protection	IP67
		Temperature range	-40°C ...+130°C

## Male, Crimp terminal

order crimp contacts separately



Contacts	Cable outlet	Designation	Order No.
17	6-9.5mm	M17-MC017-CCT/R-D9.5-SH	165 017 410 2501
	9-12mm	M17-MC017-CCT/R-D12-SH	165 017 410 2502

## Female, Crimp terminal

order crimp contacts separately



Contacts	Cable outlet	Designation	Order No.
17	6-9.5mm	M17-FC017-CCT/R-D9.5-SH	165 017 420 2504
	9-12mm	M17-FC017-CCT/R-D12-SH	165 017 420 2505

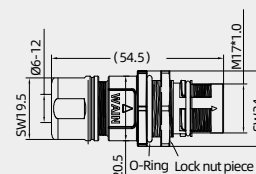

Panel cut out

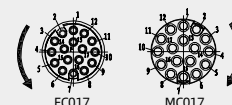

## Crimp contacts

## Crimp contacts 3.6A

3.6A



NO.	Wire gauge(mm <sup>2</sup> )	Male	Order No.
①	0.14-0.5	M17-MC3.6G-0.5	101 039 210 0401
NO.	Wire gauge(mm <sup>2</sup> )	Female	Order No.
①	0.14-0.5	M17-FC3.6G-0.5	101 039 220 0401

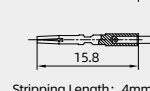
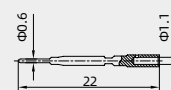

## Tools

Crimping tool



Wire gauge	Designation	Order No.
0.09-0.82 mm <sup>2</sup>	TL03	198 001 001 0002

Notes: The tools for crimp terminal may influence the product quality and stability. Please select the tools recognized by our company.



## M17 Circular connector

63V- 3.6A

## Technical characteristics

Specifications			
Specifications	DIN EN 60 664		
	DIN EN 61 984		
Approvals			
Electrical data		Mechanical data	
Number of contacts	17	Housing material	copper alloy,zinc alloy
Rated current	3.6A	Housing surface	Nickel-plated
mm <sup>2</sup> / AWG	(0.14-0.5 mm <sup>2</sup> / AWG 26-20)	Contact resistance	≤ 5 mΩ
Rated voltage	63 V	Insulating bodies	PBT
Rated impulse voltage	1.5kV	Contact material	copper alloy
Pollution degree	3	Contact surface	gold plated
Flammability acc. to UL 94 V0 (UL94)		Mechanical working life	>500
Overvoltage categorie	III	Degree of protection	IP67
		Temperature range	-40°C ...+130°C

## Male, Crimp terminal

order crimp contacts separately



Contacts	Cable outlet	Designation	Order No.
17	6-9.5mm	M17-MC017-CCT/RA-D9.5-SH	165 017 410 2503
	9-12mm	M17-MC017-CCT/RA-D12-SH	165 017 410 2504

## Female, Crimp terminal

order crimp contacts separately



Contacts	Cable outlet	Designation	Order No.
17	6-9.5mm	M17-FC017-CCT/RA-D9.5-SH	165 017 420 2506
	9-12mm	M17-FC017-CCT/RA-D12-SH	165 017 420 2507

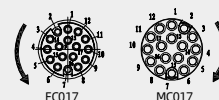
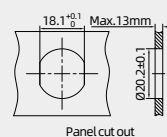
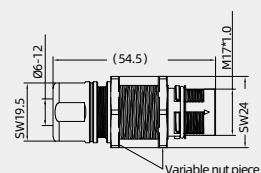

## Crimp contacts

## Crimp contacts 3.6A

3.6A



NO.	Wire gauge(mm <sup>2</sup> )	Male	Order No.
①	0.14-0.5	M17-MC3.6G-0.5	101 039 210 0401
NO.	Wire gauge(mm <sup>2</sup> )	Female	Order No.
①	0.14-0.5	M17-FC3.6G-0.5	101 039 220 0401

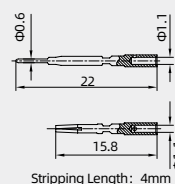

## Tools

Crimping tool



Wire gauge	Designation	Order No.
0.09-0.82 mm <sup>2</sup>	TL03	198 001 001 0002

Notes: The tools for crimp terminal may influence the product quality and stability. Please select the tools recognized by our company.

## M17 Circular connector

630V- 20A

## Technical characteristics

Specifications			
Specifications	DIN EN 60 664 DIN EN 61 984		
Approvals			
Electrical data	Mechanical data		
Number of contacts	4(3+PE)	Housing material	copper alloy,zinc alloy
Rated current	20A	Housing surface	Nickel-plated
mm <sup>2</sup> / AWG	(0.35-2.5 mm <sup>2</sup> / AWG 22-14)	Contact resistance	≤ 5 mΩ
Rated voltage	630V	Insulating bodies	PBT
Rated impulse voltage	6kV	Contact material	copper alloy
Pollution degree	3	Contact surface	gold plated
Flammability acc. to UL 94	V0 (UL94)	Mechanical working life	>500
Overvoltage categorie	III	Degree of protection	IP67
		Temperature range	-40°C ...+130°C

## Male, Crimp terminal

order crimp contacts separately

Contacts	Cable outlet	Designation	Order No.
4(3+PE)	6-9mm	M17-MC04-T-D9.5-SH	165 004 410 2500
	9-12mm	M17-MC04-T-D12-SH	165 004 410 2501



## Female, Crimp terminal

order crimp contacts separately

Contacts	Cable outlet	Designation	Order No.
4(3+PE)	6-9mm	M17-FC04-T-D9.5-SH	165 004 420 2500
	9-12mm	M17-FC04-T-D12-SH	165 004 420 2001



## Crimp contacts

## Crimp contacts 20A

Wire gauge(mm <sup>2</sup> )	Male	Order No.
0.35-2.5	M17-MC20G-2.5	101 020 210 1002

Wire gauge(mm <sup>2</sup> )	Female	Order No.
0.35-2.5	M17-FC20G-2.5	101 020 220 1002



## Tools

## Crimping tool



Wire gauge	Designation	Order No.
0.14-4 mm <sup>2</sup>	TL28-2	198 001 001 0039

Notes: The tools for crimp terminal may influence the product quality and stability. Please select the tools recognized by our company.

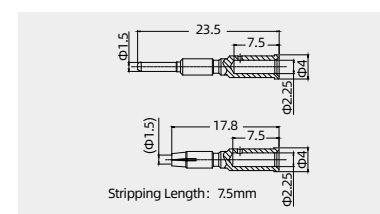
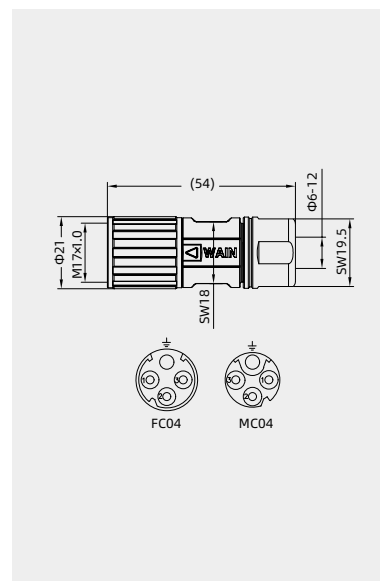
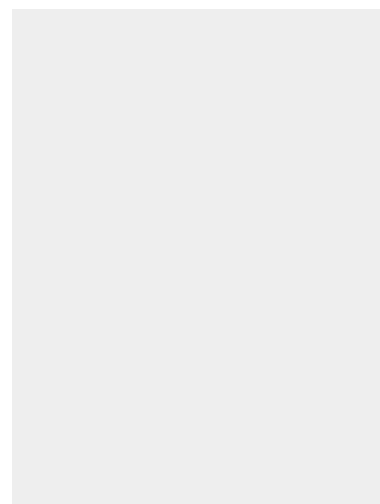

## M17 Circular connector

630V- 14A

## Technical characteristics

Specifications			
Specifications	DIN EN 60 664 DIN EN 61 984		
Approvals			
Electrical data	Mechanical data		
Number of contacts	7(6+PE)	Housing material	copper alloy,zinc alloy
Rated current	14A	Housing surface	Nickel-plated
mm <sup>2</sup> / AWG	(0.03-1.5mm <sup>2</sup> /AWG32-16)	Contact resistance	≤ 5 mΩ
Rated voltage	630 V	Insulating bodies	PBT
Rated impulse voltage	6kV	Contact material	copper alloy
Pollution degree	3	Contact surface	gold plated
Flammability acc. to UL 94	V0 (UL94)	Mechanical working life	>500
Overvoltage categorie	III	Degree of protection	IP67
		Temperature range	-40°C ...+130°C

## Crimp terminal

order crimp contacts separately

Contacts	Cable outlet	Designation	Order No.
7	6-9mm	M17-007-T-D9.5-SH	165 007 400 2007
	9-12mm	M17-007-T-D12-SH	165 007 400 2008
	6-9mm	M17-007R-T-D9.5-SH	165 007 400 2009
	9-12mm	M17-007R-T-D12-SH	165 007 400 2002
	6-9mm	M17-007/B-T-D9.5-SH	165 007 400 2005
	9-12mm	M17-007/B-T-D12-SH	165 007 400 2006
	6-9mm	M17-007R/B-T-D9.5-SH	165 007 400 2001
	9-12mm	M17-007R/B-T-D12-SH	165 007 400 2004

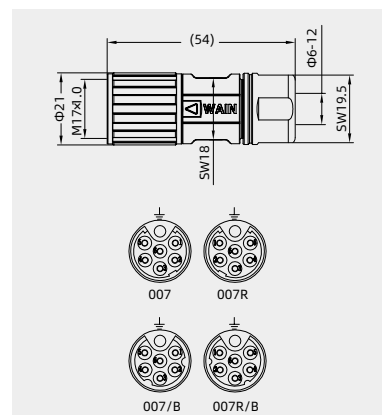
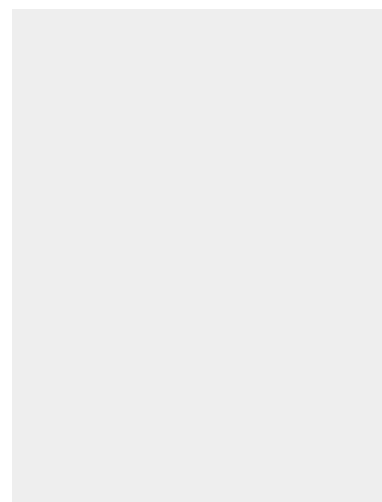

## Crimp contacts

Crimp contacts

NO.	Wire gauge(mm <sup>2</sup> )	Male	Order No.
①	0.03-0.34	M23-MC9G-0.34	101 031 210 2501
②	0.14-1.0	M23-MC9G-1.0	101 031 210 0801
③	0.5-1.5	M23-MC9G-1.5	101 031 210 0901
NO.	Wire gauge(mm <sup>2</sup> )	Female	Order No.
①	0.03-0.34	M23-FC9G-0.34	101 031 220 2501
②	0.14-1.0	M23-FC9G-1.0	101 031 220 0801
③	0.5-1.5	M23-FC9G-1.5	101 031 220 0901

NO.	Φa	Φb	Stripping Length
①	1.7	0.9	4mm
②	2.1	1.45	4mm

NO.	Φa	Φb	c	Stripping Length
①	1.7	0.9	14	4mm
②	2.1	1.45	14	4mm
③	1.75	-	16.7	4.9mm

Tools

Crimping tool



Notes: The tools for crimp terminal may influence the product quality and stability. Please select the tools recognized by our company.

Accessories

Stamped contacts

Stamped contacts



coil stock



Note: 10kpcs/volume

Tools

Terminal stamping machir



NO.	Wire gauge(mm <sup>2</sup> )	Male	Order No.
①	0.08-0.2	M23-MC9G-0.2P	101 031 210 0150
②	0.2-0.52	M23-MC9G-0.52P	101 031 210 0550
③	0.75-1.0	M23-MC9G-1.0P	101 031 210 0850
NO.	Wire gauge(mm <sup>2</sup> )	Female	Order No.
①	0.08-0.2	M23-FC9G-0.2P	101 031 220 0150
②	0.2-0.52	M23-FC9G-0.52P	101 031 220 0550
③	0.75-1.0	M23-FC9G-1.0P	101 031 220 0850

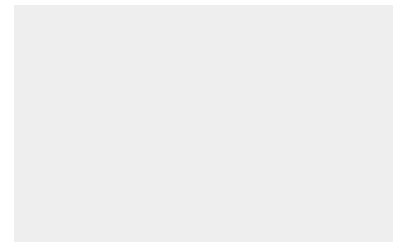
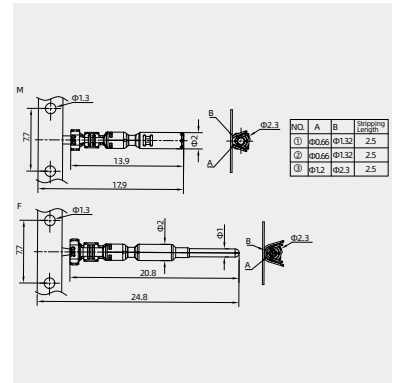

## M17 Circular connector

630/63V - 14/0.6A

## Technical characteristics

Specifications			
Specifications	DIN EN 60 664 DIN EN 61 984		
Approvals			
Electrical data		Mechanical data	
Number of contacts	5	3+PE	Housing material
Rated current	3.6	14A	Housing surface
mm <sup>2</sup> / AWG	0.14-0.5/26-20	0.03-1.5/32-16	Contact resistance
Rated voltage	63V	630V	Insulating bodies
Rated impulse voltage	1.5kV	6kV	Contact material
Pollution degree	3	3	Contact surface
Flammability acc. to UL 94	V0 (UL94)	V0 (UL94)	Mechanical working life
Overvoltage categorie	III	III	Degree of protection
			Temperature range

## Male, Crimp terminal

order crimp contacts separately



Contacts	Cable outlet	Designation	Order No.
9(5+4(3+PE))	6-9mm	M17-MC04/5-T-D9.5-SH	165 009 410 2500
	9-12mm	M17-MC04/5-T-D12-SH	165 009 410 2501

## Female, Crimp terminal

order crimp contacts separately



Contacts	Cable outlet	Designation	Order No.
9(5+4(3+PE))	6-9mm	M17-FC04/5-T-D9.5-SH	165 009 420 2502
	9-12mm	M17-FC04/5-T-D12-SH	165 009 420 2500

## Crimp contacts

## Crimp contacts 3.6A

3.6A(signal)



NO.	Wire gauge(mm <sup>2</sup> )	Male	Order No.
①	0.14-0.5	M17-MC3.6G-0.5	101 039 210 0401

NO.	Wire gauge(mm <sup>2</sup> )	Female	Order No.
①	0.14-0.5	M17-FC3.6G-0.5	101 039 220 0401

## Crimp contacts

power



NO.	Wire gauge(mm <sup>2</sup> )	Male	Order No.
①	0.03-0.34	M23-MC9G-0.34	101 031 210 2501
②	0.14-1.0	M23-MC9G-1.0	101 031 210 0801
③	0.5-1.5	M23-MC9G-1.5	101 031 210 0901

NO.	Wire gauge(mm <sup>2</sup> )	Female	Order No.
①	0.03-0.34	M23-FC9G-0.34	101 031 220 2501
②	0.14-1.0	M23-FC9G-1.0	101 031 220 0801
③	0.5-1.5	M23-FC9G-1.5	101 031 220 0901

## Tools

Crimping tool



Wire gauge	Designation	Order No.
0.09-0.82 mm <sup>2</sup>	TL03	198 001 001 0002

## Tools

Crimping tool



Wire gauge	Designation	Order No.
0.14-4 mm <sup>2</sup>	TL28-2	198 001 001 0039

Notes: The tools for crimp terminal may influence the product quality and stability. Please select the tools recognized by our company.

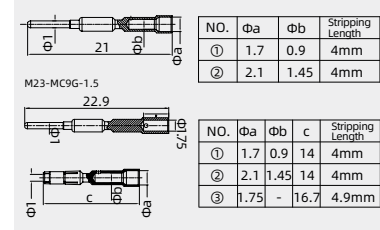
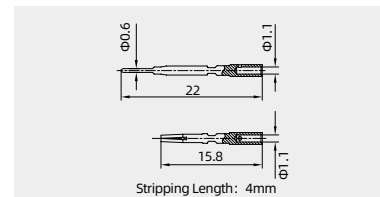
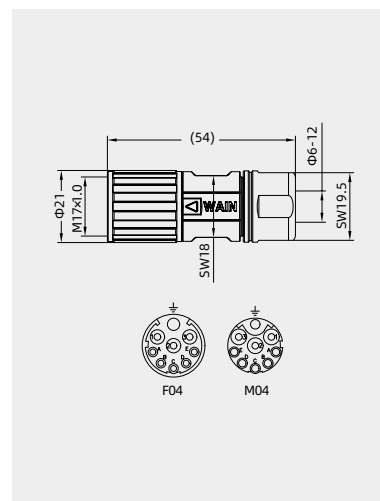
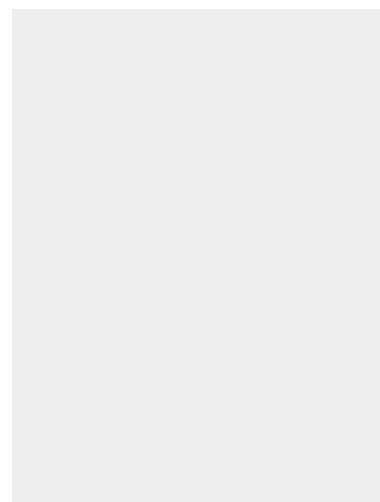

Accessories

Stamped contacts

Stamped contacts



NO.	Wire gauge(mm <sup>2</sup> )	Male	Order No.
①	0.08-0.2	M23-MC9G-0.2P	101 031 210 0150
②	0.2-0.52	M23-MC9G-0.52P	101 031 210 0550
③	0.75-1.0	M23-MC9G-1.0P	101 031 210 0850
NO.	Wire gauge(mm <sup>2</sup> )	Female	Order No.
①	0.08-0.2	M23-FC9G-0.2P	101 031 220 0150
②	0.2-0.52	M23-FC9G-0.52P	101 031 220 0550
③	0.75-1.0	M23-FC9G-1.0P	101 031 220 0850

coil stock



Note: 10kpcs/volume

Tools

Terminal stamping machir



Wire gauge	Designation	Order No.
	M23-XC9G-MJ	903 020 000 0548

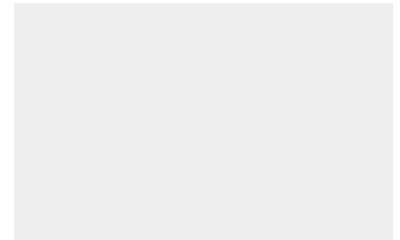
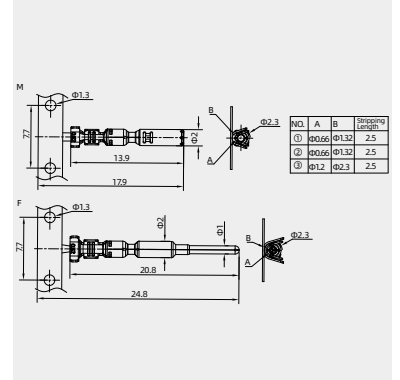

## M17 Circular connector

48V- 7.5A

## Technical characteristics

Specifications			
Specifications	DIN EN 60 664 DIN EN 61 984		
Approvals			
Electrical data	Mechanical data		
Number of contacts	10	Housing material	copper alloy,zinc alloy
Rated current	7.5A	Housing surface	Nickel-plated
mm <sup>2</sup> / AWG	(0.09-0.82mm <sup>2</sup> / AWG 28-18)	Contact resistance	≤ 10 mΩ
Rated voltage	48 V	Insulating bodies	PBT
Rated impulse voltage	1.5kV	Contact material	copper alloy
Pollution degree	3	Contact surface	gold plated
Flammability acc. to UL 94	V0 (UL94)	Mechanical working life	>500
Overvoltage categorie	III	Degree of protection	IP67
		Temperature range	-40°C ...+130°C

## Crimp terminal

order crimp contacts separately

Contacts	Cable outlet	Designation	Order No.
10	6-9.5mm	M17-FC010-T-D9.5-SH	165 010 420 2001
	9-12mm	M17-FC010-T-D12-SH	165 010 420 2500

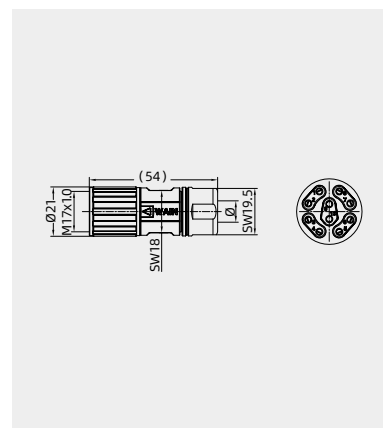
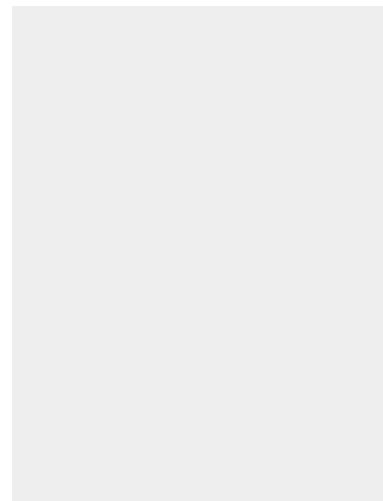

## Accessories

## Crimp contacts 5A

gold plated



Wire gauge(mm <sup>2</sup> )	Female	Order No.
0.09-0.25	CSGF-0.25	101 014 220 0101
0.13-0.33	CSGF-0.33	101 014 220 0201
0.33-0.52	CSGF-0.52	101 014 220 0501
0.33-0.82	CSGF-0.82	101 014 220 0701

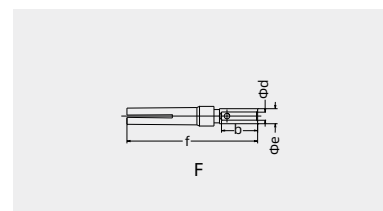

## Tools

Crimping tool



Wire gauge	Designation	Order No.
0.09-0.82mm <sup>2</sup>	TL03	198 001 001 0002

Notes: The tools for crimp terminal may influence the product quality and stability. Please select the tools recognized by our company.

## M17 Circular connector

32V- 7A

## Technical characteristics

Specifications			
Specifications	DIN EN 60 664		
	DIN EN 61 984		
Approvals			
Electrical data		Mechanical data	
Number of contacts	12	Housing material	copper alloy,zinc alloy
Rated current	7A	Housing surface	Nickel-plated
mm <sup>2</sup> / AWG	(0.03-1.0mm <sup>2</sup> /AWG32-18)	Contact resistance	≤ 5 mΩ
Rated voltage	32 V	Insulating bodies	PBT
Rated impulse voltage	1.5kV	Contact material	copper alloy
Pollution degree	3	Contact surface	gold plated
Flammability acc. to UL 94	V0 (UL94)	Mechanical working life	>500
Overtoltage categorie	III	Degree of protection	IP67
		Temperature range	-40°C ...+130°C

## Crimp terminal

order crimp contacts separately

Contacts	Cable outlet	Designation	Order No.
12	6-9mm	M17-012R-T-D9.5-SH	165 012 400 2003
	9-12mm	M17-012R-T-D12-SH	165 012 400 2001

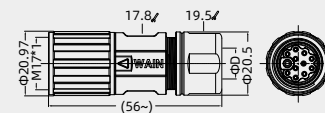

## Crimp contacts

Crimp contacts

NO.	Wire gauge(mm <sup>2</sup> )	Male	Order No.
①	0.03-0.34	M23-MC9G-0.34	101 031 210 2501
②	0.14-1.0	M23-MC9G-1.0	101 031 210 0801
NO.	Wire gauge(mm <sup>2</sup> )	Female	Order No.
①	0.03-0.34	M23-FC9G-0.34	101 031 220 2501
②	0.14-1.0	M23-FC9G-1.0	101 031 220 0801

NO.	Φa	Φb	Stripping Length
①	1.7	0.9	4mm
②	2.1	1.45	4mm

NO.	Φa	Φb	c	Stripping Length
①	1.7	0.9	14	4mm
②	2.1	1.45	14	4mm

Tools

Crimping tool

Wire gauge	Designation	Order No.
0.14-4 mm <sup>2</sup>	TL28-2	198 001 001 0039



Notes: The tools for crimp terminal may influence the product quality and stability. Please select the tools recognized by our company.



Accessories

Stamped contacts

Stamped contacts



coil stock



Note: 10kpcs/volume

NO.	Wire gauge(mm <sup>2</sup> )	Male	Order No.
①	0.08-0.2	M23-MC9G-0.2P	101 031 210 0150
②	0.2-0.52	M23-MC9G-0.52P	101 031 210 0550
③	0.75-1.0	M23-MC9G-1.0P	101 031 210 0850
NO.	Wire gauge(mm <sup>2</sup> )	Female	Order No.
①	0.08-0.2	M23-FC9G-0.2P	101 031 220 0150
②	0.2-0.52	M23-FC9G-0.52P	101 031 220 0550
③	0.75-1.0	M23-FC9G-1.0P	101 031 220 0850

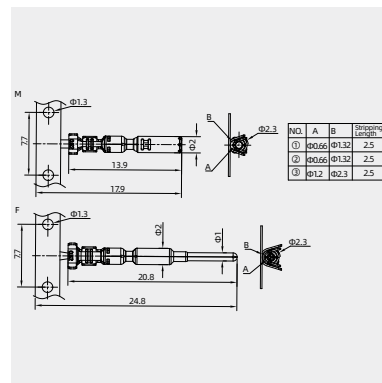

Tools

Terminal stamping machir



Wire gauge	Designation	Order No.
	M23-XC9G-MJ	903 020 000 0548

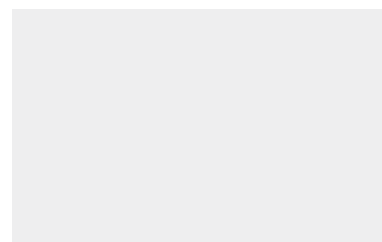

## M17 Circular connector

63V- 3.6A

## Technical characteristics

Specifications			
Specifications	DIN EN 60 664		
	DIN EN 61 984		
Approvals			
Electrical data		Mechanical data	
Number of contacts	17	Housing material	copper alloy,zinc alloy
Rated current	3.6A	Housing surface	Nickel-plated
mm <sup>2</sup> / AWG	(0.14-0.5 mm <sup>2</sup> / AWG 26-20)	Contact resistance	≤ 5 mΩ
Rated voltage	63 V	Insulating bodies	PBT
Rated impulse voltage	1.5kV	Contact material	copper alloy
Pollution degree	3	Contact surface	gold plated
Flammability acc. to UL 94 V0 (UL94)		Mechanical working life	>500
Overvoltage categorie	III	Degree of protection	IP67
		Temperature range	-40°C ...+130°C

## Male, Crimp terminal

order crimp contacts separately



Contacts	Cable outlet	Designation	Order No.
17	6-9mm	M17-MC017-T-D9.5-SH	165 017 410 2001
	9-12mm	M17-MC017-T-D12-SH	165 017 410 2002

## Female, Crimp terminal

order crimp contacts separately



Contacts	Cable outlet	Designation	Order No.
17	6-9mm	M17-FC017-T-D9.5-SH	165 017 420 2002
	9-12mm	M17-FC017-T-D12-SH	165 017 420 2001

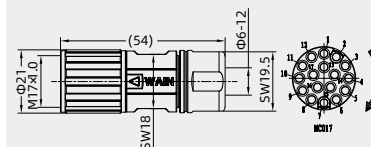

## Crimp contacts

## Crimp contacts 3.6A

3.6A



NO.	Wire gauge(mm <sup>2</sup> )	Male	Order No.
①	0.14-0.5	M17-MC3.6G-0.5	101 039 210 0401
NO.	Wire gauge(mm <sup>2</sup> )	Female	Order No.
①	0.14-0.5	M17-FC3.6G-0.5	101 039 220 0401

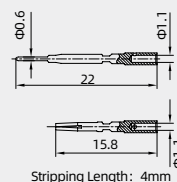

## Tools

Crimping tool



Wire gauge	Designation	Order No.
0.09-0.82 mm <sup>2</sup>	TL03	198 001 001 0002

Notes: The tools for crimp terminal may influence the product quality and stability. Please select the tools recognized by our company.

## M17 Circular connector

630V- 20A

## Technical characteristics

Specifications			
Specifications	DIN EN 60 664 DIN EN 61 984		
Approvals			
Electrical data	Mechanical data		
Number of contacts	4(3+PE)	Housing material	copper alloy,zinc alloy
Rated current	20A	Housing surface	Nickel-plated
mm <sup>2</sup> / AWG	(0.35-2.5 mm <sup>2</sup> / AWG 22-14)	Contact resistance	≤ 5 mΩ
Rated voltage	630V	Insulating bodies	PBT
Rated impulse voltage	6kV	Contact material	copper alloy
Pollution degree	3	Contact surface	gold plated
Flammability acc. to UL 94	V0 (UL94)	Mechanical working life	>500
Overvoltage categorie	III	Degree of protection	IP67
		Temperature range	-40°C ...+130°C

## Male, Crimp terminal

order crimp contacts separately



Contacts	Designation	Order No.
4(3+PE)	M17-MC04-BK21.6-OD2.7	165 004 310 1001

## Female, Crimp terminal

order crimp contacts separately



Contacts	Designation	Order No.
4(3+PE)	M17-FC04-BK21.6-OD2.7	165 004 320 2500

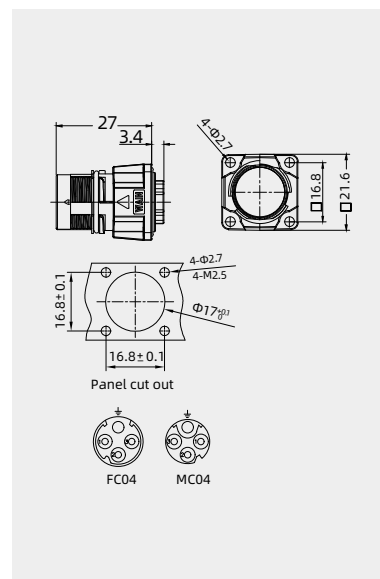
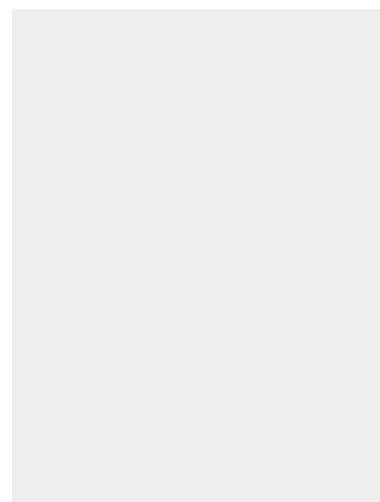

## Crimp contacts

## Crimp contacts 20A

Wire gauge(mm <sup>2</sup> )	Male	Order No.
0.35-2.5	M17-MC20G-2.5	101 020 210 1002



Wire gauge(mm <sup>2</sup> )	Female	Order No.
0.35-2.5	M17-FC20G-2.5	101 020 220 1002

## Tools

## Crimping tool



Wire gauge	Designation	Order No.
0.14-4 mm <sup>2</sup>	TL28-2	198 001 001 0039

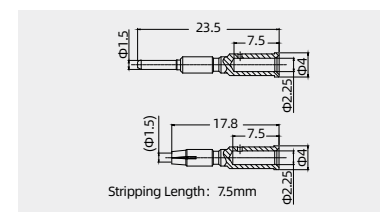

Notes: The tools for crimp terminal may influence the product quality and stability. Please select the tools recognized by our company.

## M17 Circular connector

630V- 20A

## Technical characteristics

## Specifications

Specifications	DIN EN 60 664
	DIN EN 61 984

## Approvals

Electrical data		Mechanical data	
Number of contacts	4(3+PE)	Housing material	copper alloy,zinc alloy
Rated current	20A	Housing surface	Nickel-plated
mm <sup>2</sup> / AWG	(0.35-2.5 mm <sup>2</sup> / AWG 22-14)	Contact resistance	≤ 5 mΩ
Rated voltage	630V	Insulating bodies	PBT
Rated impulse voltage	6kV	Contact material	copper alloy
Pollution degree	3	Contact surface	gold plated
Flammability acc. to UL 94	V0 (UL94)	Mechanical working life	>500
Overvoltage categorie	III	Degree of protection	IP67
		Temperature range	-40°C ...+130°C

## Male, Crimp terminal

order crimp contacts separately



Contacts	Designation	Order No.
4(3+PE)	M17-MC04-BKR-M20	165 004 310 1500

## Female, Crimp terminal

order crimp contacts separately



Contacts	Designation	Order No.
4(3+PE)	M17-FC04-BKR-M20	165 004 320 1500

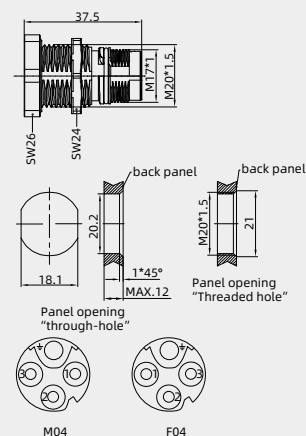

## Crimp contacts

## Crimp contacts 20A

Wire gauge(mm <sup>2</sup> )	Male	Order No.
0.35-2.5	M17-MC20G-2.5	101 020 210 1002



Wire gauge(mm <sup>2</sup> )	Female	Order No.
0.35-2.5	M17-FC20G-2.5	101 020 220 1002

## Tools

## Crimping tool



Wire gauge	Designation	Order No.
0.14-4 mm <sup>2</sup>	TL28-2	198 001 001 0039

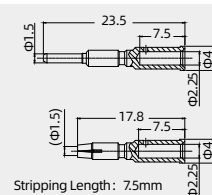

Notes: The tools for crimp terminal may influence the product quality and stability. Please select the tools recognized by our company.



## M17 Circular connector

630V- 14A

## Technical characteristics

Specifications		Mechanical data	
Specifications	DIN EN 60 664 DIN EN 61 984	Housing material	copper alloy,zinc alloy
Approvals			
Electrical data		Housing surface	Nickel-plated
Number of contacts	7(6+PE)	Contact resistance	≤ 5 mΩ
Rated current	14A	Insulating bodies	PBT
mm <sup>2</sup> / AWG	(0.03-1.5 mm <sup>2</sup> / AWG 32-16)	Contact material	copper alloy
Rated voltage	630 V	Contact surface	gold plated
Rated impulse voltage	6kV	Mechanical working life	>500
Pollution degree	3	Degree of protection	IP67
Flammability acc. to UL 94	V0 (UL94)	Temperature range	-40°C ...+130°C
Overvoltage categorie	III		

## Crimp terminal

order crimp contacts separately



Contacts	Designation	Order No.
7	M17-007-BK21.6-OD2.7	165 007 300 4003
	M17-007R-BK21.6-OD2.7	165 007 300 4015
	M17-007/B-BK21.6-OD2.7	165 007 300 4016
	M17-007R/B-BK21.6-OD2.7	165 007 300 4017

## Crimp terminal

order crimp contacts separately



Contacts	Designation	Order No.
7	M17-007-BKR-M20	165 007 310 1500
	M17-007R-BKR-M20	165 007 320 1500
	M17-007/B-BKR-M20	165 007 310 1501
	M17-007R/B-BKR-M20	165 007 320 1501

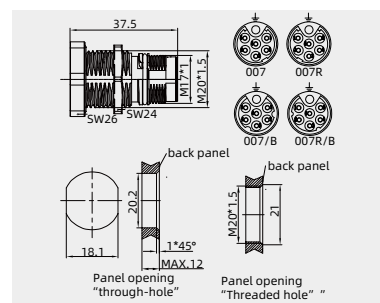
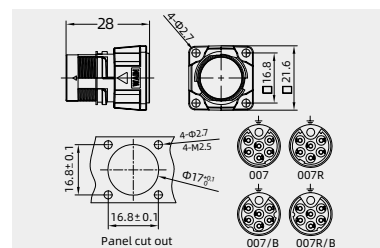
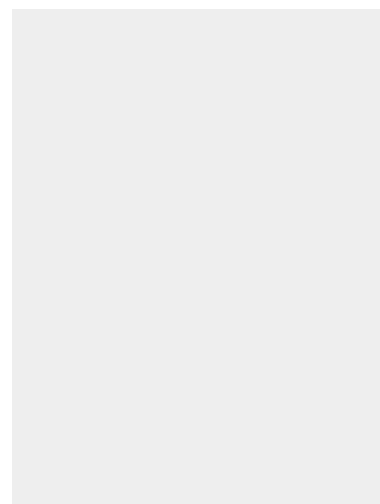

## Crimp contacts

Crimp contacts



NO.	Wire gauge(mm <sup>2</sup> )	Male	Order No.
①	0.03-0.34	M23-MC9G-0.34	101 031 210 2501
②	0.14-1.0	M23-MC9G-1.0	101 031 210 0801
③	0.5-1.5	M23-MC9G-1.5	101 031 210 0901
NO.	Wire gauge(mm <sup>2</sup> )	Female	Order No.
①	0.03-0.34	M23-FC9G-0.34	101 031 220 2501
②	0.14-1.0	M23-FC9G-1.0	101 031 220 0801
③	0.5-1.5	M23-FC9G-1.5	101 031 220 0901

## Tools

Crimping tool



Wire gauge	Designation	Order No.
0.14-4 mm <sup>2</sup>	TL28-2	198 001 001 0039

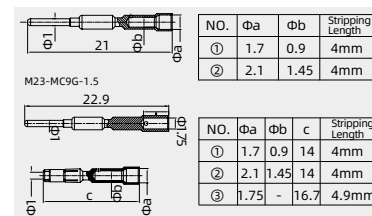

Notes: The tools for crimp terminal may influence the product quality and stability. Please select the tools recognized by our company.

Accessories

Stamped contacts

Stamped contacts



coil stock



Note: 10kpcs/volume

NO.	Wire gauge(mm <sup>2</sup> )	Male	Order No.
①	0.08-0.2	M23-MC9G-0.2P	101 031 210 0150
②	0.2-0.52	M23-MC9G-0.52P	101 031 210 0550
③	0.75-1.0	M23-MC9G-1.0P	101 031 210 0850
NO.	Wire gauge(mm <sup>2</sup> )	Female	Order No.
①	0.08-0.2	M23-FC9G-0.2P	101 031 220 0150
②	0.2-0.52	M23-FC9G-0.52P	101 031 220 0550
③	0.75-1.0	M23-FC9G-1.0P	101 031 220 0850

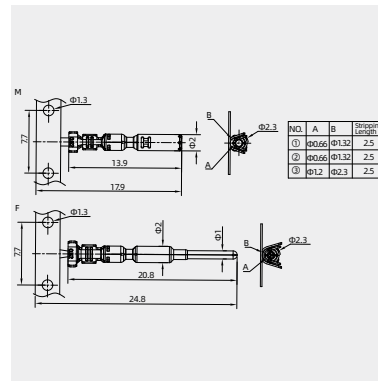

Tools

Terminal stamping machir



Wire gauge	Designation	Order No.
	M23-XC9G-MJ	903 020 000 0548

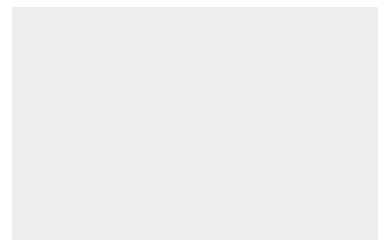

## M17 Circular connector

630V- 14A

## Technical characteristics

Specifications			
Specifications	DIN EN 60 664 DIN EN 61 984		
Approvals			
Electrical data	Mechanical data		
Number of contacts	7(6+PE)	Housing material	copper alloy,zinc alloy
Rated current	14A	Housing surface	Nickel-plated
mm <sup>2</sup> / AWG	(0.03-1.5 mm <sup>2</sup> / AWG 32-16)	Contact resistance	≤ 5 mΩ
Rated voltage	630 V	Insulating bodies	PBT
Rated impulse voltage	6kV	Contact material	copper alloy
Pollution degree	3	Contact surface	gold plated
Flammability acc. to UL 94	V0 (UL94)	Mechanical working life	>500
Overvoltage categorie	III	Degree of protection	IP67
		Temperature range	-40°C ...+130°C

## Crimp terminal



order crimp contacts separately



Contacts	Designation	Order No.
7	M17-007-BK-M17	165 007 300 1500
	M17-007R-BK-M17	165 007 300 1501
	M17-007/B-BK-M17	165 007 300 1502
	M17-007R/B-BK-M17	165 007 300 1503

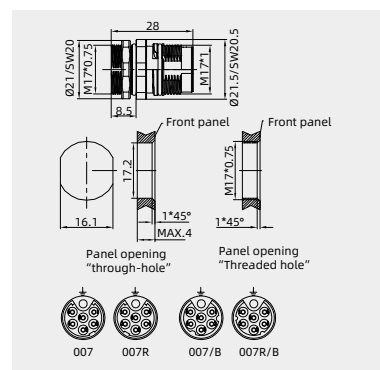

## Crimp contacts

## Crimp contacts



NO.	Wire gauge(mm <sup>2</sup> )	Male	Order No.
①	0.03-0.34	M23-MC9G-0.34	101 031 210 2501
②	0.14-1.0	M23-MC9G-1.0	101 031 210 0801
③	0.5-1.5	M23-MC9G-1.5	101 031 210 0901
NO.	Wire gauge(mm <sup>2</sup> )	Female	Order No.
①	0.03-0.34	M23-FC9G-0.34	101 031 220 2501
②	0.14-1.0	M23-FC9G-1.0	101 031 220 0801
③	0.5-1.5	M23-FC9G-1.5	101 031 220 0901

## Tools

## Crimping tool



Wire gauge	Designation	Order No.
0.14-4 mm <sup>2</sup>	TL28-2	198 001 001 0039

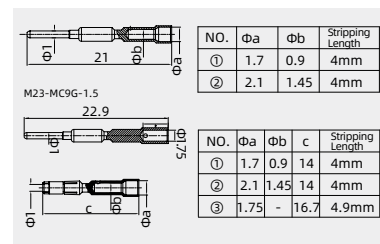

Notes: The tools for crimp terminal may influence the product quality and stability. Please select the tools recognized by our company.



Accessories

Stamped contacts

Stamped contacts



coil stock



Note: 10kpcs/volume

NO.	Wire gauge(mm <sup>2</sup> )	Male	Order No.
①	0.08-0.2	M23-MC9G-0.2P	101 031 210 0150
②	0.2-0.52	M23-MC9G-0.52P	101 031 210 0550
③	0.75-1.0	M23-MC9G-1.0P	101 031 210 0850
NO.	Wire gauge(mm <sup>2</sup> )	Female	Order No.
①	0.08-0.2	M23-FC9G-0.2P	101 031 220 0150
②	0.2-0.52	M23-FC9G-0.52P	101 031 220 0550
③	0.75-1.0	M23-FC9G-1.0P	101 031 220 0850

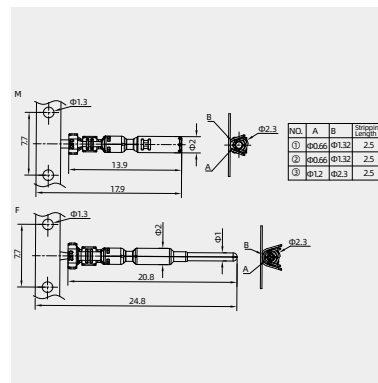

Tools

Terminal stamping machir



Wire gauge	Designation	Order No.
	M23-XC9G-MJ	903 020 000 0548

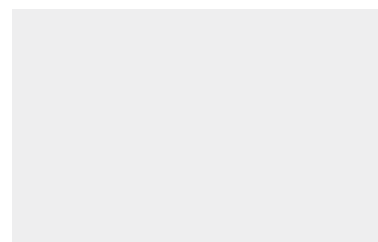

## M17 Circular connector

630/63V - 14/0.6A

## Technical characteristics

Specifications			
Specifications	DIN EN 60 664 DIN EN 61 984		
Approvals			
Electrical data		Mechanical data	
Number of contacts	5	3+PE	Housing material
Rated current	3.6	14A	Housing surface
mm <sup>2</sup> / AWG	0.14-0.5/26-20	0.03-1.5/32-16	Contact resistance
Rated voltage	63V	630V	Insulating bodies
Rated impulse voltage	1.5kV	6kV	Contact material
Pollution degree	3	3	Contact surface
Flammability acc. to UL 94	V0 (UL94)	V0 (UL94)	Mechanical working life
Overvoltage categorie	III	III	Degree of protection
			Temperature range

## Male, Crimp terminal

order crimp contacts separately



Contacts	Designation	Order No.
9(5+4(3+PE))	M17-MC04/5-BK21.6-OD2.7	165 009 310 2501

## Female, Crimp terminal

order crimp contacts separately



Contacts	Designation	Order No.
9(5+4(3+PE))	M17-FC04/5-BK21.6-OD2.7	165 009 320 2500

## Crimp contacts

## Crimp contacts 3.6A

3.6A(signal)



NO.	Wire gauge(mm <sup>2</sup> )	Male	Order No.
①	0.14-0.5	M17-MC3.6G-0.5	101 039 210 0401

NO.	Wire gauge(mm <sup>2</sup> )	Female	Order No.
①	0.14-0.5	M17-FC3.6G-0.5	101 039 220 0401

## Crimp contacts

power



NO.	Wire gauge(mm <sup>2</sup> )	Male	Order No.
①	0.03-0.34	M23-MC9G-0.34	101 031 210 2501
②	0.14-1.0	M23-MC9G-1.0	101 031 210 0801
③	0.5-1.5	M23-MC9G-1.5	101 031 210 0901

NO.	Wire gauge(mm <sup>2</sup> )	Female	Order No.
①	0.03-0.34	M23-FC9G-0.34	101 031 220 2501
②	0.14-1.0	M23-FC9G-1.0	101 031 220 0801
③	0.5-1.5	M23-FC9G-1.5	101 031 220 0901

## Tools

Crimping tool



Wire gauge	Designation	Order No.
0.09-0.82 mm <sup>2</sup>	TL03	198 001 001 0002

## Tools

Crimping tool



Wire gauge	Designation	Order No.
0.14-4 mm <sup>2</sup>	TL28-2	198 001 001 0039

Notes: The tools for crimp terminal may influence the product quality and stability. Please select the tools recognized by our company.

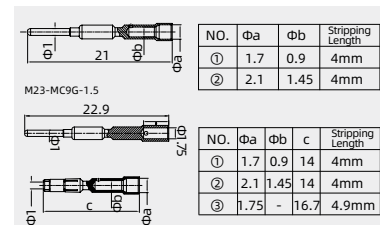
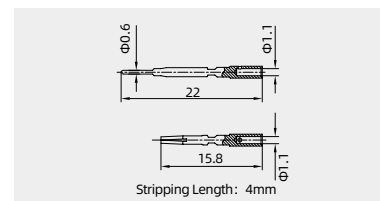
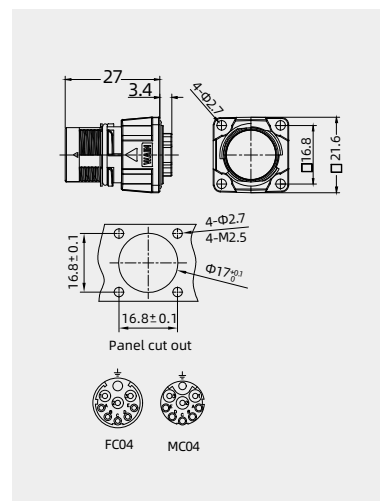
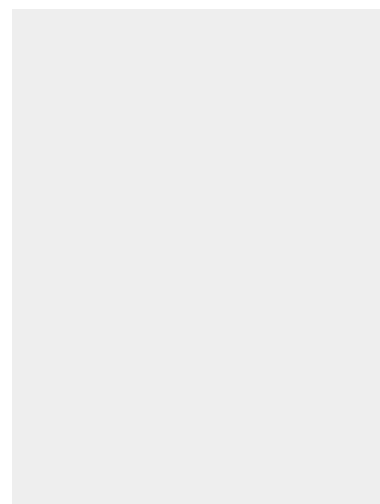

Accessories

Stamped contacts

Stamped contacts



coil stock



Note: 10kpcs/volume

NO.	Wire gauge(mm <sup>2</sup> )	Male	Order No.
①	0.08-0.2	M23-MC9G-0.2P	101 031 210 0150
②	0.2-0.52	M23-MC9G-0.52P	101 031 210 0550
③	0.75-1.0	M23-MC9G-1.0P	101 031 210 0850

NO.	Wire gauge(mm <sup>2</sup> )	Female	Order No.
①	0.08-0.2	M23-FC9G-0.2P	101 031 220 0150
②	0.2-0.52	M23-FC9G-0.52P	101 031 220 0550
③	0.75-1.0	M23-FC9G-1.0P	101 031 220 0850

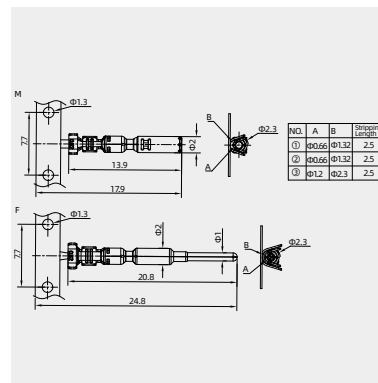

Tools

Terminal stamping machir



Wire gauge	Designation	Order No.
	M23-XC9G-MJ	903 020 000 0548

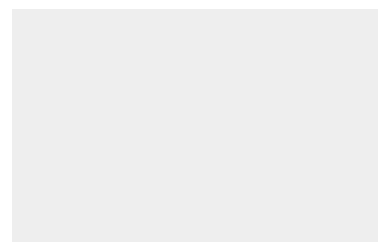

## M17 Circular connector

630/63V - 14/0.6A

## Technical characteristics

Specifications			
Specifications	DIN EN 60 664 DIN EN 61 984		
Approvals			
Electrical data		Mechanical data	
Number of contacts	5	3+PE	Housing material
Rated current	3.6	14A	Housing surface
mm <sup>2</sup> / AWG	0.14-0.5/26-20	0.03-1.5/32-16	Contact resistance
Rated voltage	63V	630V	Insulating bodies
Rated impulse voltage	1.5kV	6kV	Contact material
Pollution degree	3	3	Contact surface
Flammability acc. to UL 94	V0 (UL94)	V0 (UL94)	Mechanical working life
Overvoltage categorie	III	III	Degree of protection
			Temperature range



## Male, Crimp terminal

order crimp contacts separately



Contacts	Designation	Order No.
9(5+4(3+PE))	M17-MC04/5-BKR-M20	165 009 310 1500

## Female, Crimp terminal

order crimp contacts separately



Contacts	Designation	Order No.
9(5+4(3+PE))	M17-FC04/5-BKR-M20	165 009 320 1500

## Crimp contacts

## Crimp contacts 3.6A

3.6A(signal)



NO.	Wire gauge(mm <sup>2</sup> )	Male	Order No.
①	0.14-0.5	M17-MC3.6G-0.5	101 039 210 0401

NO.	Wire gauge(mm <sup>2</sup> )	Female	Order No.
①	0.14-0.5	M17-FC3.6G-0.5	101 039 220 0401

## Crimp contacts

power



NO.	Wire gauge(mm <sup>2</sup> )	Male	Order No.
①	0.03-0.34	M23-MC9G-0.34	101 031 210 2501
②	0.14-1.0	M23-MC9G-1.0	101 031 210 0801
③	0.5-1.5	M23-MC9G-1.5	101 031 210 0901

NO.	Wire gauge(mm <sup>2</sup> )	Female	Order No.
①	0.03-0.34	M23-FC9G-0.34	101 031 220 2501
②	0.14-1.0	M23-FC9G-1.0	101 031 220 0801
③	0.5-1.5	M23-FC9G-1.5	101 031 220 0901

## Tools

Crimping tool



Wire gauge	Designation	Order No.
0.09-0.82 mm <sup>2</sup>	TL03	198 001 001 0002

## Tools

Crimping tool



Wire gauge	Designation	Order No.
0.14-4 mm <sup>2</sup>	TL28-2	198 001 001 0039

Notes: The tools for crimp terminal may influence the product quality and stability. Please select the tools recognized by our company.

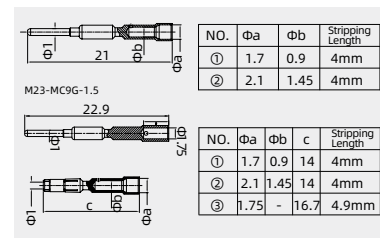
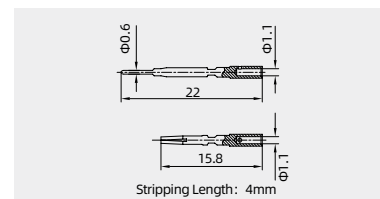
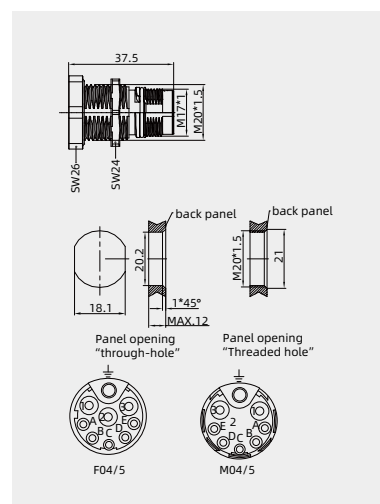
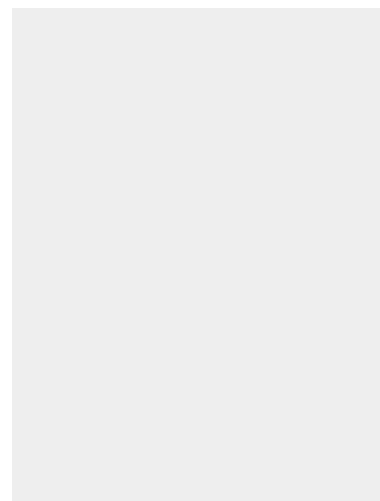

Accessories

Stamped contacts

Stamped contacts



coil stock



Note: 10kpcs/volume

NO.	Wire gauge(mm <sup>2</sup> )	Male	Order No.
①	0.08-0.2	M23-MC9G-0.2P	101 031 210 0150
②	0.2-0.52	M23-MC9G-0.52P	101 031 210 0550
③	0.75-1.0	M23-MC9G-1.0P	101 031 210 0850
NO.	Wire gauge(mm <sup>2</sup> )	Female	Order No.
①	0.08-0.2	M23-FC9G-0.2P	101 031 220 0150
②	0.2-0.52	M23-FC9G-0.52P	101 031 220 0550
③	0.75-1.0	M23-FC9G-1.0P	101 031 220 0850

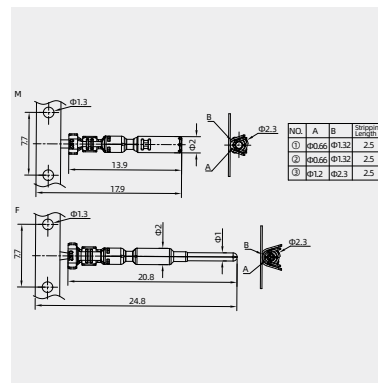

Tools

Terminal stamping machir



Wire gauge	Designation	Order No.
	M23-XC9G-MJ	903 020 000 0548

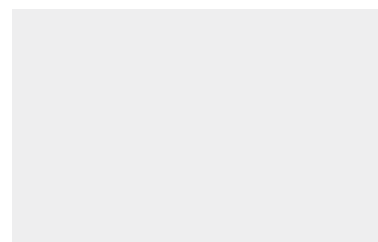

# M17 Circular connector

630/63V - 14/0.6A

## Technical characteristics

Specifications			
Specifications	DIN EN 60 664 DIN EN 61 984		
Approvals			
Electrical data		Mechanical data	
Number of contacts	5	3+PE	Housing material
Rated current	3.6	14A	Housing surface
mm <sup>2</sup> / AWG	0.14-0.5/26-20	0.03-1.5/32-16	Contact resistance
Rated voltage	63V	630V	Insulating bodies
Rated impulse voltage	1.5kV	6kV	Contact material
Pollution degree	3	3	Contact surface
Flammability acc. to UL 94	V0 (UL94)	V0 (UL94)	Mechanical working life
Overvoltage categorie	III	III	Degree of protection
			Temperature range



### Male, Crimp terminal

order crimp contacts separately



Contacts	Designation	Order No.
9(5+4(3+PE))	M17-MC04/5-BK-M17	165 009 310 1502

### Female, Crimp terminal

order crimp contacts separately



Contacts	Designation	Order No.
9(5+4(3+PE))	M17-FC04/5-BK-M17	165 009 320 1502

## Crimp contacts

### Crimp contacts 3.6A

3.6A(signal)



NO.	Wire gauge(mm <sup>2</sup> )	Male	Order No.
①	0.14-0.5	M17-MC3.6G-0.5	101 039 210 0401
NO.	Wire gauge(mm <sup>2</sup> )	Female	Order No.
①	0.14-0.5	M17-FC3.6G-0.5	101 039 220 0401

### Crimp contacts

power



NO.	Wire gauge(mm <sup>2</sup> )	Male	Order No.
①	0.03-0.34	M23-MC9G-0.34	101 031 210 2501
②	0.14-1.0	M23-MC9G-1.0	101 031 210 0801
③	0.5-1.5	M23-MC9G-1.5	101 031 210 0901
NO.	Wire gauge(mm <sup>2</sup> )	Female	Order No.
①	0.03-0.34	M23-FC9G-0.34	101 031 220 2501
②	0.14-1.0	M23-FC9G-1.0	101 031 220 0801
③	0.5-1.5	M23-FC9G-1.5	101 031 220 0901

### Tools

Crimping tool



Wire gauge	Designation	Order No.
0.09-0.82 mm <sup>2</sup>	TL03	198 001 001 0002

### Tools

Crimping tool



Wire gauge	Designation	Order No.
0.14-4 mm <sup>2</sup>	TL28-2	198 001 001 0039

Notes: The tools for crimp terminal may influence the product quality and stability. Please select the tools recognized by our company.

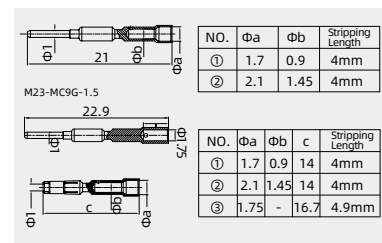
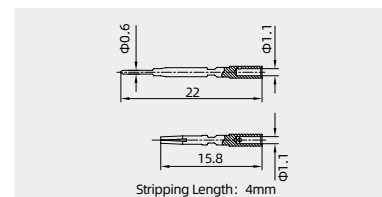
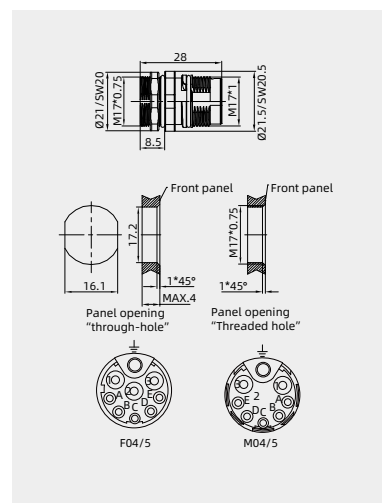
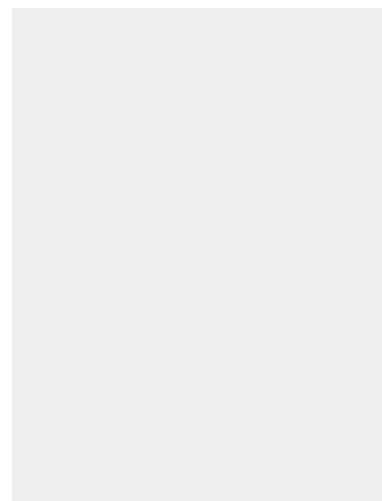

Accessories

Stamped contacts

Stamped contacts



coil stock



Note: 10kpcs/volume

NO.	Wire gauge(mm <sup>2</sup> )	Male	Order No.
①	0.08-0.2	M23-MC9G-0.2P	101 031 210 0150
②	0.2-0.52	M23-MC9G-0.52P	101 031 210 0550
③	0.75-1.0	M23-MC9G-1.0P	101 031 210 0850

NO.	Wire gauge(mm <sup>2</sup> )	Female	Order No.
①	0.08-0.2	M23-FC9G-0.2P	101 031 220 0150
②	0.2-0.52	M23-FC9G-0.52P	101 031 220 0550
③	0.75-1.0	M23-FC9G-1.0P	101 031 220 0850

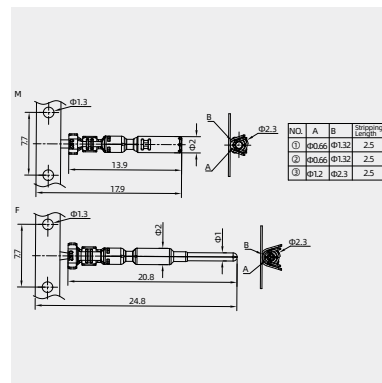

Tools

Terminal stamping machir



Wire gauge	Designation	Order No.
	M23-XC9G-MJ	903 020 000 0548

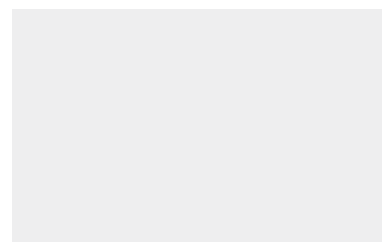

## M17 Circular connector

48V- 7.5A

## Technical characteristics

Specifications		Mechanical data	
Specifications	DIN EN 60 664 DIN EN 61 984	Housing material	copper alloy,zinc alloy
Approvals		Housing surface	Nickel-plated
Electrical data		Contact resistance	≤ 10 mΩ
Number of contacts	10	Insulating bodies	PBT
Rated current	7.5A	Contact material	copper alloy
mm <sup>2</sup> / AWG	(0.09-0.82mm <sup>2</sup> / AWG 28-18)	Contact surface	gold plated
Rated voltage	48 V	Mechanical working life	>500
Rated impulse voltage	1.5kV	Degree of protection	IP67
Pollution degree	3	Temperature range	-40°C ...+130°C
Flammability acc. to UL 94	V0 (UL94)		
Overvoltage categorie	III		

## Crimp terminal

order crimp contacts separately

Contacts	Designation	Order No.
10	M17-MC010-BK21.6-OD2.7	165 010 310 1500

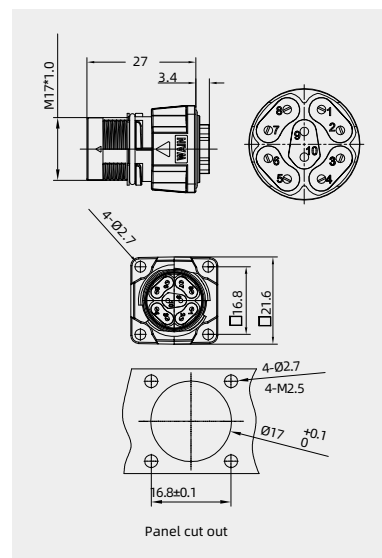
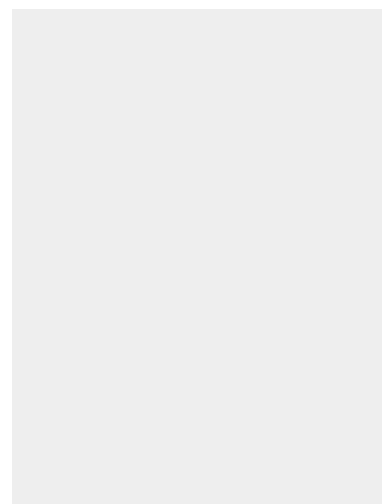

## Accessories

## Crimp contacts 5A

gold plated



Wire gauge(mm <sup>2</sup> )	Male	Order No.
0.09-0.25	CSGM-0.25	101 014 210 0101
0.13-0.33	CSGM-0.33	101 014 210 0201
0.33-0.52	CSGM-0.52	101 014 210 0501
0.33-0.82	CSGM-0.82	101 014 210 0701

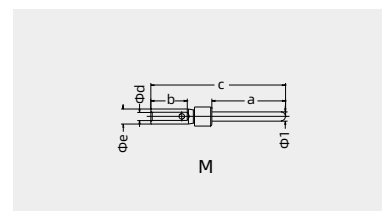

## Tools

Crimping tool



Wire gauge	Designation	Order No.
0.09-0.82mm <sup>2</sup>	TL03	198 001 001 0002

Notes: The tools for crimp terminal may influence the product quality and stability. Please select the tools recognized by our company.



## M17 Circular connector

32V- 7A

## Technical characteristics

Specifications			
Specifications	DIN EN 60 664		
	DIN EN 61 984		
Approvals			
Electrical data		Mechanical data	
Number of contacts	12	Housing material	copper alloy,zinc alloy
Rated current	7A	Housing surface	Nickel-plated
mm <sup>2</sup> / AWG	(0.03-1.0 mm <sup>2</sup> / AWG 32-18)	Contact resistance	≤ 5 mΩ
Rated voltage	32 V	Insulating bodies	PBT
Rated impulse voltage	1.5kV	Contact material	copper alloy
Pollution degree	3	Contact surface	gold plated
Flammability acc. to UL 94	V0 (UL94)	Mechanical working life	>500
Overvoltage categorie	III	Degree of protection	IP67
		Temperature range	-40°C ...+130°C

## Crimp terminal

order crimp contacts separately



## Crimp terminal

order crimp contacts separately



Contacts	Designation	Order No.
12	M17-012-BK21.6-OD2.7	165 012 300 4002

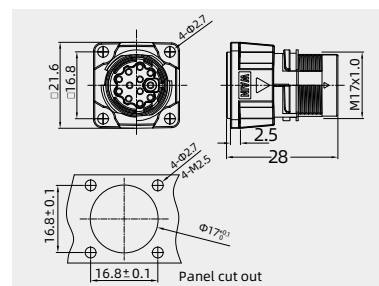

Contacts	Designation	Order No.
12	M17-012-BKR-M20	165 012 320 1500

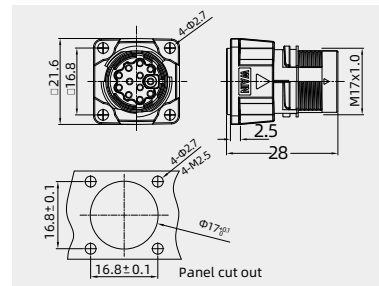

## Crimp contacts

## Crimp contacts



NO.	Wire gauge(mm <sup>2</sup> )	Male	Order No.
①	0.03-0.34	M23-MC9G-0.34	101 031 210 2501
②	0.14-1.0	M23-MC9G-1.0	101 031 210 0801
NO.	Wire gauge(mm <sup>2</sup> )	Female	Order No.
①	0.03-0.34	M23-FC9G-0.34	101 031 220 2501
②	0.14-1.0	M23-FC9G-1.0	101 031 220 0801

NO.	Φa	Φb	Stripping Length
①	1.7	0.9	4mm
②	2.1	1.45	4mm

NO.	Φa	Φb	c	Stripping Length
①	1.7	0.9	14	4mm
②	2.1	1.45	14	4mm

## Tools

## Crimping tool



Wire gauge	Designation	Order No.
0.14-4 mm <sup>2</sup>	TL28-2	198 001 001 0039

Notes: The tools for crimp terminal may influence the product quality and stability. Please select the tools recognized by our company.

Accessories

Stamped contacts

Stamped contacts



coil stock



Note: 10kpcs/volume

Tools

Terminal stamping machir



NO.	Wire gauge(mm <sup>2</sup> )	Male	Order No.
①	0.08-0.2	M23-MC9G-0.2P	101 031 210 0150
②	0.2-0.52	M23-MC9G-0.52P	101 031 210 0550
③	0.75-1.0	M23-MC9G-1.0P	101 031 210 0850
NO.	Wire gauge(mm <sup>2</sup> )	Female	Order No.
①	0.08-0.2	M23-FC9G-0.2P	101 031 220 0150
②	0.2-0.52	M23-FC9G-0.52P	101 031 220 0550
③	0.75-1.0	M23-FC9G-1.0P	101 031 220 0850

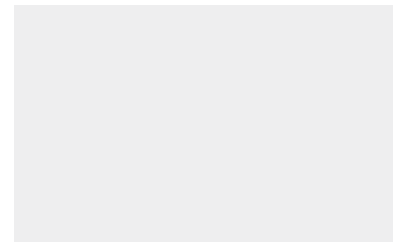
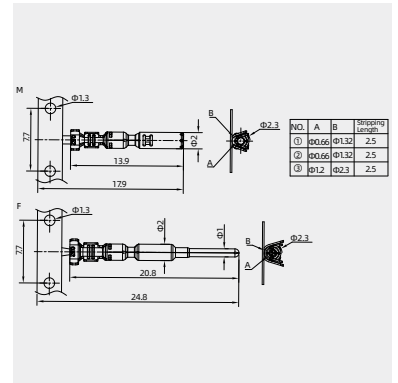

## M17 Circular connector

32V- 7A

## Technical characteristics

Specifications			
Specifications	DIN EN 60 664 DIN EN 61 984		
Approvals			
Electrical data	Mechanical data		
Number of contacts	12	Housing material	copper alloy,zinc alloy
Rated current	7A	Housing surface	Nickel-plated
mm <sup>2</sup> / AWG	(0.03-1.0 mm <sup>2</sup> / AWG 32-18)	Contact resistance	≤ 5 mΩ
Rated voltage	32 V	Insulating bodies	PBT
Rated impulse voltage	1.5kV	Contact material	copper alloy
Pollution degree	3	Contact surface	gold plated
Flammability acc. to UL 94	V0 (UL94)	Mechanical working life	>500
Overvoltage categorie	III	Degree of protection	IP67
		Temperature range	-40°C ...+130°C

 Crimp terminal  
order crimp contacts separately



Contacts	Designation	Order No.
12	M17-012-BK-M17	165 012 300 1500

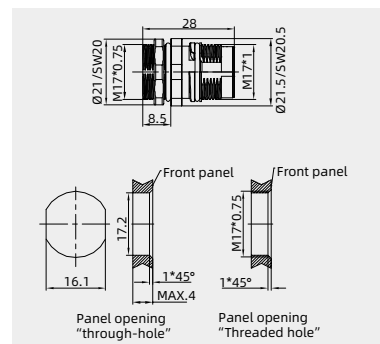
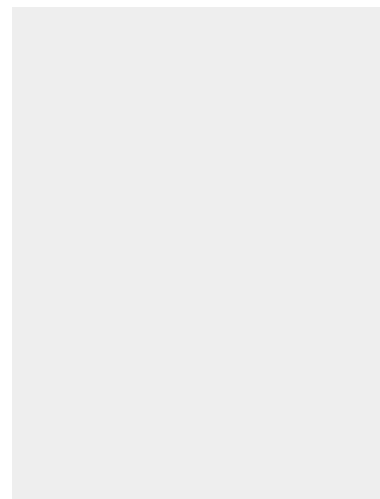

## Crimp contacts

Crimp contacts



NO.	Wire gauge(mm <sup>2</sup> )	Male	Order No.
①	0.03-0.34	M23-MC9G-0.34	101 031 210 2501
②	0.14-1.0	M23-MC9G-1.0	101 031 210 0801

NO.	Wire gauge(mm <sup>2</sup> )	Female	Order No.
①	0.03-0.34	M23-FC9G-0.34	101 031 220 2501
②	0.14-1.0	M23-FC9G-1.0	101 031 220 0801

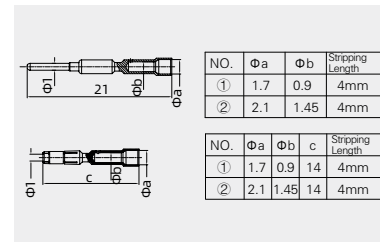

Tools

Crimping tool



Wire gauge	Designation	Order No.
0.14-4 mm <sup>2</sup>	TL28-2	198 001 001 0039

Notes: The tools for crimp terminal may influence the product quality and stability. Please select the tools recognized by our company.

Accessories

Stamped contacts

Stamped contacts



NO.	Wire gauge(mm <sup>2</sup> )	Male	Order No.
①	0.08-0.2	M23-MC9G-0.2P	101 031 210 0150
②	0.2-0.52	M23-MC9G-0.52P	101 031 210 0550
③	0.75-1.0	M23-MC9G-1.0P	101 031 210 0850
NO.	Wire gauge(mm <sup>2</sup> )	Female	Order No.
①	0.08-0.2	M23-FC9G-0.2P	101 031 220 0150
②	0.2-0.52	M23-FC9G-0.52P	101 031 220 0550
③	0.75-1.0	M23-FC9G-1.0P	101 031 220 0850

coil stock



Note: 10kpcs/volume

Tools

Terminal stamping machir



Wire gauge	Designation	Order No.
	M23-XC9G-MJ	903 020 000 0548

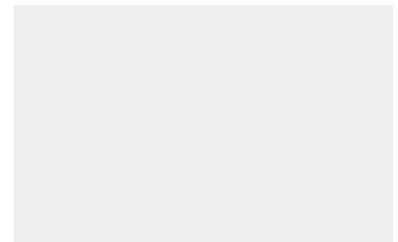
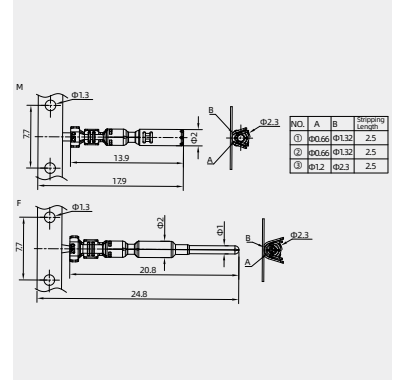

## M17 Circular connector

63V- 3.6A

## Technical characteristics

Specifications			
Specifications	DIN EN 60 664 DIN EN 61 984		
Approvals			
Electrical data	Mechanical data		
Number of contacts	17	Housing material	copper alloy,zinc alloy
Rated current	3.6A	Housing surface	Nickel-plated
mm <sup>2</sup> / AWG	(0.14-0.5 mm <sup>2</sup> / AWG 26-20)	Contact resistance	≤ 5 mΩ
Rated voltage	63 V	Insulating bodies	PBT
Rated impulse voltage	1.5kV	Contact material	copper alloy
Pollution degree	3	Contact surface	gold plated
Flammability acc. to UL 94	V0 (UL94)	Mechanical working life	>500
Overvoltage categorie	III	Degree of protection	IP67
		Temperature range	-40°C ...+130°C

## Male, Crimp terminal

order crimp contacts separately



Contacts	Designation	Order No.
17	M17-MC017-BK21.6-OD2.7	165 017 310 4002

## Female, Crimp terminal

order crimp contacts separately



Contacts	Designation	Order No.
17	M17-FC017-BK21.6-OD2.7	165 017 320 1001

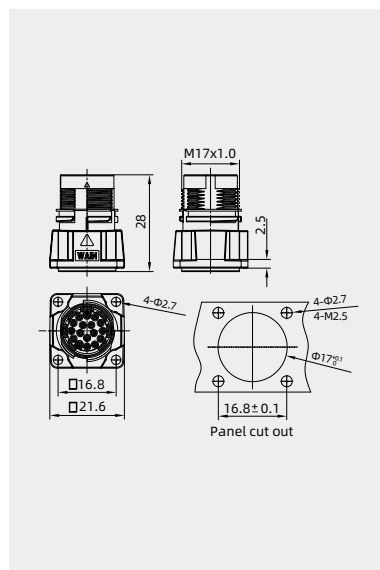
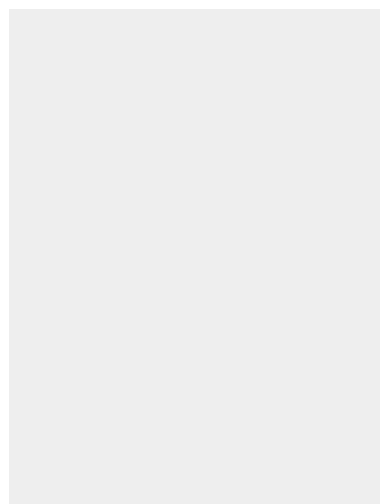

## Crimp contacts

## Crimp contacts 3.6A

3.6A



NO.	Wire gauge(mm <sup>2</sup> )	Male	Order No.
①	0.14-0.5	M17-MC3.6G-0.5	101 039 210 0401

NO.	Wire gauge(mm <sup>2</sup> )	Female	Order No.
①	0.14-0.5	M17-FC3.6G-0.5	101 039 220 0401

## Tools

Crimping tool



Wire gauge	Designation	Order No.
0.09-0.82 mm <sup>2</sup>	TL03	198 001 001 0002

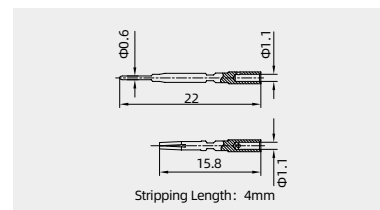

Notes: The tools for crimp terminal may influence the product quality and stability. Please select the tools recognized by our company.

## M17 Circular connector

630/63V- 14/0.6A

## Technical characteristics

Specifications				
Specifications	DIN EN 60 664			
	DIN EN 61 984			
Approvals				
Electrical data		Mechanical data		
Number of contacts	5	3+PE	Housing material	copper alloy,zinc alloy
Rated current	3.6	14A	Housing surface	Nickel-plated
mm <sup>2</sup> / AWG	0.14-0.5/26-20	0.03-1.5/32-16	Contact resistance	≤ 5 mΩ
Rated voltage	63V	630V	Insulating bodies	PBT
Rated impulse voltage	1.5kV	6kV	Contact material	copper alloy
Pollution degree	3	3	Contact surface	gold plated
Flammability acc. to UL 94	V0 (UL94)	V0 (UL94)	Mechanical working life	>500
Overtoltage categorie	III	III	Degree of protection	IP67
			Temperature range	-40°C ...+130°C



## Male, Crimp terminal

order crimp contacts separately



Contacts	Designation	Order No.
17	M17-MC017-BKR-M20	165 017 310 1500

## Female, Crimp terminal

order crimp contacts separately



Contacts	Designation	Order No.
17	M17-FC017-BKR-M20	165 017 320 1500

## Crimp contacts

Crimp contacts 3.6A

3.6A(signal)



NO.	Wire gauge(mm <sup>2</sup> )	Male	Order No.
①	0.14-0.5	M17-MC3.6G-0.5	101 039 210 0401

NO.	Wire gauge(mm <sup>2</sup> )	Female	Order No.
①	0.14-0.5	M17-FC3.6G-0.5	101 039 220 0401

## Crimp contacts

power



NO.	Wire gauge(mm <sup>2</sup> )	Male	Order No.
①	0.03-0.34	M23-MC9G-0.34	101 031 210 2501
②	0.14-1.0	M23-MC9G-1.0	101 031 210 0801
③	0.5-1.5	M23-MC9G-1.5	101 031 210 0901

NO.	Wire gauge(mm <sup>2</sup> )	Female	Order No.
①	0.03-0.34	M23-FC9G-0.34	101 031 220 2501
②	0.14-1.0	M23-FC9G-1.0	101 031 220 0801
③	0.5-1.5	M23-FC9G-1.5	101 031 220 0901

## Tools

Crimping tool



Wire gauge	Designation	Order No.
0.09-0.82 mm <sup>2</sup>	TL03	198 001 001 0002

## Tools

Crimping tool



Wire gauge	Designation	Order No.
0.14-4 mm <sup>2</sup>	TL28-2	198 001 001 0039

Notes: The tools for crimp terminal may influence the product quality and stability. Please select the tools recognized by our company.  
21S-07.1 WAIN ELECTRICAL

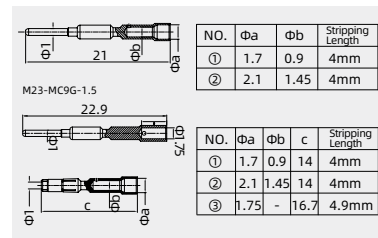
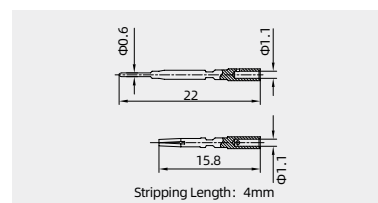
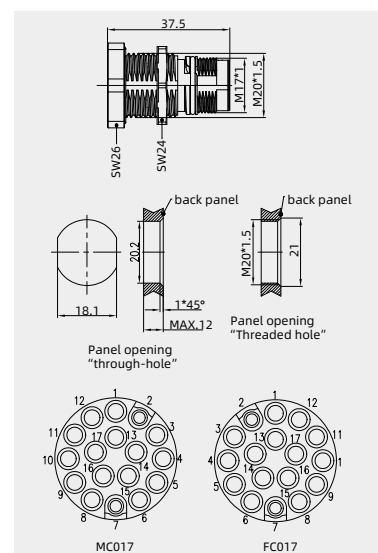
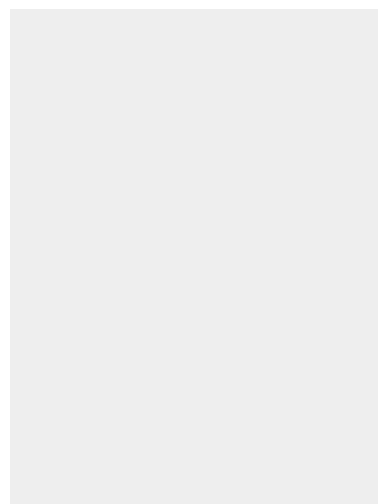

Accessories

Stamped contacts

Stamped contacts



coil stock



Note: 10kpcs/volume

NO.	Wire gauge(mm <sup>2</sup> )	Male	Order No.
①	0.08-0.2	M23-MC9G-0.2P	101 031 210 0150
②	0.2-0.52	M23-MC9G-0.52P	101 031 210 0550
③	0.75-1.0	M23-MC9G-1.0P	101 031 210 0850
NO.	Wire gauge(mm <sup>2</sup> )	Female	Order No.
①	0.08-0.2	M23-FC9G-0.2P	101 031 220 0150
②	0.2-0.52	M23-FC9G-0.52P	101 031 220 0550
③	0.75-1.0	M23-FC9G-1.0P	101 031 220 0850

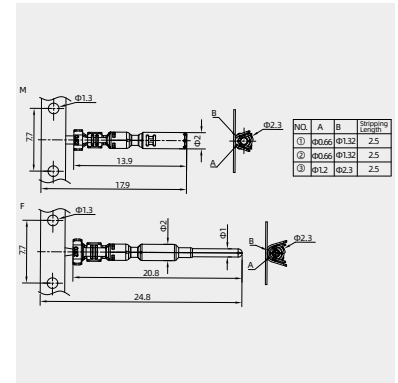

Tools

Terminal stamping machir



Wire gauge	Designation	Order No.
	M23-XC9G-MJ	903 020 000 0548

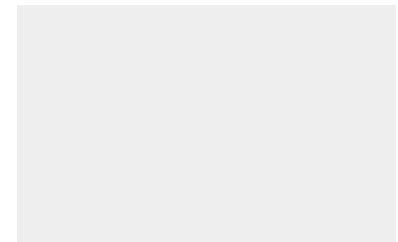

## M17 Circular connector

630/63V- 14/0.6A

## Technical characteristics

Specifications				
Specifications	DIN EN 60 664 DIN EN 61 984			
Approvals				
Electrical data	Mechanical data			
Number of contacts	5	3+PE	Housing material	copper alloy,zinc alloy
Rated current	3.6	14A	Housing surface	Nickel-plated
mm <sup>2</sup> / AWG	0.14-0.5/26-20	0.03-1.5/32-16	Contact resistance	≤ 5 mΩ
Rated voltage	63V	630V	Insulating bodies	PBT
Rated impulse voltage	1.5kV	6kV	Contact material	copper alloy
Pollution degree	3	3	Contact surface	gold plated
Flammability acc. to UL 94	V0 (UL94)	V0 (UL94)	Mechanical working life	>500
Overvoltage categorie	III	III	Degree of protection	IP67
			Temperature range	-40°C ...+130°C



## Male, Crimp terminal

order crimp contacts separately



Contacts	Designation	Order No.
17	M17-MC017-BK-M17	165 017 310 1502

## Female, Crimp terminal

order crimp contacts separately



Contacts	Designation	Order No.
17	M17-FC017-BK-M17	165 017 320 1502

## Crimp contacts

Crimp contacts 3.6A

3.6A(signal)



NO.	Wire gauge(mm <sup>2</sup> )	Male	Order No.
①	0.14-0.5	M17-MC3.6G-0.5	101 039 210 0401
NO.	Wire gauge(mm <sup>2</sup> )	Female	Order No.
①	0.14-0.5	M17-FC3.6G-0.5	101 039 220 0401

## Crimp contacts

power



NO.	Wire gauge(mm <sup>2</sup> )	Male	Order No.
①	0.03-0.34	M23-MC9G-0.34	101 031 210 2501
②	0.14-1.0	M23-MC9G-1.0	101 031 210 0801
③	0.5-1.5	M23-MC9G-1.5	101 031 210 0901
NO.	Wire gauge(mm <sup>2</sup> )	Female	Order No.
①	0.03-0.34	M23-FC9G-0.34	101 031 220 2501
②	0.14-1.0	M23-FC9G-1.0	101 031 220 0801
③	0.5-1.5	M23-FC9G-1.5	101 031 220 0901

## Tools

Crimping tool



Wire gauge	Designation	Order No.
0.09-0.82 mm <sup>2</sup>	TL03	198 001 001 0002

## Tools

Crimping tool



Wire gauge	Designation	Order No.
0.14-4 mm <sup>2</sup>	TL28-2	198 001 001 0039

Notes: The tools for crimp terminal may influence the product quality and stability. Please select the tools recognized by our company.

21S-07.2 WAIN ELECTRICAL

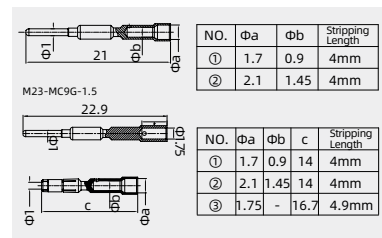
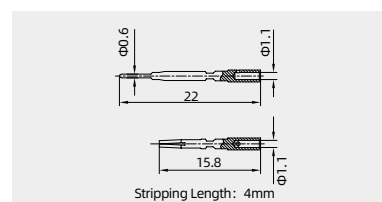
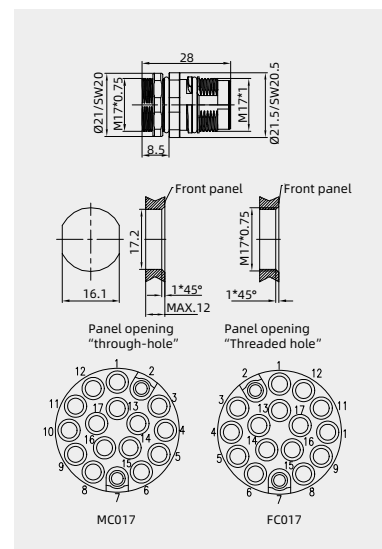
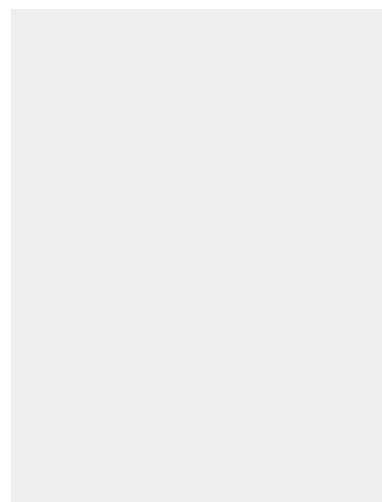



Accessories

Stamped contacts

Stamped contacts



coil stock



Note: 10kpcs/volume

NO.	Wire gauge(mm <sup>2</sup> )	Male	Order No.
①	0.08-0.2	M23-MC9G-0.2P	101 031 210 0150
②	0.2-0.52	M23-MC9G-0.52P	101 031 210 0550
③	0.75-1.0	M23-MC9G-1.0P	101 031 210 0850

NO.	Wire gauge(mm <sup>2</sup> )	Female	Order No.
①	0.08-0.2	M23-FC9G-0.2P	101 031 220 0150
②	0.2-0.52	M23-FC9G-0.52P	101 031 220 0550
③	0.75-1.0	M23-FC9G-1.0P	101 031 220 0850

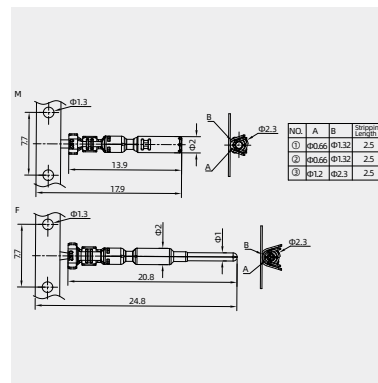

Tools

Terminal stamping machir



Wire gauge	Designation	Order No.
	M23-XC9G-MJ	903 020 000 0548

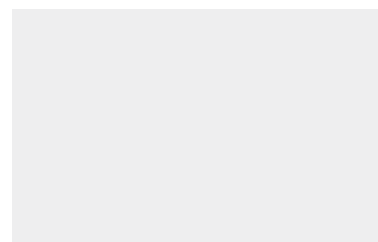

## M17 Circular connector

630V- 20A

## Technical characteristics

Specifications			
Specifications	DIN EN 60 664 DIN EN 61 984		
Approvals			
Electrical data	Mechanical data		
Number of contacts	4(3+PE)	Housing material	copper alloy,zinc alloy
Rated current	20A	Housing surface	Nickel-plated
mm <sup>2</sup> / AWG	(0.35-2.5 mm <sup>2</sup> / AWG 22-14)	Contact resistance	≤ 5 mΩ
Rated voltage	630V	Insulating bodies	PBT
Rated impulse voltage	6kV	Contact material	copper alloy
Pollution degree	3	Contact surface	gold plated
Flammability acc. to UL 94	V0 (UL94)	Mechanical working life	>500
Overvoltage categorie	III	Degree of protection	IP67
		Temperature range	-40°C ...+130°C

## Male, Crimp terminal

order crimp contacts separately



Contacts	Designation	Order No.
4(3+PE)	M17-MC04-BKP21.6-SE-OD2.7	165 004 310 1003
	M17-MC04-BKP26-SE-OD2.7	165 004 610 2500
	M17-MC04-BKP28-SE-OD3.2	165 004 610 2503

## Female, Crimp terminal

order crimp contacts separately



Contacts	Designation	Order No.
4(3+PE)	M17-FC04-BKP21.6-SE-OD2.7	165 004 620 2500
	M17-FC04-BKP26-SE-OD2.7	165 004 620 2501
	M17-FC04-BKP28-SE-OD3.2	165 004 620 2502

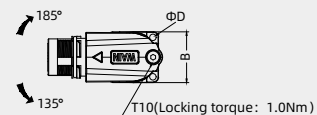
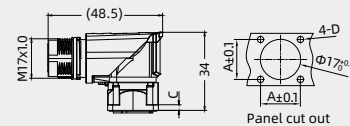

Designation	A	B	C	D
BKP21.6	16.8	21.6	2.5	Φ2.7/M2.5
BKP26	19.8	26.0	2.5	Φ2.7/M2.5
BKP28	22.6	28.0	4.5	Φ3.2/M3

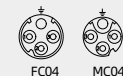

## Crimp contacts

## Crimp contacts 20A

Wire gauge(mm <sup>2</sup> )	Male	Order No.
0.35-2.5	M17-MC20G-2.5	101 020 210 1002

M17



Wire gauge(mm <sup>2</sup> )	Female	Order No.
0.35-2.5	M17-FC20G-2.5	101 020 220 1002

## Tools

## Crimping tool



Wire gauge	Designation	Order No.
0.14-4 mm <sup>2</sup>	TL28-2	198 001 001 0039

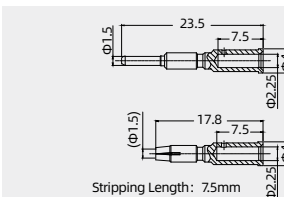

Notes: The tools for crimp terminal may influence the product quality and stability. Please select the tools recognized by our company.

## M17 Circular connector

630V- 14A

## Technical characteristics

Specifications			
Specifications	DIN EN 60 664 DIN EN 61 984		
Approvals			
Electrical data	Mechanical data		
Number of contacts	7(6+PE)	Housing material	copper alloy,zinc alloy
Rated current	14A	Housing surface	Nickel-plated
mm <sup>2</sup> / AWG	(0.03-1.5 mm <sup>2</sup> / AWG 32-16)	Contact resistance	≤ 5 mΩ
Rated voltage	630 V	Insulating bodies	PBT
Rated impulse voltage	6kV	Contact material	copper alloy
Pollution degree	3	Contact surface	gold plated
Flammability acc. to UL 94	V0 (UL94)	Mechanical working life	>500
Overvoltage categorie	III	Degree of protection	IP67
		Temperature range	-40°C ...+130°C

## Crimp terminal

order crimp contacts separately



Contacts	Designation	Order No.
7	M17-007-BKP21.6-SE-OD2.7	165 007 300 4001
	M17-007-BKP26-SE-OD2.7	165 007 300 4007
	M17-007-BKP28-SE-OD3.2	165 007 300 4011
	M17-007R-BKP21.6-SE-OD2.7	165 007 300 4006
	M17-007R-BKP26-SE-OD2.7	165 007 300 4008
	M17-007R-BKP28-SE-OD3.2	165 007 300 4012
	M17-007/B-BKP21.6-SE-OD2.7	165 007 300 4004
	M17-007/B-BKP26-SE-OD2.7	165 007 300 4009
	M17-007/B-BKP28-SE-OD3.2	165 007 300 4013
	M17-007R/B-BKP21.6-SE-OD2.7	165 007 300 4005
	M17-007R/B-BKP26-SE-OD2.7	165 007 300 4010
	M17-007R/B-BKP28-SE-OD3.2	165 007 300 4014

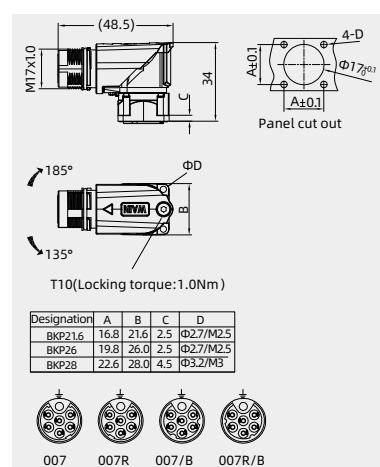
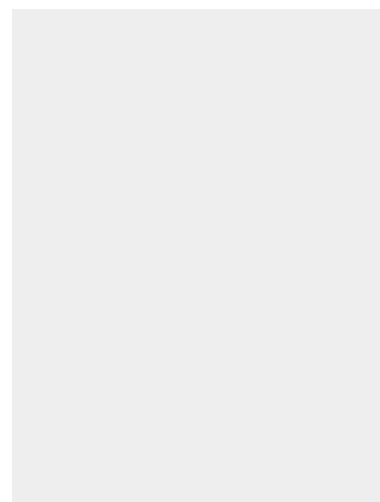

## Crimp contacts

Crimp contacts



NO.	Wire gauge(mm <sup>2</sup> )	Male	Order No.
①	0.03-0.34	M23-MC9G-0.34	101 031 210 2501
②	0.14-1.0	M23-MC9G-1.0	101 031 210 0801
③	0.5-1.5	M23-MC9G-1.5	101 031 210 0901
NO.	Wire gauge(mm <sup>2</sup> )	Female	Order No.
①	0.03-0.34	M23-FC9G-0.34	101 031 220 2501
②	0.14-1.0	M23-FC9G-1.0	101 031 220 0801
③	0.5-1.5	M23-FC9G-1.5	101 031 220 0901

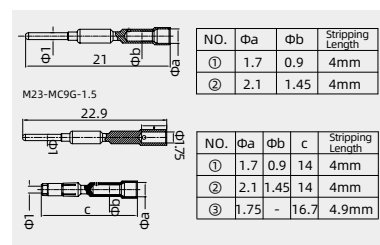

## Tools

Crimping tool



Wire gauge	Designation	Order No.
0.14-4 mm <sup>2</sup>	TL28-2	198 001 001 0039

Notes: The tools for crimp terminal may influence the product quality and stability. Please select the tools recognized by our company.

Accessories

Stamped contacts

Stamped contacts



coil stock



Note: 10kpcs/volume

Tools

Terminal stamping machir



NO.	Wire gauge(mm <sup>2</sup> )	Male	Order No.
①	0.08-0.2	M23-MC9G-0.2P	101 031 210 0150
②	0.2-0.52	M23-MC9G-0.52P	101 031 210 0550
③	0.75-1.0	M23-MC9G-1.0P	101 031 210 0850
NO.	Wire gauge(mm <sup>2</sup> )	Female	Order No.
①	0.08-0.2	M23-FC9G-0.2P	101 031 220 0150
②	0.2-0.52	M23-FC9G-0.52P	101 031 220 0550
③	0.75-1.0	M23-FC9G-1.0P	101 031 220 0850

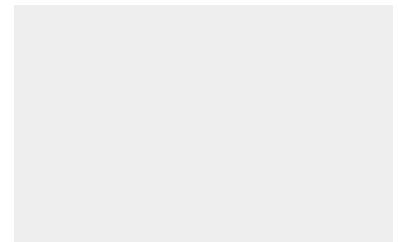
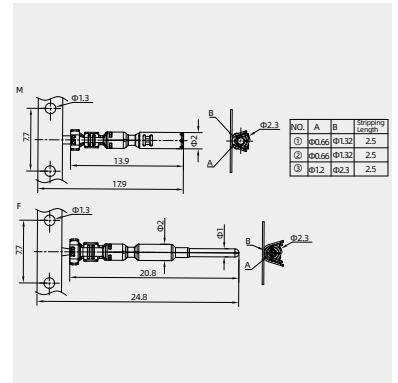

## M17 Circular connector

630/63V - 14/0.6A

## Technical characteristics

Specifications			
Specifications	DIN EN 60 664		
	DIN EN 61 984		
Approvals			
Electrical data		Mechanical data	
Number of contacts	5	3+PE	Housing material
Rated current	3.6	14A	Housing surface
mm <sup>2</sup> / AWG	0.14-0.5/26-20	0.03-1.5/32-16	Contact resistance
Rated voltage	63V	630V	Insulating bodies
Rated impulse voltage	1.5kV	6kV	Contact material
Pollution degree	3	3	Contact surface
Flammability acc. to UL 94	V0 (UL94)	V0 (UL94)	Mechanical working life
Overvoltage categorie	III	III	Degree of protection
			Temperature range

## Male, Crimp terminal

order crimp contacts separately



Contacts	Designation	Order No.
9(5+4(3+PE))	M17-MC04/5-BKP21.6-SE-OD2.7	165 009 610 2500
	M17-MC04/5-BKP26-SE-OD2.7	165 009 510 2500
	M17-MC04/5-BKP28-SE-OD3.2	165 009 610 2501

## Female, Crimp terminal

order crimp contacts separately



Contacts	Designation	Order No.
9(5+4(3+PE))	M17-FC04/5-BKP21.6-SE-OD2.7	165 009 620 2500
	M17-FC04/5-BKP26-SE-OD2.7	165 009 620 2501
	M17-FC04/5-BKP28-SE-OD3.2	165 009 620 2502

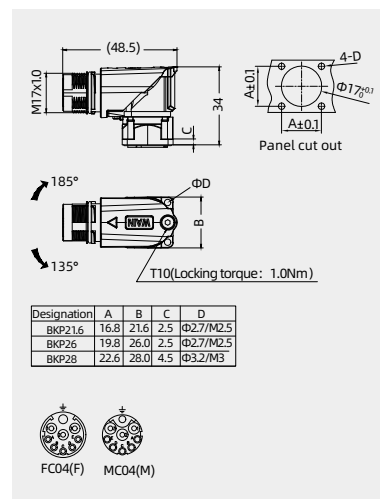
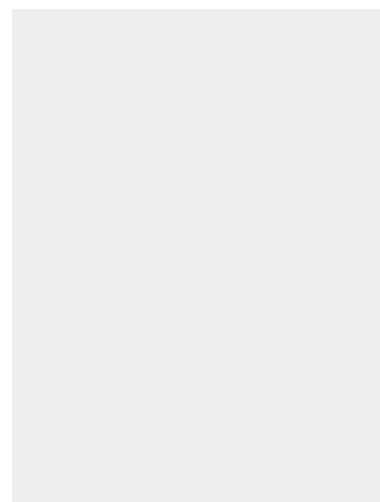

## Crimp contacts

## Crimp contacts 3.6A

3.6A(signal)



NO.	Wire gauge(mm <sup>2</sup> )	Male	Order No.
①	0.14-0.5	M17-MC3.6G-0.5	101 039 210 0401

NO.	Wire gauge(mm <sup>2</sup> )	Female	Order No.
①	0.14-0.5	M17-FC3.6G-0.5	101 039 220 0401

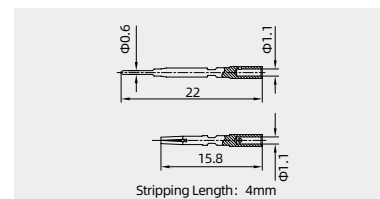

## Crimp contacts

power



NO.	Wire gauge(mm <sup>2</sup> )	Male	Order No.
①	0.03-0.34	M23-MC9G-0.34	101 031 210 2501
②	0.14-1.0	M23-MC9G-1.0	101 031 210 0801
③	0.5-1.5	M23-MC9G-1.5	101 031 210 0901

NO.	Wire gauge(mm <sup>2</sup> )	Female	Order No.
①	0.03-0.34	M23-FC9G-0.34	101 031 220 2501
②	0.14-1.0	M23-FC9G-1.0	101 031 220 0801
③	0.5-1.5	M23-FC9G-1.5	101 031 220 0901

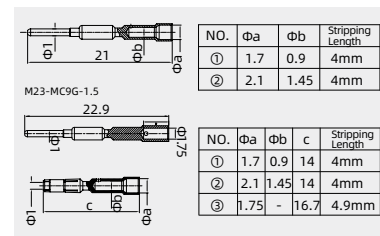

## Tools

Crimping tool



Wire gauge	Designation	Order No.
0.09-0.82 mm <sup>2</sup>	TL03	198 001 001 0002

## Tools

Crimping tool



Wire gauge	Designation	Order No.
0.14-4 mm <sup>2</sup>	TL28-2	198 001 001 0039

Notes: The tools for crimp terminal may influence the product quality and stability. Please select the tools recognized by our company.

Accessories

Stamped contacts

Stamped contacts



NO.	Wire gauge(mm <sup>2</sup> )	Male	Order No.
①	0.08-0.2	M23-MC9G-0.2P	101 031 210 0150
②	0.2-0.52	M23-MC9G-0.52P	101 031 210 0550
③	0.75-1.0	M23-MC9G-1.0P	101 031 210 0850
NO.	Wire gauge(mm <sup>2</sup> )	Female	Order No.
①	0.08-0.2	M23-FC9G-0.2P	101 031 220 0150
②	0.2-0.52	M23-FC9G-0.52P	101 031 220 0550
③	0.75-1.0	M23-FC9G-1.0P	101 031 220 0850

coil stock



Note: 10kpcs/volume

Tools

Terminal stamping machir



Wire gauge	Designation	Order No.
	M23-XC9G-MJ	903 020 000 0548

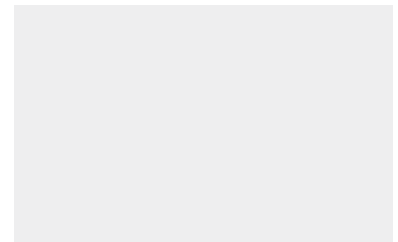
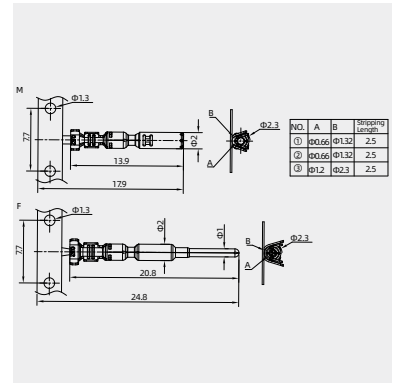

## M17 Circular connector

48V- 7.5A

## Technical characteristics

Specifications			
Specifications	DIN EN 60 664 DIN EN 61 984		
Approvals			
Electrical data	Mechanical data		
Number of contacts	10	Housing material	copper alloy,zinc alloy
Rated current	7.5A	Housing surface	Nickel-plated
mm <sup>2</sup> / AWG	(0.09-0.82mm <sup>2</sup> / AWG 28-18)	Contact resistance	≤ 10 mΩ
Rated voltage	48 V	Insulating bodies	PBT
Rated impulse voltage	1.5kV	Contact material	copper alloy
Pollution degree	3	Contact surface	gold plated
Flammability acc. to UL 94	V0 (UL94)	Mechanical working life	>500
Overvoltage categorie	III	Degree of protection	IP67
		Temperature range	-40°C ...+130°C

## Crimp terminal

order crimp contacts separately



Contacts	Designation	Order No.
10	M17-MC010-BKP21.6-SE-OD2.7	165 010 610 1500
	M17-MC010-BKP26-SE-OD2.7	165 010 610 1501
	M17-MC010-BKP28-SE-OD3.2	165 010 610 1502

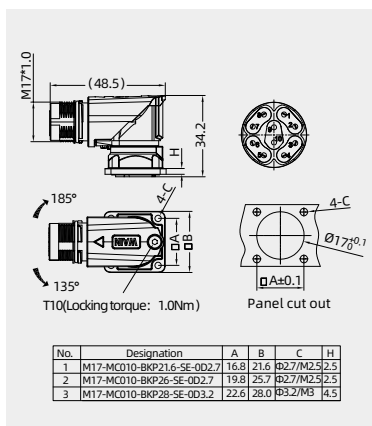

## Accessories

## Crimp contacts 5A

gold plated



Wire gauge(mm <sup>2</sup> )	Male	Order No.
0.09-0.25	CSGM-0.25	101 014 210 0101
0.13-0.33	CSGM-0.33	101 014 210 0201
0.33-0.52	CSGM-0.52	101 014 210 0501
0.33-0.82	CSGM-0.82	101 014 210 0701

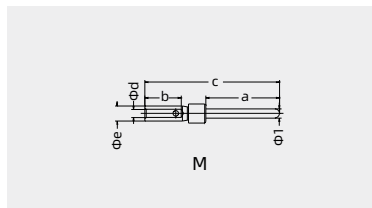

## Tools

Crimping tool



Wire gauge	Designation	Order No.
0.09-0.82mm <sup>2</sup>	TL03	198 001 001 0002

Notes: The tools for crimp terminal may influence the product quality and stability. Please select the tools recognized by our company.

## M17 Circular connector

32V- 7A

## Technical characteristics

Specifications		Mechanical data	
Specifications	DIN EN 60 664 DIN EN 61 984	Housing material	copper alloy,zinc alloy
Approvals		Housing surface	Nickel-plated
Electrical data		Contact resistance	≤ 5 mΩ
Number of contacts	12	Insulating bodies	PBT
Rated current	7A	Contact material	copper alloy
mm <sup>2</sup> / AWG	(0.03-1.0 mm <sup>2</sup> / AWG 32-18)	Contact surface	gold plated
Rated voltage	32 V	Mechanical working life	>500
Rated impulse voltage	1.5kV	Degree of protection	IP67
Pollution degree	3	Temperature range	-40°C ...+130°C
Flammability acc. to UL 94	V0 (UL94)		
Overvoltage categorie	III		

## Crimp terminal

order crimp contacts separately

Contacts	Designation	Order No.
12	M17-012-BKP21.6-SE-OD2.7	165 012 300 4001
	M17-012-BKP26-SE-OD2.7	165 012 300 2001
	M17-012-BKP28-SE-OD3.2	165 012 300 2002

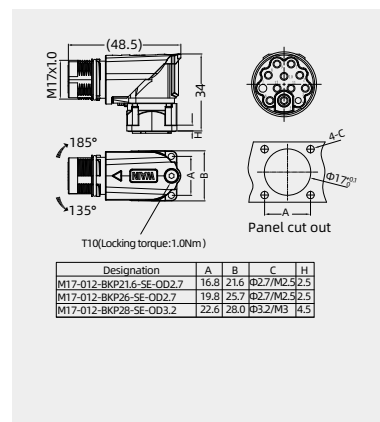
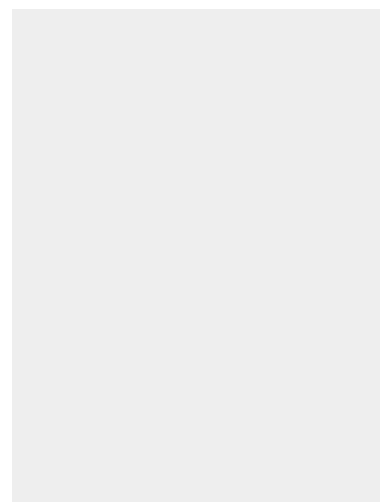

## Crimp contacts

## Crimp contacts



NO.	Wire gauge(mm <sup>2</sup> )	Male	Order No.
①	0.03-0.34	M23-MC9G-0.34	101 031 210 2501
②	0.14-1.0	M23-MC9G-1.0	101 031 210 0801
NO.	Wire gauge(mm <sup>2</sup> )	Female	Order No.
①	0.03-0.34	M23-FC9G-0.34	101 031 220 2501
②	0.14-1.0	M23-FC9G-1.0	101 031 220 0801

## Tools

## Crimping tool



Wire gauge	Designation	Order No.
0.14-4 mm <sup>2</sup>	TL28-2	198 001 001 0039

NO.	Φa	Φb	Stripping Length
①	1.7	0.9	4mm
②	2.1	1.45	4mm

NO.	Φa	Φb	c	Stripping Length
①	1.7	0.9	14	4mm
②	2.1	1.45	14	4mm

Notes: The tools for crimp terminal may influence the product quality and stability. Please select the tools recognized by our company.



Accessories

Stamped contacts

Stamped contacts



coil stock



Note: 10kpcs/volume

NO.	Wire gauge(mm <sup>2</sup> )	Male	Order No.
①	0.08-0.2	M23-MC9G-0.2P	101 031 210 0150
②	0.2-0.52	M23-MC9G-0.52P	101 031 210 0550
③	0.75-1.0	M23-MC9G-1.0P	101 031 210 0850
NO.	Wire gauge(mm <sup>2</sup> )	Female	Order No.
①	0.08-0.2	M23-FC9G-0.2P	101 031 220 0150
②	0.2-0.52	M23-FC9G-0.52P	101 031 220 0550
③	0.75-1.0	M23-FC9G-1.0P	101 031 220 0850

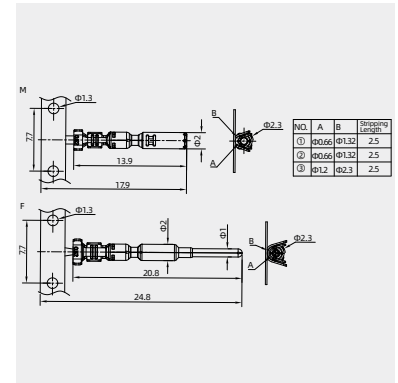

Tools

Terminal stamping machir



Wire gauge	Designation	Order No.
	M23-XC9G-MJ	903 020 000 0548

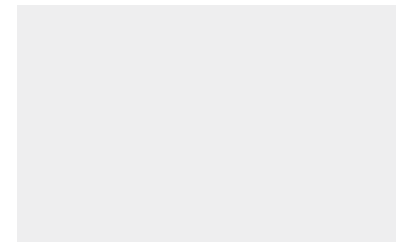

## M17 Circular connector

63V- 3.6A

## Technical characteristics

Specifications			
Specifications	DIN EN 60 664 DIN EN 61 984		
Approvals			
Electrical data	Mechanical data		
Number of contacts	17	Housing material	copper alloy,zinc alloy
Rated current	3.6A	Housing surface	Nickel-plated
mm <sup>2</sup> / AWG	(0.14-0.5 mm <sup>2</sup> / AWG 26-20)	Contact resistance	≤ 5 mΩ
Rated voltage	63 V	Insulating bodies	PBT
Rated impulse voltage	1.5kV	Contact material	copper alloy
Pollution degree	3	Contact surface	gold plated
Flammability acc. to UL 94	V0 (UL94)	Mechanical working life	>500
Overvoltage categorie	III	Degree of protection	IP67
		Temperature range	-40°C ...+130°C

## Male, Crimp terminal

order crimp contacts separately



Contacts	Designation	Order No.
17	M17-MC017-BKP21.6-SE-OD2.7	165 017 310 4001
	M17-MC017-BKP26-SE-OD2.7	165 017 310 1001
	M17-MC017-BKP28-SE-OD3.2	165 017 310 1002

## Female, Crimp terminal

order crimp contacts separately



Contacts	Designation	Order No.
17	M17-FC017-BKP21.6-SE-OD2.7	165 017 320 1002
	M17-FC017-BKP26-SE-OD2.7	165 017 320 1003
	M17-FC017-BKP28-SE-OD3.2	165 017 320 1004

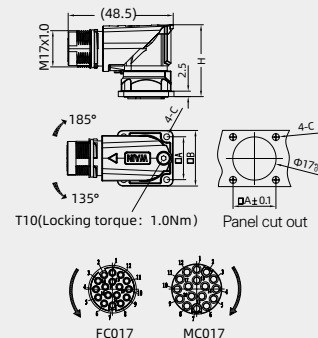

Designation	A	B	C	H
M17-MC017-BKP21.6-SE-OD2.7	16.8	21.6	Ø27/M2.5	2.5
M17-MC017-BKP26-SE-OD2.7	16.8	21.6	Ø27/M2.5	2.5
M17-MC017-BKP28-SE-OD3.2	19.8	25.7	Ø27/M2.5	2.5
M17-FC017-BKP21.6-SE-OD2.7	19.8	25.7	Ø27/M2.5	2.5
M17-FC017-BKP26-SE-OD2.7	22.6	28.0	Ø3.2/MB	4.5
M17-FC017-BKP28-SE-OD3.2	22.6	28.0	Ø3.2/MB	4.5

## Crimp contacts

## Crimp contacts 3.6A

3.6A(signal)



NO.	Wire gauge(mm <sup>2</sup> )	Male	Order No.
①	0.14-0.5	M17-MC3.6G-0.5	101 039 210 0401
NO.	Wire gauge(mm <sup>2</sup> )	Female	Order No.
①	0.14-0.5	M17-FC3.6G-0.5	101 039 220 0401

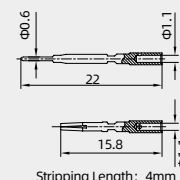

## Tools

Crimping tool



Wire gauge	Designation	Order No.
0.09-0.82 mm <sup>2</sup>	TL03	198 001 001 0002

Notes: The tools for crimp terminal may influence the product quality and stability. Please select the tools recognized by our company.

Accessories

Protection covers IP65

M17 core extractor



Description	Designation	Order No.
	M17-TL01	198 001 000 0039

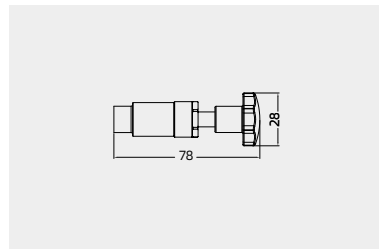

M17 Protection cover



Description	Designation	Order No.
	M17-CV-F	165 000 000 9500

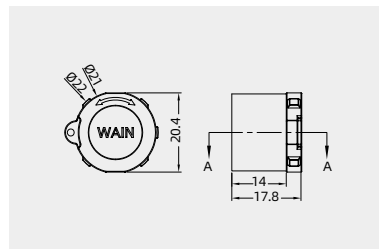

## HR23 SERIES

M23 Circular connector-Signal Connection



## HR23 Circular connector

## · Features

- Size R 23
- Outer diameter 26 mm
- High contact density
- Very robust hoods and housings
- Corrosion resistant
- Excellent EMC properties  
(with continuous shielding)
- Quick and easy assembly
- Vibration resistant screw locking system
- Up to 19 contacts, 25 V~ / 60 V-
- Ideal for applications such as measurement and automatic control

## · Description

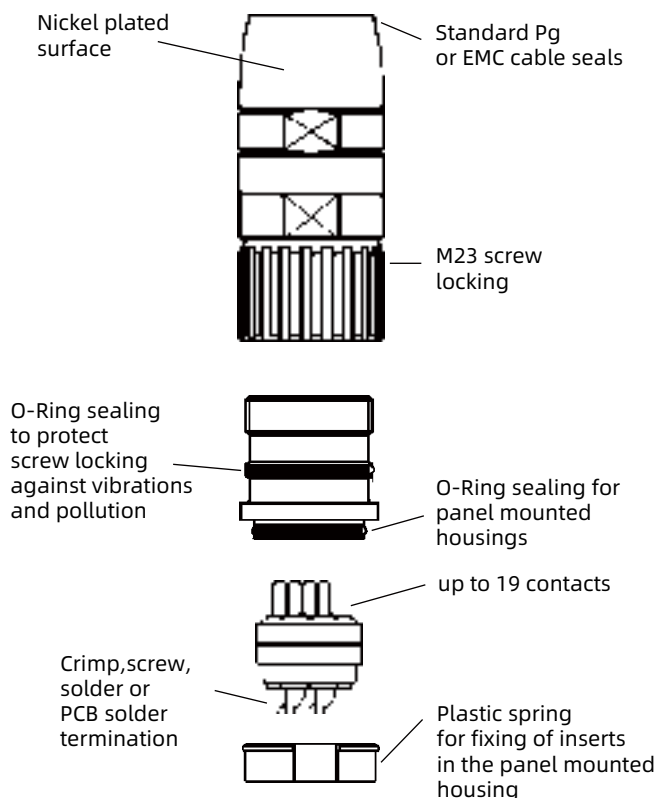

## HR23-006 Circular inserts

25V~/60V- 15A

## Inserts

Hoods/Housings: size HR23 ,detail please find the page22-09~22-11.

## Technical characteristics

Specifications	
Specifications	DIN EN 60 664 DIN EN 61 984
Approvals	
Inserts	Contacts
Number of contacts	6
Electrical data acc. to EN 61 984	Material
Rated current	copper alloy
-power contact	Surface
Rated voltage	gold plated
Pollution degree	Contact resistance
Rated impulse voltage	$\leq 5 \text{ m}\Omega$
Insulation resistance	Screw termination
Material	-power contact
Temperature range	$0.14\text{-}1.0 \text{ mm}^2 / \text{AWG } 26\text{-}16$
Flammability acc. to UL 94	Solder termination
V0	-power contact
	$0.14\text{-}2.5 \text{ mm}^2 / \text{AWG } 26\text{-}14$
	PCB solder termination
	-power contact
	$\Phi 1.5 \text{ mm}$
	-reference to
	3.5 mm
	bulkhead mounted housing



## Screw termination



Inserts	Designation	Order No.
Male	HR23-006-M	181 006 011 0001
Female	HR23-006-F	181 006 021 0001
Reverse coding		
Male	HR23-006R-M	181 006 011 0101
Female	HR23-006R-F	181 006 021 0101

## Solder terminal



Inserts	Designation	Order No.
Male	HR23-006-MST	181 006 013 0001
Female	HR23-006-FST	181 006 023 0001
Reverse coding		
Male	HR23-006R-MST	181 006 013 0101
Female	HR23-006R-FST	181 006 023 0101

## PCB solder termination



Inserts	Designation	Order No.
Male	HR23-006-MTHT <sup>2)</sup>	181 006 014 0001
Female	HR23-006-FTHT <sup>2)</sup>	181 006 024 0001
Reverse coding		
Male	HR23-006R-MTHT <sup>2)</sup>	181 006 014 0101
Female	HR23-006R-FTHT <sup>2)</sup>	181 006 024 0101

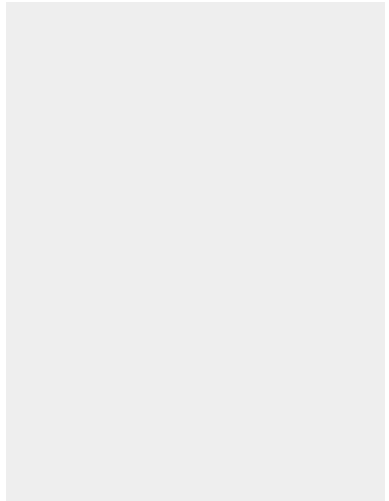

Contact arrangement: mating side

Reverse coding

PCB layout

2) Suitable only for bulkhead mounted housings: HR23-BK-D2.7, HR23-BK/R-OD2.7 and HR23-BK/R-OM2.5

## HR23-007 Circular inserts

25V~/60V- 15A

## Inserts

Hoods/Housings: size HR23 ,detail please find the page22-09~22-11.

## Technical characteristics

## Specifications

Specifications	DIN EN 60 664
	DIN EN 61 984

## Approvals

Inserts		Contacts	
Number of contacts	7	Material	copper alloy
Electrical data acc. to EN 61 984		Surface	gold plated
Rated current		Contact resistance	≤ 5 mΩ
-power contact	15A	Screw termination	
Rated voltage	25 V~/60 V-	-power contact	0.14-1.0 mm <sup>2</sup> / AWG 26-16
Pollution degree	3	Solder terminal	
Rated impulse voltage	1.5 kV	-power contact	0.14-2.5 mm <sup>2</sup> / AWG 26-14
Insulation resistance	≥ 10 <sup>12</sup> Ω		
Material	PBT		
Temperature range	-40°C ...+130°C		
Flammability acc. to UL 94	V0		

## Screw termination



Inserts	Designation	Order No.
Male	HR23-007-M	181 007 011 0001
Female	HR23-007-F	181 007 021 0001
Reverse coding		
Male	HR23-007R-M	181 007 011 0101
Female	HR23-007R-F	181 007 021 0101

## Solder terminal



Inserts	Designation	Order No.
Male	HR23-007-MST	181 007 013 0001
Female	HR23-007-FST	181 007 023 0001
Reverse coding		
Male	HR23-007R-MST	181 007 013 0101
Female	HR23-007R-FST	181 007 023 0101

## Contact arrangement: mating side

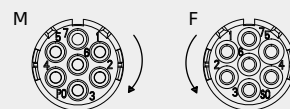

## Reverse coding

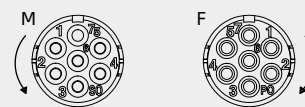

## HR23-009 Circular inserts

25V~/60V- 15/7A

## Inserts

Hoods/Housings: size HR23 ,detail please find the page22-09~22-11.

## Technical characteristics

Specifications	
Specifications	DIN EN 60 664 DIN EN 61 984
Approvals	
Inserts	Contacts
Number of contacts	9
Electrical data acc. to EN 61 984	Material copper alloy
Rated current	Surface gold plated
-power contact	Contact resistance $\leq 5 \text{ m}\Omega$
-signal contact	Screw termination
Rated voltage	-power contact 0.14-1.0 mm <sup>2</sup> / AWG 26-16
Pollution degree	-signal contact 0.14-0.75 mm <sup>2</sup> / AWG 26-18
Rated impulse voltage	Solder terminal
Insulation resistance	-power contact 0.14-2.5 mm <sup>2</sup> / AWG 26-14
Material	-signal contact 0.14-1.0 mm <sup>2</sup> / AWG 26-16
Temperature range	
Flammability acc. to UL 94	V0

## Screw termination



Inserts	Designation	Order No.
Male	HR23-009-M	181 009 011 0001
Female	HR23-009-F	181 009 021 0001

## Solder terminal



Inserts	Designation	Order No.
Male	HR23-009-MST	181 009 013 0001
Female	HR23-009-FST	181 009 023 0001
	Reverse coding	
Male	HR23-009R-MST	181 009 013 0101
Female	HR23-009R-FST	181 009 023 0101

## Contact arrangement: mating side

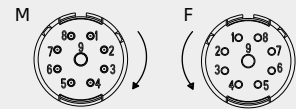

## Reverse coding

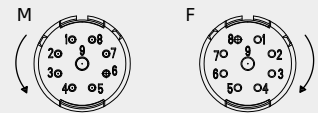



## HR23-012 Circular inserts

25V~/60V- 7A

## Inserts

Hoods/Housings: size HR23 ,detail please find the page22-09~22-11.

## Technical characteristics

Specifications	
Specifications	DIN EN 60 664 DIN EN 61 984
Approvals	
Inserts	Contacts
Number of contacts	12
Electrical data acc. to EN 61 984	Material copper alloy
Rated current	Surface gold plated
-signal contact	Contact resistance $\leq 5 \text{ m}\Omega$
Rated voltage	Crimp termination
Pollution degree	- D-Sub contact 0.09-0.82 mm <sup>2</sup> / AWG 28-18
Rated impulse voltage	Solder termination
Insulation resistance	- signal contact 0.14-1.0 mm <sup>2</sup> / AWG 26-16
Material	PCB solder termination
Temperature range	- signal contact $\Phi 0.6 \text{ mm}$
Flammability acc. to UL 94	- reference to 3.5 mm
	bulkhead mounted housing



## Crimp terminal for D-Sub contacts



Inserts	Designation	Order No.
Male	HR23-012-MC	181 012 010 0001
Female	HR23-012-FC	181 012 020 0001

## Solder terminal



Inserts	Designation	Order No.
Male	HR23-012-MST	181 012 013 0001
Female	HR23-012-FST	181 012 023 0001
	Reverse coding	
Male	HR23-012R-MST	181 012 013 0101
Female	HR23-012R-FST	181 012 023 0101

PCB solder termination <sup>2)</sup>

Inserts	Designation	Order No.
Male	HR23-012-MTHT <sup>2)</sup>	181 012 014 0001
Female	HR23-012-FTHT <sup>2)</sup>	181 012 024 0001
	Reverse coding	
Male	HR23-012R-MTHT <sup>2)</sup>	181 012 014 0101
Female	HR23-012R-FTHT <sup>2)</sup>	181 012 024 0101

## Accessories

## Crimp contacts 5A

Contact resistance  $\leq 3 \text{ m}\Omega$   
gold plated

Wire gauge(mm <sup>2</sup> )	Male	Order No.	Female	Order No.
0.09-0.25	CSGM-0.25	101 014 210 0101	CSGF-0.25	101 014 220 0101
0.13-0.33	CSGM-0.33	101 014 210 0201	CSGF-0.33	101 014 220 0201
0.33-0.52	CSGM-0.52	101 014 210 0501	CSGF-0.52	101 014 220 0501
0.33-0.82	CSGM-0.82	101 014 210 0701	CSGF-0.82	101 014 220 0701

\*Please find the details of crimp contact tools on page 29-02~29-05.\*Please find the details of crimp contact tools on page 29-02~29-05.

Notes: The tools for crimp terminal may influence the product quality and stability. Please select the tools recognized by our company.

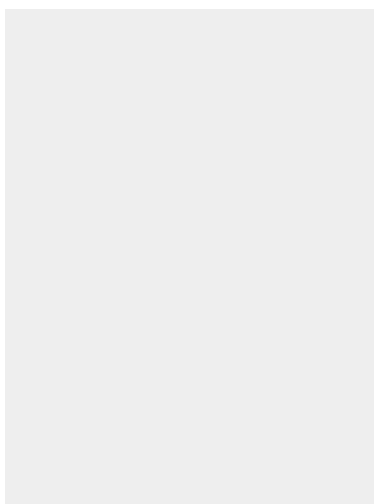

## Contact arrangement: mating side

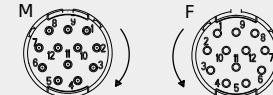

## Reverse coding

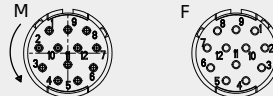

## PCB layout

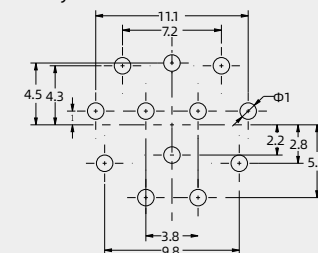

2) Suitable only for bulkhead mounted housings:HR23-BK-D2.7,HR23-BK/R-OD2.7 and HR23-BK/R-OM2.5

## HR23-017 Circular inserts

25V~/60V- 7A

## Inserts

Hoods/Housings: size HR23 ,detail please find the page22-09~22-11.

## Technical characteristics

Specifications	
Specifications	DIN EN 60 664 DIN EN 61 984
Approvals	
Inserts	Contacts
Number of contacts	17
Electrical data acc. to EN 61 984	Material
Rated current	copper alloy
-signal contact	Surface
Rated voltage	gold plated
Pollution degree	Contact resistance
Rated impulse voltage	$\leq 5 \text{ m}\Omega$
Insulation resistance	Crimp termination
Material	- D-Sub contact
Temperature range	0.09-0.82 mm <sup>2</sup> / AWG 28-18
Flammability acc. to UL 94	Solder termination
	- signal contact
	0.14-1.0 mm <sup>2</sup> / AWG 26-16
	PCB solder termination
	- signal contact
	$\Phi 0.6 \text{ mm}$
	- reference to
	3.5 mm
	bulkhead mounted
	housing



## Crimp terminal for D-Sub contacts



Inserts	Designation	Order No.
Male	HR23-017-MC	181 017 010 0001
Female	HR23-017-FC	181 017 020 0001

## Solder terminal



Inserts	Designation	Order No.
Male	HR23-017-MST	181 017 013 0001
Female	HR23-017-FST	181 017 023 0001
	Reverse coding	
Male	HR23-017R-MST	181 017 013 0101
Female	HR23-017R-FST	181 017 023 0101

PCB solder termination<sup>2)</sup>

Inserts	Designation	Order No.
Male	HR23-017-MTHT <sup>2)</sup>	181 017 014 0001
Female	HR23-017-FTHT <sup>2)</sup>	181 017 024 0001
	Reverse coding	
Male	HR23-017R-MTHT <sup>2)</sup>	181 017 014 0101
Female	HR23-017R-FTHT <sup>2)</sup>	181 017 024 0101

## Accessories

## Crimp contacts 5A

Contact resistance  $\leq 3 \text{ m}\Omega$   
gold plated

Wire gauge(mm <sup>2</sup> )	Male	Order No.	Female	Order No.
0.09-0.25	CSGM-0.25	101 014 210 0101	CSGF-0.25	101 014 220 0101
0.13-0.33	CSGM-0.33	101 014 210 0201	CSGF-0.33	101 014 220 0201
0.33-0.52	CSGM-0.52	101 014 210 0501	CSGF-0.52	101 014 220 0501
0.33-0.82	CSGM-0.82	101 014 210 0701	CSGF-0.82	101 014 220 0701

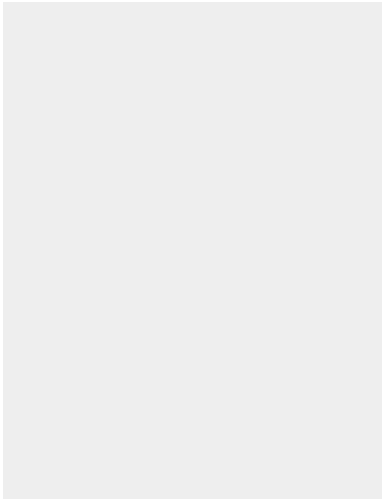

## Contact arrangement: mating side

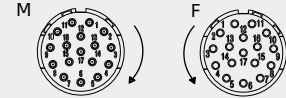

## Reverse coding



## PCB layout

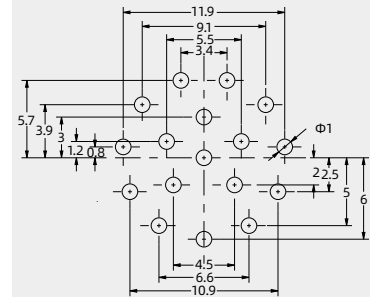

2) Suitable only for bulkhead mounted housings:HR23-BK-D2.7,HR23-BK/R-OD2.7 and HR23-BK/R-OM2.5

\*Please find the details of crimp contact tools on page 29-02~29-05.\*Please find the details of crimp contact tools on page 29-02~29-05.

Notes: The tools for crimp terminal may influence the product quality and stability. Please select the tools recognized by our company.

## HR23-019 Circular inserts

25V~/60V- 10/7A

## Inserts

Hoods/Housings: size HR23 ,detail please find the page22-09~22-11.

## Technical characteristics

## Specifications

Specifications	DIN EN 60 664
	DIN EN 61 984

## Approvals

Inserts		Contacts	
Number of contacts	19	Material	copper alloy
Electrical data acc. to EN 61 984		Surface	gold plated
Rated current		Contact resistance	≤ 5 mΩ
-power contact	3x10A	Solder terminal	
-signal contact	16x7A	-power contact	0.14-2.5 mm <sup>2</sup> / AWG 26-14
Rated voltage	25 V~/60 V-	-signal contact	0.14-1.0 mm <sup>2</sup> / AWG 26-16
Pollution degree	3		
Rated impulse voltage	1.5 kV		
Insulation resistance	≥ 10 <sup>12</sup> Ω		
Material	PBT		
Temperature range	-40°C ...+130°C		
Flammability acc. to UL 94	V0		

## Solder terminal



Inserts	Designation	Order No.
Male	HR23-019-MST	181 019 013 0001
Female	HR23-019-FST	181 019 023 0001
Reverse coding		
Male	HR23-019R-MST	181 019 013 0101
Female	HR23-019R-FST	181 019 023 0101

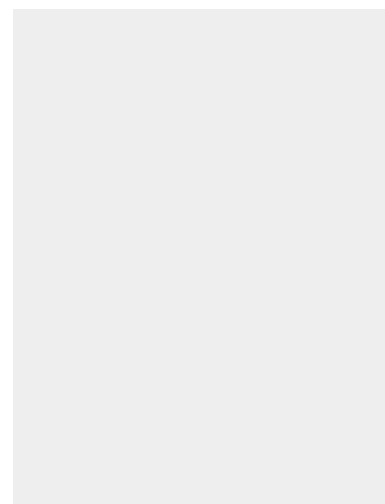

## Contact arrangement: mating side

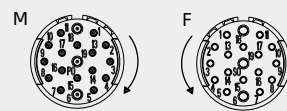

## Reverse coding



## HR23 Housing material

Housing material	
Material	Copper zinc alloy
Surface	Nickel-plated
Sealing	FPM
Temperature range	-40°C ...+130°C
Degree of protection	IP 67

### Hoods, top-entry

Install or remove this kind of product need to use the HR23-TL02/N tools.



screw	Designation	Order No.
PG11	HR23-TE-PG11	181 000 410 1002
M20	HR23-TE-M20	181 000 410 1001

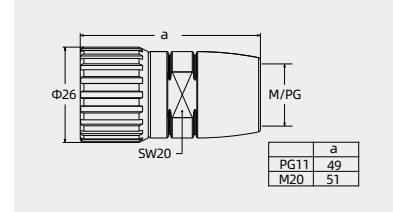

Mounted with cable gland to achieve EMC function.

### Hoods, top-entry, EMC version



screw	Designation	Order No.
	HR23-TE-EMC	181 000 410 2003

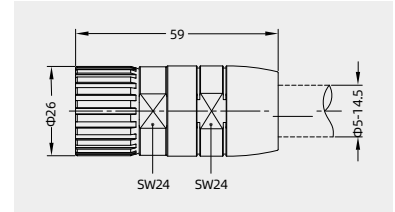

### Hood, entry 90°



screw	Designation	Order No.
PG11	HR23-SE-PG11	181 000 510 1002
M20	HR23-SE-M20	181 000 510 1001

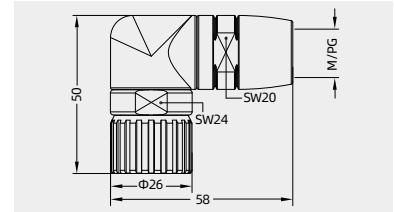

Mounted with cable gland to achieve EMC function.

### Hood, entry 90°



screw	Designation	Order No.
PG11	HR23-SES-PG11	181 000 510 1102

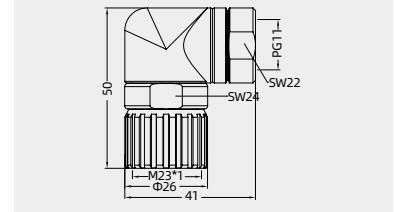

### Screw cover , for hoods with rope



screw	Designation	Order No.
	HR23-MCV-M2	181 000 010 9001

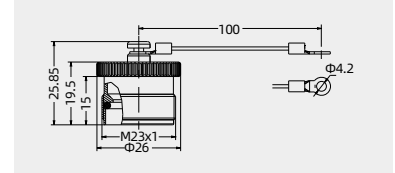

### Cable gland



screw	Designation	Order No.
PG11	WNAC-PG11(D5-10)	102 117 003 1001
M20	WNAC-M20(D6-12)	102 117 015 1001

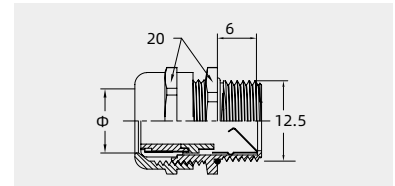

### Cable gland

Recommended use



screw	Designation	Order No.
PG11	WNACP-PG11(D5.5-8.5)	102 117 018 1503
M20	WNACP-M20(D5.5-8.5)	102 117 018 1505

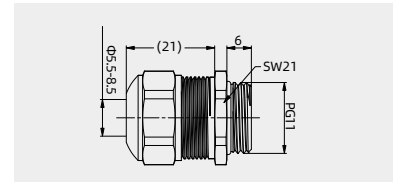

HR23 Housing material

Degree of protection: IP67

Housings, bulkhead mounting

front wall assembly with central locking PG13.5



screw	Designation	Order No.
PG13.5	HR23-BK-PG13.5	181 000 310 1004

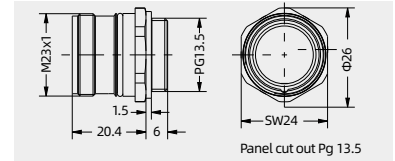

Housings, bulkhead mounting

front wall assembly,with central locking M20



screw	Designation	Order No.
M20	HR23-BK-M20	181 000 310 1003

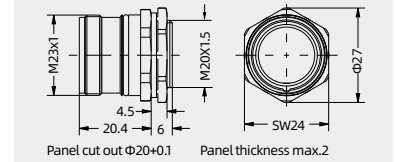

Housings, bulkhead mounting

front wall assembly,with flat sealing and 4 Ø2.7 holes



screw	Designation	Order No.
---	HR23-BK-D2.7	181 000 310 1001

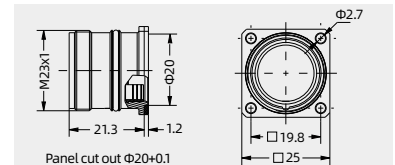

Housings, bulkhead mounting

front wall assembly,with O-ring sealing and 4 Ø3.2 holes



screw	Designation	Order No.
---	HR23-BK-OD3.2	181 000 310 1002

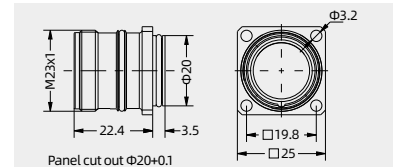

Housings, bulkhead mounting

front wall assembly,with O-ring sealing and 4 Ø2.7 holes

HR23-TL03 tools are needed for installation and removal



screw	Designation	Order No.
---	HR23-BK-SE-OD2.7	181 000 610 1001

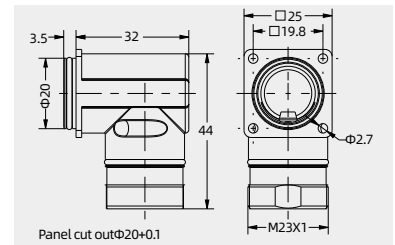

Housings, bulkhead mounting

front wall assembly,with O-ring sealing and 4 Ø2.7 holes. suitable for positioning rotation,can match HR23 series inserts, (except PCB Solder series)



screw	Designation	Order No.
---	HR23-BKP-SE-OD2.7	181 000 610 1101

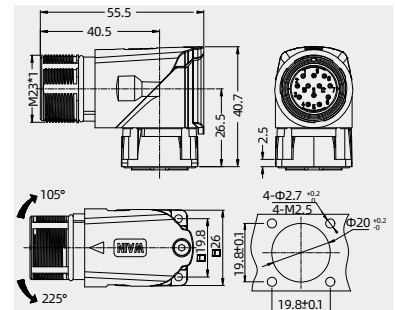

Housings, bulkhead mounting

front wall assembly,with O-ring sealing and 4 Ø3.2 holes. suitable for positioning rotation,can match HR23 series inserts, (except PCB Solder series)



screw	Designation	Order No.
---	HR23-BKP28.8-SE-OD3.2	181 000 610 1102

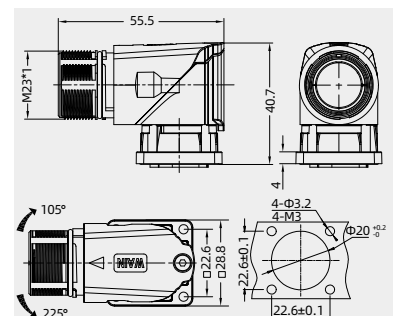

HR23 Housing material

Degree of protection: IP67

Housings, bulkhead mounting

back wall assembly, with O-ring sealing and 4  $\Phi 2.7$  holes



screw	Designation	Order No.
---	HR23-BK/R-OD2.7	181 000 310 1101

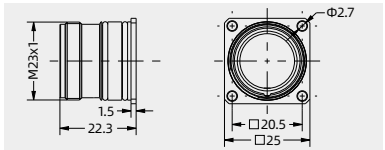

When using counter sunk screws, Panel cut out  $\Phi 23+0.1$ , Panel thickness: 2.7-3.5,

Housings, bulkhead mounting

back wall assembly, with O-ring sealing and 4 M2.5 holes



screw	Designation	Order No.
---	HR23-BK/R-OM2.5	181 000 310 1102

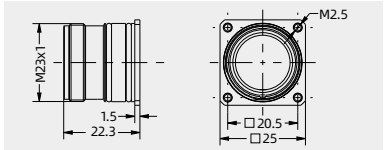

When using counter sunk screws, Panel cut out  $\Phi 23+0.1$ , Panel thickness: 2.7-3.5,

Housings, bulkhead mounting

back wall assembly, with O-ring sealing and 4 M3.0 holes



screw	Designation	Order No.
---	HR23-BK/R-OM3.0	181 000 310 1103

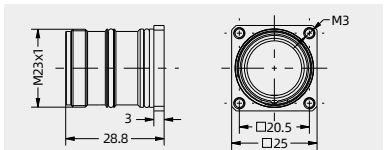

When using counter sunk screws, Panel cut out  $\Phi 23+0.1$ , Panel thickness: 3.5-8.5

Housings, bulkhead mounting

back wall assembly, with central locking M25



screw	Designation	Order No.
M25	HR23-BK/R-OM25	181 000 310 1104

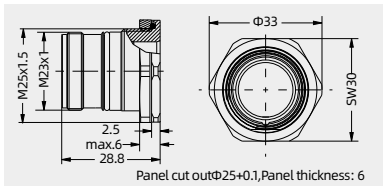

Panel cut out  $\Phi 25+0.1$ , Panel thickness: 6

EMC Housings, cable to cable

back wall assembly, with central locking M25



screw	Designation	Order No.
M25	HR23-CCT/R-OM25	181 000 710 1004

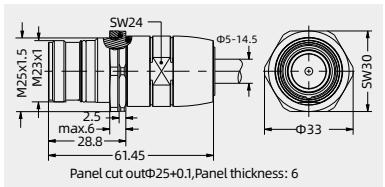

Panel cut out  $\Phi 25+0.1$ , Panel thickness: 6

Housings, cable to cable, top entry



screw	Designation	Order No.
M20	HR23-CCT-M20	181 000 710 1001
PG11	HR23-CCT-PG11	181 000 710 1002

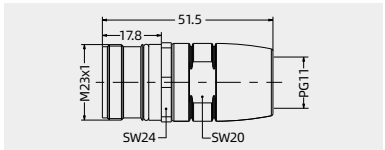

Housings, cable to cable, top entry

EMC version



screw	Designation	Order No.
---	HR23-CCT-EMC	181 000 710 2003

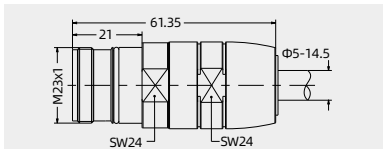

Install or remove this kind of product need to use the HR23-TL01 tools.

Screw cover

for bulkhead mounted and cable to cable housings



screw	Designation	Order No.
---	HR23-MCV-F	181 000 010 9003



Screw cover

for bulkhead mounted and cable to cable housings, with rope



screw	Designation	Order No.
---	HR23-MCV-F2	181 000 010 9002

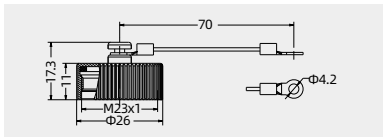

## HR23 Assembly manuals

Hood and Housing	Cable stripping length x
HR23-CCT/R-OM25	26 mm
HR23-TE-PG11	20 mm
HR23-TE-EMC	26 mm
HR23-SE-PG11	30 mm
HR23-CCT-PG11	20 mm
HR23-CCT-EMC	26 mm
HR23-BK-SE-OD2.7	30 mm



### Standard hood and housing

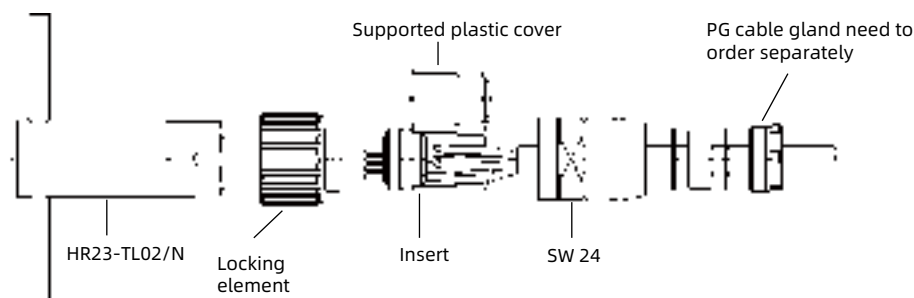

### EMC hoods

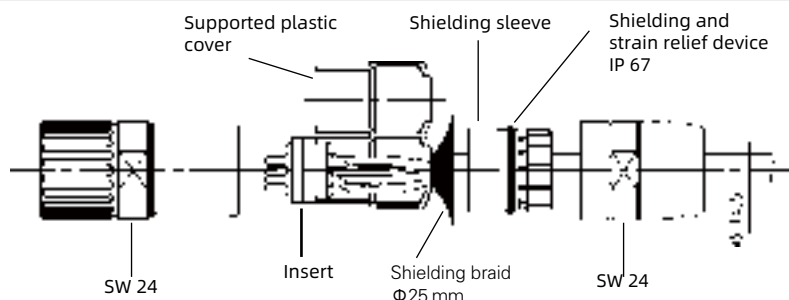

### Right angled bulkhead mounted housing

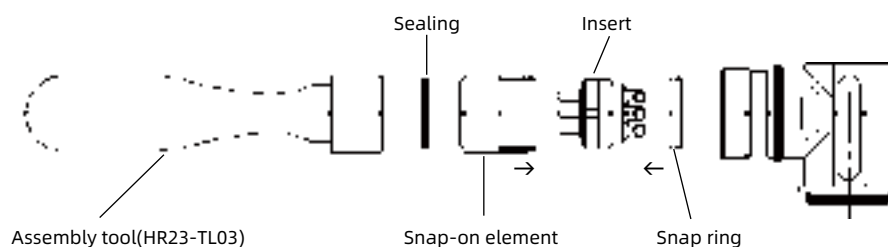

### Right angled bulkhead mounted housing: HR23-BKP-SE-OD2.7

1: Pull out the upper cover horizontally, and then take out the inner insert fixed part.

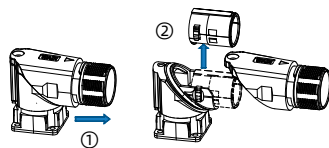

2: insert wiring

a. The cable passes through the fixed base.  
b. Strip the wire insulation husk, and then weld it to the pins of the insert.



3: install the insert fixed part  
a. Fasten the open fixed part with the insert; the location gap of the insert should align with the location salient point of the fixed part.  
b. Insert the fixed part which installed the insert to the slot of the base.

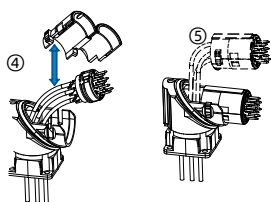

4: Lock the upper cover, and the installation is completed.

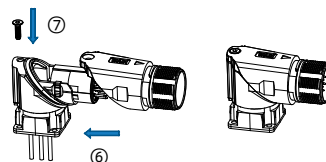

## HR23 Tools

### Tools



Application	Designation	Order No.
for bulkhead mounted and cable to cable housings and hoods: HR23-CCT-EMC	HR23-TL01/N	198 001 003 0004

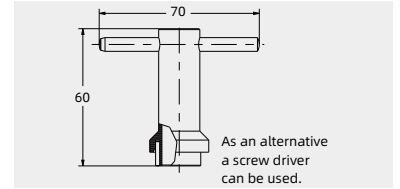

### Tools



Description	Designation	Order No.
for hoods: HR23-TE-PG11 HR23-TE-M20	HR23-TL02/N	198 001 003 0005

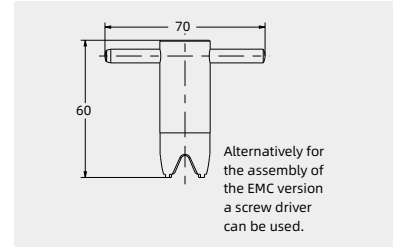

### Tools



Description	Designation	Order No.
for angled bulkhead mounted housings: HR23-BK-SE-OD2.7	HR23-TL03	198 001 003 0006

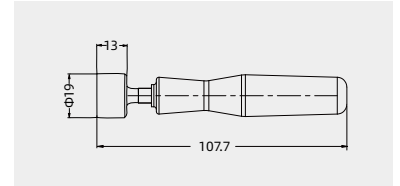

### Tools



Description	Designation	Order No.
for housings: (except angled bulkhead mounted and EMC housings)	HR23-TL04	198 001 003 0014

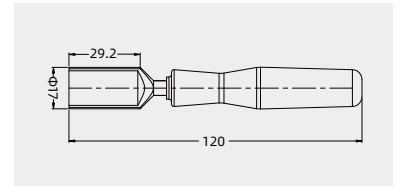





HR23

## MR23 Circular power connectors



## MR23 Circular connector

300V- 20A

## Technical characteristics

Specifications			
Specifications	DIN EN 60 664		
	DIN EN 61 984		
Approvals			
Electrical data		Mechanical data	
Number of contacts	6	7	Housing material
Rated current	20A	20A	Housing surface
mm <sup>2</sup> / AWG	(0.35-2.5 mm <sup>2</sup> / AWG 22-14)		Contact resistance
Rated voltage	300 V	300 V	Insulating bodies
Rated impulse voltage	2.5 kV	2.5 kV	Contact material
Pollution degree	3	3	Contact surface
Flammability acc. to UL 94	V0 (UL94)	V0 (UL94)	Mechanical working life
Overvoltage categorie	III	III	Degree of protection
			Limiting temperature

Forward coding, Crimp terminal  
order crimp contacts separately

Contacts	Cable outlet	Designation	Order No.
6	4.5-8mm	MR23-006-CCT-D8-SH	181 006 700 2001
	6-10mm	MR23-006-CCT-D10-SH	181 006 700 2002
	9-14.5mm	MR23-006-CCT-D14.5-SH	181 006 700 2003
7	4.5-8mm	MR23-007-CCT-D8-SH	181 007 700 2001
	6-10mm	MR23-007-CCT-D10-SH	181 007 700 2002
	9-14.5mm	MR23-007-CCT-D14.5-SH	181 007 700 2003

Reverse coding, Crimp terminal  
order crimp contacts separately

Contacts	Cable outlet	Designation	Order No.
6	4.5-8mm	MR23-006R-CCT-D8-SH	181 006 700 2004
	6-10mm	MR23-006R-CCT-D10-SH	181 006 700 2005
	9-14.5mm	MR23-006R-CCT-D14.5-SH	181 006 700 2006
7	4.5-8mm	MR23-007R-CCT-D8-SH	181 007 700 2004
	6-10mm	MR23-007R-CCT-D10-SH	181 007 700 2005
	9-14.5mm	MR23-007R-CCT-D14.5-SH	181 007 700 2006

## Crimp contacts

## Crimp contacts 20A

20A



NO.	Wire gauge(mm <sup>2</sup> )	Male	Order No.
①	0.35-2.5	MR23-MC20G-2.5	101 020 210 1001
NO.	Wire gauge(mm <sup>2</sup> )	Female	Order No.
①	0.35-2.5	MR23-FC20G-2.5	101 020 220 1001

## Tools

## Crimping tool



Wire gauge	Designation	Order No.
0.14-4 mm <sup>2</sup>	TL28-2	198 001 001 0039

Notes: The tools for crimp terminal may influence the product quality and stability. Please select the tools recognized by our company.

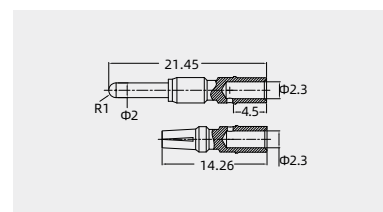
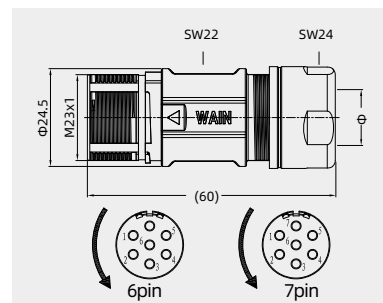
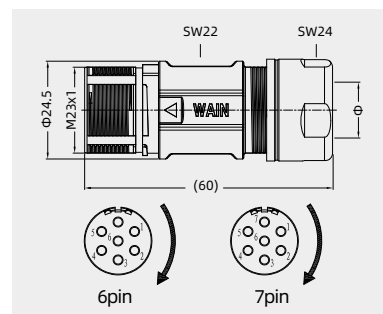
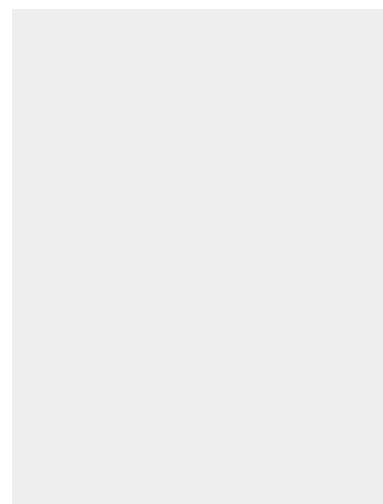

## MR23 Circular connector

300V- 20A

## Technical characteristics

Specifications			
Specifications	DIN EN 60 664		
	DIN EN 61 984		
Approvals			
Electrical data		Mechanical data	
Number of contacts	6	7	Housing material
Rated current	20A	20A	Housing surface
mm <sup>2</sup> / AWG	(0.35-2.5 mm <sup>2</sup> / AWG 22-14)		Contact resistance
Rated voltage	300 V	300 V	Insulating bodies
Rated impulse voltage	2.5 kV	2.5 kV	Contact material
Pollution degree	3	3	Contact surface
Flammability acc. to UL 94	V0 (UL94)	V0 (UL94)	Mechanical working life
Overvoltage categorie	III	III	Degree of protection
			Limiting temperature

Forward coding, Crimp terminal  
order crimp contacts separately

Contacts	Cable outlet	Designation	Order No.
6	4.5-8mm	MR23-006-CCT/R-D8-SH	181 006 700 2007
	6-10mm	MR23-006-CCT/R-D10-SH	181 006 700 2008
	9-14.5mm	MR23-006-CCT/R-D14.5-SH	181 006 700 2009
7	4.5-8mm	MR23-007-CCT/R-D8-SH	181 007 700 2007
	6-10mm	MR23-007-CCT/R-D10-SH	181 007 700 2008
	9-14.5mm	MR23-007-CCT/R-D14.5-SH	181 007 700 2009

Reverse coding, Crimp terminal  
order crimp contacts separately

Contacts	Cable outlet	Designation	Order No.
6	4.5-8mm	MR23-006R-CCT/R-D8-SH	181 006 700 2010
	6-10mm	MR23-006R-CCT/R-D10-SH	181 006 700 2011
	9-14.5mm	MR23-006R-CCT/R-D14.5-SH	181 006 700 2012
7	4.5-8mm	MR23-007R-CCT/R-D8-SH	181 007 700 2010
	6-10mm	MR23-007R-CCT/R-D10-SH	181 007 700 2011
	9-14.5mm	MR23-007R-CCT/R-D14.5-SH	181 007 700 2012

## Crimp contacts

## Crimp contacts 20A

20A



NO.	Wire gauge(mm <sup>2</sup> )	Male	Order No.
①	0.35-2.5	MR23-MC20G-2.5	101 020 210 1001
NO.	Wire gauge(mm <sup>2</sup> )	Female	Order No.
①	0.35-2.5	MR23-FC20G-2.5	101 020 220 1001

## Tools

## Crimping tool



Wire gauge	Designation	Order No.
0.14-4 mm <sup>2</sup>	TL28-2	198 001 001 0039

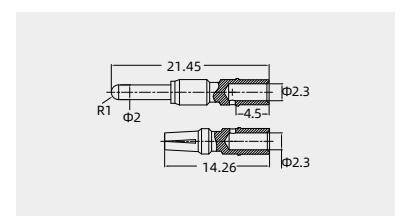
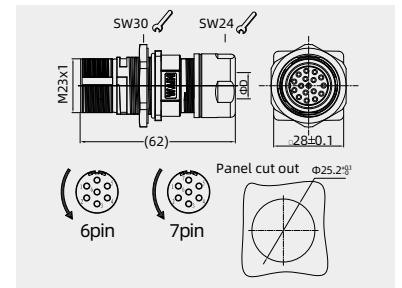
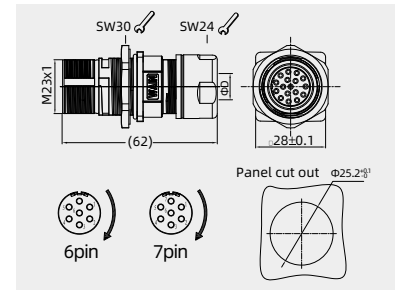
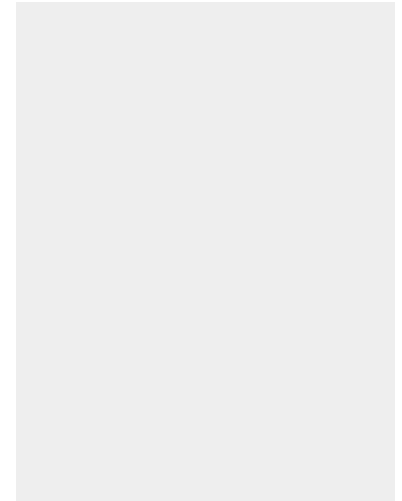

Notes: The tools for crimp terminal may influence the product quality and stability. Please select the tools recognized by our company.

## MR23 Circular connector

160V- 10A

## Technical characteristics

Specifications			
Specifications	DIN EN 60 664		
	DIN EN 61 984		
Approvals			
Electrical data		Mechanical data	
Number of contacts	9(8+1)	Housing material	copper alloy,zinc alloy
Rated current	10A	Housing surface	Nickel-plated
mm <sup>2</sup> / AWG	0.03-1.0+0.35-2.5	Contact resistance	≤ 5 mΩ
Rated voltage	160 V	Insulating bodies	PBT
Rated impulse voltage	2.5 kV	Contact material	copper alloy
Pollution degree	3	Contact surface	gold plated
Flammability acc. to UL 94	V0 (UL94)	Mechanical working life	>500
Overvoltage categorie	III	Degree of protection	IP67
		Limiting temperature	-40°C ...+130°C

Forward coding, Crimp terminal  
order crimp contacts separately

Contacts	Cable outlet	Designation	Order No.
9	4.5-8mm	MR23-009-CCT-D8-SH	181 009 700 2501
	6-10mm	MR23-009-CCT-D10-SH	181 009 700 2502
	9-14.5mm	MR23-009-CCT-D14.5-SH	181 009 700 2503

Reverse coding, Crimp terminal  
order crimp contacts separately

Contacts	Cable outlet	Designation	Order No.
9	4.5-8mm	MR23-009R-CCT-D8-SH	181 009 700 2504
	6-10mm	MR23-009R-CCT-D10-SH	181 009 700 2500
	9-14.5mm	MR23-009R-CCT-D14.5-SH	181 009 700 2505

## Crimp contacts

## Crimp contacts 9A

9A



NO.	Wire gauge(mm <sup>2</sup> )	Male	Order No.
①	0.03-0.34	M23-MC9G-0.34	101 031 210 2501
②	0.14-1.0	M23-MC9G-1.0	101 031 210 0801

NO.	Wire gauge(mm <sup>2</sup> )	Female	Order No.
①	0.03-0.34	M23-FC9G-0.34	101 031 220 2501
②	0.14-1.0	M23-FC9G-1.0	101 031 220 0801

## Crimp contacts 20A

20A



NO.	Wire gauge(mm <sup>2</sup> )	Male	Order No.
①	0.35-2.5	MR23-MC20G-2.5	101 020 210 1001

NO.	Wire gauge(mm <sup>2</sup> )	Female	Order No.
①	0.35-2.5	MR23-FC20G-2.5	101 020 220 1001

## Tools

Crimping tool



Wire gauge	Designation	Order No.
0.14-4 mm <sup>2</sup>	TL28-2	198 001 001 0039

Notes: The tools for crimp terminal may influence the product quality and stability. Please select the tools recognized by our company.

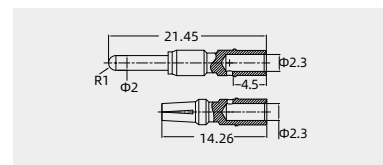
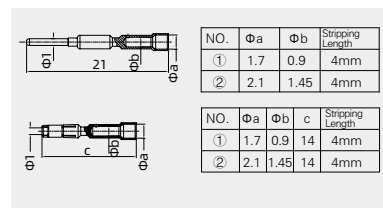
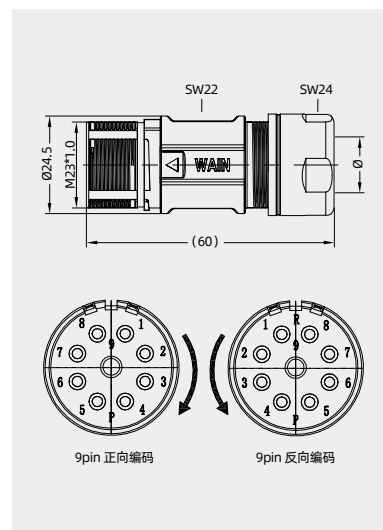
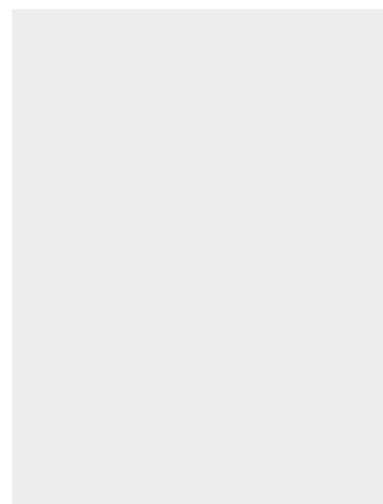

Accessories

Stamped contacts

Stamped contacts



NO.	Wire gauge(mm <sup>2</sup> )	Male	Order No.
①	0.08-0.2	M23-MC9G-0.2P	101 031 210 0150
②	0.2-0.52	M23-MC9G-0.52P	101 031 210 0550
③	0.75-1.0	M23-MC9G-1.0P	101 031 210 0850
NO.	Wire gauge(mm <sup>2</sup> )	Female	Order No.
①	0.08-0.2	M23-FC9G-0.2P	101 031 220 0150
②	0.2-0.52	M23-FC9G-0.52P	101 031 220 0550
③	0.75-1.0	M23-FC9G-1.0P	101 031 220 0850

coil stock



Note: 10kpcs/volume

Tools

Terminal stamping machir



Wire gauge	Designation	Order No.
	M23-XC9G-MJ	903 020 000 0548

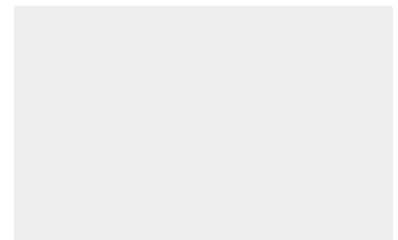
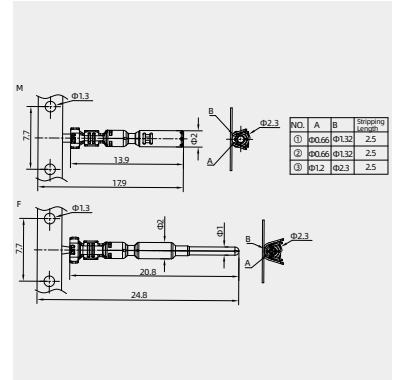

## MR23 Circular connector

160V- 10A

## Technical characteristics

Specifications			
Specifications	DIN EN 60 664		
	DIN EN 61 984		
Approvals			
Electrical data		Mechanical data	
Number of contacts	9	Housing material	copper alloy, zinc alloy
Rated current	10A	Housing surface	Nickel-plated
mm <sup>2</sup> / AWG	0.14-1.0 + 0.35-2.5	Contact resistance	≤ 5 mΩ
Rated voltage	160 V	Insulating bodies	PBT
Rated impulse voltage	2.5 kV	Contact material	copper alloy
Pollution degree	3	Contact surface	gold plated
Flammability acc. to UL 94	V0 (UL94)	Mechanical working life	>500
Overvoltage categorie	III	Degree of protection	IP67
		Limiting temperature	-40°C ...+130°C

Forward coding, Crimp terminal  
order crimp contacts separately

Contacts	Cable outlet	Designation	Order No.
9	4.5-8mm	MR23-009/B-CCT-D8-SH	181 009 700 2506
	6-10mm	MR23-009/B-CCT-D10-SH	181 009 700 2507
	9-14.5mm	MR23-009/B-CCT-D14.5-SH	181 009 700 2508

Reverse coding, Crimp terminal  
order crimp contacts separately

Contacts	Cable outlet	Designation	Order No.
9	4.5-8mm	MR23-009R/B-CCT-D8-SH	181 009 700 2509
	6-10mm	MR23-009R/B-CCT-D10-SH	181 009 700 2510
	9-14.5mm	MR23-009R/B-CCT-D14.5-SH	181 009 700 2511

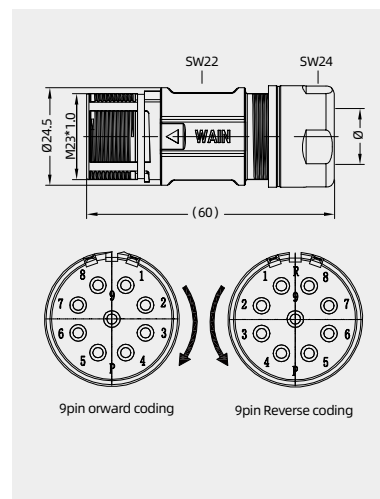
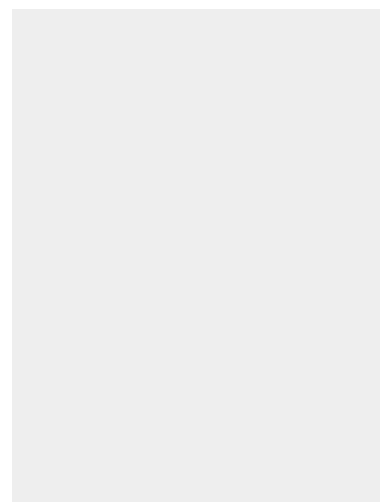

## Crimp contacts

## Crimp contacts 9A

9A



NO.	Wire gauge(mm <sup>2</sup> )	Male	Order No.
①	0.03-0.34	M23-MC9G-0.34	101 031 210 2501
②	0.14-1.0	M23-MC9G-1.0	101 031 210 0801

NO.	Wire gauge(mm <sup>2</sup> )	Female	Order No.
①	0.03-0.34	M23-FC9G-0.34	101 031 220 2501
②	0.14-1.0	M23-FC9G-1.0	101 031 220 0801

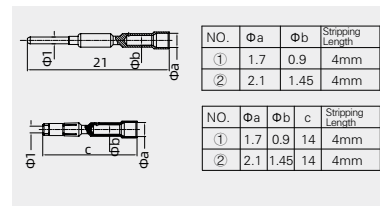

## Tools

## Crimping tool



Wire gauge	Designation	Order No.
0.14-4 mm <sup>2</sup>	TL28-2	198 001 001 0039

Notes: The tools for crimp terminal may influence the product quality and stability. Please select the tools recognized by our company.

Accessories

Stamped contacts

Stamped contacts



coil stock



Note: 10kpcs/volume

Tools

Terminal stamping machir



NO.	Wire gauge(mm <sup>2</sup> )	Male	Order No.
①	0.08-0.2	M23-MC9G-0.2P	101 031 210 0150
②	0.2-0.52	M23-MC9G-0.52P	101 031 210 0550
③	0.75-1.0	M23-MC9G-1.0P	101 031 210 0850
NO.	Wire gauge(mm <sup>2</sup> )	Female	Order No.
①	0.08-0.2	M23-FC9G-0.2P	101 031 220 0150
②	0.2-0.52	M23-FC9G-0.52P	101 031 220 0550
③	0.75-1.0	M23-FC9G-1.0P	101 031 220 0850

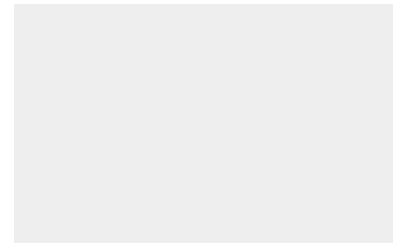
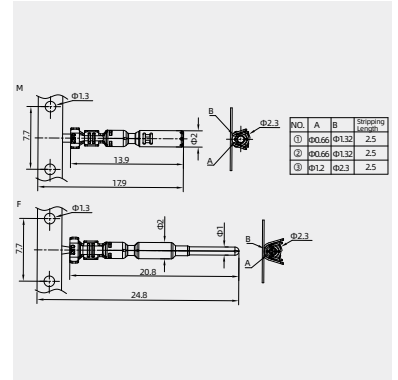



## MR23 Circular connector

160V- 10A

## Technical characteristics

Specifications			
Specifications	DIN EN 60 664		
	DIN EN 61 984		
Approvals			
Electrical data		Mechanical data	
Number of contacts	9	Housing material	copper alloy,zinc alloy
Rated current	10A	Housing surface	Nickel-plated
mm <sup>2</sup> / AWG	0.14-1.0 + 0.35-2.5	Contact resistance	≤ 5 mΩ
Rated voltage	160 V	Insulating bodies	PBT
Rated impulse voltage	2.5 kV	Contact material	copper alloy
Pollution degree	3	Contact surface	gold plated
Flammability acc. to UL 94	V0 (UL94)	Mechanical working life	>500
Overvoltage categorie	III	Degree of protection	IP67
		Limiting temperature	-40°C ...+130°C

Forward coding, Crimp terminal  
order crimp contacts separately

Contacts	Cable outlet	Designation	Order No.
9	4.5-8mm	MR23-009-CCT/R-D8-SH	181 009 700 2512
	6-10mm	MR23-009-CCT/R-D10-SH	181 009 700 2513
	9-14.5mm	MR23-009-CCT/R-D14.5-SH	181 009 700 2514

Reverse coding, Crimp terminal  
order crimp contacts separately

Contacts	Cable outlet	Designation	Order No.
9	4.5-8mm	MR23-009R-CCT/R-D8-SH	181 009 700 2515
	6-10mm	MR23-009R-CCT/R-D10-SH	181 009 700 2516
	9-14.5mm	MR23-009R-CCT/R-D14.5-SH	181 009 700 2517

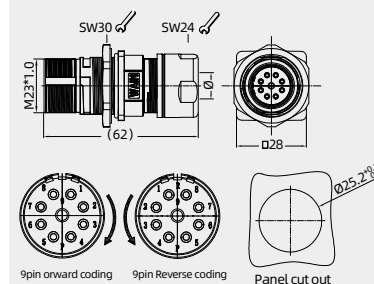

## Crimp contacts

## Crimp contacts 9A

9A



NO.	Wire gauge(mm <sup>2</sup> )	Male	Order No.
①	0.03-0.34	M23-MC9G-0.34	101 031 210 2501
②	0.14-1.0	M23-MC9G-1.0	101 031 210 0801

NO.	Wire gauge(mm <sup>2</sup> )	Female	Order No.
①	0.03-0.34	M23-FC9G-0.34	101 031 220 2501
②	0.14-1.0	M23-FC9G-1.0	101 031 220 0801

NO.	Φa	Φb	Stripping Length
①	1.7	0.9	4mm
②	2.1	1.45	4mm

NO.	Φa	Φb	c	Stripping Length
①	1.7	0.9	14	4mm
②	2.1	1.45	14	4mm

## Crimp contacts 20A

20A



NO.	Wire gauge(mm <sup>2</sup> )	Male	Order No.
①	0.35-2.5	MR23-MC20G-2.5	101 020 210 1001

NO.	Wire gauge(mm <sup>2</sup> )	Female	Order No.
①	0.35-2.5	MR23-FC20G-2.5	101 020 220 1001

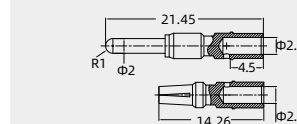

## Tools

## Crimping tool



Wire gauge	Designation	Order No.
0.14-4 mm <sup>2</sup>	TL28-2	198 001 001 0039

Notes: The tools for crimp terminal may influence the product quality and stability. Please select the tools recognized by our company.

Accessories

Stamped contacts

Stamped contacts



NO.	Wire gauge(mm <sup>2</sup> )	Male	Order No.
①	0.08-0.2	M23-MC9G-0.2P	101 031 210 0150
②	0.2-0.52	M23-MC9G-0.52P	101 031 210 0550
③	0.75-1.0	M23-MC9G-1.0P	101 031 210 0850
NO.	Wire gauge(mm <sup>2</sup> )	Female	Order No.
①	0.08-0.2	M23-FC9G-0.2P	101 031 220 0150
②	0.2-0.52	M23-FC9G-0.52P	101 031 220 0550
③	0.75-1.0	M23-FC9G-1.0P	101 031 220 0850

coil stock



Note: 10kpcs/volume

Tools

Terminal stamping machir



Wire gauge	Designation	Order No.
	M23-XC9G-MJ	903 020 000 0548

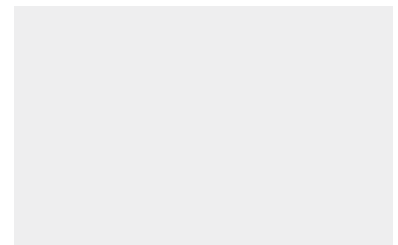
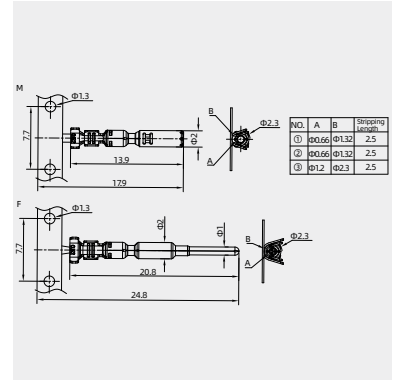

## MR23 Circular connector

160V- 10A

## Technical characteristics

Specifications			
Specifications	DIN EN 60 664		
	DIN EN 61 984		
Approvals			
Electrical data		Mechanical data	
Number of contacts	9	Housing material	copper alloy,zinc alloy
Rated current	10A	Housing surface	Nickel-plated
mm <sup>2</sup> / AWG	0.03-1.0	Contact resistance	≤ 5 mΩ
Rated voltage	160 V	Insulating bodies	PBT
Rated impulse voltage	2.5 kV	Contact material	copper alloy
Pollution degree	3	Contact surface	gold plated
Flammability acc. to UL 94	V0 (UL94)	Mechanical working life	>500
Overvoltage categorie	III	Degree of protection	IP67
		Limiting temperature	-40°C ...+130°C

Forward coding, Crimp terminal  
order crimp contacts separately

Contacts	Cable outlet	Designation	Order No.
9	4.5-8mm	MR23-009/B-CCT/R-D8-SH	181 009 700 2518
	6-10mm	MR23-009/B-CCT/R-D10-SH	181 009 700 2519
	9-14.5mm	MR23-009/B-CCT/R-D14.5-SH	181 009 700 2520

Reverse coding, Crimp terminal  
order crimp contacts separately

Contacts	Cable outlet	Designation	Order No.
9	4.5-8mm	MR23-009R/B-CCT/R-D8-SH	181 009 700 2521
	6-10mm	MR23-009R/B-CCT/R-D10-SH	181 009 700 2522
	9-14.5mm	MR23-009R/B-CCT/R-D14.5-SH	181 009 700 2523

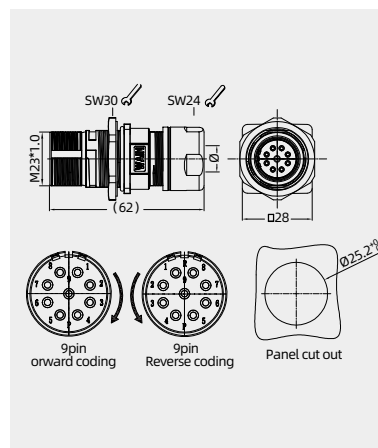
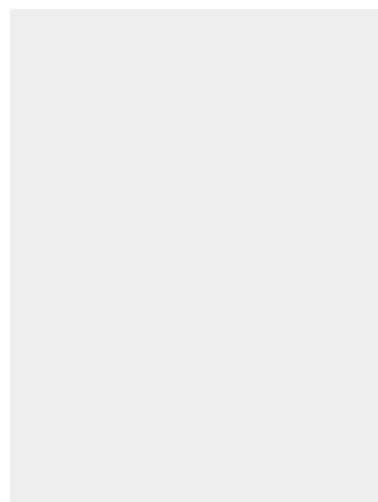

## Crimp contacts

## Crimp contacts 9A

9A



NO.	Wire gauge(mm <sup>2</sup> )	Male	Order No.
①	0.03-0.34	M23-MC9G-0.34	101 031 210 2501
②	0.14-1.0	M23-MC9G-1.0	101 031 210 0801

NO.	Wire gauge(mm <sup>2</sup> )	Female	Order No.
①	0.03-0.34	M23-FC9G-0.34	101 031 220 2501
②	0.14-1.0	M23-FC9G-1.0	101 031 220 0801

NO.	Φa	Φb	Stripping Length
①	1.7	0.9	4mm
②	2.1	1.45	4mm

NO.	Φa	Φb	c	Stripping Length
①	1.7	0.9	14	4mm
②	2.1	1.45	14	4mm

## Tools

## Crimping tool



Wire gauge	Designation	Order No.
0.14-4 mm <sup>2</sup>	TL28-2	198 001 001 0039

Notes: The tools for crimp terminal may influence the product quality and stability. Please select the tools recognized by our company.

Accessories

Stamped contacts

Stamped contacts



NO.	Wire gauge(mm <sup>2</sup> )	Male	Order No.
①	0.08-0.2	M23-MC9G-0.2P	101 031 210 0150
②	0.2-0.52	M23-MC9G-0.52P	101 031 210 0550
③	0.75-1.0	M23-MC9G-1.0P	101 031 210 0850
NO.	Wire gauge(mm <sup>2</sup> )	Female	Order No.
①	0.08-0.2	M23-FC9G-0.2P	101 031 220 0150
②	0.2-0.52	M23-FC9G-0.52P	101 031 220 0550
③	0.75-1.0	M23-FC9G-1.0P	101 031 220 0850

coil stock



Note: 10kpcs/volume

Tools

Terminal stamping machir



Wire gauge	Designation	Order No.
	M23-XC9G-MJ	903 020 000 0548

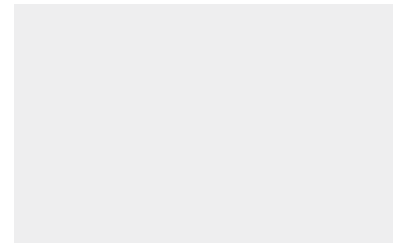
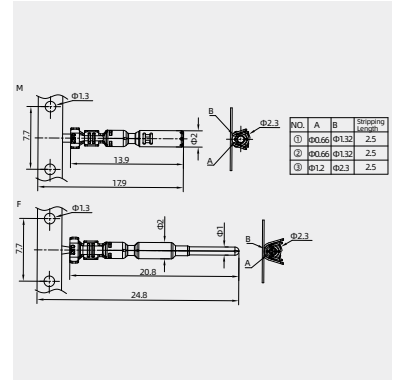

## MR23 Circular connector

160V- 10A

## Technical characteristics

Specifications			
Specifications	DIN EN 60 664		
	DIN EN 61 984		
Approvals			
Electrical data		Mechanical data	
Number of contacts	9 (8+1)	Housing material	copper alloy,zinc alloy
Rated current	10A	Housing surface	Nickel-plated
mm <sup>2</sup> / AWG	0.03-1.0+0.35-2.5	Contact resistance	≤ 5 mΩ
Rated voltage	160 V	Insulating bodies	PBT
Rated impulse voltage	2.5 kV	Contact material	copper alloy
Pollution degree	3	Contact surface	gold plated
Flammability acc. to UL 94	V0 (UL94)	Mechanical working life	>500
Overvoltage categorie	III	Degree of protection	IP67
		Limiting temperature	-40°C ...+130°C

Forward coding, Crimp terminal  
order crimp contacts separately

Contacts	Cable outlet	Designation	Order No.
9	4.5-8mm	MR23-009-CCT/R26-D8-SH	181 009 700 2524
	6-10mm	MR23-009-CCT/R26-D10-SH	181 009 700 2525
	9-14.5mm	MR23-009-CCT/R26-D14.5-SH	181 009 700 2526

Reverse coding, Crimp terminal  
order crimp contacts separately

Contacts	Cable outlet	Designation	Order No.
9	4.5-8mm	MR23-009R-CCT/R26-D8-SH	181 009 700 2527
	6-10mm	MR23-009R-CCT/R26-D10-SH	181 009 700 2528
	9-14.5mm	MR23-009R-CCT/R26-D14.5-SH	181 009 700 2529

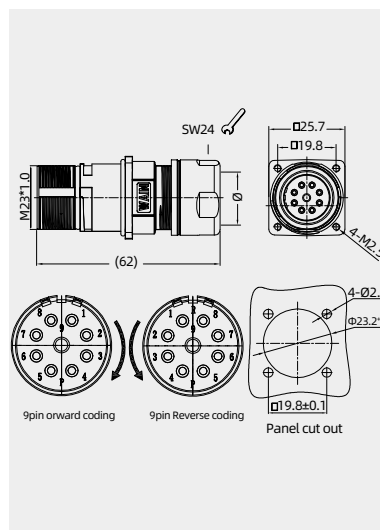

## Crimp contacts

## Crimp contacts 9A

9A



NO.	Wire gauge(mm <sup>2</sup> )	Male	Order No.
①	0.03-0.34	M23-MC9G-0.34	101 031 210 2501
②	0.14-1.0	M23-MC9G-1.0	101 031 210 0801

NO.	Wire gauge(mm <sup>2</sup> )	Female	Order No.
①	0.03-0.34	M23-FC9G-0.34	101 031 220 2501
②	0.14-1.0	M23-FC9G-1.0	101 031 220 0801

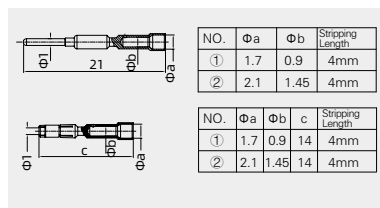

## Crimp contacts 20A

20A



NO.	Wire gauge(mm <sup>2</sup> )	Male	Order No.
①	0.35-2.5	MR23-MC20G-2.5	101 020 210 1001

NO.	Wire gauge(mm <sup>2</sup> )	Female	Order No.
①	0.35-2.5	MR23-FC20G-2.5	101 020 220 1001

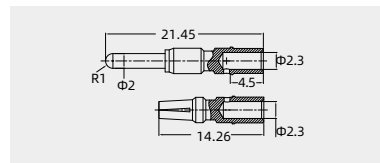

## Tools

## Crimping tool



Wire gauge	Designation	Order No.
0.14-4 mm <sup>2</sup>	TL28-2	198 001 001 0039

Notes: The tools for crimp terminal may influence the product quality and stability. Please select the tools recognized by our company.

Accessories

Stamped contacts

Stamped contacts



NO.	Wire gauge(mm <sup>2</sup> )	Male	Order No.
①	0.08-0.2	M23-MC9G-0.2P	101 031 210 0150
②	0.2-0.52	M23-MC9G-0.52P	101 031 210 0550
③	0.75-1.0	M23-MC9G-1.0P	101 031 210 0850
NO.	Wire gauge(mm <sup>2</sup> )	Female	Order No.
①	0.08-0.2	M23-FC9G-0.2P	101 031 220 0150
②	0.2-0.52	M23-FC9G-0.52P	101 031 220 0550
③	0.75-1.0	M23-FC9G-1.0P	101 031 220 0850

coil stock



Note: 10kpcs/volume

Tools

Terminal stamping machir



Wire gauge	Designation	Order No.
	M23-XC9G-MJ	903 020 000 0548

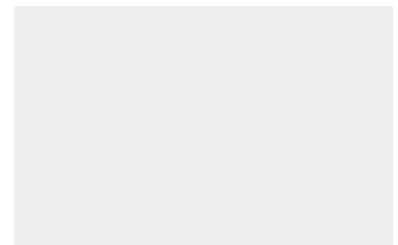
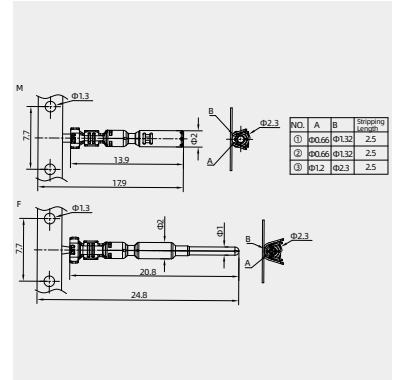

## MR23 Circular connector

160V- 10A

## Technical characteristics

Specifications			
Specifications	DIN EN 60 664		
	DIN EN 61 984		
Approvals			
Electrical data		Mechanical data	
Number of contacts	9	Housing material	copper alloy, zinc alloy
Rated current	10A	Housing surface	Nickel-plated
mm <sup>2</sup> / AWG	0.03-1.0	Contact resistance	≤ 5 mΩ
Rated voltage	160 V	Insulating bodies	PBT
Rated impulse voltage	2.5 kV	Contact material	copper alloy
Pollution degree	3	Contact surface	gold plated
Flammability acc. to UL 94	V0 (UL94)	Mechanical working life	>500
Overvoltage categorie	III	Degree of protection	IP67
		Limiting temperature	-40°C ...+130°C

Forward coding, Crimp terminal  
order crimp contacts separately

Contacts	Cable outlet	Designation	Order No.
9	4.5-8mm	MR23-009/B-CCT/R26-D8-SH	181 009 700 2530
	6-10mm	MR23-009/B-CCT/R26-D10-SH	181 009 700 2531
	9-14.5mm	MR23-009/B-CCT/R26-D14.5-SH	181 009 700 2532

Reverse coding, Crimp terminal  
order crimp contacts separately

Contacts	Cable outlet	Designation	Order No.
9	4.5-8mm	MR23-009R/B-CCT/R26-D8-SH	181 009 700 2533
	6-10mm	MR23-009R/B-CCT/R26-D10-SH	181 009 700 2534
	9-14.5mm	MR23-009R/B-CCT/R26-D14.5-SH	181 009 700 2535

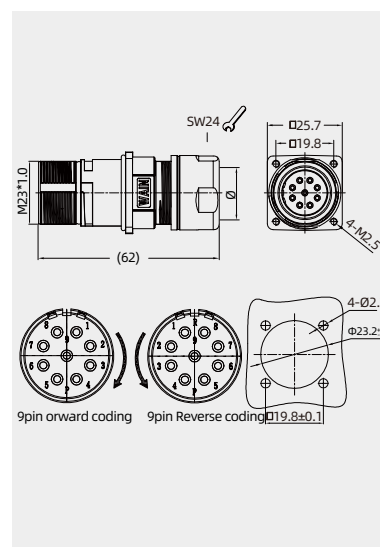
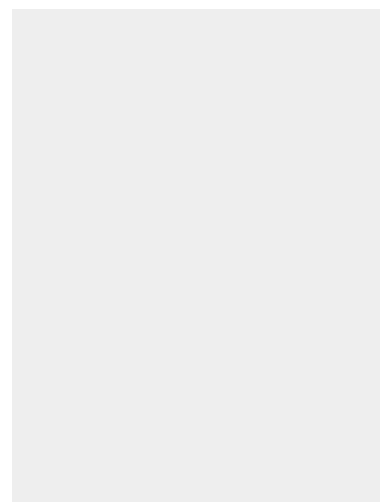

## Crimp contacts

## Crimp contacts 9A

9A



NO.	Wire gauge(mm <sup>2</sup> )	Male	Order No.
①	0.03-0.34	M23-MC9G-0.34	101 031 210 2501
②	0.14-1.0	M23-MC9G-1.0	101 031 210 0801
NO.	Wire gauge(mm <sup>2</sup> )	Female	Order No.
①	0.03-0.34	M23-FC9G-0.34	101 031 220 2501
②	0.14-1.0	M23-FC9G-1.0	101 031 220 0801

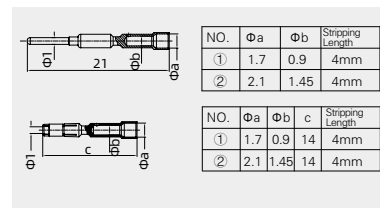

## Tools

## Crimping tool



Wire gauge	Designation	Order No.
0.14-4 mm <sup>2</sup>	TL28-2	198 001 001 0039

Notes: The tools for crimp terminal may influence the product quality and stability. Please select the tools recognized by our company.

Accessories

Stamped contacts

Stamped contacts



NO.	Wire gauge(mm <sup>2</sup> )	Male	Order No.
①	0.08-0.2	M23-MC9G-0.2P	101 031 210 0150
②	0.2-0.52	M23-MC9G-0.52P	101 031 210 0550
③	0.75-1.0	M23-MC9G-1.0P	101 031 210 0850
NO.	Wire gauge(mm <sup>2</sup> )	Female	Order No.
①	0.08-0.2	M23-FC9G-0.2P	101 031 220 0150
②	0.2-0.52	M23-FC9G-0.52P	101 031 220 0550
③	0.75-1.0	M23-FC9G-1.0P	101 031 220 0850

coil stock



Note: 10kpcs/volume

Tools

Terminal stamping machin



Wire gauge	Designation	Order No.
	M23-XC9G-MJ	903 020 000 0548

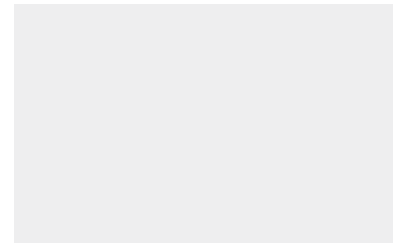
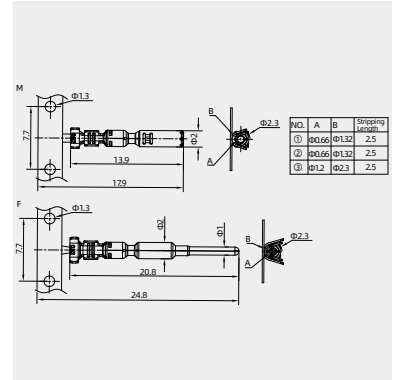



## MR23 Circular connector

160V- 10A

## Technical characteristics

Specifications			
Specifications	DIN EN 60 664		
	DIN EN 61 984		
Approvals			
Electrical data		Mechanical data	
Number of contacts	9 (8+1)	Housing material	copper alloy, zinc alloy
Rated current	10A	Housing surface	Nickel-plated
mm <sup>2</sup> / AWG	0.03-1.0+0.35-2.5	Contact resistance	≤ 5 mΩ
Rated voltage	160 V	Insulating bodies	PBT
Rated impulse voltage	2.5 kV	Contact material	copper alloy
Pollution degree	3	Contact surface	gold plated
Flammability acc. to UL 94	V0 (UL94)	Mechanical working life	>500
Overvoltage categorie	III	Degree of protection	IP67
		Limiting temperature	-40°C ...+130°C

Forward coding, Crimp terminal  
order crimp contacts separately

Contacts	Cable outlet	Designation	Order No.
9	4.5-8mm	MR23-009-CCT/R28-D8-SH	181 009 700 2536
	6-10mm	MR23-009-CCT/R28-D10-SH	181 009 700 2537
	9-14.5mm	MR23-009-CCT/R28-D14.5-SH	181 009 700 2538

Reverse coding, Crimp terminal  
order crimp contacts separately

Contacts	Cable outlet	Designation	Order No.
9	4.5-8mm	MR23-009R-CCT/R28-D8-SH	181 009 700 2539
	6-10mm	MR23-009R-CCT/R28-D10-SH	181 009 700 2540
	9-14.5mm	MR23-009R-CCT/R28-D14.5-SH	181 009 700 2541

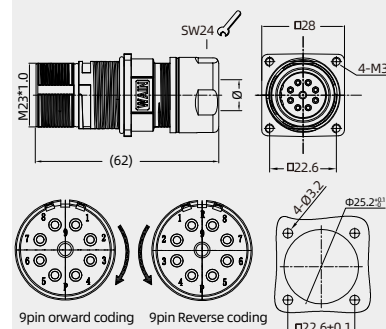

## Crimp contacts

## Crimp contacts 9A

9A



NO.	Wire gauge(mm <sup>2</sup> )	Male	Order No.
①	0.03-0.34	M23-MC9G-0.34	101 031 210 2501
②	0.14-1.0	M23-MC9G-1.0	101 031 210 0801

NO.	Wire gauge(mm <sup>2</sup> )	Female	Order No.
①	0.03-0.34	M23-FC9G-0.34	101 031 220 2501
②	0.14-1.0	M23-FC9G-1.0	101 031 220 0801

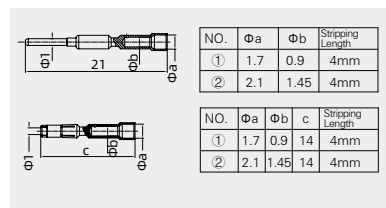

## Crimp contacts 20A

20A



NO.	Wire gauge(mm <sup>2</sup> )	Male	Order No.
①	0.35-2.5	MR23-MC20G-2.5	101 020 210 1001

NO.	Wire gauge(mm <sup>2</sup> )	Female	Order No.
①	0.35-2.5	MR23-FC20G-2.5	101 020 220 1001

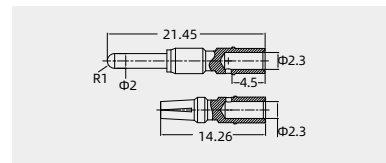

## Tools

## Crimping tool



Wire gauge	Designation	Order No.
0.14-4 mm <sup>2</sup>	TL28-2	198 001 001 0039

Notes: The tools for crimp terminal may influence the product quality and stability. Please select the tools recognized by our company.

Accessories

Stamped contacts

Stamped contacts



NO.	Wire gauge(mm <sup>2</sup> )	Male	Order No.
①	0.08-0.2	M23-MC9G-0.2P	101 031 210 0150
②	0.2-0.52	M23-MC9G-0.52P	101 031 210 0550
③	0.75-1.0	M23-MC9G-1.0P	101 031 210 0850
NO.	Wire gauge(mm <sup>2</sup> )	Female	Order No.
①	0.08-0.2	M23-FC9G-0.2P	101 031 220 0150
②	0.2-0.52	M23-FC9G-0.52P	101 031 220 0550
③	0.75-1.0	M23-FC9G-1.0P	101 031 220 0850

coil stock



Note: 10kpcs/volume

Tools

Terminal stamping machin



Wire gauge	Designation	Order No.
	M23-XC9G-MJ	903 020 000 0548

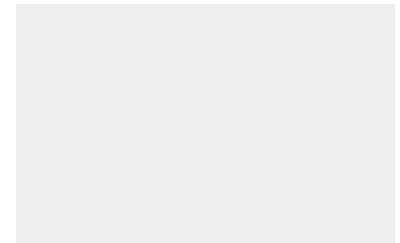
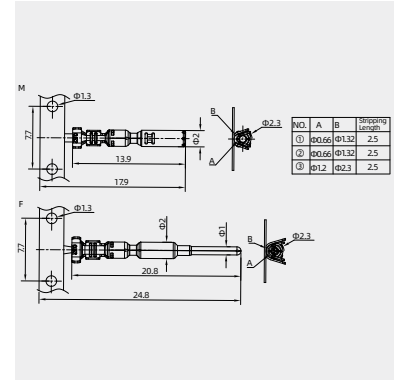

## MR23 Circular connector

160V- 10A

## Technical characteristics

Specifications			
Specifications	DIN EN 60 664		
	DIN EN 61 984		
Approvals			
Electrical data		Mechanical data	
Number of contacts	9	Housing material	copper alloy,zinc alloy
Rated current	10A	Housing surface	Nickel-plated
mm <sup>2</sup> / AWG	0.03-1.0	Contact resistance	≤ 5 mΩ
Rated voltage	160 V	Insulating bodies	PBT
Rated impulse voltage	2.5 kV	Contact material	copper alloy
Pollution degree	3	Contact surface	gold plated
Flammability acc. to UL 94	V0 (UL94)	Mechanical working life	>500
Overvoltage categorie	III	Degree of protection	IP67
		Limiting temperature	-40°C ...+130°C

Forward coding, Crimp terminal  
order crimp contacts separately

Contacts	Cable outlet	Designation	Order No.
9	4.5-8mm	MR23-009/B-CCT/R28-D8-SH	181 009 700 2542
	6-10mm	MR23-009/B-CCT/R28-D10-SH	181 009 700 2543
	9-14.5mm	MR23-009/B-CCT/R28-D14.5-SH	181 009 700 2544

Reverse coding, Crimp terminal  
order crimp contacts separately

Contacts	Cable outlet	Designation	Order No.
9	4.5-8mm	MR23-009R/B-CCT/R28-D8-SH	181 009 700 2545
	6-10mm	MR23-009R/B-CCT/R28-D10-SH	181 009 700 2546
	9-14.5mm	MR23-009R/B-CCT/R28-D14.5-SH	181 009 700 2547

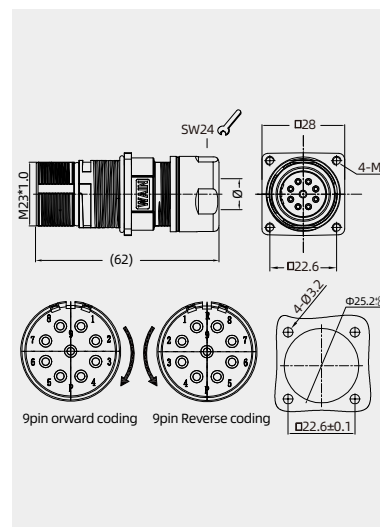
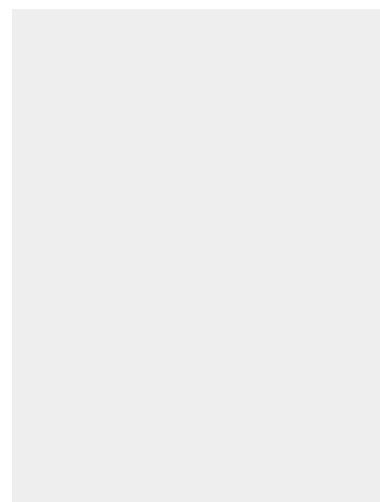

## Crimp contacts

## Crimp contacts 9A

9A



NO.	Wire gauge(mm <sup>2</sup> )	Male	Order No.
①	0.03-0.34	M23-MC9G-0.34	101 031 210 2501
②	0.14-1.0	M23-MC9G-1.0	101 031 210 0801
NO.	Wire gauge(mm <sup>2</sup> )	Female	Order No.
①	0.03-0.34	M23-FC9G-0.34	101 031 220 2501
②	0.14-1.0	M23-FC9G-1.0	101 031 220 0801

NO.	Φa	Φb	Stripping Length
①	1.7	0.9	4mm
②	2.1	1.45	4mm

NO.	Φa	Φb	c	Stripping Length
①	1.7	0.9	14	4mm
②	2.1	1.45	14	4mm

## Tools

## Crimping tool



Wire gauge	Designation	Order No.
0.14-4 mm <sup>2</sup>	TL28-2	198 001 001 0039

Notes: The tools for crimp terminal may influence the product quality and stability. Please select the tools recognized by our company.

Accessories

Stamped contacts

Stamped contacts



NO.	Wire gauge(mm <sup>2</sup> )	Male	Order No.
①	0.08-0.2	M23-MC9G-0.2P	101 031 210 0150
②	0.2-0.52	M23-MC9G-0.52P	101 031 210 0550
③	0.75-1.0	M23-MC9G-1.0P	101 031 210 0850
NO.	Wire gauge(mm <sup>2</sup> )	Female	Order No.
①	0.08-0.2	M23-FC9G-0.2P	101 031 220 0150
②	0.2-0.52	M23-FC9G-0.52P	101 031 220 0550
③	0.75-1.0	M23-FC9G-1.0P	101 031 220 0850

coil stock



Note: 10kpcs/volume

Tools

Terminal stamping machin



Wire gauge	Designation	Order No.
	M23-XC9G-MJ	903 020 000 0548

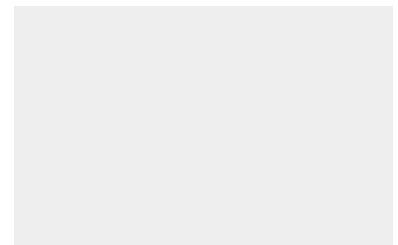
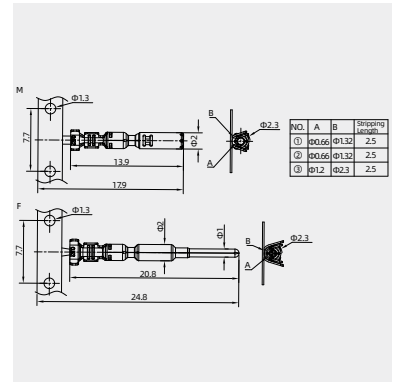

## MR23 Circular connector

300V- 20A

## Technical characteristics

Specifications			
Specifications	DIN EN 60 664		
	DIN EN 61 984		
Approvals			
Electrical data		Mechanical data	
Number of contacts	6	7	Housing material
Rated current	20A	20A	Housing surface
mm <sup>2</sup> / AWG	(0.35-2.5 mm <sup>2</sup> / AWG 22-14)		Contact resistance
Rated voltage	300 V	300 V	Insulating bodies
Rated impulse voltage	2.5 kV	2.5 kV	Contact material
Pollution degree	3	3	Contact surface
Flammability acc. to UL 94	V0 (UL94)	V0 (UL94)	Mechanical working life
Overvoltage categorie	III	III	Degree of protection
			Limiting temperature

Forward coding, Crimp terminal  
order crimp contacts separately

Contacts	Cable outlet	Designation	Order No.
6	4.5-8mm	MR23-006-CCT/R26-D8-SH	181 006 700 2013
	6-10mm	MR23-006-CCT/R26-D10-SH	181 006 700 2014
	9-14.5mm	MR23-006-CCT/R26-D14.5-SH	181 006 700 2015
7	4.5-8mm	MR23-007-CCT/R26-D8-SH	181 007 700 2013
	6-10mm	MR23-007-CCT/R26-D10-SH	181 007 700 2014
	9-14.5mm	MR23-007-CCT/R26-D14.5-SH	181 007 700 2015

Reverse coding, Crimp terminal  
order crimp contacts separately

Contacts	Cable outlet	Designation	Order No.
6	4.5-8mm	MR23-006R-CCT/R26-D8-SH	181 006 700 2016
	6-10mm	MR23-006R-CCT/R26-D10-SH	181 006 700 2017
	9-14.5mm	MR23-006R-CCT/R26-D14.5-SH	181 006 700 2018
7	4.5-8mm	MR23-007R-CCT/R26-D8-SH	181 007 700 2016
	6-10mm	MR23-007R-CCT/R26-D10-SH	181 007 700 2017
	9-14.5mm	MR23-007R-CCT/R26-D14.5-SH	181 007 700 2018

## Crimp contacts

## Crimp contacts 20A

20A



NO.	Wire gauge(mm <sup>2</sup> )	Male	Order No.
①	0.35-2.5	MR23-MC20G-2.5	101 020 210 1001
NO.	Wire gauge(mm <sup>2</sup> )	Female	Order No.
①	0.35-2.5	MR23-FC20G-2.5	101 020 220 1001

## Tools

## Crimping tool



Wire gauge	Designation	Order No.
0.14-4 mm <sup>2</sup>	TL28-2	198 001 001 0039

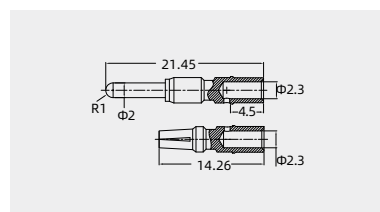
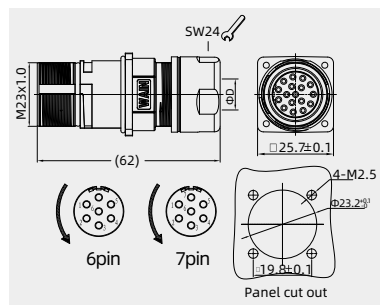
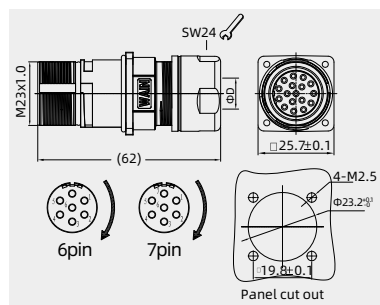
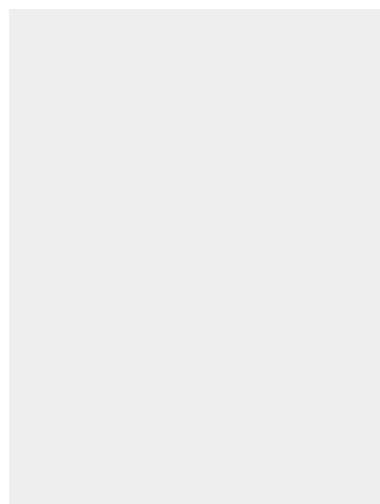

Notes: The tools for crimp terminal may influence the product quality and stability. Please select the tools recognized by our company.

## MR23 Circular connector

300V- 20A

## Technical characteristics

Specifications				
Specifications	DIN EN 60 664			
	DIN EN 61 984			
Approvals				
Electrical data		Mechanical data		
Number of contacts	6	7	Housing material	copper alloy,zinc alloy
Rated current	20A	20A	Housing surface	Nickel-plated
mm <sup>2</sup> / AWG	(0.35-2.5 mm <sup>2</sup> / AWG 22-14)		Contact resistance	≤ 5 mΩ
Rated voltage	300 V	300 V	Insulating bodies	PBT
Rated impulse voltage	2.5 kV	2.5 kV	Contact material	copper alloy
Pollution degree	3	3	Contact surface	gold plated
Flammability acc. to UL 94	V0 (UL94)	V0 (UL94)	Mechanical working life	>500
Overvoltage categorie	III	III	Degree of protection	IP67
			Limiting temperature	-40°C ...+130°C

Forward coding, Crimp terminal  
order crimp contacts separately

Contacts	Cable outlet	Designation	Order No.
6	4.5-8mm	MR23-006-CCT/R28-D8-SH	181 006 700 2019
	6-10mm	MR23-006-CCT/R28-D10-SH	181 006 700 2020
	9-14.5mm	MR23-006-CCT/R28-D14.5-SH	181 006 700 2021
7	4.5-8mm	MR23-007-CCT/R28-D8-SH	181 007 700 2019
	6-10mm	MR23-007-CCT/R28-D10-SH	181 007 700 2020
	9-14.5mm	MR23-007-CCT/R28-D14.5-SH	181 007 700 2021

Reverse coding, Crimp terminal  
order crimp contacts separately

Contacts	Cable outlet	Designation	Order No.
6	4.5-8mm	MR23-006R-CCT/R28-D8-SH	181 006 700 2022
	6-10mm	MR23-006R-CCT/R28-D10-SH	181 006 700 2023
	9-14.5mm	MR23-006R-CCT/R28-D14.5-SH	181 006 700 2024
7	4.5-8mm	MR23-007R-CCT/R28-D8-SH	181 007 700 2022
	6-10mm	MR23-007R-CCT/R28-D10-SH	181 007 700 2023
	9-14.5mm	MR23-007R-CCT/R28-D14.5-SH	181 007 700 2024

## Crimp contacts

## Crimp contacts 20A

20A



NO.	Wire gauge(mm <sup>2</sup> )	Male	Order No.
①	0.35-2.5	MR23-MC20G-2.5	101 020 210 1001
NO.	Wire gauge(mm <sup>2</sup> )	Female	Order No.
①	0.35-2.5	MR23-FC20G-2.5	101 020 220 1001

## Tools

## Crimping tool



Wire gauge	Designation	Order No.
0.14-4 mm <sup>2</sup>	TL28-2	198 001 001 0039

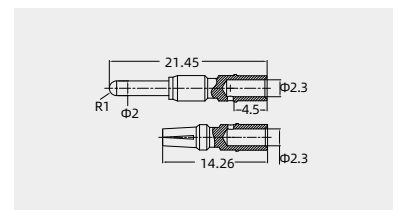
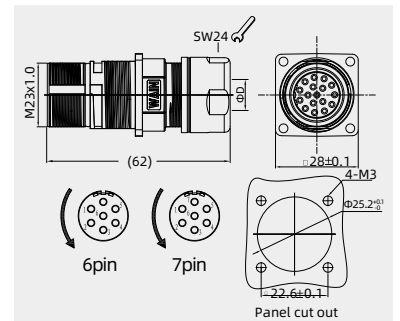
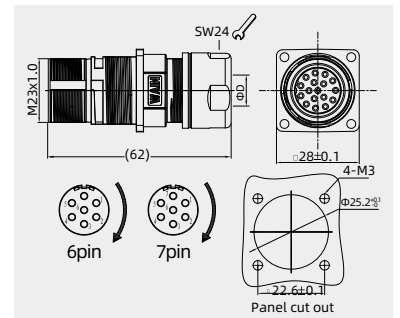
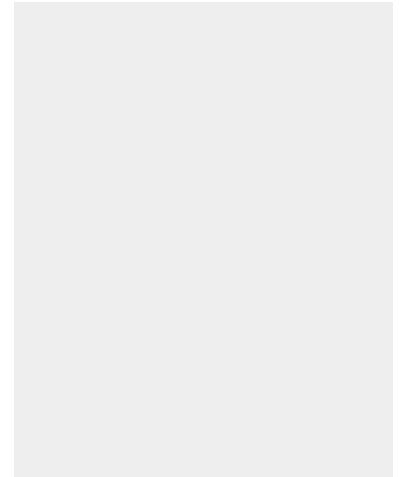

Notes: The tools for crimp terminal may influence the product quality and stability. Please select the tools recognized by our company.

## MR23 Circular connector

160V/125V- 7A

## Technical characteristics

Specifications				
Specifications	DIN EN 60 664			
	DIN EN 61 984			
Approvals				
Electrical data		Mechanical data		
Number of contacts	12	17	Housing material	copper alloy,zinc alloy
Rated current	7A	7A	Housing surface	Nickel-plated
mm <sup>2</sup> / AWG	(0.03-1.0 mm <sup>2</sup> / AWG 32-18)		Contact resistance	≤ 5 mΩ
Rated voltage	160 V	125 V	Insulating bodies	PBT
Rated impulse voltage	2.5 kV	2.0 kV	Contact material	copper alloy
Pollution degree	3	3	Contact surface	gold plated
Flammability acc. to UL 94	V0 (UL94)	V0 (UL94)	Mechanical working life	>500
Overvoltage categorie	III	III	Degree of protection	IP67
			Limiting temperature	-40°C ...+130°C

Forward coding, Crimp terminal  
order crimp contacts separately

Contacts	Cable outlet	Designation	Order No.
12	4.5-8mm	MR23-012-CCT-D8-SH	181 012 700 4004
	6-10mm	MR23-012-CCT-D10-SH	181 012 700 4005
	9-14.5mm	MR23-012-CCT-D14.5-SH	181 012 700 4007
17	4.5-8mm	MR23-017-CCT-D8-SH	181 017 700 2011
	6-10mm	MR23-017-CCT-D10-SH	181 017 400 2011
	9-14.5mm	MR23-017-CCT-D14.5-SH	181 017 421 2011

Reverse coding, Crimp terminal  
order crimp contacts separately

Contacts	Cable outlet	Designation	Order No.
12	4.5-8mm	MR23-012R-CCT-D8-SH	181 012 700 4008
	6-10mm	MR23-012R-CCT-D10-SH	181 012 421 2010
	9-14.5mm	MR23-012R-CCT-D14.5-SH	181 012 700 4009
17	4.5-8mm	MR23-017R-CCT-D8-SH	181 017 700 4004
	6-10mm	MR23-017R-CCT-D10-SH	181 017 700 2009
	9-14.5mm	MR23-017R-CCT-D14.5-SH	181 017 700 2010

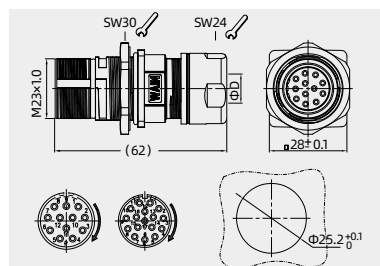
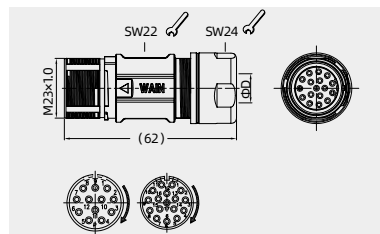
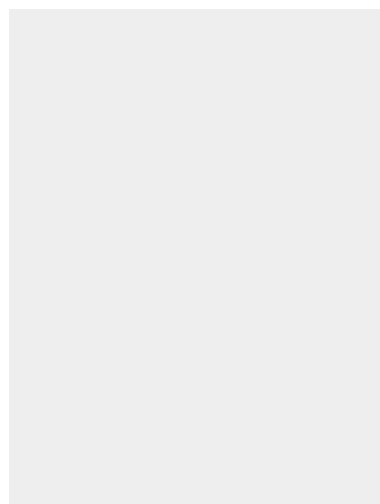

## Crimp contacts

## Crimp contacts 9A

9A



NO.	Wire gauge(mm <sup>2</sup> )	Male	Order No.
①	0.03-0.34	M23-MC9G-0.34	101 031 210 2501
②	0.14-1.0	M23-MC9G-1.0	101 031 210 0801
NO.	Wire gauge(mm <sup>2</sup> )	Female	Order No.
①	0.03-0.34	M23-FC9G-0.34	101 031 220 2501
②	0.14-1.0	M23-FC9G-1.0	101 031 220 0801

## Tools

Crimping tool



Wire gauge	Designation	Order No.
0.14-4 mm <sup>2</sup>	TL28-2	198 001 001 0039

NO.	Φa	Φb	Stripping Length
①	1.7	0.9	4mm
②	2.1	1.45	4mm

NO.	Φa	Φb	c	Stripping Length
①	1.7	0.9	14	4mm
②	2.1	1.45	14	4mm

Notes: The tools for crimp terminal may influence the product quality and stability. Please select the tools recognized by our company.

Accessories

Stamped contacts

Stamped contacts



NO.	Wire gauge(mm <sup>2</sup> )	Male	Order No.
①	0.08-0.2	M23-MC9G-0.2P	101 031 210 0150
②	0.2-0.52	M23-MC9G-0.52P	101 031 210 0550
③	0.75-1.0	M23-MC9G-1.0P	101 031 210 0850
NO.	Wire gauge(mm <sup>2</sup> )	Female	Order No.
①	0.08-0.2	M23-FC9G-0.2P	101 031 220 0150
②	0.2-0.52	M23-FC9G-0.52P	101 031 220 0550
③	0.75-1.0	M23-FC9G-1.0P	101 031 220 0850

coil stock



Note: 10kpcs/volume

Tools

Terminal stamping machir



Wire gauge	Designation	Order No.
	M23-XC9G-MJ	903 020 000 0548

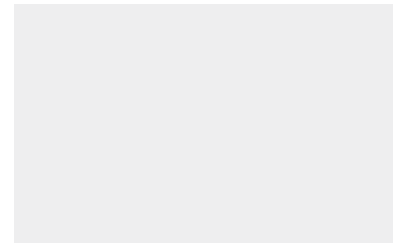
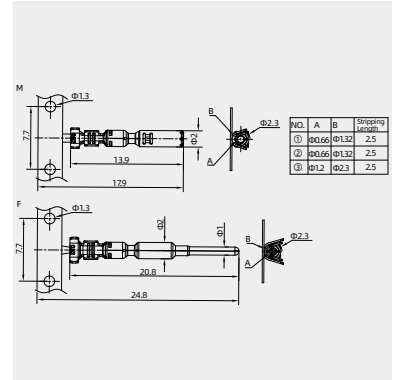



## MR23 Circular connector

160V/125V- 7A

## Technical characteristics

Specifications			
Specifications	DIN EN 60 664		
	DIN EN 61 984		
Approvals			
Electrical data		Mechanical data	
Number of contacts	12	17	Housing material
Rated current	7A	7A	Housing surface
mm <sup>2</sup> / AWG	(0.03-1.0 mm <sup>2</sup> / AWG 32-18)		Contact resistance
Rated voltage	160 V	125 V	Insulating bodies
Rated impulse voltage	2.5 kV	2.0 kV	Contact material
Pollution degree	3	3	Contact surface
Flammability acc. to UL 94	V0 (UL94)	V0 (UL94)	Mechanical working life
Overvoltage categorie	III	III	Degree of protection
			Limiting temperature

Forward coding, Crimp terminal  
order crimp contacts separately

Contacts	Cable outlet	Designation	Order No.
12	4.5-8mm	MR23-012-CCT/R-D8-SH	181 012 700 2008
	6-10mm	MR23-012-CCT/R-D10-SH	181 012 700 2007
	9-14.5mm	MR23-012-CCT/R-D14.5-SH	181 012 700 4011
17	4.5-8mm	MR23-017-CCT/R-D8-SH	181 017 700 2008
	6-10mm	MR23-017-CCT/R-D10-SH	181 017 400 2014
	9-14.5mm	MR23-017-CCT/R-D14.5-SH	181 017 700 2007

Reverse coding, Crimp terminal  
order crimp contacts separately

Contacts	Cable outlet	Designation	Order No.
12	4.5-8mm	MR23-012R-CCT/R-D8-SH	181 012 700 2014
	6-10mm	MR23-012R-CCT/R-D10-SH	181 012 700 2012
	9-14.5mm	MR23-012R-CCT/R-D14.5-SH	181 012 700 2013
17	4.5-8mm	MR23-017R-CCT/R-D8-SH	181 017 700 2021
	6-10mm	MR23-017R-CCT/R-D10-SH	181 017 700 2019
	9-14.5mm	MR23-017R-CCT/R-D14.5-SH	181 017 700 2020

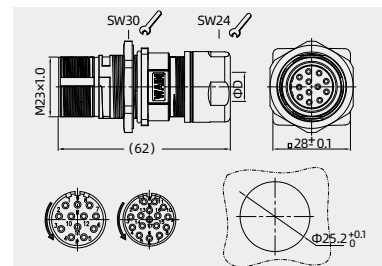
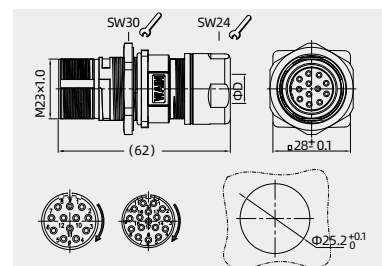
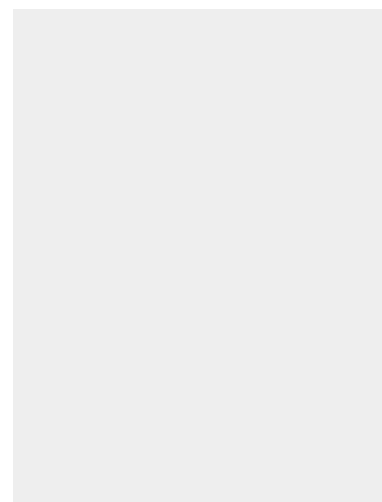

## Crimp contacts

## Crimp contacts 9A

9A



NO.	Wire gauge(mm <sup>2</sup> )	Male	Order No.
①	0.03-0.34	M23-MC9G-0.34	101 031 210 2501
②	0.14-1.0	M23-MC9G-1.0	101 031 210 0801
NO.	Wire gauge(mm <sup>2</sup> )	Female	Order No.
①	0.03-0.34	M23-FC9G-0.34	101 031 220 2501
②	0.14-1.0	M23-FC9G-1.0	101 031 220 0801

NO.	Φa	Φb	Stripping Length
①	1.7	0.9	4mm
②	2.1	1.45	4mm

NO.	Φa	Φb	c	Stripping Length
①	1.7	0.9	14	4mm
②	2.1	1.45	14	4mm

## Tools

## Crimping tool



Wire gauge	Designation	Order No.
0.14-4 mm <sup>2</sup>	TL28-2	198 001 001 0039

Notes: The tools for crimp terminal may influence the product quality and stability. Please select the tools recognized by our company.

Accessories

Stamped contacts

Stamped contacts



NO.	Wire gauge(mm <sup>2</sup> )	Male	Order No.
①	0.08-0.2	M23-MC9G-0.2P	101 031 210 0150
②	0.2-0.52	M23-MC9G-0.52P	101 031 210 0550
③	0.75-1.0	M23-MC9G-1.0P	101 031 210 0850
NO.	Wire gauge(mm <sup>2</sup> )	Female	Order No.
①	0.08-0.2	M23-FC9G-0.2P	101 031 220 0150
②	0.2-0.52	M23-FC9G-0.52P	101 031 220 0550
③	0.75-1.0	M23-FC9G-1.0P	101 031 220 0850

coil stock



Note: 10kpcs/volume

Tools

Terminal stamping machir



Wire gauge	Designation	Order No.
	M23-XC9G-MJ	903 020 000 0548

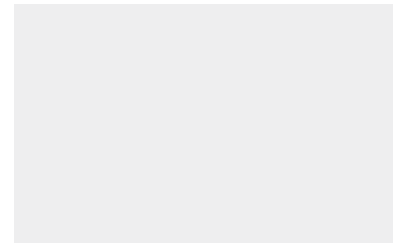
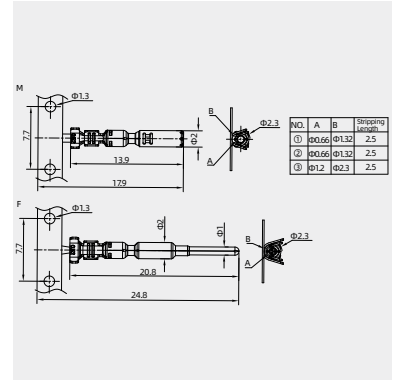

## MR23 Circular connector

160V/125V- 7A

## Technical characteristics

Specifications			
Specifications	DIN EN 60 664		
	DIN EN 61 984		
Approvals			
Electrical data		Mechanical data	
Number of contacts	12	17	Housing material
Rated current	7A	7A	Housing surface
mm <sup>2</sup> / AWG	(0.03-1.0 mm <sup>2</sup> / AWG 32-18)		Contact resistance
Rated voltage	160 V	125 V	Insulating bodies
Rated impulse voltage	2.5 kV	2.0 kV	Contact material
Pollution degree	3	3	Contact surface
Flammability acc. to UL 94	V0 (UL94)	V0 (UL94)	Mechanical working life
Overvoltage categorie	III	III	Degree of protection
			Limiting temperature

Forward coding, Crimp terminal  
order crimp contacts separately

Contacts	Cable outlet	Designation	Order No.
12	4.5-8mm	MR23-012-CCT/R26-D8-SH	181 012 700 2003
	6-10mm	MR23-012-CCT/R26-D10-SH	181 012 700 2001
	9-14.5mm	MR23-012-CCT/R26-D14.5-SH	181 012 700 2002
17	4.5-8mm	MR23-017-CCT/R26-D8-SH	181 017 700 2003
	6-10mm	MR23-017-CCT/R26-D10-SH	181 017 700 2001
	9-14.5mm	MR23-017-CCT/R26-D14.5-SH	181 017 700 2002

Reverse coding, Crimp terminal  
order crimp contacts separately

Contacts	Cable outlet	Designation	Order No.
12	4.5-8mm	MR23-012R-CCT/R26-D8-SH	181 012 700 2011
	6-10mm	MR23-012R-CCT/R26-D10-SH	181 012 700 2009
	9-14.5mm	MR23-012R-CCT/R26-D14.5-SH	181 012 700 2010
17	4.5-8mm	MR23-017R-CCT/R26-D8-SH	181 017 700 2015
	6-10mm	MR23-017R-CCT/R26-D10-SH	181 017 700 2013
	9-14.5mm	MR23-017R-CCT/R26-D14.5-SH	181 017 700 2014

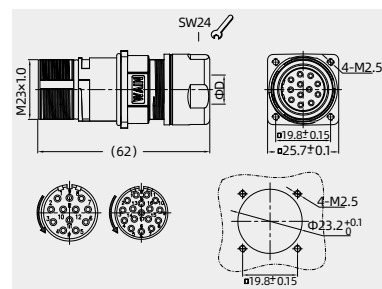
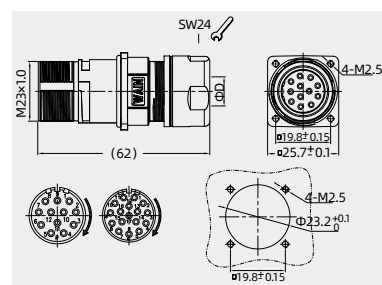
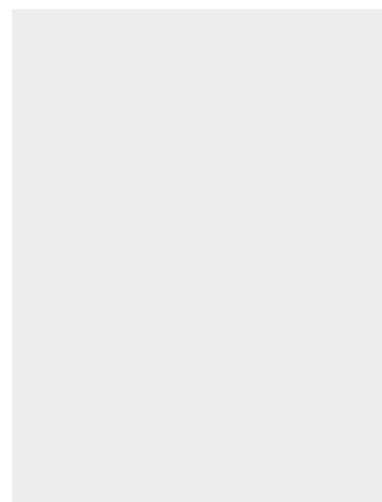

## Crimp contacts

## Crimp contacts 9A

9A



NO.	Wire gauge(mm <sup>2</sup> )	Male	Order No.
①	0.03-0.34	M23-MC9G-0.34	101 031 210 2501
②	0.14-1.0	M23-MC9G-1.0	101 031 210 0801
NO.	Wire gauge(mm <sup>2</sup> )	Female	Order No.
①	0.03-0.34	M23-FC9G-0.34	101 031 220 2501
②	0.14-1.0	M23-FC9G-1.0	101 031 220 0801

## Tools

## Crimping tool



Wire gauge	Designation	Order No.
0.14-4 mm <sup>2</sup>	TL28-2	198 001 001 0039

NO.	Φa	Φb	Stripping Length
①	1.7	0.9	4mm
②	2.1	1.45	4mm

NO.	Φa	Φb	c	Stripping Length
①	1.7	0.9	14	4mm
②	2.1	1.45	14	4mm

Notes: The tools for crimp terminal may influence the product quality and stability. Please select the tools recognized by our company.

Accessories

Stamped contacts

Stamped contacts



coil stock



Note: 10kpcs/volume

Tools

Terminal stamping machir



NO.	Wire gauge(mm <sup>2</sup> )	Male	Order No.
①	0.08-0.2	M23-MC9G-0.2P	101 031 210 0150
②	0.2-0.52	M23-MC9G-0.52P	101 031 210 0550
③	0.75-1.0	M23-MC9G-1.0P	101 031 210 0850
NO.	Wire gauge(mm <sup>2</sup> )	Female	Order No.
①	0.08-0.2	M23-FC9G-0.2P	101 031 220 0150
②	0.2-0.52	M23-FC9G-0.52P	101 031 220 0550
③	0.75-1.0	M23-FC9G-1.0P	101 031 220 0850

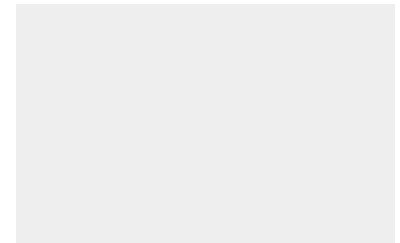
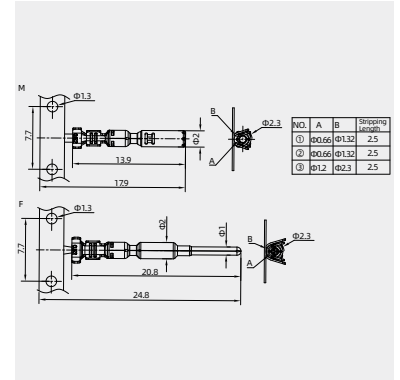

## MR23 Circular connector

160V/125V- 7A

## Technical characteristics

Specifications			
Specifications	DIN EN 60 664		
	DIN EN 61 984		
Approvals			
Electrical data		Mechanical data	
Number of contacts	12	17	Housing material
Rated current	7A	7A	Housing surface
mm <sup>2</sup> / AWG	(0.03-1.0 mm <sup>2</sup> / AWG 32-18)		Contact resistance
Rated voltage	160 V	125 V	Insulating bodies
Rated impulse voltage	2.5 kV	2.0 kV	Contact material
Pollution degree	3	3	Contact surface
Flammability acc. to UL 94	V0 (UL94)	V0 (UL94)	Mechanical working life
Overvoltage categorie	III	III	Degree of protection
			Limiting temperature

Forward coding, Crimp terminal  
order crimp contacts separately

Contacts	Cable outlet	Designation	Order No.
12	4.5-8mm	MR23-012-CCT/R28-D8-SH	181 012 700 2006
	6-10mm	MR23-012-CCT/R28-D10-SH	181 012 700 2004
	9-14.5mm	MR23-012-CCT/R28-D14.5-SH	181 012 700 2005
17	4.5-8mm	MR23-017-CCT/R28-D8-SH	181 017 700 2006
	6-10mm	MR23-017-CCT/R28-D10-SH	181 017 700 2004
	9-14.5mm	MR23-017-CCT/R28-D14.5-SH	181 017 700 2005

Reverse coding, Crimp terminal  
order crimp contacts separately

Contacts	Cable outlet	Designation	Order No.
12	4.5-8mm	MR23-012R-CCT/R28-D8-SH	181 012 799 2010
	6-10mm	MR23-012R-CCT/R28-D10-SH	181 012 799 2011
	9-14.5mm	MR23-012R-CCT/R28-D14.5-SH	181 012 799 2012
17	4.5-8mm	MR23-017R-CCT/R28-D8-SH	181 017 700 2018
	6-10mm	MR23-017R-CCT/R28-D10-SH	181 017 700 2016
	9-14.5mm	MR23-017R-CCT/R28-D14.5-SH	181 017 700 2017

## Crimp contacts

## Crimp contacts 9A

9A



NO.	Wire gauge(mm <sup>2</sup> )	Male	Order No.
①	0.03-0.34	M23-MC9G-0.34	101 031 210 2501
②	0.14-1.0	M23-MC9G-1.0	101 031 210 0801
NO.	Wire gauge(mm <sup>2</sup> )	Female	Order No.
①	0.03-0.34	M23-FC9G-0.34	101 031 220 2501
②	0.14-1.0	M23-FC9G-1.0	101 031 220 0801

## Tools

## Crimping tool



Wire gauge	Designation	Order No.
0.14-4 mm <sup>2</sup>	TL28-2	198 001 001 0039

Notes: The tools for crimp terminal may influence the product quality and stability. Please select the tools recognized by our company.

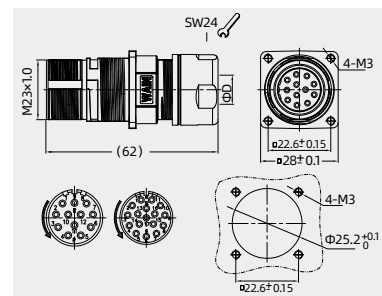
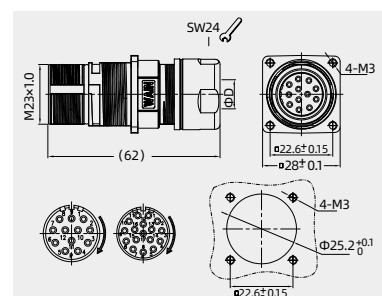
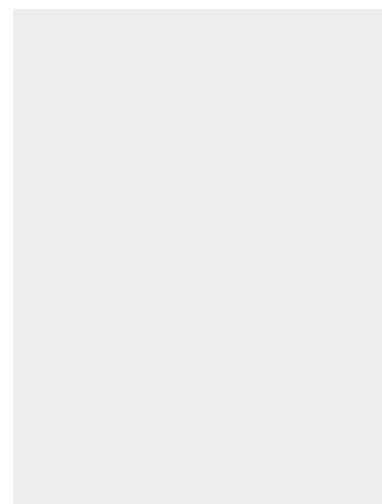

NO.	Φa	Φb	Stripping Length
①	1.7	0.9	4mm
②	2.1	1.45	4mm

NO.	Φa	Φb	c	Stripping Length
①	1.7	0.9	14	4mm
②	2.1	1.45	14	4mm

Accessories

Stamped contacts

Stamped contacts



NO.	Wire gauge(mm <sup>2</sup> )	Male	Order No.
①	0.08-0.2	M23-MC9G-0.2P	101 031 210 0150
②	0.2-0.52	M23-MC9G-0.52P	101 031 210 0550
③	0.75-1.0	M23-MC9G-1.0P	101 031 210 0850
NO.	Wire gauge(mm <sup>2</sup> )	Female	Order No.
①	0.08-0.2	M23-FC9G-0.2P	101 031 220 0150
②	0.2-0.52	M23-FC9G-0.52P	101 031 220 0550
③	0.75-1.0	M23-FC9G-1.0P	101 031 220 0850

coil stock



Note: 10kpcs/volume

Tools

Terminal stamping machin



Wire gauge	Designation	Order No.
	M23-XC9G-MJ	903 020 000 0548

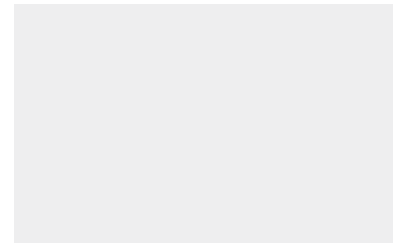
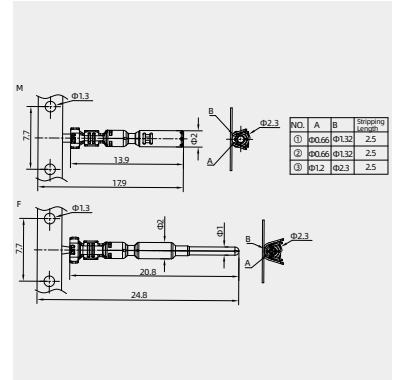

## MR23 Circular connector

63V- 7A

## Technical characteristics

Specifications		Mechanical data	
Specifications	DIN EN 60 664 DIN EN 61 984	Housing material	copper alloy,zinc alloy
Approvals			
Electrical data		Housing surface	Nickel-plated
Number of contacts	19(16+3)	Contact resistance	≤ 5 mΩ
signal:	0.03-1.0 mm <sup>2</sup> / AWG 32-18	Insulating bodies	PBT
power:	0.14-1.5 mm <sup>2</sup> / AWG 20-16	Contact material	copper alloy
Rated current	7A	Contact surface	gold plated
Rated voltage	63 V	Mechanical working life	>500
Rated impulse voltage	1.5 kV	Degree of protection	IP67
Pollution degree	3	Limiting temperature	-40°C ...+130°C
Flammability acc. to UL 94	V0 (UL94)		
Overvoltage categorie	III		

Forward coding, Crimp terminal  
order crimp contacts separately

Contacts	Cable outlet	Designation	Order No.
19	4.5-8mm	MR23-019-CCT-D8-SH	181 019 700 2001
	6-10mm	MR23-019-CCT-D10-SH	181 019 700 2002
	9-14.5mm	MR23-019-CCT-D14.5-SH	181 019 700 2003

Reverse coding, Crimp terminal  
order crimp contacts separately

Contacts	Cable outlet	Designation	Order No.
19	4.5-8mm	MR23-019R-CCT-D8-SH	181 019 700 2004
	6-10mm	MR23-019R-CCT-D10-SH	181 019 700 2005
	9-14.5mm	MR23-019R-CCT-D14.5-SH	181 019 700 2006

## Crimp contacts

## Crimp contacts 9A/7A

9A(signal)



7A(power)



9A(signal)



7A(power)



NO.	Wire gauge(mm <sup>2</sup> )	Male	Order No.
①	0.03-0.34	M23-MC9G-0.34	101 031 210 2501
②	0.14-1.0	M23-MC9G-1.0	101 031 210 0801
③	0.14-1.4	MR23-MC7G-1.0	101 015 210 0801
④	0.5-1.5	MR23-MC7G-1.5	101 015 210 0901
NO.	Wire gauge(mm <sup>2</sup> )	Female	Order No.
①	0.03-0.34	M23-FC9G-0.34	101 031 220 2501
②	0.14-1.0	M23-FC9G-1.0	101 031 220 0801
③	0.14-1.4	MR23-FC7G-1.0	101 015 220 0801
④	0.5-1.5	MR23-FC7G-1.5	101 015 220 0901

## Tools

Crimping tool



Wire gauge	Designation	Order No.
0.14-4 mm <sup>2</sup>	TL28-2	198 001 001 0039

Notes: The tools for crimp terminal may influence the product quality and stability. Please select the tools recognized by our company.

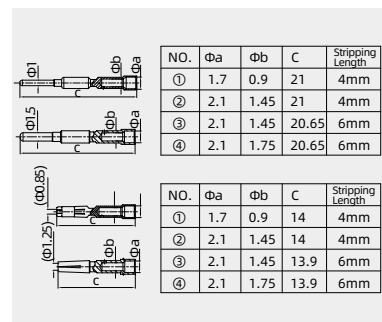
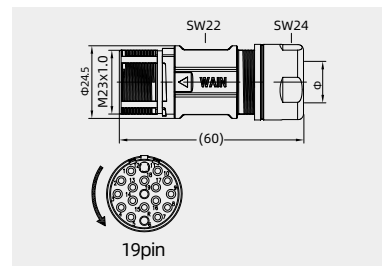
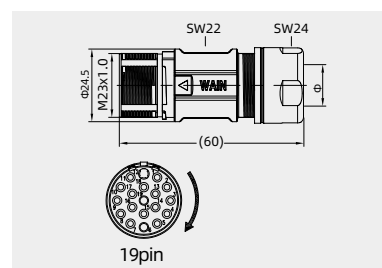
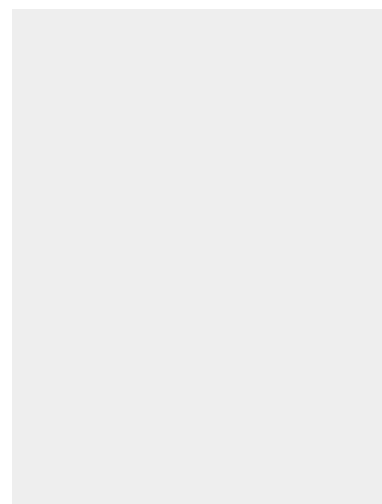

Accessories

Stamped contacts

Stamped contacts



NO.	Wire gauge(mm <sup>2</sup> )	Male	Order No.
①	0.08-0.2	M23-MC9G-0.2P	101 031 210 0150
②	0.2-0.52	M23-MC9G-0.52P	101 031 210 0550
③	0.75-1.0	M23-MC9G-1.0P	101 031 210 0850
NO.	Wire gauge(mm <sup>2</sup> )	Female	Order No.
①	0.08-0.2	M23-FC9G-0.2P	101 031 220 0150
②	0.2-0.52	M23-FC9G-0.52P	101 031 220 0550
③	0.75-1.0	M23-FC9G-1.0P	101 031 220 0850

coil stock



Note: 10kpcs/volume

Tools

Terminal stamping machir



Wire gauge	Designation	Order No.
	M23-XC9G-MJ	903 020 000 0548

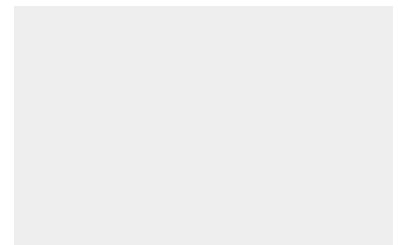
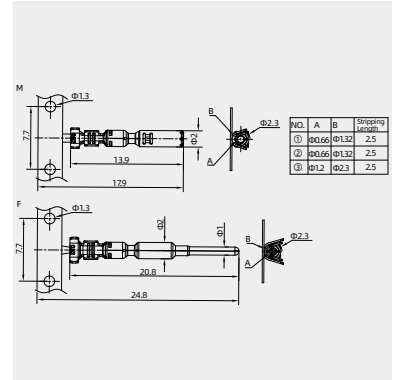



## MR23 Circular connector

63V- 7A

## Technical characteristics

Specifications			
Specifications	DIN EN 60 664 DIN EN 61 984		
Approvals			
Electrical data	Mechanical data		
Number of contacts	19(16+3)	Housing material	copper alloy,zinc alloy
signal:	0.03-1.0 mm <sup>2</sup> / AWG 32-18	Housing surface	Nickel-plated
power:	0.14-1.5 mm <sup>2</sup> / AWG 20-16	Contact resistance	≤ 5 mΩ
Rated current	7A	Insulating bodies	PBT
Rated voltage	63 V	Contact material	copper alloy
Rated impulse voltage	1.5 kV	Contact surface	gold plated
Pollution degree	3	Mechanical working life	>500
Flammability acc. to UL 94	V0 (UL94)	Degree of protection	IP67
Overvoltage categorie	III	Limiting temperature	-40°C ...+130°C

Forward coding, Crimp terminal  
order crimp contacts separately

Contacts	Cable outlet	Designation	Order No.
19	4.5-8mm	MR23-019-CCT/R-D8-SH	181 019 700 2007
	6-10mm	MR23-019-CCT/R-D10-SH	181 019 700 2008
	9-14.5mm	MR23-019-CCT/R-D14.5-SH	181 019 700 2009

Reverse coding, Crimp terminal  
order crimp contacts separately

Contacts	Cable outlet	Designation	Order No.
19	4.5-8mm	MR23-019R-CCT/R-D8-SH	181 019 700 2010
	6-10mm	MR23-019R-CCT/R-D10-SH	181 019 700 2011
	9-14.5mm	MR23-019R-CCT/R-D14.5-SH	181 019 700 2012

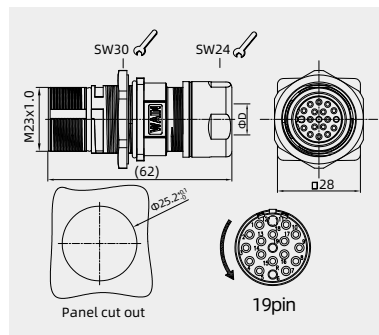
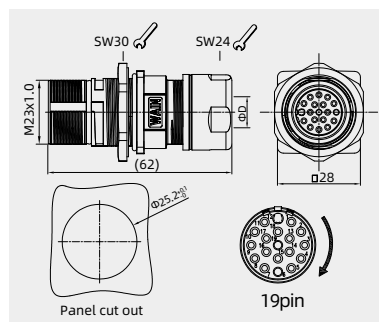
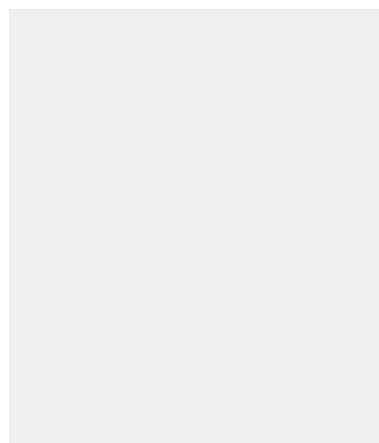

## Crimp contacts

## Crimp contacts 9A/7A

9A(signal)

7A(power)

9A(signal)

7A(power)

NO.	Wire gauge(mm <sup>2</sup> )	Male	Order No.
①	0.03-0.34	M23-MC9G-0.34	101 031 210 2501
②	0.14-1.0	M23-MC9G-1.0	101 031 210 0801
③	0.14-1.4	MR23-MC7G-1.0	101 015 210 0801
④	0.5-1.5	MR23-MC7G-1.5	101 015 210 0901
NO.	Wire gauge(mm <sup>2</sup> )	Female	Order No.
①	0.03-0.34	M23-FC9G-0.34	101 031 220 2501
②	0.14-1.0	M23-FC9G-1.0	101 031 220 0801
③	0.14-1.4	MR23-FC7G-1.0	101 015 220 0801
④	0.5-1.5	MR23-FC7G-1.5	101 015 220 0901

NO.	Φa	Φb	C	Stripping Length
①	1.7	0.9	21	4mm
②	2.1	1.45	21	4mm
③	2.1	1.45	20.65	6mm
④	2.1	1.75	20.65	6mm

NO.	Φa	Φb	C	Stripping Length
①	1.7	0.9	14	4mm
②	2.1	1.45	14	4mm
③	2.1	1.45	13.9	6mm
④	2.1	1.75	13.9	6mm

## Tools

Crimping tool

Wire gauge	Designation	Order No.
0.14-4 mm <sup>2</sup>	TL28-2	198 001 001 0039

Notes: The tools for crimp terminal may influence the product quality and stability. Please select the tools recognized by our company.

Accessories

Stamped contacts

Stamped contacts



coil stock



Note: 10kpcs/volume

Tools

Terminal stamping machin



NO.	Wire gauge(mm <sup>2</sup> )	Male	Order No.
①	0.08-0.2	M23-MC9G-0.2P	101 031 210 0150
②	0.2-0.52	M23-MC9G-0.52P	101 031 210 0550
③	0.75-1.0	M23-MC9G-1.0P	101 031 210 0850
NO.	Wire gauge(mm <sup>2</sup> )	Female	Order No.
①	0.08-0.2	M23-FC9G-0.2P	101 031 220 0150
②	0.2-0.52	M23-FC9G-0.52P	101 031 220 0550
③	0.75-1.0	M23-FC9G-1.0P	101 031 220 0850

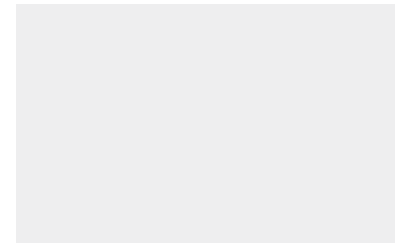
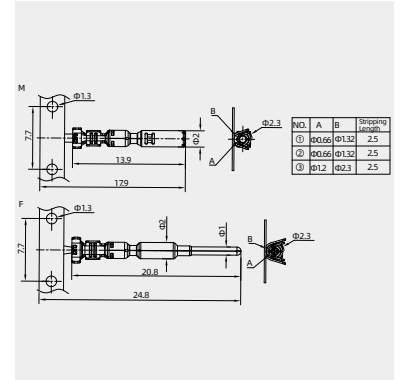

## MR23 Circular connector

63V- 7A

## Technical characteristics

Specifications			
Specifications	DIN EN 60 664		
	DIN EN 61 984		
Approvals			
Electrical data		Mechanical data	
Number of contacts	19(16+3)	Housing material	copper alloy,zinc alloy
signal:	0.03-1.0 mm <sup>2</sup> / AWG 32-18	Housing surface	Nickel-plated
power:	0.14-1.5 mm <sup>2</sup> / AWG 20-16	Contact resistance	≤ 5 mΩ
Rated current	7A	Insulating bodies	PBT
Rated voltage	63 V	Contact material	copper alloy
Rated impulse voltage	1.5 kV	Contact surface	gold plated
Pollution degree	3	Mechanical working life	>500
Flammability acc. to UL 94	V0 (UL94)	Degree of protection	IP67
Overvoltage categorie	III	Limiting temperature	-40°C ...+130°C

Forward coding, Crimp terminal  
order crimp contacts separately



Contacts	Cable outlet	Designation	Order No.
19	4.5-8mm	MR23-019-CCT/R26-D8-SH	181 019 700 2013
	6-10mm	MR23-019-CCT/R26-D10-SH	181 019 700 2014
	9-14.5mm	MR23-019-CCT/R26-D14.5-SH	181 019 700 2015

Reverse coding, Crimp terminal  
order crimp contacts separately



Contacts	Cable outlet	Designation	Order No.
19	4.5-8mm	MR23-019R-CCT/R26-D10-SH	181 019 700 2016
	6-10mm	MR23-019R-CCT/R26-D10-SH	181 019 700 2017
	9-14.5mm	MR23-019R-CCT/R26-D14.5-SH	181 019 700 2018

## Crimp contacts

Crimp contacts 9A/7A



NO.	Wire gauge(mm <sup>2</sup> )	Male	Order No.
①	0.03-0.34	M23-MC9G-0.34	101 031 210 2501
②	0.14-1.0	M23-MC9G-1.0	101 031 210 0801
③	0.14-1.4	MR23-MC7G-1.0	101 015 210 0801
④	0.5-1.5	MR23-MC7G-1.5	101 015 210 0901
NO.	Wire gauge(mm <sup>2</sup> )	Female	Order No.
①	0.03-0.34	M23-FC9G-0.34	101 031 220 2501
②	0.14-1.0	M23-FC9G-1.0	101 031 220 0801
③	0.14-1.4	MR23-FC7G-1.0	101 015 220 0801
④	0.5-1.5	MR23-FC7G-1.5	101 015 220 0901

Tools



Wire gauge	Designation	Order No.
0.14-4 mm <sup>2</sup>	TL28-2	198 001 001 0039

Notes: The tools for crimp terminal may influence the product quality and stability. Please select the tools recognized by our company.

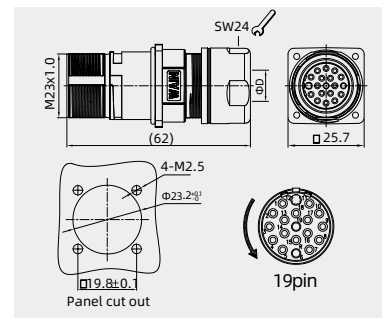
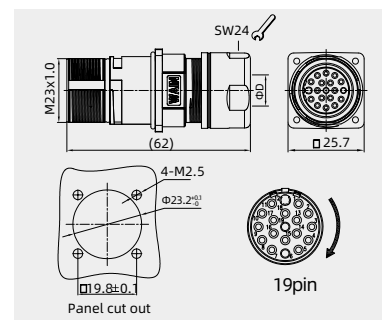
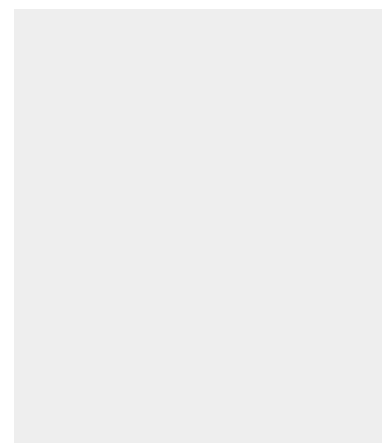

NO.	Φa	Φb	C	Stripping Length
①	1.7	0.9	21	4mm
②	2.1	1.45	21	4mm
③	2.1	1.45	20.65	6mm
④	2.1	1.75	20.65	6mm

NO.	Φa	Φb	C	Stripping Length
①	1.7	0.9	14	4mm
②	2.1	1.45	14	4mm
③	2.1	1.45	13.9	6mm
④	2.1	1.75	13.9	6mm

Accessories

Stamped contacts

Stamped contacts



coil stock



Note: 10kpcs/volume

NO.	Wire gauge(mm <sup>2</sup> )	Male	Order No.
①	0.08-0.2	M23-MC9G-0.2P	101 031 210 0150
②	0.2-0.52	M23-MC9G-0.52P	101 031 210 0550
③	0.75-1.0	M23-MC9G-1.0P	101 031 210 0850
NO.	Wire gauge(mm <sup>2</sup> )	Female	Order No.
①	0.08-0.2	M23-FC9G-0.2P	101 031 220 0150
②	0.2-0.52	M23-FC9G-0.52P	101 031 220 0550
③	0.75-1.0	M23-FC9G-1.0P	101 031 220 0850

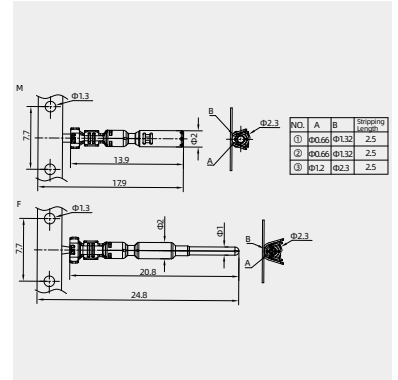

Tools

Terminal stamping machir



Wire gauge	Designation	Order No.
	M23-XC9G-MJ	903 020 000 0548

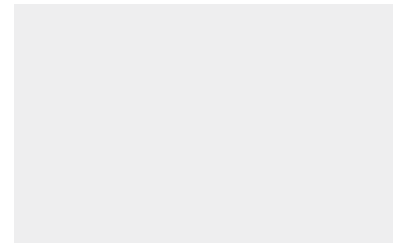

## MR23 Circular connector

63V- 7A

## Technical characteristics

Specifications			
Specifications	DIN EN 60 664		
	DIN EN 61 984		
Approvals			
Electrical data		Mechanical data	
Number of contacts	19(16+3)	Housing material	copper alloy,zinc alloy
signal:	0.03-1.0 mm <sup>2</sup> / AWG 32-18	Housing surface	Nickel-plated
power:	0.14-1.5 mm <sup>2</sup> / AWG 20-16	Contact resistance	≤ 5 mΩ
Rated current	7A	Insulating bodies	PBT
Rated voltage	63 V	Contact material	copper alloy
Rated impulse voltage	1.5 kv	Contact surface	gold plated
Pollution degree	3	Mechanical working life	>500
Flammability acc. to UL 94	V0 (UL94)	Degree of protection	IP67
Overvoltage categorie	III	Limiting temperature	-40°C ...+130°C

Forward coding, Crimp terminal  
order crimp contacts separately

Contacts	Cable outlet	Designation	Order No.
19	4.5-8mm	MR23-019-CCT/R28-D8-SH	181 019 700 2019
	6-10mm	MR23-019-CCT/R28-D10-SH	181 019 700 2020
	9-14.5mm	MR23-019-CCT/R28-D14.5-SH	181 019 700 2021

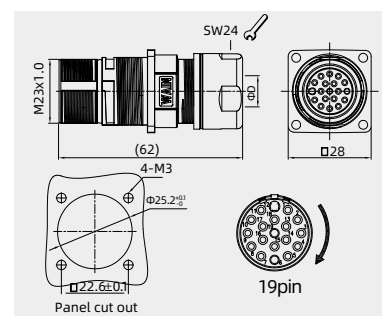
Reverse coding, Crimp terminal  
order crimp contacts separately

Contacts	Cable outlet	Designation	Order No.
19	4.5-8mm	MR23-019R-CCT/R28-D8-SH	181 019 700 2022
	6-10mm	MR23-019R-CCT/R28-D10-SH	181 019 700 2023
	9-14.5mm	MR23-019R-CCT/R28-D14.5-SH	181 019 700 2024

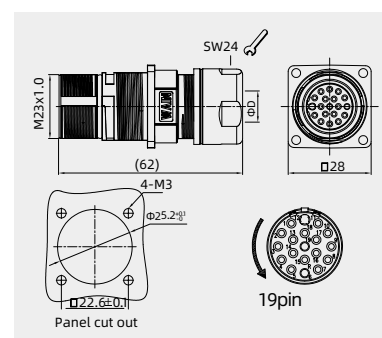

## Crimp contacts

## Crimp contacts 9A/7A

9A(signal)

7A(power)

9A(signal)

7A(power)

NO.	Wire gauge(mm <sup>2</sup> )	Male	Order No.
①	0.03-0.34	M23-MC9G-0.34	101 031 210 2501
②	0.14-1.0	M23-MC9G-1.0	101 031 210 0801
③	0.14-1.4	MR23-MC7G-1.0	101 015 210 0801
④	0.5-1.5	MR23-MC7G-1.5	101 015 210 0901
NO.	Wire gauge(mm <sup>2</sup> )	Female	Order No.
①	0.03-0.34	M23-FC9G-0.34	101 031 220 2501
②	0.14-1.0	M23-FC9G-1.0	101 031 220 0801
③	0.14-1.4	MR23-FC7G-1.0	101 015 220 0801
④	0.5-1.5	MR23-FC7G-1.5	101 015 220 0901

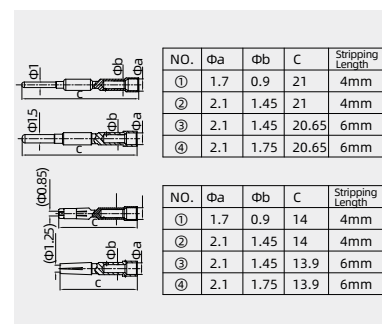

## Tools

Crimping tool

Wire gauge	Designation	Order No.
0.14-4 mm <sup>2</sup>	TL28-2	198 001 001 0039

Notes: The tools for crimp terminal may influence the product quality and stability. Please select the tools recognized by our company.

Accessories

Stamped contacts

Stamped contacts



coil stock



Note: 10kpcs/volume

Tools

Terminal stamping machir



NO.	Wire gauge(mm <sup>2</sup> )	Male	Order No.
①	0.08-0.2	M23-MC9G-0.2P	101 031 210 0150
②	0.2-0.52	M23-MC9G-0.52P	101 031 210 0550
③	0.75-1.0	M23-MC9G-1.0P	101 031 210 0850
NO.	Wire gauge(mm <sup>2</sup> )	Female	Order No.
①	0.08-0.2	M23-FC9G-0.2P	101 031 220 0150
②	0.2-0.52	M23-FC9G-0.52P	101 031 220 0550
③	0.75-1.0	M23-FC9G-1.0P	101 031 220 0850

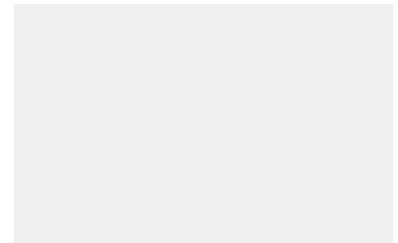
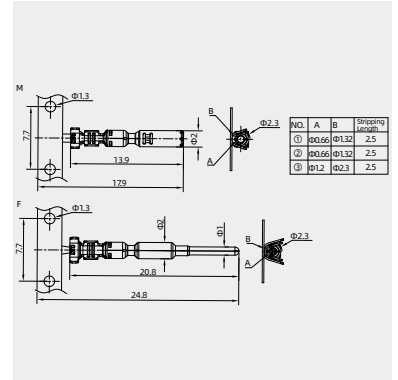

## MR23 Circular connector

300V- 20A

## Technical characteristics

Specifications				
Specifications	DIN EN 60 664			
	DIN EN 61 984			
Approvals				
Electrical data		Mechanical data		
Number of contacts	6	7	Housing material	copper alloy,zinc alloy
Rated current	20A	20A	Housing surface	Nickel-plated
mm <sup>2</sup> / AWG	(0.35-2.5 mm <sup>2</sup> / AWG 22-14)		Contact resistance	≤ 5 mΩ
Rated voltage	300 V	300 V	Insulating bodies	PBT
Rated impulse voltage	2.5 kV	2.5 kV	Contact material	copper alloy
Pollution degree	3	3	Contact surface	gold plated
Flammability acc. to UL 94	V0 (UL94)	V0 (UL94)	Mechanical working life	>500
Overvoltage categorie	III	III	Degree of protection	IP67
			Limiting temperature	-40°C ...+130°C

Forward coding, Crimp terminal  
order crimp contacts separately

Contacts	Cable outlet	Designation	Order No.
6	4.5-8mm	MR23-006-T-D8-SH	181 006 400 2001
	6-10mm	MR23-006-T-D10-SH	181 006 400 2002
	9-14.5mm	MR23-006-T-D14.5-SH	181 006 400 2003
7	4.5-8mm	MR23-007-T-D8-SH	181 007 400 2001
	6-10mm	MR23-007-T-D10-SH	181 007 400 2002
	9-14.5mm	MR23-007-T-D14.5-SH	181 007 400 2003

Reverse coding, Crimp terminal  
order crimp contacts separately

Contacts	Cable outlet	Designation	Order No.
6	4.5-8mm	MR23-006R-T-D8-SH	181 006 400 2004
	6-10mm	MR23-006R-T-D10-SH	181 006 400 2005
	9-14.5mm	MR23-006R-T-D14.5-SH	181 006 400 2006
7	4.5-8mm	MR23-007R-T-D8-SH	181 007 400 2004
	6-10mm	MR23-007R-T-D10-SH	181 007 400 2005
	9-14.5mm	MR23-007R-T-D14.5-SH	181 007 400 2006

## Crimp contacts

## Crimp contacts 20A

20A



NO.	Wire gauge(mm <sup>2</sup> )	Male	Order No.
①	0.35-2.5	MR23-MC20G-2.5	101 020 210 1001
NO.	Wire gauge(mm <sup>2</sup> )	Female	Order No.
①	0.35-2.5	MR23-FC20G-2.5	101 020 220 1001

## Tools

## Crimping tool



Wire gauge	Designation	Order No.
0.14-4 mm <sup>2</sup>	TL28-2	198 001 001 0039

Notes: The tools for crimp terminal may influence the product quality and stability. Please select the tools recognized by our company.

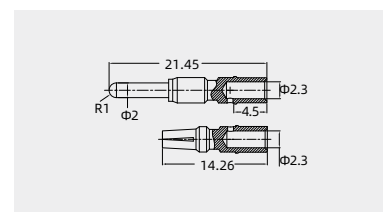
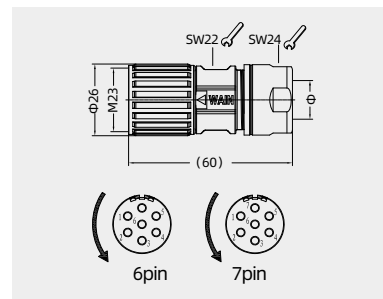
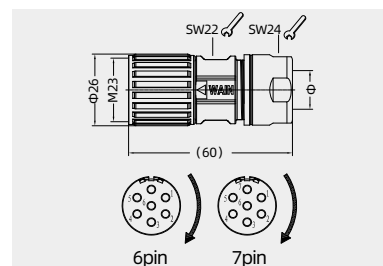
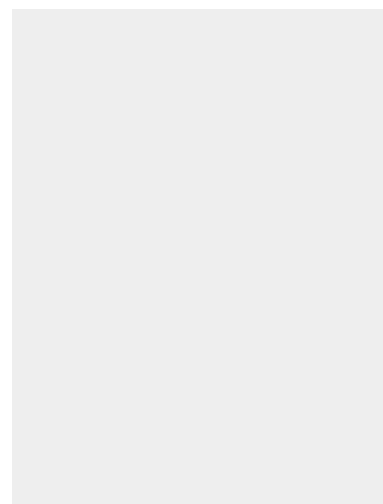

## MR23 Circular connector

160V- 10A

## Technical characteristics

Specifications			
Specifications	DIN EN 60 664 DIN EN 61 984		
Approvals			
Electrical data	Mechanical data		
Number of contacts	9 (8+1)	Housing material	copper alloy, zinc alloy
Rated current	10A	Housing surface	Nickel-plated
mm <sup>2</sup> / AWG	0.03-1.0+0.35-2.5	Contact resistance	≤ 5 mΩ
Rated voltage	160 V	Insulating bodies	PBT
Rated impulse voltage	2.5 kV	Contact material	copper alloy
Pollution degree	3	Contact surface	gold plated
Flammability acc. to UL 94	V0 (UL94)	Mechanical working life	>500
Overvoltage categorie	III	Degree of protection	IP67
		Limiting temperature	-40°C ...+130°C

Forward coding, Crimp terminal  
order crimp contacts separately

Contacts	Cable outlet	Designation	Order No.
9	4.5-8mm	MR23-009-T-D8-SH	181 009 400 2504
	6-10mm	MR23-009-T-D10-SH	181 009 400 2502
	9-14.5mm	MR23-009-T-D14.5-SH	181 009 400 2501

Reverse coding, Crimp terminal  
order crimp contacts separately

Contacts	Cable outlet	Designation	Order No.
9	4.5-8mm	MR23-009R-T-D8-SH	181 009 400 2503
	6-10mm	MR23-009R-T-D10-SH	181 009 400 2505
	9-14.5mm	MR23-009R-T-D14.5-SH	181 009 400 2506

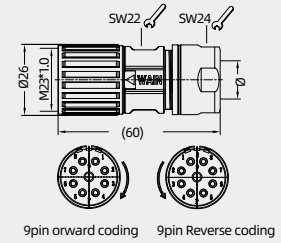

## Crimp contacts

## Crimp contacts 9A

9A



NO.	Wire gauge(mm <sup>2</sup> )	Male	Order No.
①	0.03-0.34	M23-MC9G-0.34	101 031 210 2501
②	0.14-1.0	M23-MC9G-1.0	101 031 210 0801

NO.	Wire gauge(mm <sup>2</sup> )	Female	Order No.
①	0.03-0.34	M23-FC9G-0.34	101 031 220 2501
②	0.14-1.0	M23-FC9G-1.0	101 031 220 0801

NO.	Φa	Φb	Stripping Length
①	1.7	0.9	4mm
②	2.1	1.45	4mm

NO.	Φa	Φb	c	Stripping Length
①	1.7	0.9	14	4mm
②	2.1	1.45	14	4mm

## Crimp contacts 20A

20A



NO.	Wire gauge(mm <sup>2</sup> )	Male	Order No.
①	0.35-2.5	MR23-MC20G-2.5	101 020 210 1001

NO.	Wire gauge(mm <sup>2</sup> )	Female	Order No.
①	0.35-2.5	MR23-FC20G-2.5	101 020 220 1001

## Tools

## Crimping tool



Wire gauge	Designation	Order No.
0.14-4 mm <sup>2</sup>	TL28-2	198 001 001 0039

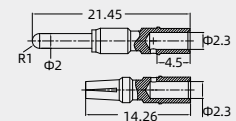

Notes: The tools for crimp terminal may influence the product quality and stability. Please select the tools recognized by our company.



Accessories

Stamped contacts 5A



Contact resistance  $\leq 5m\Omega$

silver plated



gold plated



coil stock



Note: 10kpcs/volume

Tools

Crimping tool



Contact removal tool



Male	Order No.	Female	Order No.
CSSM-0.82P	101 014 110 0750	CSSF-0.82P	101 014 120 0750
CSGM-0.82P	101 014 210 0750	CSGF-0.82P	101 014 220 0750

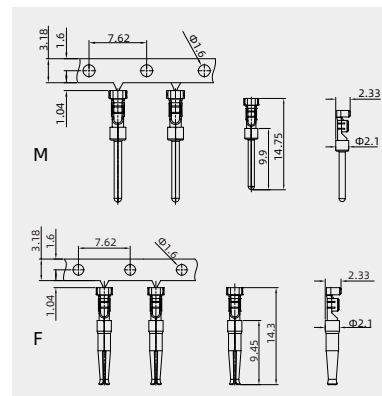

Wire gauge	Designation	Order No.
0.09-0.82mm <sup>2</sup>	TL03	198 001 001 0002
Application	Designation	Order No.
for 5A crimp contact	TL08	198 001 000 0006

Notes: The tools for crimp terminal may influence the product quality and stability. Please select the tools recognized by our company.

## MR23 Circular connector

160V- 10A

## Technical characteristics

Specifications			
Specifications	DIN EN 60 664 DIN EN 61 984		
Approvals			
Electrical data		Mechanical data	
Number of contacts	9	Housing material	copper alloy,zinc alloy
Rated current	10A	Housing surface	Nickel-plated
mm <sup>2</sup> / AWG	0.14-1.0 + 0.35-2.5	Contact resistance	≤ 5 mΩ
Rated voltage	160 V	Insulating bodies	PBT
Rated impulse voltage	2.5 kV	Contact material	copper alloy
Pollution degree	3	Contact surface	gold plated
Flammability acc. to UL 94	V0 (UL94)	Mechanical working life	>500
Overvoltage categorie	III	Degree of protection	IP67
		Limiting temperature	-40°C ...+130°C

Forward coding, Crimp terminal  
order crimp contacts separately

Contacts	Cable outlet	Designation	Order No.
9	4.5-8mm	MR23-009/B-T-D8-SH	181 009 400 2507
	6-10mm	MR23-009/B-T-D10-SH	181 009 400 2508
	9-14.5mm	MR23-009/B-T-D14.5-SH	181 009 400 2509

Reverse coding, Crimp terminal  
order crimp contacts separately

Contacts	Cable outlet	Designation	Order No.
9	4.5-8mm	MR23-009R/B-T-D8-SH	181 009 400 2510
	6-10mm	MR23-009R/B-T-D10-SH	181 009 400 2511
	9-14.5mm	MR23-009R/B-T-D14.5-SH	181 009 400 2512

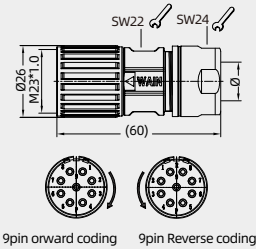

## Crimp contacts

## Crimp contacts 9A

9A



NO.	Wire gauge(mm <sup>2</sup> )	Male	Order No.
①	0.03-0.34	M23-MC9G-0.34	101 031 210 2501
②	0.14-1.0	M23-MC9G-1.0	101 031 210 0801

NO.	Wire gauge(mm <sup>2</sup> )	Female	Order No.
①	0.03-0.34	M23-FC9G-0.34	101 031 220 2501
②	0.14-1.0	M23-FC9G-1.0	101 031 220 0801

NO.	Φa	Φb	Stripping Length
①	1.7	0.9	4mm
②	2.1	1.45	4mm

NO.	Φa	Φb	c	Stripping Length
①	1.7	0.9	14	4mm
②	2.1	1.45	14	4mm

## Tools

## Crimping tool



Wire gauge	Designation	Order No.
0.14-4 mm <sup>2</sup>	TL28-2	198 001 001 0039

Notes: The tools for crimp terminal may influence the product quality and stability. Please select the tools recognized by our company.

Accessories

Stamped contacts

Stamped contacts



coil stock



Note: 10kpcs/volume

NO.	Wire gauge(mm <sup>2</sup> )	Male	Order No.
①	0.08-0.2	M23-MC9G-0.2P	101 031 210 0150
②	0.2-0.52	M23-MC9G-0.52P	101 031 210 0550
③	0.75-1.0	M23-MC9G-1.0P	101 031 210 0850
NO.	Wire gauge(mm <sup>2</sup> )	Female	Order No.
①	0.08-0.2	M23-FC9G-0.2P	101 031 220 0150
②	0.2-0.52	M23-FC9G-0.52P	101 031 220 0550
③	0.75-1.0	M23-FC9G-1.0P	101 031 220 0850

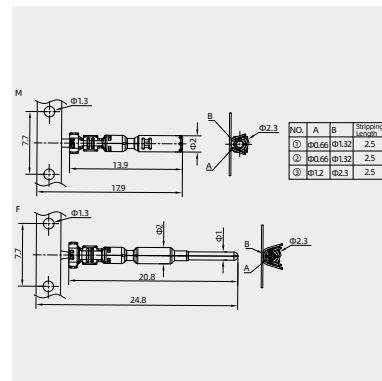

Tools

Terminal stamping machir



Wire gauge	Designation	Order No.
	M23-XC9G-MJ	903 020 000 0548

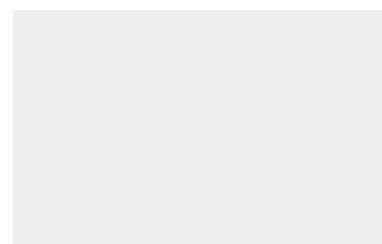

## MR23 Circular connector

160V/125V- 7A

## Technical characteristics

Specifications			
Specifications	DIN EN 60 664		
	DIN EN 61 984		
Approvals			
Electrical data		Mechanical data	
Number of contacts	12	17	Housing material
Rated current	7A	7A	Housing surface
mm <sup>2</sup> / AWG	(0.03-1.0 mm <sup>2</sup> / AWG 32-18)		Contact resistance
Rated voltage	160 V	125 V	Insulating bodies
Rated impulse voltage	2.5 kV	2.0 kV	Contact material
Pollution degree	3	3	Contact surface
Flammability acc. to UL 94	V0 (UL94)	V0 (UL94)	Mechanical working life
Overvoltage categorie	III	III	Degree of protection
			Limiting temperature

Forward coding, Crimp terminal  
order crimp contacts separately

Contacts	Cable outlet	Designation	Order No.
12	4.5-8mm	MR23-012-T-D8-SH	181 012 421 3001
	6-10mm	MR23-012-T-D10-SH	181 012 421 3002
	9-14.5mm	MR23-012-T-D14.5-SH	181 012 421 3003
17	4.5-8mm	MR23-017-T-D8-SH	181 017 400 2001
	6-10mm	MR23-017-T-D10-SH	181 017 400 2002
	9-14.5mm	MR23-017-T-D14.5-SH	181 017 400 2003

Reverse coding, Crimp terminal  
order crimp contacts separately

Contacts	Cable outlet	Designation	Order No.
12	4.5-8mm	MR23-012R-T-D8-SH	181 012 421 3004
	6-10mm	MR23-012R-T-D10-SH	181 012 421 3005
	9-14.5mm	MR23-012R-T-D14.5-SH	181 012 421 3006
17	4.5-8mm	MR23-017R-T-D8-SH	181 017 400 2004
	6-10mm	MR23-017R-T-D10-SH	181 017 400 3005
	9-14.5mm	MR23-017R-T-D14.5-SH	181 017 400 2005

## Crimp contacts

## Crimp contacts 9A

9A



NO.	Wire gauge(mm <sup>2</sup> )	Male	Order No.
①	0.03-0.34	M23-MC9G-0.34	101 031 210 2501
②	0.14-1.0	M23-MC9G-1.0	101 031 210 0801
NO.	Wire gauge(mm <sup>2</sup> )	Female	Order No.
①	0.03-0.34	M23-FC9G-0.34	101 031 220 2501
②	0.14-1.0	M23-FC9G-1.0	101 031 220 0801

## Tools

## Crimping tool



Wire gauge	Designation	Order No.
0.14-4 mm <sup>2</sup>	TL28-2	198 001 001 0039

Notes: The tools for crimp terminal may influence the product quality and stability. Please select the tools recognized by our company.

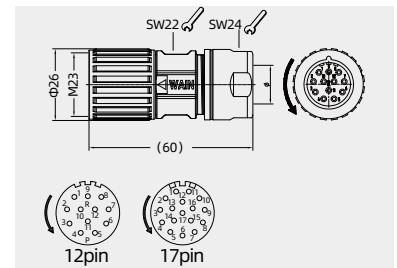
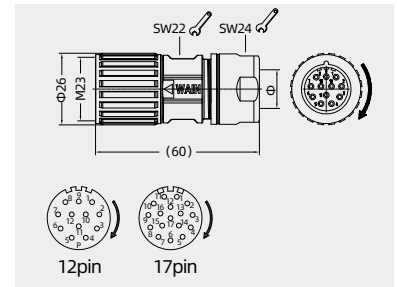
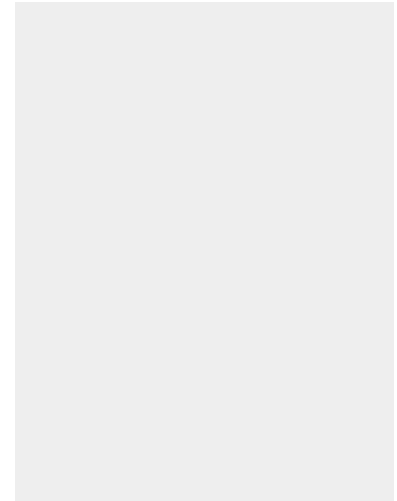

NO.	Φa	Φb	Stripping Length
①	1.7	0.9	4mm
②	2.1	1.45	4mm

NO.	Φa	Φb	c	Stripping Length
①	1.7	0.9	14	4mm
②	2.1	1.45	14	4mm

Accessories

Stamped contacts

Stamped contacts



coil stock



Note: 10kpcs/volume

NO.	Wire gauge(mm <sup>2</sup> )	Male	Order No.
①	0.08-0.2	M23-MC9G-0.2P	101 031 210 0150
②	0.2-0.52	M23-MC9G-0.52P	101 031 210 0550
③	0.75-1.0	M23-MC9G-1.0P	101 031 210 0850
NO.	Wire gauge(mm <sup>2</sup> )	Female	Order No.
①	0.08-0.2	M23-FC9G-0.2P	101 031 220 0150
②	0.2-0.52	M23-FC9G-0.52P	101 031 220 0550
③	0.75-1.0	M23-FC9G-1.0P	101 031 220 0850

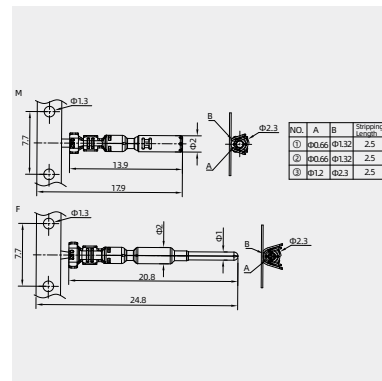

Tools

Terminal stamping machir



Wire gauge	Designation	Order No.
	M23-XC9G-MJ	903 020 000 0548

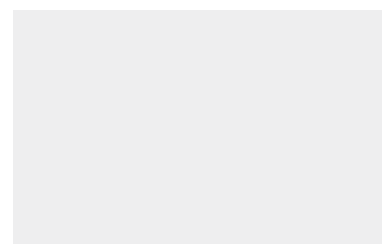

## MR23 Circular connector

63V- 7A

## Technical characteristics

Specifications			
Specifications	DIN EN 60 664 DIN EN 61 984		
Approvals			
Electrical data		Mechanical data	
Number of contacts	19(16+3)	Housing material	copper alloy,zinc alloy
signal:	0.03-1.0 mm <sup>2</sup> / AWG 32-18	Housing surface	Nickel-plated
power:	0.14-1.5 mm <sup>2</sup> / AWG 20-16	Contact resistance	≤ 5 mΩ
Rated current	7A	Insulating bodies	PBT
Rated voltage	63 V	Contact material	copper alloy
Rated impulse voltage	1.5 kV	Contact surface	gold plated
Pollution degree	3	Mechanical working life	>500
Flammability acc. to UL 94	V0 (UL94)	Degree of protection	IP67
Overvoltage categorie	III	Limiting temperature	-40°C ...+130°C

Forward coding, Crimp terminal  
order crimp contacts separately

Contacts	Cable outlet	Designation	Order No.
19	4.5-8mm	MR23-019-T-D8-SH	181 019 400 2001
	6-10mm	MR23-019-T-D10-SH	181 019 400 2002
	9-14.5mm	MR23-019-T-D14.5-SH	181 019 400 2003

Reverse coding, Crimp terminal  
order crimp contacts separately

Contacts	Cable outlet	Designation	Order No.
19	4.5-8mm	MR23-019R-T-D8-SH	181 019 400 2004
	6-10mm	MR23-019R-T-D10-SH	181 019 400 2005
	9-14.5mm	MR23-019R-T-D14.5-SH	181 019 400 2006

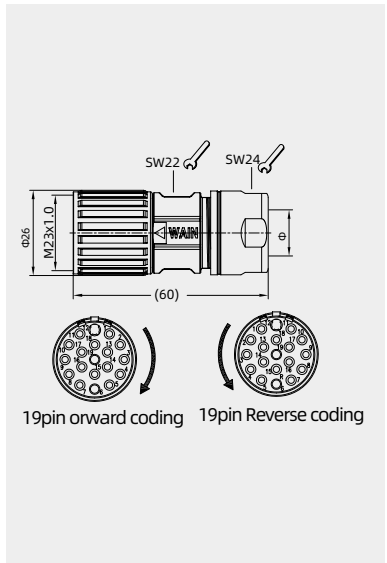
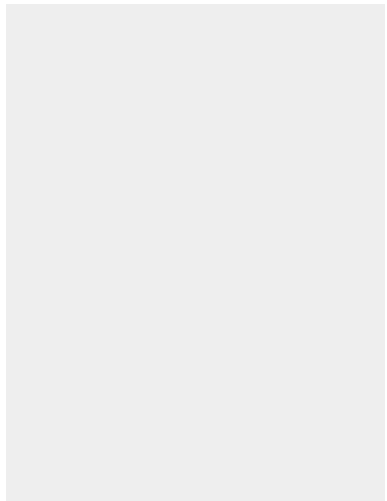

## Crimp contacts

## Crimp contacts 9A/7A

9A(signal)



7A(power)



9A(signal)



7A(power)



NO.	Wire gauge(mm <sup>2</sup> )	Male	Order No.
①	0.03-0.34	M23-MC9G-0.34	101 031 210 2501
②	0.14-1.0	M23-MC9G-1.0	101 031 210 0801
③	0.14-1.4	MR23-MC7G-1.0	101 015 210 0801
④	0.5-1.5	MR23-MC7G-1.5	101 015 210 0901
NO.	Wire gauge(mm <sup>2</sup> )	Female	Order No.
①	0.03-0.34	M23-FC9G-0.34	101 031 220 2501
②	0.14-1.0	M23-FC9G-1.0	101 031 220 0801
③	0.14-1.4	MR23-FC7G-1.0	101 015 220 0801
④	0.5-1.5	MR23-FC7G-1.5	101 015 220 0901

NO.	Φa	Φb	C	Stripping Length
①	1.7	0.9	21	4mm
②	2.1	1.45	21	4mm
③	2.1	1.45	20.65	6mm
④	2.1	1.75	20.65	6mm

NO.	Φa	Φb	C	Stripping Length
①	1.7	0.9	14	4mm
②	2.1	1.45	14	4mm
③	2.1	1.45	13.9	6mm
④	2.1	1.75	13.9	6mm

## Tools

Crimping tool



Wire gauge	Designation	Order No.
0.14-4 mm <sup>2</sup>	TL28-2	198 001 001 0039

Notes: The tools for crimp terminal may influence the product quality and stability. Please select the tools recognized by our company.

Accessories

Stamped contacts

Stamped contacts



coil stock



Note: 10kpcs/volume

NO.	Wire gauge(mm <sup>2</sup> )	Male	Order No.
①	0.08-0.2	M23-MC9G-0.2P	101 031 210 0150
②	0.2-0.52	M23-MC9G-0.52P	101 031 210 0550
③	0.75-1.0	M23-MC9G-1.0P	101 031 210 0850
NO.	Wire gauge(mm <sup>2</sup> )	Female	Order No.
①	0.08-0.2	M23-FC9G-0.2P	101 031 220 0150
②	0.2-0.52	M23-FC9G-0.52P	101 031 220 0550
③	0.75-1.0	M23-FC9G-1.0P	101 031 220 0850

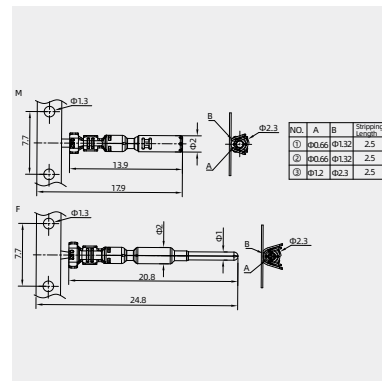

Tools

Terminal stamping machir



Wire gauge	Designation	Order No.
	M23-XC9G-MJ	903 020 000 0548

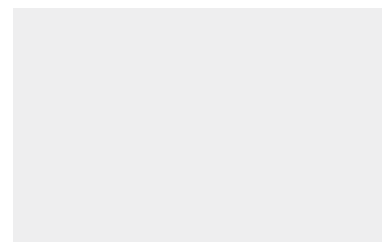

## MR23 Circular connector

300V/160/125 20A/7A



## Technical characteristics

Number of contacts	6/7	12	17
Rated current	20A	7A	7A
mm <sup>2</sup> /AWG	(0.35-2.5mm <sup>2</sup> /AWG22-14)	(0.03-1.0mm <sup>2</sup> /AWG32-18)	(0.03-1.0mm <sup>2</sup> /AWG32-18)
Rated voltage	300V	160V	125V
Rated impulse voltage	2.5KV	2.5KV	2.0KV
Pollution degree	III	III	III
Flammability acc. to UL 94	V0(UL94)	V0(UL94)	V0(UL94)
Overvoltage categorie	III	III	III
Housing material	copper alloy,zinc alloy	copper alloy,zinc alloy	copper alloy,zinc alloy
Housing surface	Nickel-plated	Nickel-plated	Nickel-plated
Contact resistance	≤ 5 mΩ	≤ 5 mΩ	≤ 5 mΩ
Insulating bodies	PBT	PBT	PBT
Contact material	copper alloy	copper alloy	copper alloy
Contact surface	gold plated	gold plated	gold plated
Mechanical working life	> 500	> 500	> 500
Degree of protection	IP67	IP67	IP67
Limiting temperature	-40°C ...+130°C	-40°C ...+130°C	-40°C ...+130°C

Forward coding, Crimp terminal  
order crimp contacts separately

Contacts	Cable outlet	Designation	Order No.
06		MR23-006-SE-D8-SH	181 000 599 2521
		MR23-006-SE-D10-SH	181 000 599 2522
		MR23-006-SE-D14.5-SH	181 000 599 2523
07		MR23-007-SE-D8-SH	181 000 599 2524
		MR23-007-SE-D10-SH	181 000 599 2525
		MR23-007-SE-D14.5-SH	181 000 599 2526
12		MR23-012-SE-D8-SH	181 000 599 1500
		MR23-012-SE-D10-SH	181 000 510 2500
		MR23-012-SE-D14.5-SH	181 000 599 1501
17		MR23-017-SE-D8-SH	181 000 599 2500
		MR23-017-SE-D10-SH	181 000 599 2502
		MR23-017-SE-D14.5-SH	181 000 599 2503

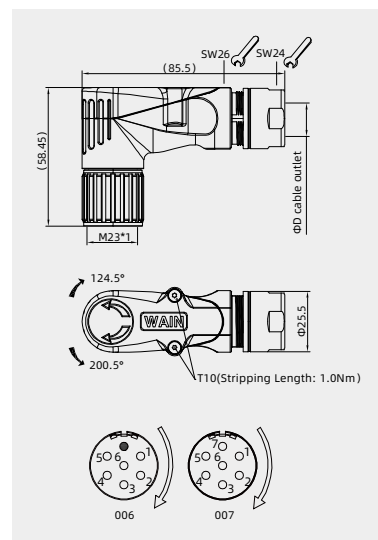

## Crimp contacts

## Crimp contacts 9A

9A



NO.	Wire gauge(mm <sup>2</sup> )	Male	Order No.
①	0.03-0.34	M23-MC9G-0.34	101 031 210 2501
②	0.14-1.0	M23-MC9G-1.0	101 031 210 0801

NO.	Wire gauge(mm <sup>2</sup> )	Female	Order No.
①	0.03-0.34	M23-FC9G-0.34	101 031 220 2501
②	0.14-1.0	M23-FC9G-1.0	101 031 220 0801

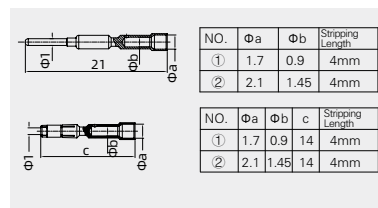

## Crimp contacts 20A

20A



NO.	Wire gauge(mm <sup>2</sup> )	Male	Order No.
①	0.35-2.5	MR23-MC20G-2.5	101 020 210 1001

NO.	Wire gauge(mm <sup>2</sup> )	Female	Order No.
①	0.35-2.5	MR23-FC20G-2.5	101 020 220 1001

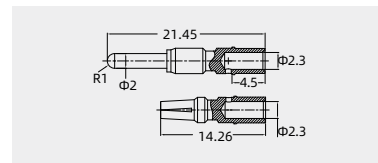

## Tools

## Crimping tool



Wire gauge	Designation	Order No.
0.14-4 mm <sup>2</sup>	TL28-2	198 001 001 0039

Notes: The tools for crimp terminal may influence the product quality and stability. Please select the tools recognized by our company.



Accessories

Stamped contacts

Stamped contacts



coil stock



Note: 10kpcs/volume

NO.	Wire gauge(mm <sup>2</sup> )	Male	Order No.
①	0.08-0.2	M23-MC9G-0.2P	101 031 210 0150
②	0.2-0.52	M23-MC9G-0.52P	101 031 210 0550
③	0.75-1.0	M23-MC9G-1.0P	101 031 210 0850
NO.	Wire gauge(mm <sup>2</sup> )	Female	Order No.
①	0.08-0.2	M23-FC9G-0.2P	101 031 220 0150
②	0.2-0.52	M23-FC9G-0.52P	101 031 220 0550
③	0.75-1.0	M23-FC9G-1.0P	101 031 220 0850

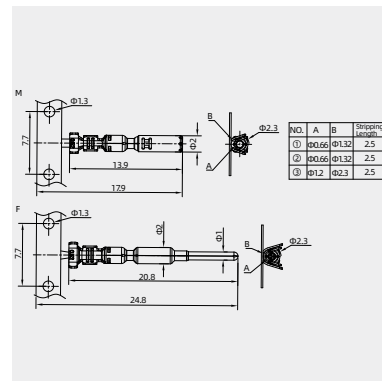

Tools

Terminal stamping machir



Wire gauge	Designation	Order No.
	M23-XC9G-MJ	903 020 000 0548

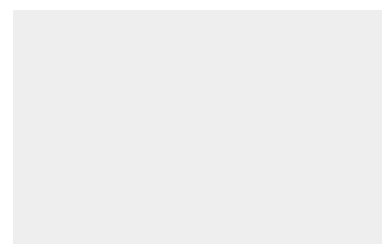

## MR23 Circular connector

300V- 20A



## Technical characteristics

Specifications				
Specifications	DIN EN 60 664			
	DIN EN 61 984			
Approvals				
Electrical data		Mechanical data		
Number of contacts	6	7	Housing material	copper alloy,zinc alloy
Rated current	20A	20A	Housing surface	Nickel-plated
mm <sup>2</sup> / AWG	(0.35-2.5 mm <sup>2</sup> / AWG 22-14)		Contact resistance	≤ 5 mΩ
Rated voltage	300 V	300 V	Insulating bodies	PBT
Rated impulse voltage	2.5 kV	2.5 kV	Contact material	copper alloy
Pollution degree	3	3	Contact surface	gold plated
Flammability acc. to UL 94	V0 (UL94)	V0 (UL94)	Mechanical working life	>500
Overvoltage categorie	III	III	Degree of protection	IP67
			Limiting temperature	-40°C ...+130°C

Reverse coding, Crimp terminal  
order crimp contacts separately

Contacts	Cable outlet	Designation	Order No.
06		MR23-006R-SE-D8-SH	181 000 599 2527
		MR23-006R-SE-D10-SH	181 000 599 2528
		MR23-006R-SE-D14.5-SH	181 000 599 2529
07		MR23-007R-SE-D8-SH	181 000 599 2530
		MR23-007R-SE-D10-SH	181 000 599 2531
		MR23-007R-SE-D14.5-SH	181 000 599 2532
12		MR23-012R-SE-D8-SH	181 000 599 2504
		MR23-012R-SE-D10-SH	181 000 599 0500
		MR23-012R-SE-D14.5-SH	181 000 599 2505
17		MR23-017R-SE-D8-SH	181 000 599 2506
		MR23-017R-SE-D10-SH	181 000 599 2507
		MR23-017R-SE-D14.5-SH	181 000 599 2508

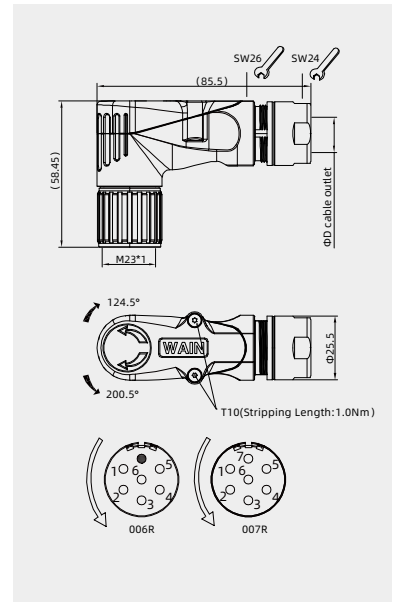
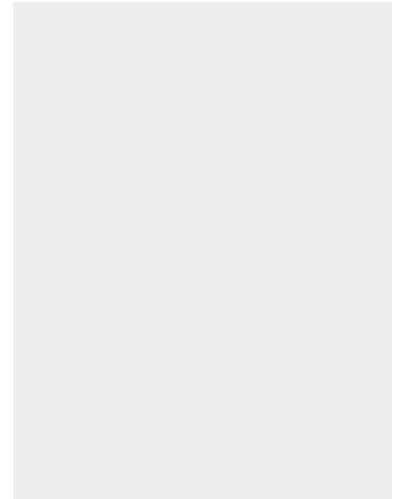

## Crimp contacts

## Crimp contacts 20A

20A



NO.	Wire gauge(mm <sup>2</sup> )	Male	Order No.
①	0.35-2.5	MR23-MC20G-2.5	101 020 210 1001
NO.	Wire gauge(mm <sup>2</sup> )	Female	Order No.
①	0.35-2.5	MR23-FC20G-2.5	101 020 220 1001

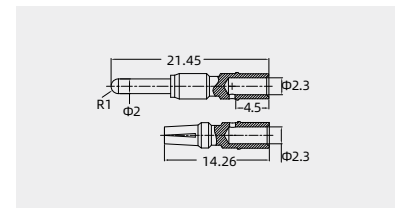

## Tools

## Crimping tool



Wire gauge	Designation	Order No.
0.14-4 mm <sup>2</sup>	TL28-2	198 001 001 0039

Notes: The tools for crimp terminal may influence the product quality and stability. Please select the tools recognized by our company.

## MR23 Circular connector

160V- 10A

## Technical characteristics

Specifications			
Specifications	DIN EN 60 664		
	DIN EN 61 984		
Approvals			
Electrical data		Mechanical data	
Number of contacts	9(8+1)	Housing material	copper alloy,zinc alloy
Signal:	0.14-1.0 mm <sup>2</sup> / AWG 26-18	Housing surface	Nickel-plated
Electricity:	0.35-2.5 mm <sup>2</sup> / AWG 22-14	Insulating bodies	PBT
Rated current(25°C )	10A	Sealing material	FPM
Rated voltage	160 V	Limiting temperature	-40°C ...+130°C
Rated impulse voltage	2.5 kV	Cable diameter	4.5-14.5mm shield
Pollution degree	3	Mechanical working life	>500
		Degree of protection	IP67

Pins must be ordered separately

Forward coding, Crimp terminal  
order crimp contacts separately

Contacts	Cable outlet	Designation	Order No.
9	4.5-8mm	MR23-009-SE-D8-SH	181 009 500 1500
	6-10mm	MR23-009-SE-D10-SH	181 009 500 2500
	9-14.5mm	MR23-009-SE-D14.5-SH	181 009 500 1501

Reverse coding, Crimp terminal  
order crimp contacts separately

Contacts	Cable outlet	Designation	Order No.
9	4.5-8mm	MR23-009R-SE-D8-SH	181 009 500 2504
	6-10mm	MR23-009R-SE-D10-SH	181 009 500 2501
	9-14.5mm	MR23-009R-SE-D14.5-SH	181 009 500 2505

## Crimp contacts

Crimp contacts 9A

9A



NO.	Wire gauge(mm <sup>2</sup> )	Male	Order No.
①	0.03-0.34	M23-MC9G-0.34	101 031 210 2501
②	0.14-1.0	M23-MC9G-1.0	101 031 210 0801

NO.	Wire gauge(mm <sup>2</sup> )	Female	Order No.
①	0.03-0.34	M23-FC9G-0.34	101 031 220 2501
②	0.14-1.0	M23-FC9G-1.0	101 031 220 0801

Crimp contacts 20A

20A



NO.	Wire gauge(mm <sup>2</sup> )	Male	Order No.
①	0.35-2.5	MR23-MC20G-2.5	101 020 210 1001

NO.	Wire gauge(mm <sup>2</sup> )	Female	Order No.
①	0.35-2.5	MR23-FC20G-2.5	101 020 220 1001

Tools

Crimping tool



Wire gauge	Designation	Order No.
0.14-6mm <sup>2</sup>	TL02-2G	198 001 001 0014

Notes: The tools for crimp terminal may influence the product quality and stability. Please select the tools recognized by our company.

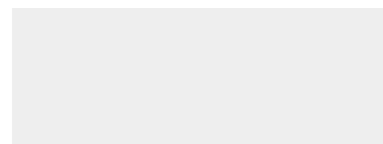
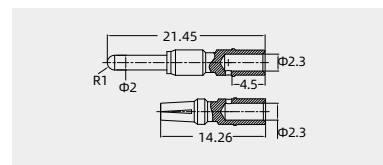
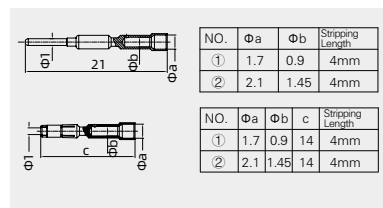
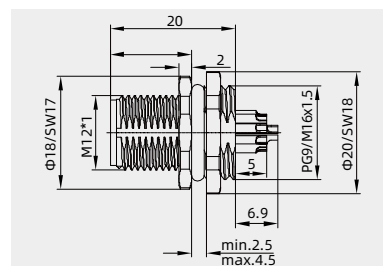
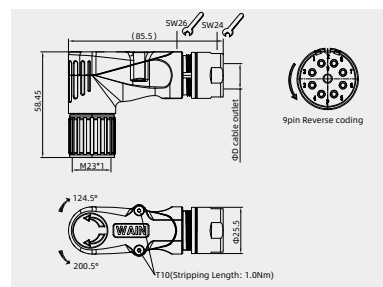
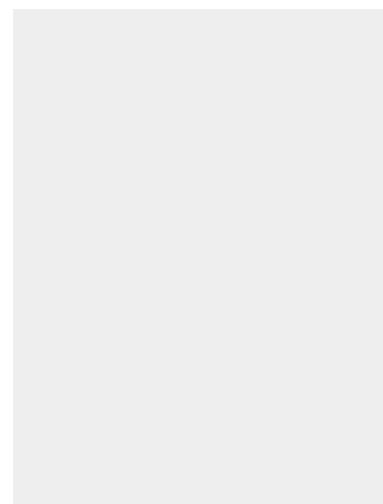

Accessories

Stamped contacts

Stamped contacts



NO.	Wire gauge(mm <sup>2</sup> )	Male	Order No.
①	0.08-0.2	M23-MC9G-0.2P	101 031 210 0150
②	0.2-0.52	M23-MC9G-0.52P	101 031 210 0550
③	0.75-1.0	M23-MC9G-1.0P	101 031 210 0850
NO.	Wire gauge(mm <sup>2</sup> )	Female	Order No.
①	0.08-0.2	M23-FC9G-0.2P	101 031 220 0150
②	0.2-0.52	M23-FC9G-0.52P	101 031 220 0550
③	0.75-1.0	M23-FC9G-1.0P	101 031 220 0850

coil stock



Note: 10kpcs/volume

Tools

Terminal stamping machir



Wire gauge	Designation	Order No.
	M23-XC9G-MJ	903 020 000 0548

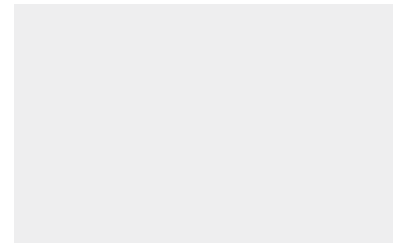
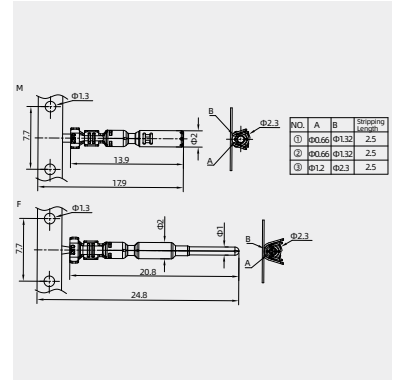

## MR23 Circular connector

63V- 7A

## Technical characteristics

Specifications			
Specifications	DIN EN 60 664 DIN EN 61 984		
Approvals			
Electrical data		Mechanical data	
Number of contacts	19(16+3)	Housing material	copper alloy,zinc alloy
Signal:	0.03-1.0 mm <sup>2</sup> / AWG 32-18	Housing surface	Nickel-plated
Electricity:	0.14-1.5 mm <sup>2</sup> / AWG 20-16	Contact resistance	≤ 5 mΩ
Rated current(25°C )	7A	Insulating bodies	PBT
Rated voltage	63 V	Contact material	copper alloy
Rated impulse voltage	1.5 kV	Contact surface	gold plated
Pollution degree	3	Mechanical working life	>500
Flammability acc. to UL 94	V0 (UL94)	Degree of protection	IP67
Overvoltage categorie	III	Limiting temperature	-40°C ...+130°C



### Forward coding, Crimp terminal order crimp contacts separately



Contacts	Cable outlet	Designation	Order No.
19	4.5-8mm	MR23-019-SE-D8-SH	181 019 500 2500
	6-10mm	MR23-019-SE-D10-SH	181 019 500 2501
	9-14.5mm	MR23-019-SE-D14.5-SH	181 019 500 2502

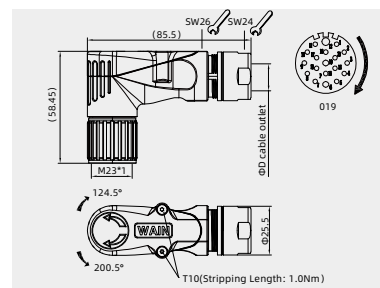

### Reverse coding, Crimp terminal order crimp contacts separately



Contacts	Cable outlet	Designation	Order No.
19	4.5-8mm	MR23-019R-SE-D8-SH	181 019 500 2503
	6-10mm	MR23-019R-SE-D10-SH	181 019 500 2504
	9-14.5mm	MR23-019R-SE-D14.5-SH	181 019 500 2505

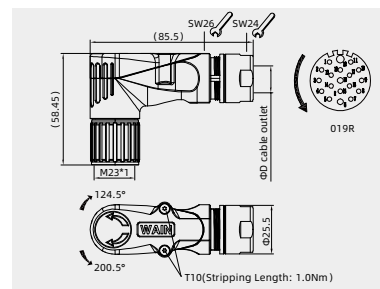

## Crimp contacts

### Crimp contacts 20A

20A



NO.	Wire gauge(mm <sup>2</sup> )	Male	Order No.
①	0.35-2.5	MR23-MC20G-2.5	101 020 210 1001
NO.	Wire gauge(mm <sup>2</sup> )	Female	Order No.
①	0.35-2.5	MR23-FC20G-2.5	101 020 220 1001

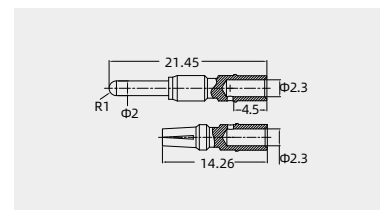

### Tools

#### Crimping tool



Wire gauge	Designation	Order No.
0.14-4 mm <sup>2</sup>	TL28-2	198 001 001 0039

Notes: The tools for crimp terminal may influence the product quality and stability. Please select the tools recognized by our company.

## MR23 Circular connector

300V- 20A



## Technical characteristics

Specifications			
Specifications	DIN EN 60 664		
	DIN EN 61 984		
Approvals			
Electrical data		Mechanical data	
Number of contacts	6	7	Housing material
Rated current	20A	20A	Housing surface
mm <sup>2</sup> / AWG	(0.35-2.5 mm <sup>2</sup> / AWG 22-14)		Contact resistance
Rated voltage	300 V	300 V	Insulating bodies
Rated impulse voltage	2.5 kV	2.5 kV	Contact material
Pollution degree	3	3	Contact surface
Flammability acc. to UL 94	V0 (UL94)	V0 (UL94)	Mechanical working life
Overvoltage categorie	III	III	Degree of protection
			Limiting temperature

Forward coding, Crimp terminal  
order crimp contacts separately

Contacts	Cable outlet	Designation	Order No.
09		MR23-009/B-SE-D8-SH	181 009 500 2509
		MR23-009/B-SE-D10-SH	181 009 500 2510
		MR23-009/B-SE-D14.5-SH	181 009 500 2511

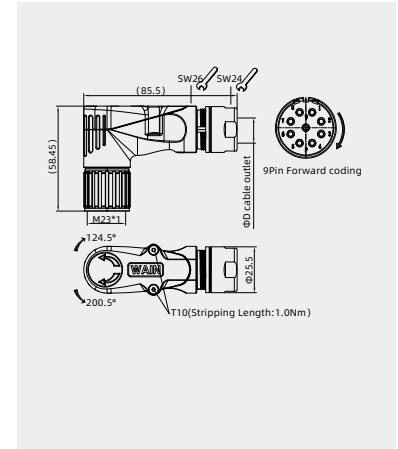

## Crimp contacts

## Crimp contacts 20A

20A



NO.	Wire gauge(mm <sup>2</sup> )	Male	Order No.
①	0.35-2.5	MR23-MC20G-2.5	101 020 210 1001
NO.	Wire gauge(mm <sup>2</sup> )	Female	Order No.
①	0.35-2.5	MR23-FC20G-2.5	101 020 220 1001

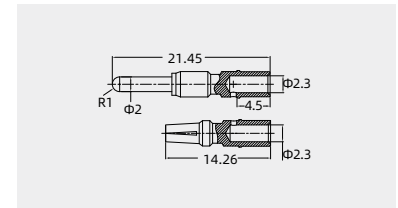

## Tools

## Crimping tool



Wire gauge	Designation	Order No.
0.14-4 mm <sup>2</sup>	TL28-2	198 001 001 0039

Notes: The tools for crimp terminal may influence the product quality and stability. Please select the tools recognized by our company.

## MR23 Circular connector

300V- 20A



## Technical characteristics

Specifications				
Specifications	DIN EN 60 664			
	DIN EN 61 984			
Approvals				
Electrical data		Mechanical data		
Number of contacts	6	7	Housing material	copper alloy,zinc alloy
Rated current	20A	20A	Housing surface	Nickel-plated
mm <sup>2</sup> / AWG	(0.35-2.5 mm <sup>2</sup> / AWG 22-14)		Contact resistance	≤ 5 mΩ
Rated voltage	300 V	300 V	Insulating bodies	PBT
Rated impulse voltage	2.5 kV	2.5 kV	Contact material	copper alloy
Pollution degree	3	3	Contact surface	gold plated
Flammability acc. to UL 94	V0 (UL94)	V0 (UL94)	Mechanical working life	>500
Overvoltage categorie	III	III	Degree of protection	IP67
			Limiting temperature	-40°C ...+130°C

Reverse coding, Crimp terminal  
order crimp contacts separately

Contacts	Cable outlet	Designation	Order No.
09		MR23-009R/B-SE-D8-SH	181 009 500 2515
		MR23-009R/B-SE-D10-SH	181 009 500 2516
		MR23-009R/B-SE-D14.5-SH	181 009 500 2517

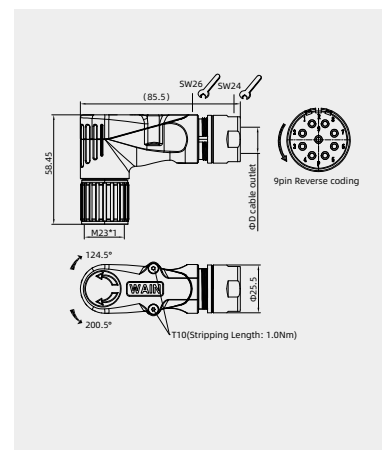

## Crimp contacts

## Crimp contacts 20A

20A



NO.	Wire gauge(mm <sup>2</sup> )	Male	Order No.
①	0.35-2.5	MR23-MC20G-2.5	101 020 210 1001
NO.	Wire gauge(mm <sup>2</sup> )	Female	Order No.
①	0.35-2.5	MR23-FC20G-2.5	101 020 220 1001

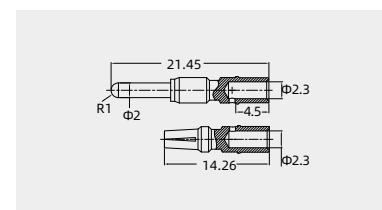

## Tools

## Crimping tool



Wire gauge	Designation	Order No.
0.14-4 mm <sup>2</sup>	TL28-2	198 001 001 0039

Notes: The tools for crimp terminal may influence the product quality and stability. Please select the tools recognized by our company.

## MR23 Circular connector

300V- 20A

## Technical characteristics

Specifications			
Specifications	DIN EN 60 664		
	DIN EN 61 984		
Approvals			
Electrical data		Mechanical data	
Number of contacts	6	7	Housing material
Rated current	20A	20A	Housing surface
mm <sup>2</sup> / AWG	(0.35-2.5 mm <sup>2</sup> / AWG 22-14)		Contact resistance
Rated voltage	300 V	300 V	Insulating bodies
Rated impulse voltage	2.5 kV	2.5 kV	Contact material
Pollution degree	3	3	Contact surface
Flammability acc. to UL 94	V0 (UL94)	V0 (UL94)	Mechanical working life
Overvoltage categorie	III	III	Degree of protection
			Limiting temperature

Forward coding, Crimp terminal  
order crimp contacts separately

Contacts	Designation	Order No.
06	MR23-006-BKP26-SE-OD2.7	181 006 600 3001
07	MR23-007-BKP26-SE-OD2.7	181 007 600 3001
06	MR23-006-BKP26-SE-OD3.2	181 006 600 3002
07	MR23-007-BKP26-SE-OD3.2	181 007 600 3002
06	MR23-006-BKP28.8-SE	181 006 600 3003
07	MR23-007-BKP28.8-SE	181 007 600 3003

Reverse coding, Crimp terminal  
order crimp contacts separately

Contacts	Designation	Order No.
06	MR23-006R-BKP26-SE-OD2.7	181 006 600 3004
07	MR23-007R-BKP26-SE-OD2.7	181 007 600 3004
06	MR23-006R-BKP26-SE-OD3.2	181 006 600 3005
07	MR23-007R-BKP26-SE-OD3.2	181 007 600 3005
06	MR23-006R-BKP28.8-SE	181 006 600 3006
07	MR23-007R-BKP28.8-SE	181 007 600 3006

## Crimp contacts

## Crimp contacts 20A

20A



NO.	Wire gauge(mm <sup>2</sup> )	Male	Order No.
①	0.35-2.5	MR23-MC20G-2.5	101 020 210 1001
NO.	Wire gauge(mm <sup>2</sup> )	Female	Order No.
①	0.35-2.5	MR23-FC20G-2.5	101 020 220 1001

## Tools

## Crimping tool



Wire gauge	Designation	Order No.
0.14-4 mm <sup>2</sup>	TL28-2	198 001 001 0039

Notes: The tools for crimp terminal may influence the product quality and stability. Please select the tools recognized by our company.

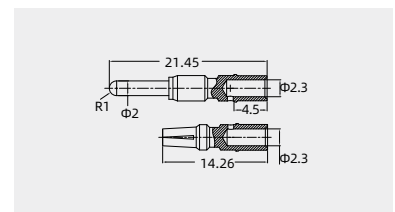
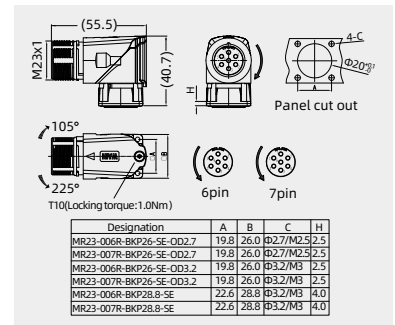
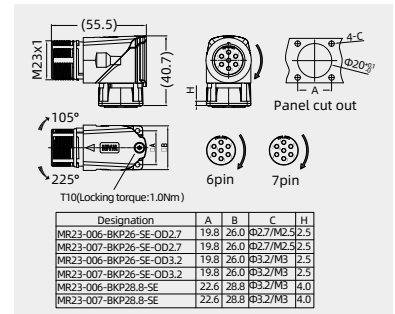
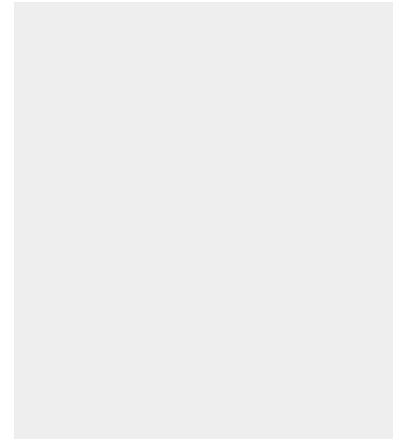



## MR23 Circular connector

160V- 10A

## Technical characteristics

Specifications			
Specifications	DIN EN 60 664		
	DIN EN 61 984		
Approvals			
Electrical data		Mechanical data	
Number of contacts	(8+1)	Housing material	copper alloy,zinc alloy
Rated current	10A	Housing surface	Nickel-plated
mm <sup>2</sup> / AWG	0.03-1.0/0.35-2.5	Contact resistance	≤ 5 mΩ
Rated voltage	160 V	Insulating bodies	PBT
Rated impulse voltage	2.5 kV	Contact material	copper alloy
Pollution degree	3	Contact surface	gold plated
Flammability acc. to UL 94	V0 (UL94)	Mechanical working life	>500
Overvoltage categorie	III	Degree of protection	IP67
		Limiting temperature	-40°C ...+130°C

Forward coding, Crimp terminal  
order crimp contacts separately

Contacts	Cable outlet	Designation	Order No.
9	4.5-8mm	MR23-009-BKP26-SE-OD2.7	181 009 600 2500
	6-10mm	MR23-009-BKP26-SE-OD3.2	181 009 600 2502
	9-14.5mm	MR23-009-BKP28.8-SE	181 009 600 2504

Reverse coding, Crimp terminal  
order crimp contacts separately

Contacts	Cable outlet	Designation	Order No.
9	4.5-8mm	MR23-009R-BKP26-SE-OD2.7	181 009 600 2501
	6-10mm	MR23-009R-BKP26-SE-OD3.2	181 009 600 2503
	9-14.5mm	MR23-009R-BKP28.8-SE	181 009 600 2505

## Crimp contacts

## Crimp contacts 9A

9A



NO.	Wire gauge(mm <sup>2</sup> )	Male	Order No.
①	0.03-0.34	M23-MC9G-0.34	101 031 210 2501
②	0.14-1.0	M23-MC9G-1.0	101 031 210 0801

NO.	Wire gauge(mm <sup>2</sup> )	Female	Order No.
①	0.03-0.34	M23-FC9G-0.34	101 031 220 2501
②	0.14-1.0	M23-FC9G-1.0	101 031 220 0801

## Crimp contacts 20A

20A



NO.	Wire gauge(mm <sup>2</sup> )	Male	Order No.
①	0.35-2.5	MR23-MC20G-2.5	101 020 210 1001

NO.	Wire gauge(mm <sup>2</sup> )	Female	Order No.
①	0.35-2.5	MR23-FC20G-2.5	101 020 220 1001

## Tools

## Crimping tool



Wire gauge	Designation	Order No.
0.14-4 mm <sup>2</sup>	TL28-2	198 001 001 0039

Notes: The tools for crimp terminal may influence the product quality and stability. Please select the tools recognized by our company.

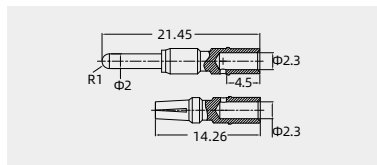
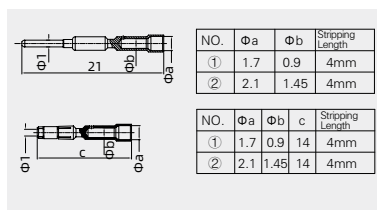
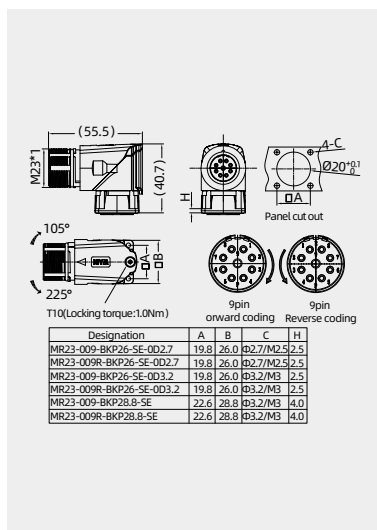
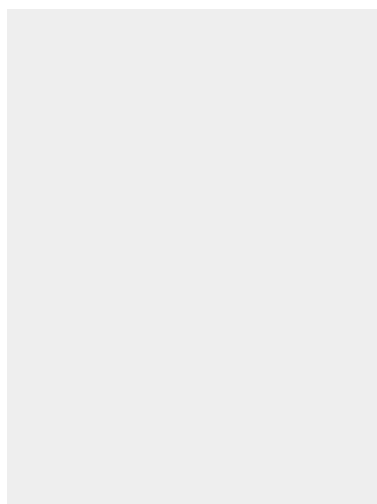

Accessories

Stamped contacts

Stamped contacts



coil stock



Note: 10kpcs/volume

Tools

Terminal stamping machir



NO.	Wire gauge(mm <sup>2</sup> )	Male	Order No.
①	0.08-0.2	M23-MC9G-0.2P	101 031 210 0150
②	0.2-0.52	M23-MC9G-0.52P	101 031 210 0550
③	0.75-1.0	M23-MC9G-1.0P	101 031 210 0850
NO.	Wire gauge(mm <sup>2</sup> )	Female	Order No.
①	0.08-0.2	M23-FC9G-0.2P	101 031 220 0150
②	0.2-0.52	M23-FC9G-0.52P	101 031 220 0550
③	0.75-1.0	M23-FC9G-1.0P	101 031 220 0850

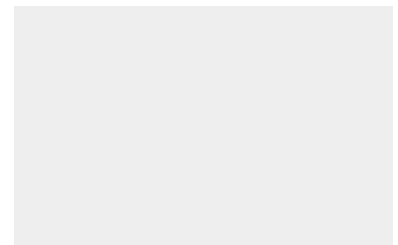
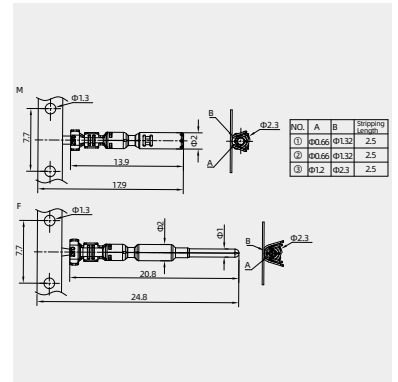

## MR23 Circular connector

160V- 10A

## Technical characteristics

Specifications			
Specifications	DIN EN 60 664		
	DIN EN 61 984		
Approvals			
Electrical data		Mechanical data	
Number of contacts	9	Housing material	copper alloy,zinc alloy
Rated current	10A	Housing surface	Nickel-plated
mm <sup>2</sup> / AWG	0.03-1.0	Contact resistance	≤ 5 mΩ
Rated voltage	160 V	Insulating bodies	PBT
Rated impulse voltage	2.5 kV	Contact material	copper alloy
Pollution degree	3	Contact surface	gold plated
Flammability acc. to UL 94	V0 (UL94)	Mechanical working life	>500
Overvoltage categorie	III	Degree of protection	IP67
		Limiting temperature	-40°C ...+130°C

Forward coding, Crimp terminal  
order crimp contacts separately

Contacts	Cable outlet	Designation	Order No.
9	4.5-8mm	MR23-009/B-BKP26-SE-OD2.7	181 009 600 2506
	6-10mm	MR23-009/B-BKP26-SE-OD3.2	181 009 600 2508
	9-14.5mm	MR23-009/B-BKP28.8-SE	181 009 600 2510

Reverse coding, Crimp terminal  
order crimp contacts separately

Contacts	Cable outlet	Designation	Order No.
9	4.5-8mm	MR23-009R/B-BKP26-SE-OD2.7	181 009 600 2507
	6-10mm	MR23-009R/B-BKP26-SE-OD3.2	181 009 600 2509
	9-14.5mm	MR23-009R/B-BKP28.8-SE	181 009 600 2511

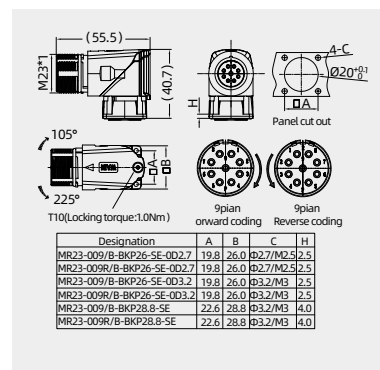
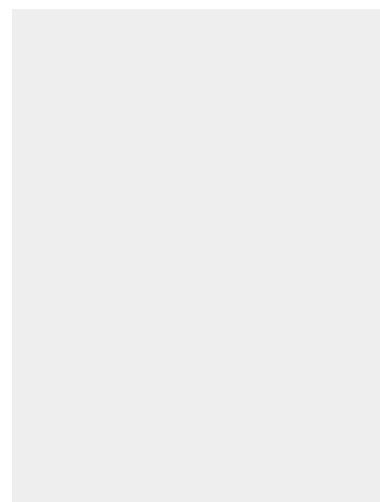

## Crimp contacts

## Crimp contacts 9A

9A



NO.	Wire gauge(mm <sup>2</sup> )	Male	Order No.
①	0.03-0.34	M23-MC9G-0.34	101 031 210 2501
②	0.14-1.0	M23-MC9G-1.0	101 031 210 0801
NO.	Wire gauge(mm <sup>2</sup> )	Female	Order No.
①	0.03-0.34	M23-FC9G-0.34	101 031 220 2501
②	0.14-1.0	M23-FC9G-1.0	101 031 220 0801

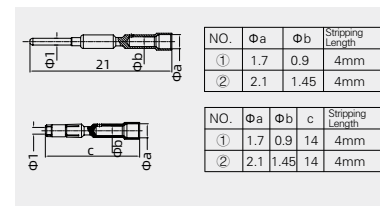

## Tools

## Crimping tool



Wire gauge	Designation	Order No.
0.14-4 mm <sup>2</sup>	TL28-2	198 001 001 0039

Notes: The tools for crimp terminal may influence the product quality and stability. Please select the tools recognized by our company.

Accessories

Stamped contacts

Stamped contacts



NO.	Wire gauge(mm <sup>2</sup> )	Male	Order No.
①	0.08-0.2	M23-MC9G-0.2P	101 031 210 0150
②	0.2-0.52	M23-MC9G-0.52P	101 031 210 0550
③	0.75-1.0	M23-MC9G-1.0P	101 031 210 0850
NO.	Wire gauge(mm <sup>2</sup> )	Female	Order No.
①	0.08-0.2	M23-FC9G-0.2P	101 031 220 0150
②	0.2-0.52	M23-FC9G-0.52P	101 031 220 0550
③	0.75-1.0	M23-FC9G-1.0P	101 031 220 0850

coil stock



Note: 10kpcs/volume

Tools

Terminal stamping machir



Wire gauge	Designation	Order No.
	M23-XC9G-MJ	903 020 000 0548

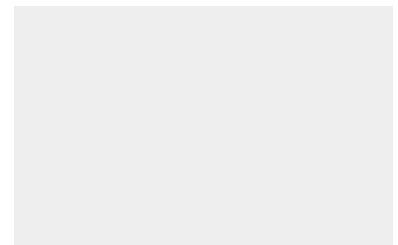
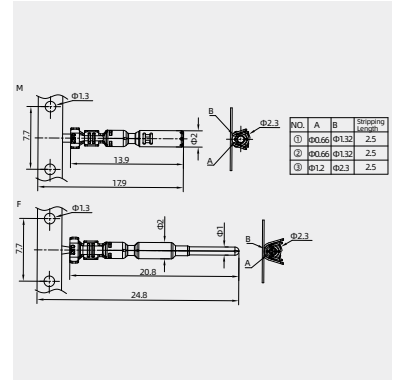

## MR23 Circular connector

160V/125V- 7A

## Technical characteristics

Specifications			
Specifications	DIN EN 60 664		
	DIN EN 61 984		
Approvals			
Electrical data		Mechanical data	
Number of contacts	12	17	Housing material
Rated current	7A	7A	Housing surface
mm <sup>2</sup> / AWG	(0.03-1.0 mm <sup>2</sup> / AWG 32-18)		Contact resistance
Rated voltage	160 V	125 V	Insulating bodies
Rated impulse voltage	2.5 kV	2.0 kV	Contact material
Pollution degree	3	3	Contact surface
Flammability acc. to UL 94	V0 (UL94)	V0 (UL94)	Mechanical working life
Overvoltage categorie	III	III	Degree of protection
			Limiting temperature

Forward coding, Crimp terminal  
order crimp contacts separately

Contacts	Designation	Order No.
12	MR23-012-BKP26-SE	181 012 600 3001
17	MR23-017-BKP26-SE	181 017 600 2003
12	MR23-012-BKP26-SE-OD3.2	181 000 099 2501
17	MR23-017-BKP26-SE-OD3.2	181 017 600 3004
12	MR23-012-BKP28.8-SE	181 012 600 2001
17	MR23-017-BKP28.8-SE	181 017 600 2001

Reverse coding, Crimp terminal  
order crimp contacts separately

Contacts	Designation	Order No.
12	MR23-012R-BKP26-SE	181 012 600 3002
17	MR23-017R-BKP26-SE	181 017 600 2004
12	MR23-012R-BKP26-SE-OD3.2	181 012 600 3004
17	MR23-017R-BKP26-SE-OD3.2	181 000 099 2500
12	MR23-012R-BKP28.8-SE	181 012 600 2002
17	MR23-017R-BKP28.8-SE	181 017 600 2002

## Crimp contacts

## Crimp contacts 9A

9A



NO.	Wire gauge(mm <sup>2</sup> )	Male	Order No.
①	0.03-0.34	M23-MC9G-0.34	101 031 210 2501
②	0.14-1.0	M23-MC9G-1.0	101 031 210 0801
NO.	Wire gauge(mm <sup>2</sup> )	Female	Order No.
①	0.03-0.34	M23-FC9G-0.34	101 031 220 2501
②	0.14-1.0	M23-FC9G-1.0	101 031 220 0801

## Tools

## Crimping tool



Wire gauge	Designation	Order No.
0.14-4 mm <sup>2</sup>	TL28-2	198 001 001 0039

Notes: The tools for crimp terminal may influence the product quality and stability. Please select the tools recognized by our company.

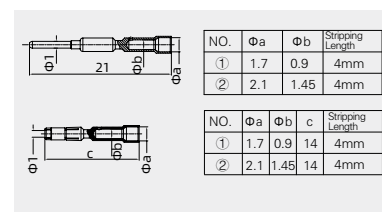
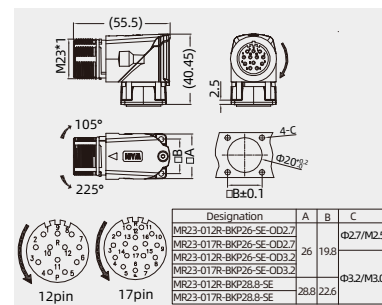
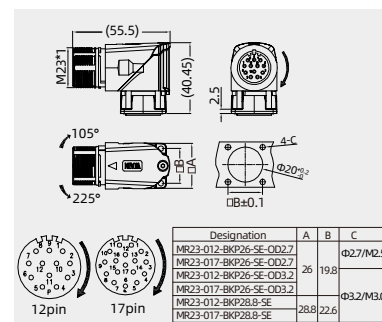
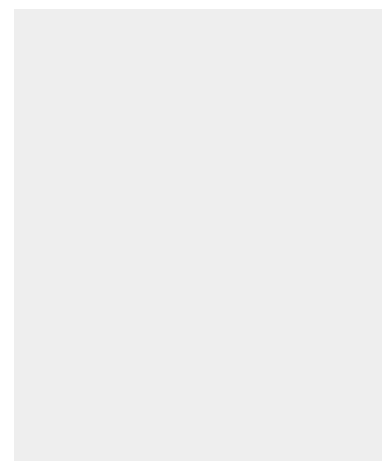

Accessories

Stamped contacts

Stamped contacts



coil stock



Note: 10kpcs/volume

Tools

Terminal stamping machir



NO.	Wire gauge(mm <sup>2</sup> )	Male	Order No.
①	0.08-0.2	M23-MC9G-0.2P	101 031 210 0150
②	0.2-0.52	M23-MC9G-0.52P	101 031 210 0550
③	0.75-1.0	M23-MC9G-1.0P	101 031 210 0850
NO.	Wire gauge(mm <sup>2</sup> )	Female	Order No.
①	0.08-0.2	M23-FC9G-0.2P	101 031 220 0150
②	0.2-0.52	M23-FC9G-0.52P	101 031 220 0550
③	0.75-1.0	M23-FC9G-1.0P	101 031 220 0850

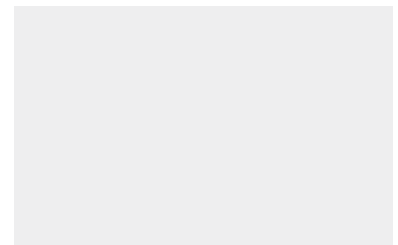
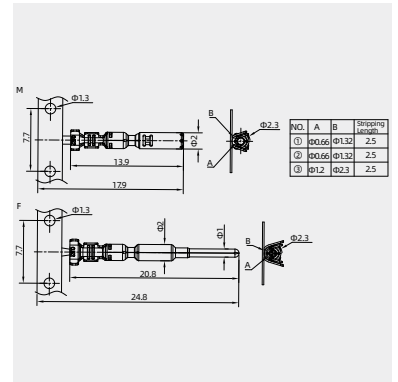

## MR23 Circular connector

63V- 7A

## Technical characteristics

Specifications			
Specifications	DIN EN 60 664		
	DIN EN 61 984		
Approvals			
Electrical data		Mechanical data	
Number of contacts	19(16+3)	Housing material	copper alloy,zinc alloy
signal:	0.03-1.0 mm <sup>2</sup> / AWG 32-18	Housing surface	Nickel-plated
power:	0.14-1.5 mm <sup>2</sup> / AWG 20-16	Contact resistance	≤ 5 mΩ
Rated current	7A	Insulating bodies	PBT
Rated voltage	63 V	Contact material	copper alloy
Rated impulse voltage	1.5 kV	Contact surface	gold plated
Pollution degree	3	Mechanical working life	>500
Flammability acc. to UL 94	V0 (UL94)	Degree of protection	IP67
Overvoltage categorie	III	Limiting temperature	-40°C ...+130°C

Forward coding, Crimp terminal  
order crimp contacts separately

Contacts	Designation	Order No.
19	MR23-019-BKP26-SE-OD2.7	181 019 300 1001
	MR23-019-BKP26-SE-OD3.2	181 019 300 1002
	MR23-019-BKP28.8-SE	181 019 300 1003

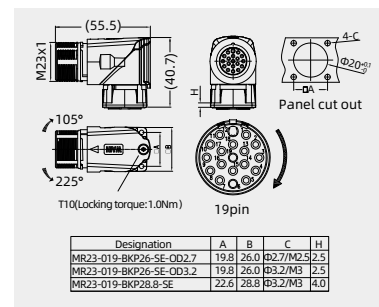
Reverse coding, Crimp terminal  
order crimp contacts separately

Contacts	Designation	Order No.
19	MR23-019R-BKP26-SE-OD2.7	181 019 300 1004
	MR23-019R-BKP26-SE-OD3.2	181 019 300 1005
	MR23-019R-BKP28.8-SE	181 019 300 1006

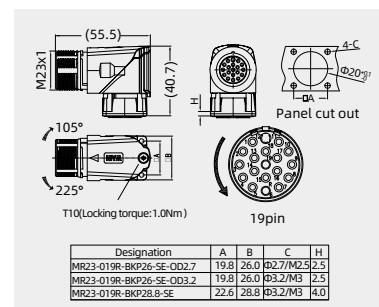

## Crimp contacts

## Crimp contacts 9A/7A

9A(signal)



7A(power)



9A(signal)



7A(power)



NO.	Wire gauge(mm <sup>2</sup> )	Male	Order No.
①	0.03-0.34	M23-MC9G-0.34	101 031 210 2501
②	0.14-1.0	M23-MC9G-1.0	101 031 210 0801
③	0.14-1.4	MR23-MC7G-1.0	101 015 210 0801
④	0.5-1.5	MR23-MC7G-1.5	101 015 210 0901
NO.	Wire gauge(mm <sup>2</sup> )	Female	Order No.
①	0.03-0.34	M23-FC9G-0.34	101 031 220 2501
②	0.14-1.0	M23-FC9G-1.0	101 031 220 0801
③	0.14-1.4	MR23-FC7G-1.0	101 015 220 0801
④	0.5-1.5	MR23-FC7G-1.5	101 015 220 0901

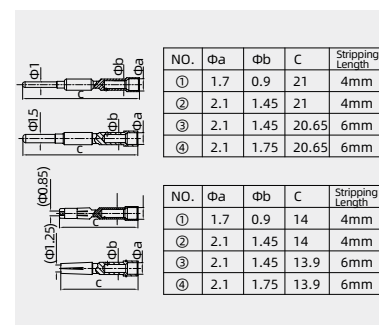

## Tools

Crimping tool



Wire gauge	Designation	Order No.
0.14-4 mm <sup>2</sup>	TL28-2	198 001 001 0039

Notes: The tools for crimp terminal may influence the product quality and stability. Please select the tools recognized by our company.

Accessories

Stamped contacts

Stamped contacts



NO.	Wire gauge(mm <sup>2</sup> )	Male	Order No.
①	0.08-0.2	M23-MC9G-0.2P	101 031 210 0150
②	0.2-0.52	M23-MC9G-0.52P	101 031 210 0550
③	0.75-1.0	M23-MC9G-1.0P	101 031 210 0850
NO.	Wire gauge(mm <sup>2</sup> )	Female	Order No.
①	0.08-0.2	M23-FC9G-0.2P	101 031 220 0150
②	0.2-0.52	M23-FC9G-0.52P	101 031 220 0550
③	0.75-1.0	M23-FC9G-1.0P	101 031 220 0850

coil stock



Note: 10kpcs/volume

Tools

Terminal stamping machir



Wire gauge	Designation	Order No.
	M23-XC9G-MJ	903 020 000 0548

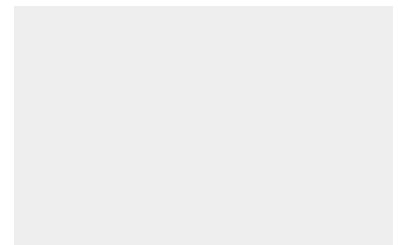
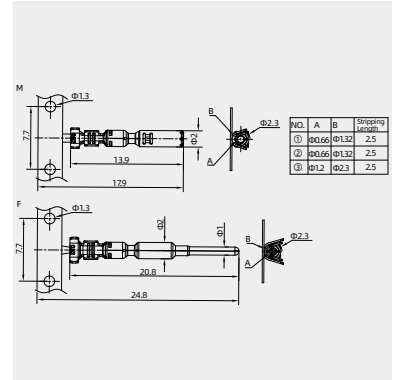



## MR23 Circular connector

300V- 20A

## Technical characteristics

Specifications				
Specifications	DIN EN 60 664 DIN EN 61 984			
Approvals				
Electrical data		Mechanical data		
Number of contacts	6	7	Housing material	copper alloy,zinc alloy
Rated current	20A	20A	Housing surface	Nickel-plated
mm <sup>2</sup> / AWG	(0.35-2.5 mm <sup>2</sup> / AWG 22-14)		Contact resistance	≤ 5 mΩ
Rated voltage	300 V	300 V	Insulating bodies	PBT
Rated impulse voltage	2.5 kV	2.5 kV	Contact material	copper alloy
Pollution degree	3	3	Contact surface	gold plated
Flammability acc. to UL 94	V0 (UL94)	V0 (UL94)	Mechanical working life	>500
Overvoltage categorie	III	III	Degree of protection	IP67
			Limiting temperature	-40°C ...+130°C

Forward coding, Crimp terminal  
order crimp contacts separately

Contacts	Designation	Order No.
6	MR23-006-BK26-OD2.7	181 006 300 3001
7	MR23-007-BK26-OD2.7	181 007 300 3001
6	MR23-006-BK26-OD3.2	181 006 300 3002
7	MR23-007-BK26-OD3.2	181 007 300 3002
6	MR23-006-BK28-OD3.2	166 000 399 2500
7	MR23-007-BK28-OD3.2	166 000 399 2501

Reverse coding, Crimp terminal  
order crimp contacts separately

Contacts	Designation	Order No.
6	MR23-006R-BK26-OD2.7	181 006 300 3003
7	MR23-007R-BK26-OD2.7	181 007 300 3003
6	MR23-006R-BK26-OD3.2	181 006 300 3004
7	MR23-007R-BK26-OD3.2	181 007 300 3004
6	MR23-006R-BK28-OD3.2	166 000 399 2502
7	MR23-007R-BK28-OD3.2	166 000 399 2503

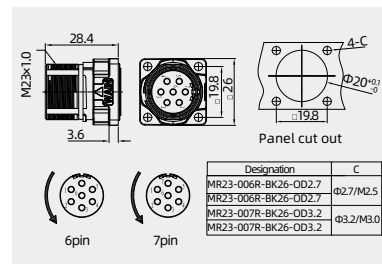
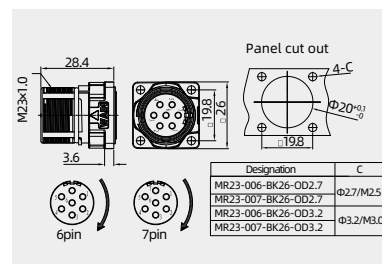
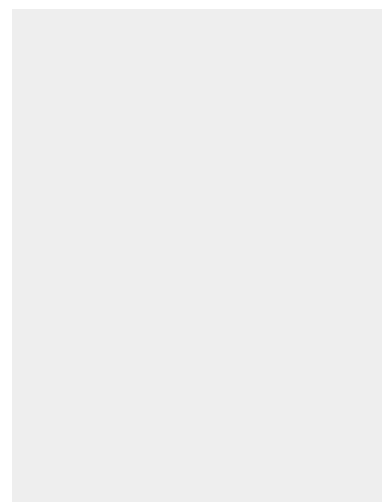

## Crimp contacts

## Crimp contacts 20A

20A



NO.	Wire gauge(mm <sup>2</sup> )	Male	Order No.
①	0.35-2.5	MR23-MC20G-2.5	101 020 210 1001
NO.	Wire gauge(mm <sup>2</sup> )	Female	Order No.
①	0.35-2.5	MR23-FC20G-2.5	101 020 220 1001

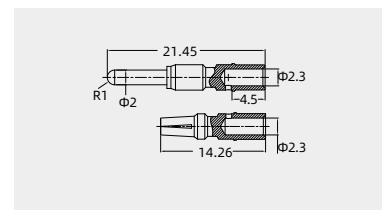

## Tools

## Crimping tool



Wire gauge	Designation	Order No.
0.14-4 mm <sup>2</sup>	TL28-2	198 001 001 0039

Notes: The tools for crimp terminal may influence the product quality and stability. Please select the tools recognized by our company.

## MR23 Circular connector

160V- 10A

## Technical characteristics

Specifications			
Specifications	DIN EN 60 664		
	DIN EN 61 984		
Approvals			
Electrical data		Mechanical data	
Number of contacts	9 (8+1)	Housing material	copper alloy,zinc alloy
Rated current	10A	Housing surface	Nickel-plated
mm <sup>2</sup> / AWG	0.03-1.0+0.35-2.5	Contact resistance	≤ 5 mΩ
Rated voltage	160 V	Insulating bodies	PBT
Rated impulse voltage	2.5 kV	Contact material	copper alloy
Pollution degree	3	Contact surface	gold plated
Flammability acc. to UL 94	V0 (UL94)	Mechanical working life	>500
Overvoltage categorie	III	Degree of protection	IP67
		Limiting temperature	-40°C ...+130°C

Forward coding, Crimp terminal  
order crimp contacts separately

Contacts	Designation	Order No.
9	MR23-009-BK26-OD2.7	181 009 300 1500
	MR23-009-BK26-OD3.2	181 009 300 1501
	MR23-009-BK28-OD3.2	181 009 300 1508

Reverse coding, Crimp terminal  
order crimp contacts separately

Contacts	Designation	Order No.
9	MR23-009R-BK26-OD2.7	181 009 300 1504
	MR23-009R-BK26-OD3.2	181 009 300 1505
	MR23-009R-BK28-OD3.2	181 009 300 1510

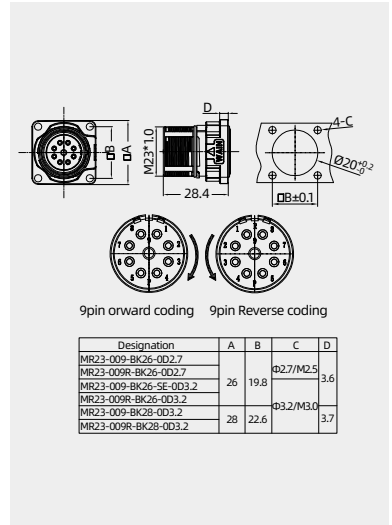
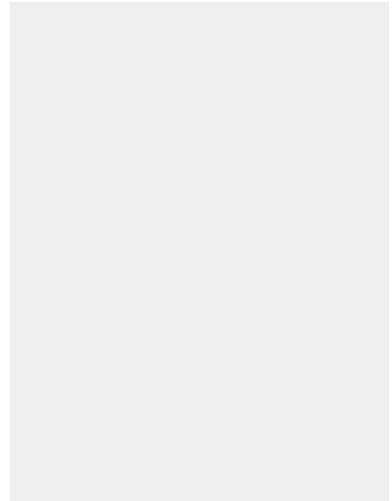

## Crimp contacts

## Crimp contacts 9A

9A



NO.	Wire gauge(mm <sup>2</sup> )	Male	Order No.
①	0.03-0.34	M23-MC9G-0.34	101 031 210 2501
②	0.14-1.0	M23-MC9G-1.0	101 031 210 0801

NO.	Wire gauge(mm <sup>2</sup> )	Female	Order No.
①	0.03-0.34	M23-FC9G-0.34	101 031 220 2501
②	0.14-1.0	M23-FC9G-1.0	101 031 220 0801

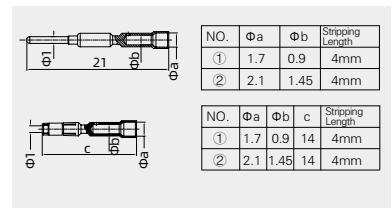

## Crimp contacts 20A

20A



NO.	Wire gauge(mm <sup>2</sup> )	Male	Order No.
①	0.35-2.5	MR23-MC20G-2.5	101 020 210 1001

NO.	Wire gauge(mm <sup>2</sup> )	Female	Order No.
①	0.35-2.5	MR23-FC20G-2.5	101 020 220 1001

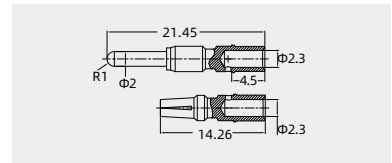

## Tools

## Crimping tool



Wire gauge	Designation	Order No.
0.14-4 mm <sup>2</sup>	TL28-2	198 001 001 0039

Notes: The tools for crimp terminal may influence the product quality and stability. Please select the tools recognized by our company.

Accessories

Stamped contacts

Stamped contacts



coil stock



Note: 10kpcs/volume

NO.	Wire gauge(mm <sup>2</sup> )	Male	Order No.
①	0.08-0.2	M23-MC9G-0.2P	101 031 210 0150
②	0.2-0.52	M23-MC9G-0.52P	101 031 210 0550
③	0.75-1.0	M23-MC9G-1.0P	101 031 210 0850
NO.	Wire gauge(mm <sup>2</sup> )	Female	Order No.
①	0.08-0.2	M23-FC9G-0.2P	101 031 220 0150
②	0.2-0.52	M23-FC9G-0.52P	101 031 220 0550
③	0.75-1.0	M23-FC9G-1.0P	101 031 220 0850

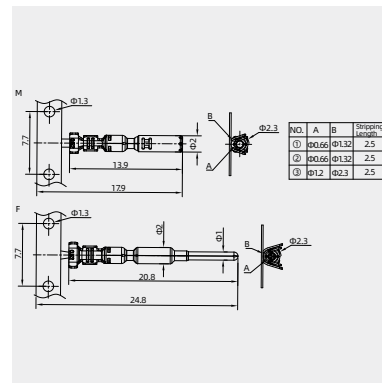

Tools

Terminal stamping machir



Wire gauge	Designation	Order No.
	M23-XC9G-MJ	903 020 000 0548

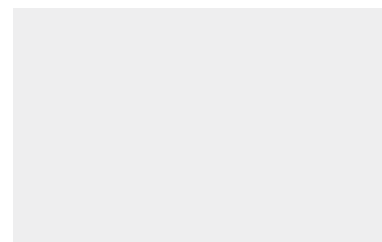

## MR23 Circular connector

160V- 10A

## Technical characteristics

Specifications			
Specifications	DIN EN 60 664		
	DIN EN 61 984		
Approvals			
Electrical data		Mechanical data	
Number of contacts	9	Housing material	copper alloy,zinc alloy
Rated current	10A	Housing surface	Nickel-plated
mm <sup>2</sup> / AWG	0.03-1.0	Contact resistance	≤ 5 mΩ
Rated voltage	160 V	Insulating bodies	PBT
Rated impulse voltage	2.5 kV	Contact material	copper alloy
Pollution degree	3	Contact surface	gold plated
Flammability acc. to UL 94	V0 (UL94)	Mechanical working life	>500
Overvoltage categorie	III	Degree of protection	IP67
		Limiting temperature	-40°C ...+130°C

Forward coding, Crimp terminal  
order crimp contacts separately

Contacts	Designation	Order No.
9	MR23-009/B-BK26-OD2.7	181 009 300 1502
	MR23-009/B-BK26-OD3.2	181 009 300 1503
	MR23-009/B-BK28-OD3.2	181 009 300 1509

Reverse coding, Crimp terminal  
order crimp contacts separately

Contacts	Designation	Order No.
9	MR23-009R/B-BK26-OD2.7	181 009 300 1506
	MR23-009R/B-BK26-OD3.2	181 009 300 1507
	MR23-009R/B-BK28-OD3.2	181 009 300 1511

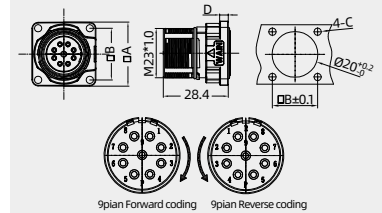

Designation	A	B	C	D
MR23-009/B-BK26-OD2.7				
MR23-009R/B-BK26-OD2.7	26	19.8	∅2.7/M2.5	3.6
MR23-009/B-BK26-SE-OD3.2				
MR23-009R/B-BK26-OD3.2			∅3.2/M3.0	
MR23-009/B-BK28-OD3.2	28	22.6		3.7

## Crimp contacts

## Crimp contacts 9A

9A



NO.	Wire gauge(mm <sup>2</sup> )	Male	Order No.
①	0.03-0.34	M23-MC9G-0.34	101 031 210 2501
②	0.14-1.0	M23-MC9G-1.0	101 031 210 0801

NO.	Wire gauge(mm <sup>2</sup> )	Female	Order No.
①	0.03-0.34	M23-FC9G-0.34	101 031 220 2501
②	0.14-1.0	M23-FC9G-1.0	101 031 220 0801

NO.	Φa	Φb	Stripping Length
①	1.7	0.9	4mm
②	2.1	1.45	4mm

NO.	Φa	Φb	c	Stripping Length
①	1.7	0.9	14	4mm
②	2.1	1.45	14	4mm

## Tools

## Crimping tool



Wire gauge	Designation	Order No.
0.14-4 mm <sup>2</sup>	TL28-2	198 001 001 0039

Notes: The tools for crimp terminal may influence the product quality and stability. Please select the tools recognized by our company.

Accessories

Stamped contacts

Stamped contacts



coil stock



Note: 10kpcs/volume

NO.	Wire gauge(mm <sup>2</sup> )	Male	Order No.
①	0.08-0.2	M23-MC9G-0.2P	101 031 210 0150
②	0.2-0.52	M23-MC9G-0.52P	101 031 210 0550
③	0.75-1.0	M23-MC9G-1.0P	101 031 210 0850
NO.	Wire gauge(mm <sup>2</sup> )	Female	Order No.
①	0.08-0.2	M23-FC9G-0.2P	101 031 220 0150
②	0.2-0.52	M23-FC9G-0.52P	101 031 220 0550
③	0.75-1.0	M23-FC9G-1.0P	101 031 220 0850

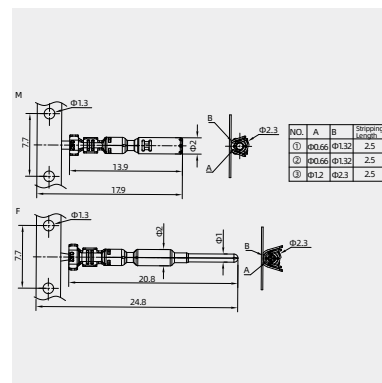

Tools

Terminal stamping machir



Wire gauge	Designation	Order No.
	M23-XC9G-MJ	903 020 000 0548

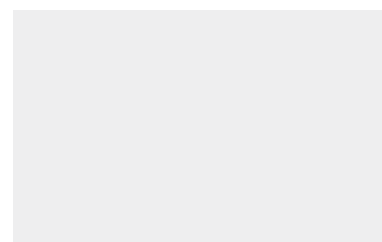

## MR23 Circular connector

160V/125V- 7A

## Technical characteristics

Specifications			
Specifications	DIN EN 60 664		
	DIN EN 61 984		
Approvals			
Electrical data		Mechanical data	
Number of contacts	12	17	Housing material
Rated current	7A	7A	Housing surface
mm <sup>2</sup> / AWG	(0.03-1.0 mm <sup>2</sup> / AWG 32-18)		Contact resistance
Rated voltage	160 V	125 V	Insulating bodies
Rated impulse voltage	2.5 kV	2.0 kV	Contact material
Pollution degree	3	3	Contact surface
Flammability acc. to UL 94	V0 (UL94)	V0 (UL94)	Mechanical working life
Overvoltage categorie	III	III	Degree of protection
			Limiting temperature

Forward coding, Crimp terminal  
order crimp contacts separately

Contacts	Designation	Order No.
12	MR23-012-BK26-OD2.7	181 012 300 2001
17	MR23-017-BK26-OD2.7	181 017 300 2001
12	MR23-012-BK26-OD3.2	181 012 300 3001
17	MR23-017-BK26-OD3.2	181 017 300 3001
12	MR23-012-BK28-OD3.2	181 012 300 2003
17	MR23-017-BK28-OD3.2	181 017 300 2004

Reverse coding, Crimp terminal  
order crimp contacts separately

Contacts	Designation	Order No.
12	MR23-012R-BK26-OD2.7	181 012 300 2002
17	MR23-017R-BK26-OD2.7	181 017 300 2002
12	MR23-012R-BK26-OD3.2	181 012 300 3002
17	MR23-017R-BK26-OD3.2	181 017 300 2003
12	MR23-012R-BK28-OD3.2	181 012 300 2004
17	MR23-017R-BK28-OD3.2	181 017 300 2005

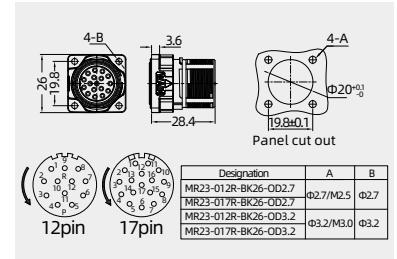
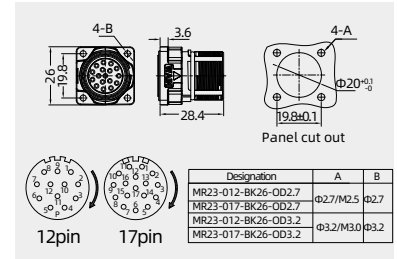
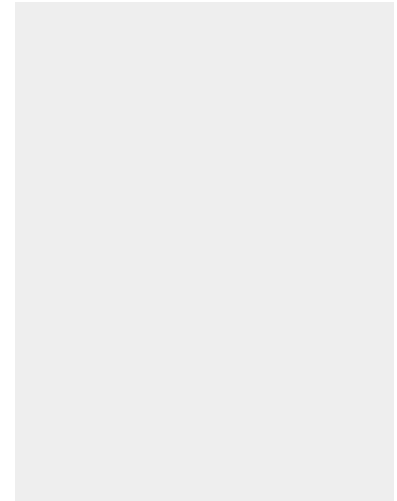

## Crimp contacts

## Crimp contacts 9A

9A



NO.	Wire gauge(mm <sup>2</sup> )	Male	Order No.
①	0.03-0.34	M23-MC9G-0.34	101 031 210 2501
②	0.14-1.0	M23-MC9G-1.0	101 031 210 0801

NO.	Wire gauge(mm <sup>2</sup> )	Female	Order No.
①	0.03-0.34	M23-FC9G-0.34	101 031 220 2501
②	0.14-1.0	M23-FC9G-1.0	101 031 220 0801

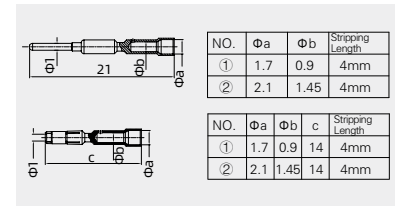

## Tools

## Crimping tool



Wire gauge	Designation	Order No.
0.14-4 mm <sup>2</sup>	TL28-2	198 001 001 0039

Notes: The tools for crimp terminal may influence the product quality and stability. Please select the tools recognized by our company.

Accessories

Stamped contacts

Stamped contacts



coil stock



Note: 10kpcs/volume

NO.	Wire gauge(mm <sup>2</sup> )	Male	Order No.
①	0.08-0.2	M23-MC9G-0.2P	101 031 210 0150
②	0.2-0.52	M23-MC9G-0.52P	101 031 210 0550
③	0.75-1.0	M23-MC9G-1.0P	101 031 210 0850
NO.	Wire gauge(mm <sup>2</sup> )	Female	Order No.
①	0.08-0.2	M23-FC9G-0.2P	101 031 220 0150
②	0.2-0.52	M23-FC9G-0.52P	101 031 220 0550
③	0.75-1.0	M23-FC9G-1.0P	101 031 220 0850

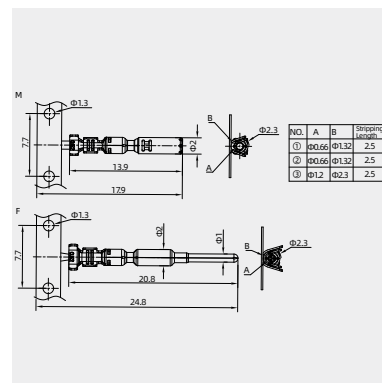

Tools

Terminal stamping machir



Wire gauge	Designation	Order No.
	M23-XC9G-MJ	903 020 000 0548

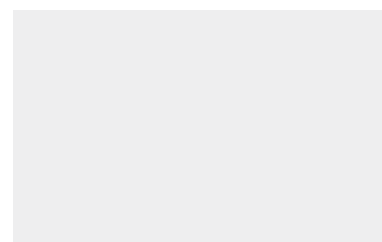

## MR23 Circular connector

63V- 7A

## Technical characteristics

Specifications			
Specifications	DIN EN 60 664		
	DIN EN 61 984		
Approvals			
Electrical data		Mechanical data	
Number of contacts	19(16+3)	Housing material	copper alloy,zinc alloy
signal:	0.03-1.0 mm <sup>2</sup> / AWG 32-18	Housing surface	Nickel-plated
power:	0.14-1.5 mm <sup>2</sup> / AWG 20-16	Contact resistance	≤ 5 mΩ
Rated current	7A	Insulating bodies	PBT
Rated voltage	63 V	Contact material	copper alloy
Rated impulse voltage	1.5 kV	Contact surface	gold plated
Pollution degree	3	Mechanical working life	>500
Flammability acc. to UL 94	V0 (UL94)	Degree of protection	IP67
Overvoltage categorie	III	Limiting temperature	-40°C ...+130°C

Forward coding, Crimp terminal  
order crimp contacts separately

Contacts	Designation	Order No.
19	MR23-019-BK26-OD2.7	181 019 300 1007
	MR23-019-BK26-OD3.2	181 019 300 1008
	MR23-019-BK28-OD3.2	166 000 399 2504

Reverse coding, Crimp terminal  
order crimp contacts separately

Contacts	Designation	Order No.
19	MR23-019R-BK26-OD2.7	181 019 300 1009
	MR23-019R-BK26-OD3.2	181 019 300 1010
	MR23-019R-BK28-OD3.2	166 000 399 2505

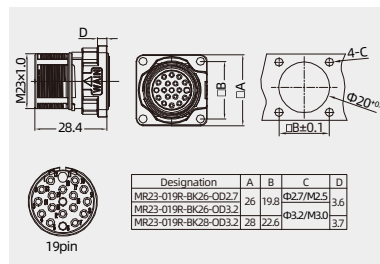
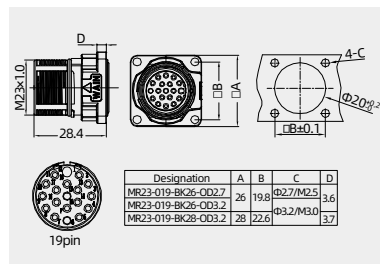
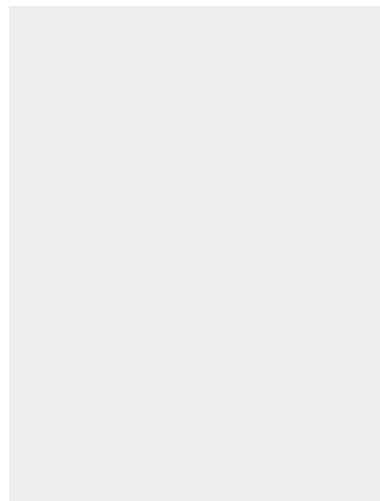

## Crimp contacts

## Crimp contacts 9A/7A

9A(signal)



7A(power)



9A(signal)



7A(power)



NO.	Wire gauge(mm <sup>2</sup> )	Male	Order No.
①	0.03-0.34	M23-MC9G-0.34	101 031 210 2501
②	0.14-1.0	M23-MC9G-1.0	101 031 210 0801
③	0.14-1.4	MR23-MC7G-1.0	101 015 210 0801
④	0.5-1.5	MR23-MC7G-1.5	101 015 210 0901
NO.	Wire gauge(mm <sup>2</sup> )	Female	Order No.
①	0.03-0.34	M23-FC9G-0.34	101 031 220 2501
②	0.14-1.0	M23-FC9G-1.0	101 031 220 0801
③	0.14-1.4	MR23-FC7G-1.0	101 015 220 0801
④	0.5-1.5	MR23-FC7G-1.5	101 015 220 0901

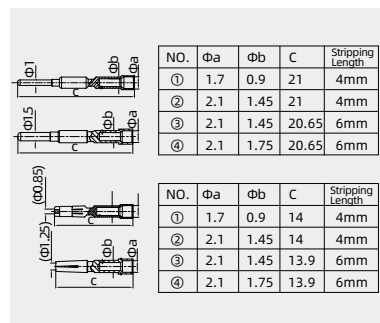

## Tools

Crimping tool



Wire gauge	Designation	Order No.
0.14-4 mm <sup>2</sup>	TL28-2	198 001 001 0039

Notes: The tools for crimp terminal may influence the product quality and stability. Please select the tools recognized by our company.



Accessories

Stamped contacts

Stamped contacts



coil stock



Note: 10kpcs/volume

NO.	Wire gauge(mm <sup>2</sup> )	Male	Order No.
①	0.08-0.2	M23-MC9G-0.2P	101 031 210 0150
②	0.2-0.52	M23-MC9G-0.52P	101 031 210 0550
③	0.75-1.0	M23-MC9G-1.0P	101 031 210 0850
NO.	Wire gauge(mm <sup>2</sup> )	Female	Order No.
①	0.08-0.2	M23-FC9G-0.2P	101 031 220 0150
②	0.2-0.52	M23-FC9G-0.52P	101 031 220 0550
③	0.75-1.0	M23-FC9G-1.0P	101 031 220 0850

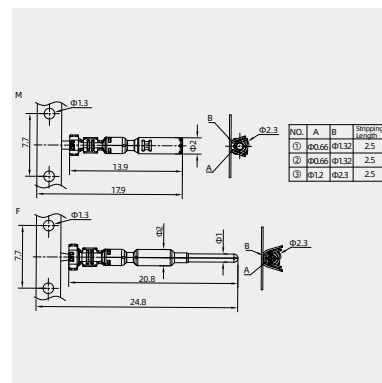

Tools

Terminal stamping machir



Wire gauge	Designation	Order No.
	M23-XC9G-MJ	903 020 000 0548

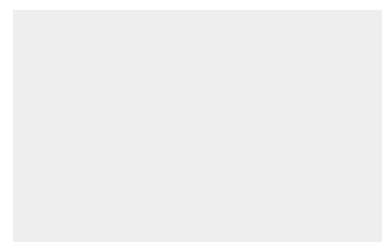

## MR23 Circular connector

300V- 20A

## Technical characteristics

Specifications				
Specifications	DIN EN 60 664			
	DIN EN 61 984			
Approvals				
Electrical data		Mechanical data		
Number of contacts	6	7	Housing material	copper alloy,zinc alloy
Rated current	20A	20A	Housing surface	Nickel-plated
mm <sup>2</sup> / AWG	(0.35-2.5 mm <sup>2</sup> / AWG 22-14)		Contact resistance	≤ 5 mΩ
Rated voltage	300 V	300 V	Insulating bodies	PBT
Rated impulse voltage	2.5 kV	2.5 kV	Contact material	copper alloy
Pollution degree	3	3	Contact surface	gold plated
Flammability acc. to UL 94	V0 (UL94)	V0 (UL94)	Mechanical working life	>500
Overvoltage categorie	III	III	Degree of protection	IP67
			Limiting temperature	-40°C ...+130°C

Forward coding, Crimp terminal  
order crimp contacts separately

Contacts	Designation	Order No.
6	MR23-006-BK-M20	181 006 300 3005
7	MR23-007-BK-M20	181 007 300 3005

Reverse coding, Crimp terminal  
order crimp contacts separately

Contacts	Designation	Order No.
6	MR23-006R-BK-M20	181 006 300 3006
7	MR23-007R-BK-M20	181 007 300 3006

## Crimp contacts

## Crimp contacts 20A

20A



NO.	Wire gauge(mm <sup>2</sup> )	Male	Order No.
①	0.35-2.5	MR23-MC20G-2.5	101 020 210 1001

NO.	Wire gauge(mm <sup>2</sup> )	Female	Order No.
①	0.35-2.5	MR23-FC20G-2.5	101 020 220 1001

## Tools

## Crimping tool



Wire gauge	Designation	Order No.
0.14-4 mm <sup>2</sup>	TL28-2	198 001 001 0039

Notes: The tools for crimp terminal may influence the product quality and stability. Please select the tools recognized by our company.

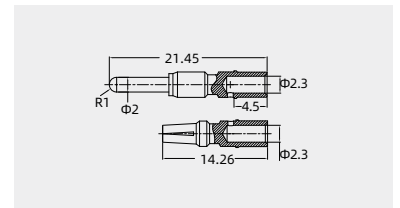
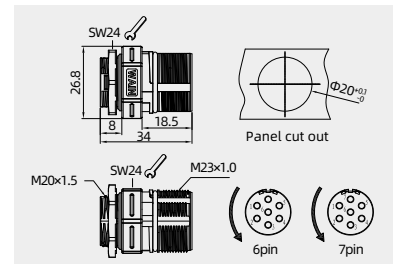
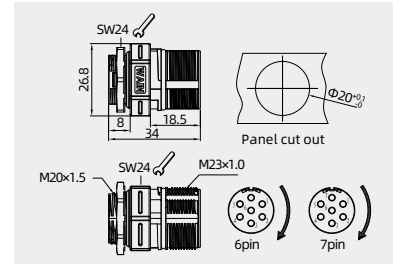
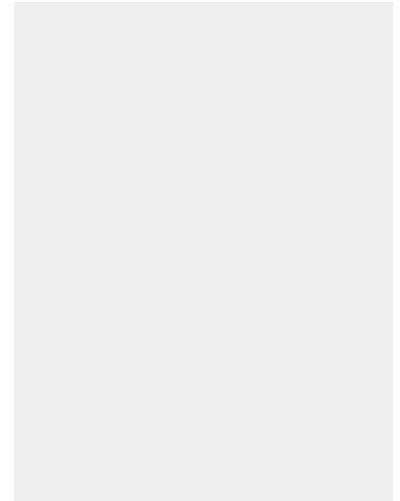

## MR23 Circular connector

160V- 10A

## Technical characteristics

Specifications			
Specifications	DIN EN 60 664		
	DIN EN 61 984		
Approvals			
Electrical data		Mechanical data	
Number of contacts	9 (8+1)	Housing material	copper alloy,zinc alloy
Rated current	10A	Housing surface	Nickel-plated
mm <sup>2</sup> / AWG	0.03-1.0+0.35-2.5	Contact resistance	≤ 5 mΩ
Rated voltage	160 V	Insulating bodies	PBT
Rated impulse voltage	2.5 kV	Contact material	copper alloy
Pollution degree	3	Contact surface	gold plated
Flammability acc. to UL 94	V0 (UL94)	Mechanical working life	>500
Overvoltage categorie	III	Degree of protection	IP67
		Limiting temperature	-40°C ...+130°C

Forward coding, Crimp terminal  
order crimp contacts separately

Contacts	Designation	Order No.
9	MR23-009-BK-M20	181 009 300 1512

Reverse coding, Crimp terminal  
order crimp contacts separately

Contacts	Designation	Order No.
9	MR23-009R-BK-M20	181 009 300 1514

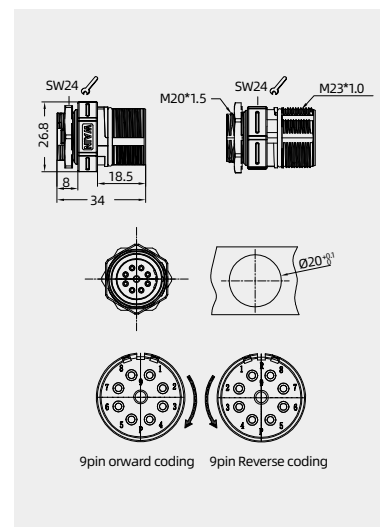
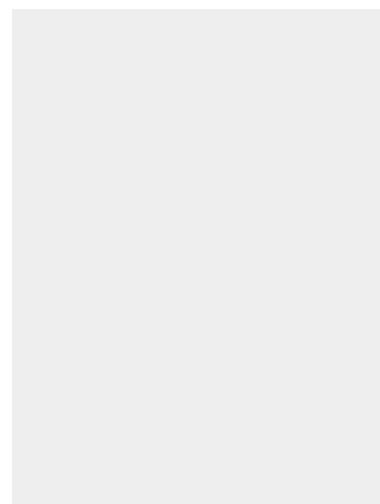

## Crimp contacts

## Crimp contacts 9A

9A



NO.	Wire gauge(mm <sup>2</sup> )	Male	Order No.
①	0.03-0.34	M23-MC9G-0.34	101 031 210 2501
②	0.14-1.0	M23-MC9G-1.0	101 031 210 0801

NO.	Wire gauge(mm <sup>2</sup> )	Female	Order No.
①	0.03-0.34	M23-FC9G-0.34	101 031 220 2501
②	0.14-1.0	M23-FC9G-1.0	101 031 220 0801

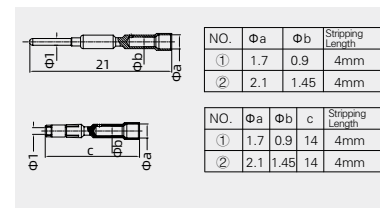

## Crimp contacts 20A

20A



NO.	Wire gauge(mm <sup>2</sup> )	Male	Order No.
①	0.35-2.5	MR23-MC20G-2.5	101 020 210 1001

NO.	Wire gauge(mm <sup>2</sup> )	Female	Order No.
①	0.35-2.5	MR23-FC20G-2.5	101 020 220 1001

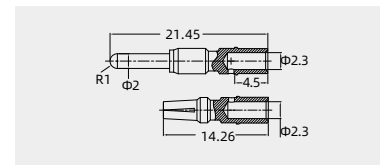

## Tools

Crimping tool



Wire gauge	Designation	Order No.
0.14-4 mm <sup>2</sup>	TL28-2	198 001 001 0039

Notes: The tools for crimp terminal may influence the product quality and stability. Please select the tools recognized by our company.

Accessories

Stamped contacts

Stamped contacts



coil stock



Note: 10kpcs/volume

Tools

Terminal stamping machir



NO.	Wire gauge(mm <sup>2</sup> )	Male	Order No.
①	0.08-0.2	M23-MC9G-0.2P	101 031 210 0150
②	0.2-0.52	M23-MC9G-0.52P	101 031 210 0550
③	0.75-1.0	M23-MC9G-1.0P	101 031 210 0850
NO.	Wire gauge(mm <sup>2</sup> )	Female	Order No.
①	0.08-0.2	M23-FC9G-0.2P	101 031 220 0150
②	0.2-0.52	M23-FC9G-0.52P	101 031 220 0550
③	0.75-1.0	M23-FC9G-1.0P	101 031 220 0850

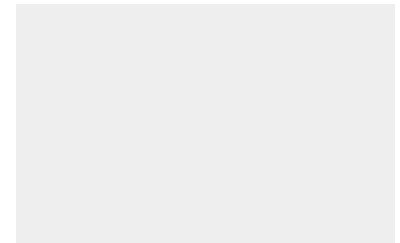
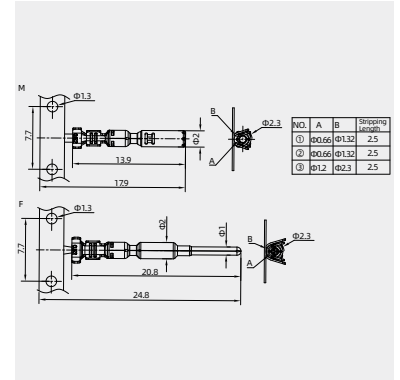

## MR23 Circular connector

160V- 10A

## Technical characteristics

Specifications			
Specifications	DIN EN 60 664		
	DIN EN 61 984		
Approvals			
Electrical data		Mechanical data	
Number of contacts	9	Housing material	copper alloy,zinc alloy
Rated current	10A	Housing surface	Nickel-plated
mm <sup>2</sup> / AWG	0.03-1.0	Contact resistance	≤ 5 mΩ
Rated voltage	160 V	Insulating bodies	PBT
Rated impulse voltage	2.5 kV	Contact material	copper alloy
Pollution degree	3	Contact surface	gold plated
Flammability acc. to UL 94	V0 (UL94)	Mechanical working life	>500
Overvoltage categorie	III	Degree of protection	IP67
		Limiting temperature	-40°C ...+130°C

Forward coding, Crimp terminal  
order crimp contacts separately

Contacts	Designation	Order No.
9	MR23-009/B-BK-M20	181 009 300 1513

Reverse coding, Crimp terminal  
order crimp contacts separately

Contacts	Designation	Order No.
9	MR23-009R/B-BK-M20	181 009 300 1515

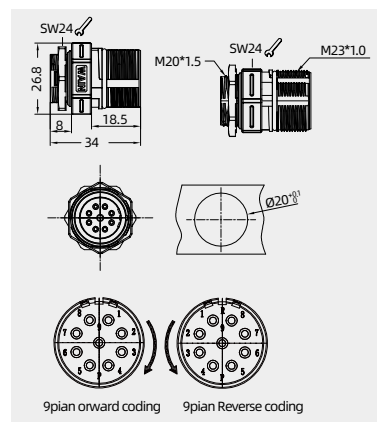

## Crimp contacts

## Crimp contacts 9A

9A



NO.	Wire gauge(mm <sup>2</sup> )	Male	Order No.
①	0.03-0.34	M23-MC9G-0.34	101 031 210 2501
②	0.14-1.0	M23-MC9G-1.0	101 031 210 0801
NO.	Wire gauge(mm <sup>2</sup> )	Female	Order No.
①	0.03-0.34	M23-FC9G-0.34	101 031 220 2501
②	0.14-1.0	M23-FC9G-1.0	101 031 220 0801

NO.	Φa	Φb	Stripping Length
①	1.7	0.9	4mm
②	2.1	1.45	4mm

NO.	Φa	Φb	c	Stripping Length
①	1.7	0.9	14	4mm
②	2.1	1.45	14	4mm

## Tools

## Crimping tool



Wire gauge	Designation	Order No.
0.14-4 mm <sup>2</sup>	TL28-2	198 001 001 0039

Notes: The tools for crimp terminal may influence the product quality and stability. Please select the tools recognized by our company.

Accessories

Stamped contacts

Stamped contacts



NO.	Wire gauge(mm <sup>2</sup> )	Male	Order No.
①	0.08-0.2	M23-MC9G-0.2P	101 031 210 0150
②	0.2-0.52	M23-MC9G-0.52P	101 031 210 0550
③	0.75-1.0	M23-MC9G-1.0P	101 031 210 0850
NO.	Wire gauge(mm <sup>2</sup> )	Female	Order No.
①	0.08-0.2	M23-FC9G-0.2P	101 031 220 0150
②	0.2-0.52	M23-FC9G-0.52P	101 031 220 0550
③	0.75-1.0	M23-FC9G-1.0P	101 031 220 0850

coil stock



Note: 10kpcs/volume

Tools

Terminal stamping machir



Wire gauge	Designation	Order No.
	M23-XC9G-MJ	903 020 000 0548

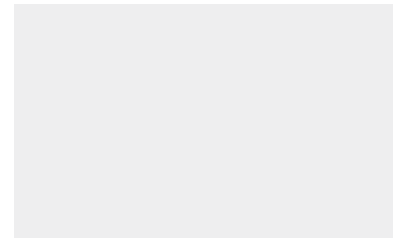
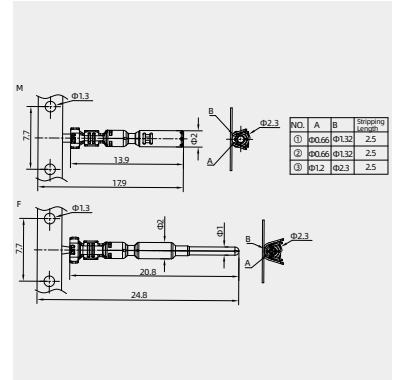

## MR23 Circular connector

160V/125V- 7A

## Technical characteristics

Specifications			
Specifications	DIN EN 60 664		
	DIN EN 61 984		
Approvals			
Electrical data		Mechanical data	
Number of contacts	12	17	Housing material
Rated current	7A	7A	Housing surface
mm <sup>2</sup> / AWG	(0.03-1.0 mm <sup>2</sup> / AWG 32-18)		Contact resistance
Rated voltage	160 V	125 V	Insulating bodies
Rated impulse voltage	2.5 kV	2.0 kV	Contact material
Pollution degree	3	3	Contact surface
Flammability acc. to UL 94	V0 (UL94)	V0 (UL94)	Mechanical working life
Overvoltage categorie	III	III	Degree of protection
			Limiting temperature

Forward coding, Crimp terminal  
order crimp contacts separately

Contacts	Designation	Order No.
12	MR23-012-BK-M20	181 012 300 3003
17	MR23-017-BK-M20	181 017 300 3002

Reverse coding, Crimp terminal  
order crimp contacts separately

Contacts	Designation	Order No.
12	MR23-012R-BK-M20	181 012 300 3004
17	MR23-017R-BK-M20	181 017 300 3003

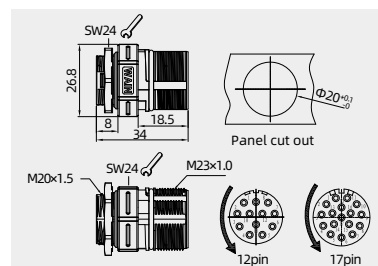
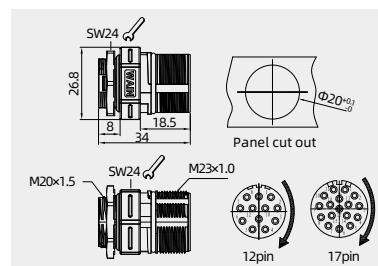
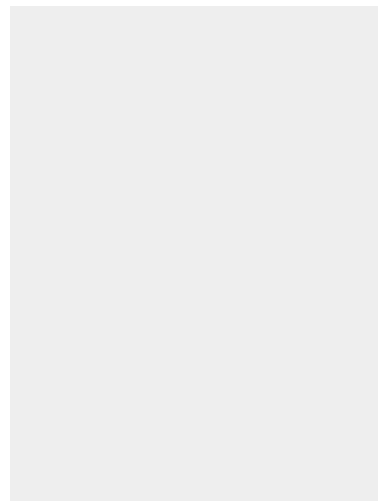

## Crimp contacts

## Crimp contacts 9A

9A



NO.	Wire gauge(mm <sup>2</sup> )	Male	Order No.
①	0.03-0.34	M23-MC9G-0.34	101 031 210 2501
②	0.14-1.0	M23-MC9G-1.0	101 031 210 0801
NO.	Wire gauge(mm <sup>2</sup> )	Female	Order No.
①	0.03-0.34	M23-FC9G-0.34	101 031 220 2501
②	0.14-1.0	M23-FC9G-1.0	101 031 220 0801

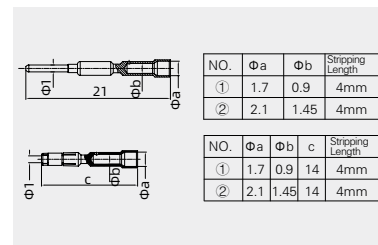

## Tools

## Crimping tool



Wire gauge	Designation	Order No.
0.14-4 mm <sup>2</sup>	TL28-2	198 001 001 0039

Notes: The tools for crimp terminal may influence the product quality and stability. Please select the tools recognized by our company.

Accessories

Stamped contacts

Stamped contacts



NO.	Wire gauge(mm <sup>2</sup> )	Male	Order No.
①	0.08-0.2	M23-MC9G-0.2P	101 031 210 0150
②	0.2-0.52	M23-MC9G-0.52P	101 031 210 0550
③	0.75-1.0	M23-MC9G-1.0P	101 031 210 0850
NO.	Wire gauge(mm <sup>2</sup> )	Female	Order No.
①	0.08-0.2	M23-FC9G-0.2P	101 031 220 0150
②	0.2-0.52	M23-FC9G-0.52P	101 031 220 0550
③	0.75-1.0	M23-FC9G-1.0P	101 031 220 0850

coil stock



Note: 10kpcs/volume

Tools

Terminal stamping machir



Wire gauge	Designation	Order No.
	M23-XC9G-MJ	903 020 000 0548

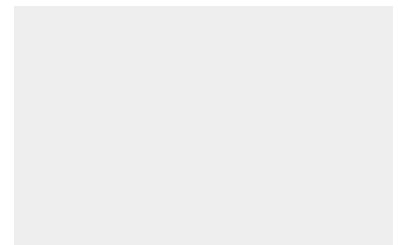
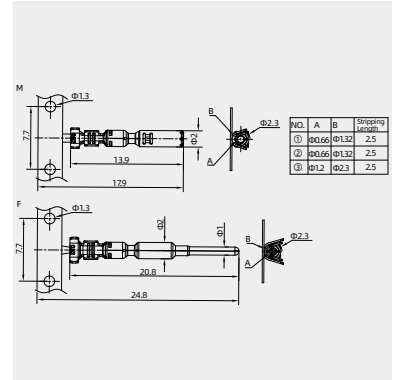



## MR23 Circular connector

63V- 7A

## Technical characteristics

Specifications			
Specifications	DIN EN 60 664		
	DIN EN 61 984		
Approvals			
Electrical data		Mechanical data	
Number of contacts	19(16+3)	Housing material	copper alloy,zinc alloy
signal:	0.03-1.0 mm <sup>2</sup> / AWG 32-18	Housing surface	Nickel-plated
power:	0.14-1.5 mm <sup>2</sup> / AWG 20-16	Contact resistance	≤ 5 mΩ
Rated current	7A	Insulating bodies	PBT
Rated voltage	63 V	Contact material	copper alloy
Rated impulse voltage	1.5 kV	Contact surface	gold plated
Pollution degree	3	Mechanical working life	>500
Flammability acc. to UL 94	V0 (UL94)	Degree of protection	IP67
Overvoltage categorie	III	Limiting temperature	-40°C ...+130°C

Forward coding, Crimp terminal  
order crimp contacts separately

Contacts	Designation	Order No.
19	MR23-019-BK-M20	181 019 300 1011

Reverse coding, Crimp terminal  
order crimp contacts separately

Contacts	Designation	Order No.
19	MR23-019R-BK-M20	181 019 300 1012

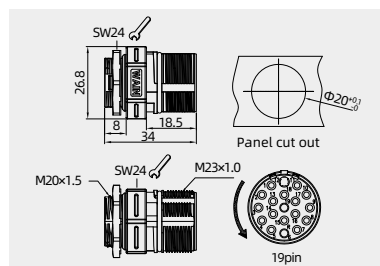
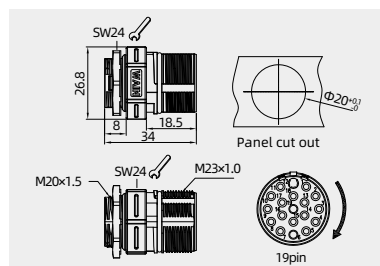
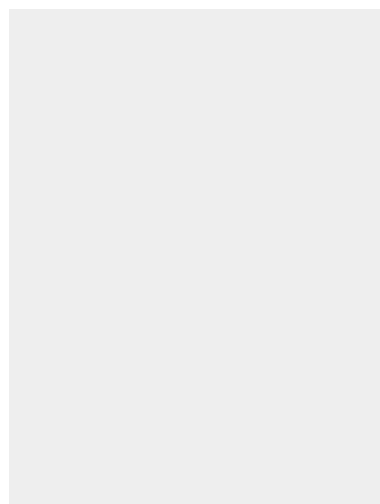

## Crimp contacts

## Crimp contacts 9A/7A

9A(signal)



7A(power)



9A(signal)



7A(power)



NO.	Wire gauge(mm <sup>2</sup> )	Male	Order No.
①	0.03-0.34	M23-MC9G-0.34	101 031 210 2501
②	0.14-1.0	M23-MC9G-1.0	101 031 210 0801
③	0.14-1.4	MR23-MC7G-1.0	101 015 210 0801
④	0.5-1.5	MR23-MC7G-1.5	101 015 210 0901
NO.	Wire gauge(mm <sup>2</sup> )	Female	Order No.
①	0.03-0.34	M23-FC9G-0.34	101 031 220 2501
②	0.14-1.0	M23-FC9G-1.0	101 031 220 0801
③	0.14-1.4	MR23-FC7G-1.0	101 015 220 0801
④	0.5-1.5	MR23-FC7G-1.5	101 015 220 0901

NO.	$\Phi a$	$\Phi b$	C	Stripping Length
①	1.7	0.9	21	4mm
②	2.1	1.45	21	4mm
③	2.1	1.45	20.65	6mm
④	2.1	1.75	20.65	6mm

NO.	$\Phi a$	$\Phi b$	C	Stripping Length
①	1.7	0.9	14	4mm
②	2.1	1.45	14	4mm
③	2.1	1.45	13.9	6mm
④	2.1	1.75	13.9	6mm

## Tools

Crimping tool



Wire gauge	Designation	Order No.
0.14-4 mm <sup>2</sup>	TL28-2	198 001 001 0039

Notes: The tools for crimp terminal may influence the product quality and stability. Please select the tools recognized by our company.

Accessories

Stamped contacts

Stamped contacts



NO.	Wire gauge(mm <sup>2</sup> )	Male	Order No.
①	0.08-0.2	M23-MC9G-0.2P	101 031 210 0150
②	0.2-0.52	M23-MC9G-0.52P	101 031 210 0550
③	0.75-1.0	M23-MC9G-1.0P	101 031 210 0850
NO.	Wire gauge(mm <sup>2</sup> )	Female	Order No.
①	0.08-0.2	M23-FC9G-0.2P	101 031 220 0150
②	0.2-0.52	M23-FC9G-0.52P	101 031 220 0550
③	0.75-1.0	M23-FC9G-1.0P	101 031 220 0850

coil stock



Note: 10kpcs/volume

Tools

Terminal stamping machin



Wire gauge	Designation	Order No.
	M23-XC9G-MJ	903 020 000 0548

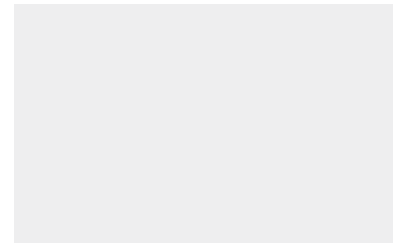
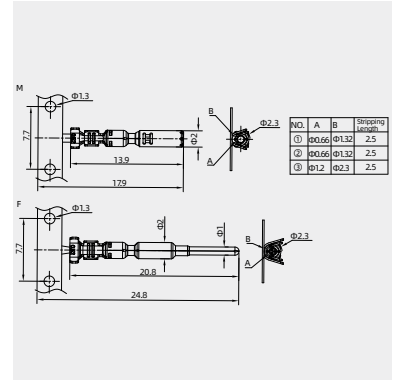

## MR23 Circular connector

## Fixed plate

Technical characteristics	
Pollution degree	3
Connector locking system	screw M3, M4
Limiting temperature	-20°C ...+130°C
Material of housing	zinc alloy

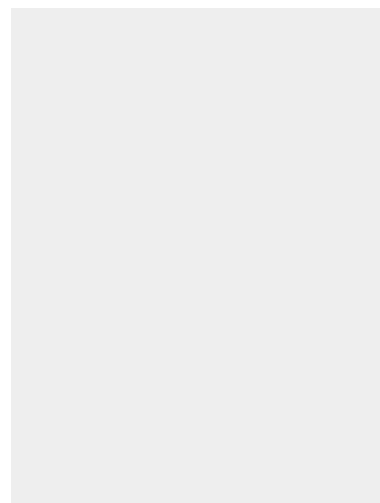

## Fixed plate



Describe	Designation	Order No.
immobilization	MR23-BK35-Φ24.5	181 000 000 1500

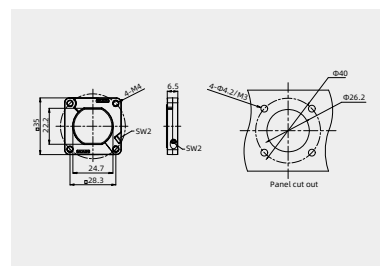

## MR23 Circular connector

- Operating Instruction(MR23-0XX-T-DXX-SH)

- Installation Step

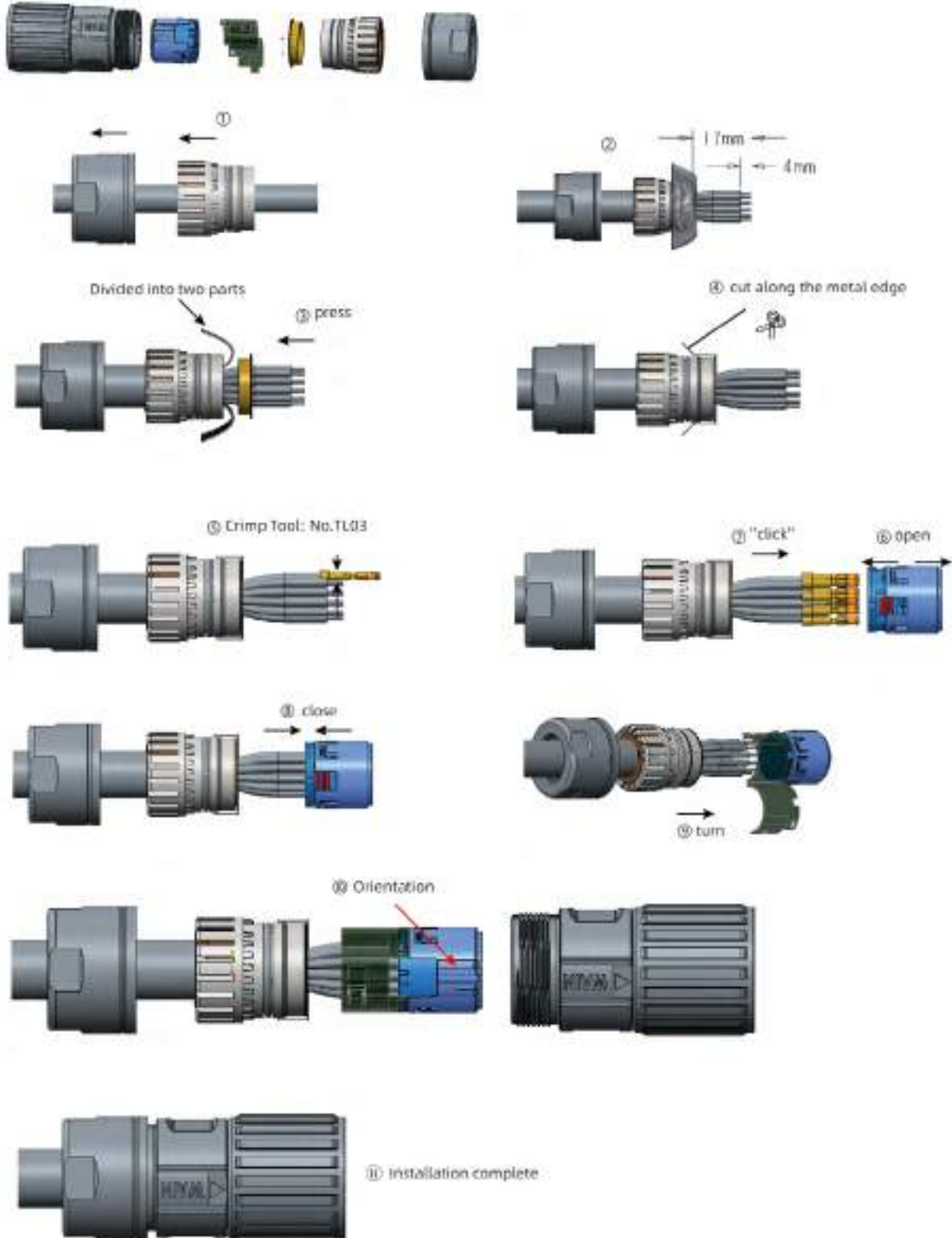

MR23 Circular connector

- Operating Instruction(MR23-0XX-BKP26-SE)

• Installation Step

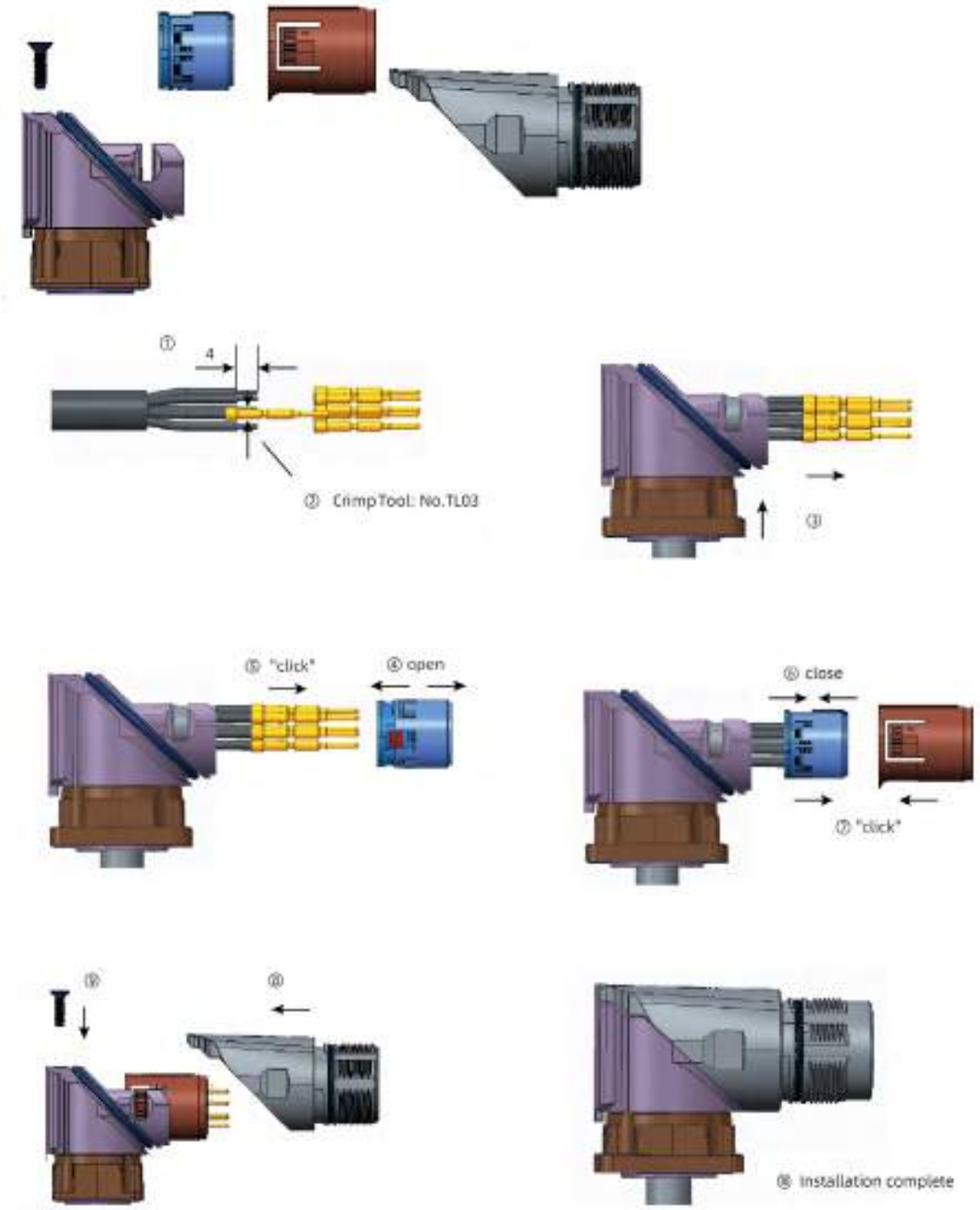

• Operating Instruction(MR23-0XX-BK26-OD3.2/2.7)

• Installation Step

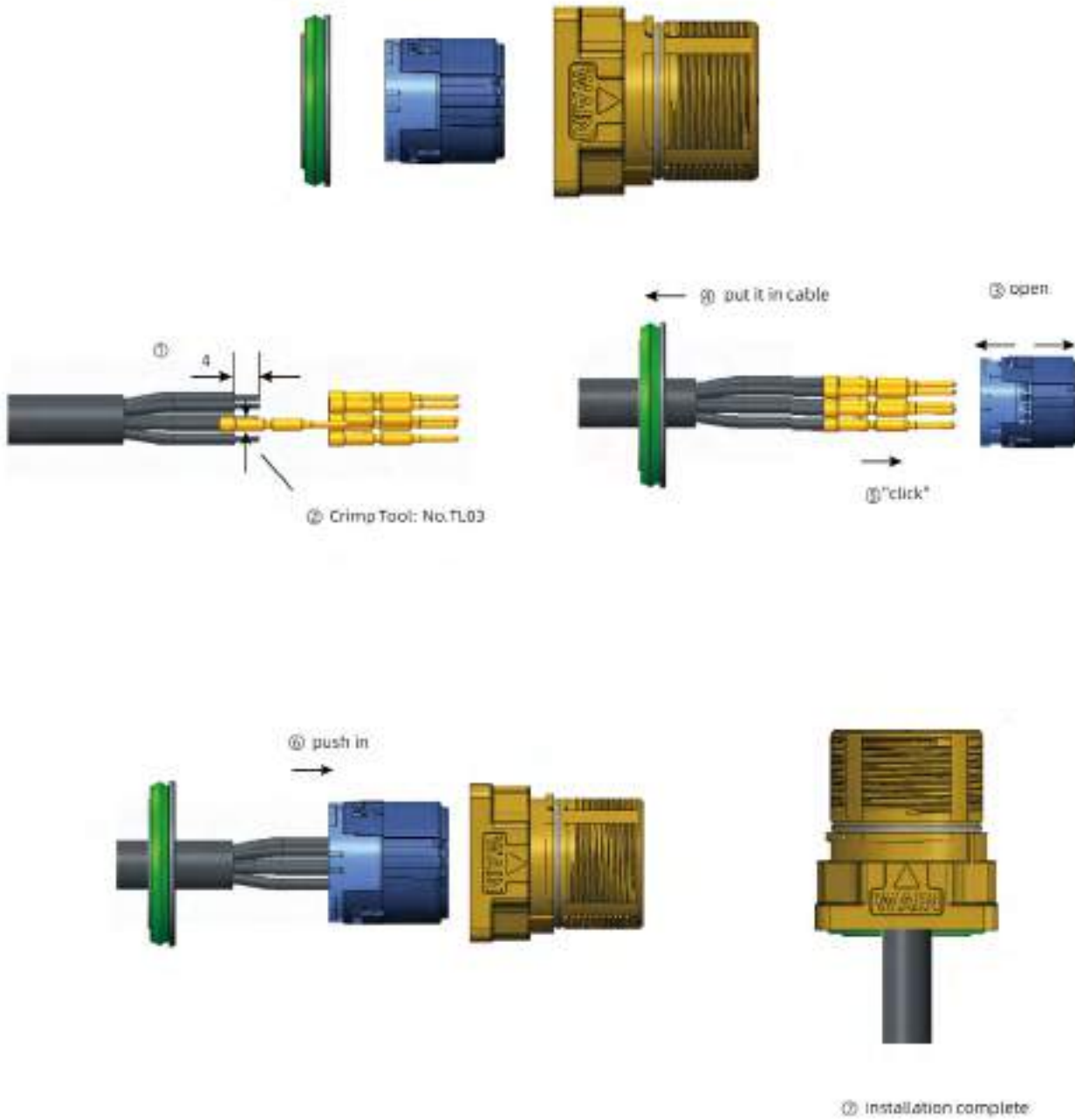



## M23 Circular power connectors

M23





## Circular Connector M23

630/250V 30/9A

## Technical characteristics

Specifications			
Specifications	DIN EN 60 664 DIN EN 61 984		
Approvals			
Electrical data	Mechanical data		
Number of contacts	1	Housing material	CuZn,Zinc(GD-Zn)
Contacts	-	Housing surface	Nickel-plated
ContactsΦ(mm)	-	Insulating bodies	Polyamide
mm <sup>2</sup> /AWG		Contact material	copper alloy
Rated current(25°C)	30	Contact surface	gold plated
Rated voltage	630	Terminal	Crimp version
Test voltage Urms (AC)	6kV	Gasket and O ring	Fluorine rubber
Overvoltage categorie	III	Ambient temperature	-40°C ...+130°C
Pollution degree	3	Cable outlet	4.2-17mm shielded
		Connector locking system	M23screw
		Mechanical operation	> 500
		Degree of protection	IP67

## Male, Crimp terminal

order crimp contacts separately

Contacts	Cable outlet	Designation	Order No.
1	4.2-6.6mm	M23-MC01-CCT-D6.6-SH	166 001 410 2501
	7.5-12mm	M23-MC01-CCT-D12-SH	166 001 410 2502
	9.5-14.5mm	M23-MC01-CCT-D14.5-SH	166 001 410 2503
	14-17mm	M23-MC01-CCT-D17-SH	166 001 410 2500

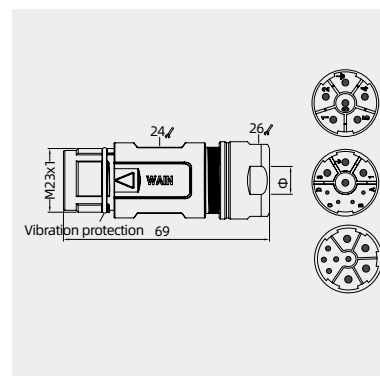

## Crimp contacts

No.	Wire gauge(mm <sup>2</sup> )	Male	Order No.
①	10mm <sup>2</sup>	M23-MC200S-10	101 027 110 1450
②	16mm <sup>2</sup>	M23-MC200S-16	101 027 110 1550
③	25mm <sup>2</sup>	M23-MC200S-25	101 027 110 1650
④	35mm <sup>2</sup>	M23-MC200S-35	101 027 110 1750
⑤	50mm <sup>2</sup>	M23-MC200S-50	101 027 110 1850

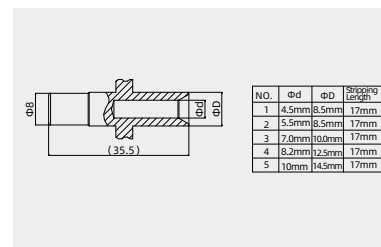

100A-650A

High current electro-hydraulic pliers



Wire gauge	Designation	Order No.
10-300 mm <sup>2</sup>	TL05-EA	198 001 001 0020

Notes: The tools for crimp terminal may influence the product quality and stability. Please select the tools recognized by our company.

## Circular Connector M23

630/250V 30/9A

## Technical characteristics

Specifications	
Specifications	DIN EN 60 664 DIN EN 61 984
Approvals	
Electrical data	
Number of contacts	1
Contacts	-
ContactsΦ(mm)	-
mm <sup>2</sup> /AWG	
Rated current(25°C)	30
Rated voltage	630
Test voltage Urms (AC)	6kV
Overvoltage categorie	III
Pollution degree	3
Mechanical data	
Housing material	CuZn,Zinc(GD-Zn)
Housing surface	Nickel-plated
Insulating bodies	Polyamide
Contact material	copper alloy
Contact surface	gold plated
Terminal	Crimp version
Gasket and O ring	Fluorine rubber
Ambient temperature	-40°C ...+130°C
Cable outlet	4.2-17mm shielded
Connector locking system	M23screw
Mechanical operation	> 500
Degree of protection	IP67

## Male, Crimp terminal

order crimp contacts separately



Contacts	Cable outlet	Designation	Order No.
1	4.2-6.6mm	M23-FC01-T-D6.6-SH	166 001 420 2502
	7.5-12mm	M23-FC01-T-D12-SH	166 001 420 2503
	9.5-14.5mm	M23-FC01-T-D14.5-SH	166 001 420 2504
	14-17mm	M23-FC01-T-D17-SH	166 001 420 2500

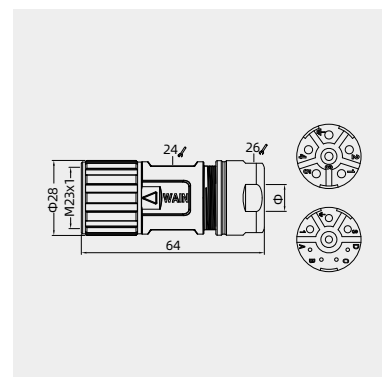

## Crimp contacts



No.	Wire gauge(mm <sup>2</sup> )	Female	Order No.
①	10mm <sup>2</sup>	M23-FC200S-10	101 027 120 1450
②	16mm <sup>2</sup>	M23-FC200S-16	101 027 120 1550
③	25mm <sup>2</sup>	M23-FC200S-25	101 027 120 1650
④	35mm <sup>2</sup>	M23-FC200S-35	101 027 120 1750
⑤	50mm <sup>2</sup>	M23-FC200S-50	101 027 120 1850

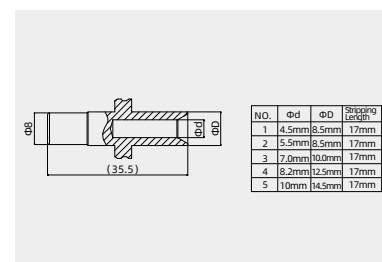

## 100A-650A

High current electro-hydraulic pliers



Wire gauge	Designation	Order No.
10-300 mm <sup>2</sup>	TL05-EA	198 001 001 0020

Notes: The tools for crimp terminal may influence the product quality and stability. Please select the tools recognized by our company.

## Circular Connector M23

630/250V 30/9A

## Technical characteristics

Specifications						Mechanical data		
Specifications	DIN EN 60 664 DIN EN 61 984					Housing material	CuZn,Zinc(GD-Zn)	
Approvals								
Electrical data						Mechanical data		
Number of contacts	6(5+PE)	8(4+3+PE)		9(5+3+PE)		Housing surface	Nickel-plated	
Contacts	5+PE	4	3+PE	5	3+PE	Insulating bodies	Polyamide	
ContactsΦ(mm)	2	1	2	1	2	Contact material	copper alloy	
mm <sup>2</sup> /AWG	0.35...4.0/22-12	0.03...1.5/32-16		0.35...4.0/22-12	0.14...1.5/26-16	0.35...4.0/22-12	Contact surface	gold plated
Rated current(25°C)	30	9	30	9	30	Terminal	Crimp version	
Rated voltage	630	250	630	250	630	Gasket and O ring	Fluorine rubber	
Test voltage Urms (AC)	6kV	4kV	6kV	4kV	6kV	Ambient temperature	-40°C ...+130°C	
Overvoltage categorie	III		III		III		Cable outlet	4.2-17mm shielded
Pollution degree	3		3		3		Connector locking system	M23screw
							Mechanical operation	> 500
							Degree of protection	IP67

## Male, Crimp terminal

order crimp contacts separately



Contacts	Cable outlet	Designation	Order No.
1	4.2-6.6mm	M23-MC01-CCT-D6.6-SH	166 001 410 2501
	7.5-12mm	M23-MC01-CCT-D12-SH	166 001 410 2502
	9.5-14.5mm	M23-MC01-CCT-D14.5-SH	166 001 410 2503
	14-17mm	M23-MC01-CCT-D17-SH	166 001 410 2500
(5+PE)	4.2-6.6mm	M23-MC06-TH-D6.6-SH	166 006 110 2007
	7.5-12mm	M23-MC06-TH-D12-SH	166 006 110 2001
	9.5-14.5mm	M23-MC06-TH-D14.5-SH	166 006 110 2002
	14-17mm	M23-MC06-TH-D17-SH	166 006 110 2003
8(4+3+PE)	4.2-6.6mm	M23-MC04/4-TH-D6.6-SH	166 008 110 2007
	7.5-12mm	M23-MC04/4-TH-D12-SH	166 008 110 2001
	9.5-14.5mm	M23-MC04/4-TH-D14.5-SH	166 008 110 2002
	14-17mm	M23-MC04/4-TH-D17-SH	166 008 110 2003
9(5+3+PE)	4.2-6.6mm	M23-MC04/5-TH-D6.6-SH	181 000 099 2502
	7.5-12mm	M23-MC04/5-TH-D12-SH	166 000 110 2500
	9.5-14.5mm	M23-MC04/5-TH-D14.5-SH	181 000 099 2503
	14-17mm	M23-MC04/5-TH-D17-SH	181 000 099 2504

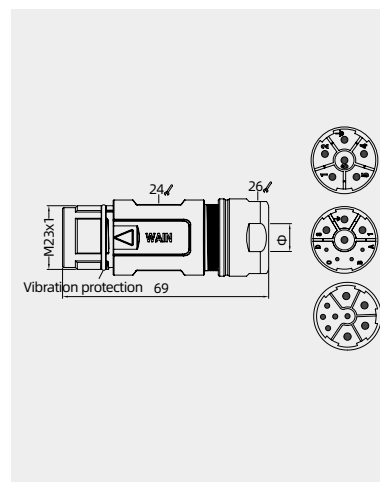

## Crimp contacts

Crimp contacts 9A/30A

9A



No.	Wire gauge(mm <sup>2</sup> )	Male	Order No.
①	0.14-1.0	M23-MCL9G-1.0	101 031 210 0802
②	0.5-1.5	M23-MCL9G-1.5	101 031 210 0902

30A



③	0.35-2.5	M23-MCL30G-2.5	101 031 210 1002
④	2.5-4.0	M23-MCL30G-4.0	101 031 210 1202

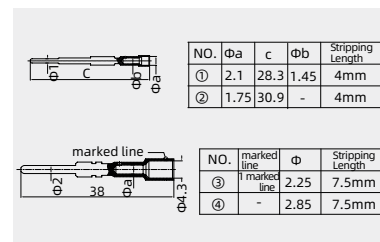

Tools

Crimping tool



Wire gauge	Designation	Order No.
0.14-4 mm <sup>2</sup>	TL28-2	198 001 001 0039

Notes: The tools for crimp terminal may influence the product quality and stability. Please select the tools recognized by our company.

## Circular Connector M23

630/250V 30/9A

## Technical characteristics

Specifications						Mechanical data	
Specifications	DIN EN 60 664 DIN EN 61 984					Housing material	CuZn,Zinc(GD-Zn)
Approvals							
Electrical data						Mechanical data	
Number of contacts	6(5+PE)	8(4+3+PE)		9(5+3+PE)		Housing surface	Nickel-plated
Contacts	5+PE	4	3+PE	5	3+PE	Insulating bodies	Polyamide
ContactsΦ(mm)	2	1	2	1	2	Contact material	copper alloy
mm <sup>2</sup> /AWG	0.35...4.0/22-12	0.03...1.5/32-16	0.35...4.0/22-12	0.14...1.5/26-16	0.35...4.0/22-12	Contact surface	gold plated
Rated current(25°C)	30	9	30	9	30	Terminal	Crimp version
Rated voltage	630	250	630	250	630	Gasket and O ring	Fluorine rubber
Test voltage Urms (AC)	6kV	4kV	6kV	4kV	6kV	Ambient temperature	-40°C ...+130°C
Overvoltage categorie	III		III		III	Cable outlet	4.2-17mm shielded
Pollution degree	3		3		3	Connector locking system	M23screw
						Mechanical operation	> 500
						Degree of protection	IP67

## Male, Crimp terminal

order crimp contacts separately



Contacts	Cable outlet	Designation	Order No.
6(5+PE)	4.2-6.6mm	M23-MC06-CCT/R-D6.6-SH	166 006 110 2007
	7.5-12mm	M23-MC06-CCT/R-D12-SH	166 006 110 2001
	9.5-14.5mm	M23-MC06-CCT/R-D14.5-SH	166 006 110 2002
	14-17mm	M23-MC06-CCT/R-D17-SH	166 006 110 2003
8(4+3+PE)	4.2-6.6mm	M23-MC04/4-CCT/R-D6.6-SH	166 008 110 2007
	7.5-12mm	M23-MC04/4-CCT/R-D12-SH	166 008 110 2001
	9.5-14.5mm	M23-MC04/4-CCT/R-D14.5-SH	166 008 110 2002
	14-17mm	M23-MC04/4-CCT/R-D17-SH	166 008 110 2003
9(5+3+PE)	4.2-6.6mm	M23-MC04/5-CCT/R-D6.6-SH	181 000 099 2505
	7.5-12mm	M23-MC04/5-CCT/R-D12-SH	166 009 710 2500
	9.5-14.5mm	M23-MC04/5-CCT/R-D14.5-SH	181 000 099 2506
	14-17mm	M23-MC04/5-CCT/R-D17-SH	181 000 099 2507

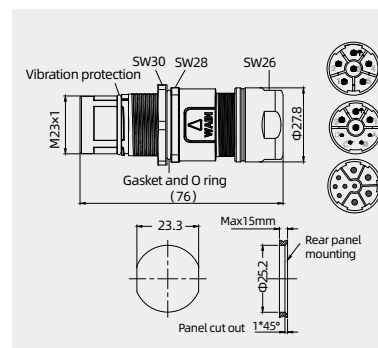

## Male, Crimp terminal

order crimp contacts separately



Contacts	Cable outlet	Designation	Order No.
6(5+PE)	4.2-6.6mm	M23-MC06-CCT/R28-D6.6-SH	166 006 110 2009
	7.5-12mm	M23-MC06-CCT/R28-D12-SH	166 006 710 2007
	9.5-14.5mm	M23-MC06-CCT/R28-D14.5-SH	166 006 710 2008
	14-17mm	M23-MC06-CCT/R28-D17-SH	166 006 710 2001
8(4+3+PE)	4.2-6.6mm	M23-MC04/4-CCT/R28-D6.6-SH	166 008 110 2009
	7.5-12mm	M23-MC04/4-CCT/R28-D12-SH	166 008 710 2007
	9.5-14.5mm	M23-MC04/4-CCT/R28-D14.5-SH	166 008 710 2008
	14-17mm	M23-MC04/4-CCT/R28-D17-SH	166 008 710 2002
9(5+3+PE)	4.2-6.6mm	M23-MC04/5-CCT/R28-D6.6-SH	181 000 099 2508
	7.5-12mm	M23-MC04/5-CCT/R28-D12-SH	166 000 799 2500
	9.5-14.5mm	M23-MC04/5-CCT/R28-D14.5-SH	166 000 799 2501
	14-17mm	M23-MC04/5-CCT/R28-D17-SH	166 000 799 2502

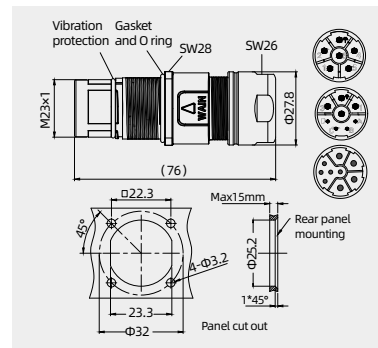

## Crimp contacts

Crimp contacts 9A/30A

9A



No.	Wire gauge(mm <sup>2</sup> )	Male	Order No.
①	0.14-1.0	M23-MCL9G-1.0	101 031 210 0802
②	0.5-1.5	M23-MCL9G-1.5	101 031 210 0902
③	0.35-2.5	M23-MCL30G-2.5	101 031 210 1002
④	2.5-4.0	M23-MCL30G-4.0	101 031 210 1202

30A



NO.	Φa	c	Φb	Stripping Length
①	2.1	28.3	1.45	4mm
②	1.75	30.9	-	4mm

NO.	marked line	Φ	Stripping Length
③	marked line	2.25	7.5mm
④	-	2.85	7.5mm

## Tools

Crimping tool



Wire gauge	Designation	Order No.
0.14-4 mm <sup>2</sup>	TL28-2	198 001 001 0039

Notes: The tools for crimp terminal may influence the product quality and stability. Please select the tools recognized by our company.

## Circular Connector M23

630/250V 30/9A

## Technical characteristics

## Specifications

Specifications	DIN EN 60 664
	DIN EN 61 984

## Approvals

## Electrical data

Number of contacts	6(5+PE)		8(4+3+PE)		9(5+3+PE)	
Contacts	5+PE	4	3+PE	5	3+PE	
ContactsΦ(mm)	2	1	2	1	2	
mm <sup>2</sup> /AWG	0.35...4.0/22-12	0.03...1.5/32-16	0.35...4.0/22-12	0.14...1.5/26-16	0.35...4.0/22-12	
Rated current(25°C)	30	9	30	9	30	
Rated voltage	630	250	630	250	630	
Test voltage Urms (AC)	6kV	4kV	6kV	4kV	6kV	
Overvoltage categorie	III		III		III	
Pollution degree	3		3		3	

## Mechanical data

Housing material	CuZn,Zinc(GD-Zn)
Housing surface	Nickel-plated
Insulating bodies	Polyamide
Contact material	copper alloy
Contact surface	gold plated
Terminal	Crimp version
Gasket and O ring	Fluorine rubber
Ambient temperature	-40°C ...+130°C
Cable outlet	4.2-17mm shielded
Connector locking system	M23screw
Mechanical operation	> 500
Degree of protection	IP67

## Female, Crimp terminal

order crimp contacts separately



Contacts	Cable outlet	Designation	Order No.
6(5+PE)	4.2-6.6mm	M23-FC06-T-D6.6-SH	166 006 420 2007
	7.5-12mm	M23-FC06-T-D12-SH	166 006 420 2001
	9.5-14.5mm	M23-FC06-T-D14.5-SH	166 006 420 2002
	14-17mm	M23-FC06-T-D17-SH	166 006 420 2003
8(4+3+PE)	4.2-6.6mm	M23-FC04/4-T-D6.6-SH	166 008 120 2004
	7.5-12mm	M23-FC04/4-T-D12-SH	166 008 420 2001
	9.5-14.5mm	M23-FC04/4-T-D14.5-SH	166 008 420 2002
	14-17mm	M23-FC04/4-T-D17-SH	166 008 420 2003

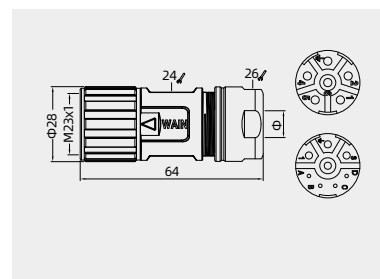

## Female, Crimp terminal

order crimp contacts separately

Recommended use



Contacts	Cable outlet	Designation	Order No.
6(5+PE)	4.2-6.6mm	M23-FC06-TH-D6.6-SH	166 006 420 2008
	7.5-12mm	M23-FC06-TH-D12-SH	166 006 120 2001
	9.5-14.5mm	M23-FC06-TH-D14.5-SH	166 006 120 2002
	14-17mm	M23-FC06-TH-D17-SH	166 006 120 2003
8(4+3+PE)	4.2-6.6mm	M23-FC04/4-TH-D6.6-SH	166 008 120 2005
	7.5-12mm	M23-FC04/4-TH-D12-SH	166 008 120 2001
	9.5-14.5mm	M23-FC04/4-TH-D14.5-SH	166 008 120 2002
	14-17mm	M23-FC04/4-TH-D17-SH	166 008 120 2003
9(5+3+PE)	4.2-6.6mm	M23-FC04/5-TH-D6.6-SH	166 000 199 0500
	7.5-12mm	M23-FC04/5-TH-D12-SH	166 009 420 2001
	9.5-14.5mm	M23-FC04/5-TH-D14.5-SH	166 000 199 2500
	14-17mm	M23-FC04/5-TH-D17-SH	166 009 120 2500

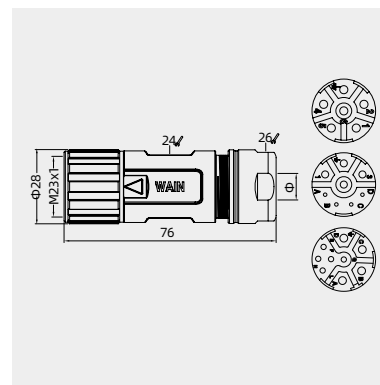

## Crimp contacts

## Crimp contacts 9A/30A

9A



No.	Wire gauge(mm <sup>2</sup> )	Female	Order No.
①	0.03-0.34	M23-FC9G-0.34	101 031 220 2501
②	0.14-1.0	M23-FC9G-1.0	101 031 220 0801
③	0.5-1.5	M23-FC9G-1.5	101 031 220 0901

30A



④	0.35-2.5	M23-FC30G-2.5	101 032 220 1001
⑤	2.5-4.0	M23-FC30G-4.0	101 032 220 1201

NO.	Φa	Φb	c	Stripping Length
①	1.7	0.9	14	4mm
②	2.1	1.45	14	4mm
③	1.75	-	16.7	4.9mm

NO.	marked line	Φ	Stripping Length
④	marked line	2.25	7.5mm
⑤	-	2.85	7.5mm

## Tools

Crimping tool



Wire gauge	Designation	Order No.
0.14-4 mm <sup>2</sup>	TL28-2	198 001 001 0039

Notes: The tools for crimp terminal may influence the product quality and stability. Please select the tools recognized by our company.

## Accessories

### Stamped contacts

#### 9G/30G Stamped contacts

9G



30G



NO.	Wire gauge(mm <sup>2</sup> )	Female	Order No.
①	0.08-0.2	M23-FC9G-0.2P	101 031 220 0150
②	0.2-0.52	M23-FC9G-0.52P	101 031 220 0550
③	0.75-1.0	M23-FC9G-1.0P	101 031 220 0850
①	0.5-2.5	M23-FC30G-2.5P	101 031 220 0150
②	2.5-4.0	M23-FC30G-4.0P	101 031 220 0550

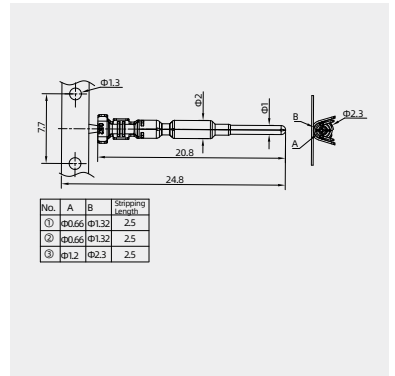

M23

coil stock



Note: 10kpcs/volume

#### Tools

Terminal stamping machine



Wire gauge	Designation	Order No.
	M23-XC9G-MJ	903 020 000 0548
	M23-XC30G-MJ	903 020 000 0549

## Circular Connector M23

630/250V 30/9A

## Technical characteristics

Specifications				
Specifications	DIN EN 60 664			
	DIN EN 61 984			
Approvals				
Electrical data		Mechanical data		
Number of contacts	6(5+PE)      8(4+3+PE)	Housing material	CuZn,Zinc(GD-Zn)	
Contacts	5+PE      4      3+PE	Housing surface	Nickel-plated	
ContactsΦ(mm)	2      1      2	Insulating bodies	Polyamide	
mm <sup>2</sup> /AWG	0.1...4.0/28-12    0.03...1.0/32-18    0.1...4.0/28-12	Contact material	copper alloy	
Rated current(25°C)	30      9      30	Contact surface	gold plated	
Rated voltage	630      250      630	Terminal	Crimp version	
Test voltage Urms (AC)	6kV      4kV      6kV	Gasket and O ring	Fluorine rubber	
Overvoltage categorie	III      III	Ambient temperature	-40°C ...+130°C	
Pollution degree	3      3	Connector locking system	M23screw	
		Mechanical operation	> 500	
		Degree of protection	IP67	

## Male, Crimp terminal

order crimp contacts separately

Recommended use



Contacts	Designation	Order No.
6(5+PE)	M23-MC06-BK26	166 006 310 1001
8(4+3+PE)	M23-MC04/4-BK26	166 008 310 1001

## Male, Crimp terminal

order crimp contacts separately



Contacts	Designation	Order No.
6(5+PE)	M23-MC06-BK28	166 006 310 1002
8(4+3+PE)	M23-MC04/4-BK28	166 008 310 1002

## Crimp contacts

Crimp contacts 9A/30A

9A



No.	Wire gauge(mm <sup>2</sup> )	Male	Order No.
①	0.03-0.34	M23-MC9G-0.34	101 031 210 2501
②	0.14-1.0	M23-MC9G-1.0	101 031 210 0801

30A



③	0.1-0.5	M23-MC30G-0.5	101 032 210 0401
④	0.35-2.5	M23-MC30G-2.5	101 032 210 1001
⑤	2.5-4.0	M23-MC30G-4.0	101 032 210 1201

## Tools

Crimping tool



Wire gauge	Designation	Order No.
0.14-4 mm <sup>2</sup>	TL28-2	198 001 001 0039

Notes: The tools for crimp terminal may influence the product quality and stability.  
Please select the tools recognized by our company.

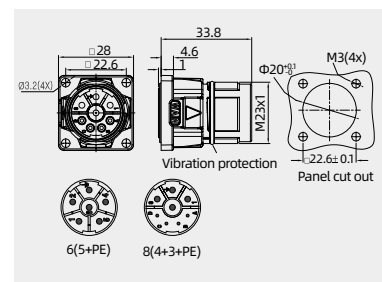
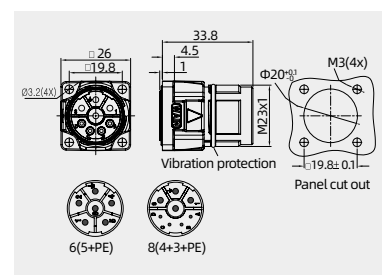
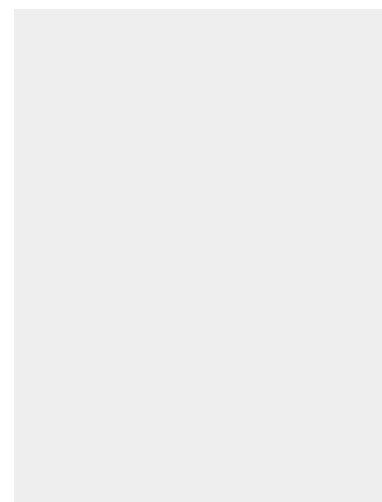

NO.	Φa	Φb	Stripping Length
①	1.7	0.9	4mm
②	2.1	1.45	4mm

NO.	Φa	Φb	c	Stripping Length
①	1.7	0.9	14	4mm
②	2.1	1.45	14	4mm
③	1.75	-	16.7	4.9mm

Accessories

Stamped contacts

Stamped contacts



No.	Wire gauge(mm <sup>2</sup> )	Female	Order No.
①	0.08-0.2	M23-MC9G-0.2P	101 031 210 0150
②	0.2-0.52	M23-MC9G-0.52P	101 031 210 0550
③	0.75-1.0	M23-MC9G-1.0P	101 031 210 0850

coil stock



M23

Note: 10kpcs/volume

Tools

Terminal stamping machine



Wire gauge	Designation	Order No.
	M23-XC9G-MJ	903 020 000 0548

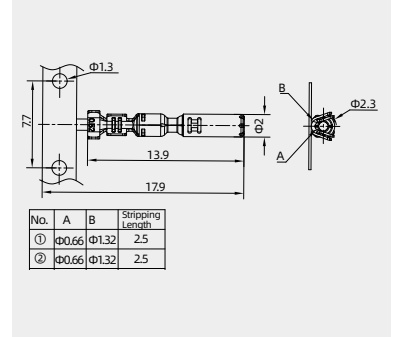



## Circular Connector M23

630/250V 30/9A

## Technical characteristics

Specifications				
Specifications	DIN EN 60 664			
	DIN EN 61 984			
Approvals				
Electrical data		Mechanical data		
Number of contacts	6(5+PE)	8(4+3+PE)	Housing material	CuZn,Zinc(GD-Zn)
Contacts	5+PE	4	3+PE	Housing surface
ContactsΦ(mm)	2	1	2	Insulating bodies
mm <sup>2</sup> /AWG	0.1...4.0/28-12	0.03...1.0/32-18	0.1...4.0/28-12	Contact material
Rated current(25°C)	30	9	30	Contact surface
Rated voltage	630	250	630	Terminal
Test voltage Urms (AC)	6kV	4kV	6kV	Gasket and O ring
Overvoltage categorie	III		III	Ambient temperature
Pollution degree	3		3	Connector locking system
				Mechanical operation
				Degree of protection

## Female, Crimp terminal

order crimp contacts separately



Contacts	Designation	Order No.
6(5+PE)	M23-FC06-BK26	166 006 320 1001
8(4+3+PE)	M23-FC04/4-BK26	166 008 020 1001

## Female, Crimp terminal

order crimp contacts separately



Contacts	Designation	Order No.
6(5+PE)	M23-FC06-BK28	166 006 320 1002
8(4+3+PE)	M23-FC04/4-BK28	166 008 020 1002

## Crimp contacts

Crimp contacts 9A/30A

9A



No.	Wire gauge(mm <sup>2</sup> )	Female	Order No.
①	0.03-0.34	M23-FC9G-0.34	101 031 220 2501
②	0.14-1.0	M23-FC9G-1.0	101 031 220 0801
③	0.5-1.5	M23-FC9G-1.5	101 031 220 0901

30A



④	0.35-2.5	M23-FC30G-2.5	101 032 220 1001
⑤	2.5-4.0	M23-FC30G-4.0	101 032 220 1201

## Tools

Crimping tool



Wire gauge	Designation	Order No.
0.14-4 mm <sup>2</sup>	TL28-2	198 001 001 0039

Notes: The tools for crimp terminal may influence the product quality and stability. Please select the tools recognized by our company.

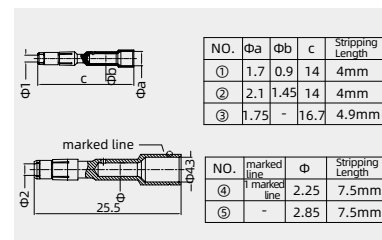
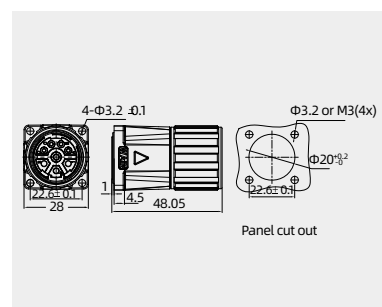
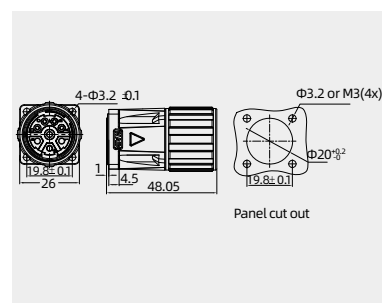
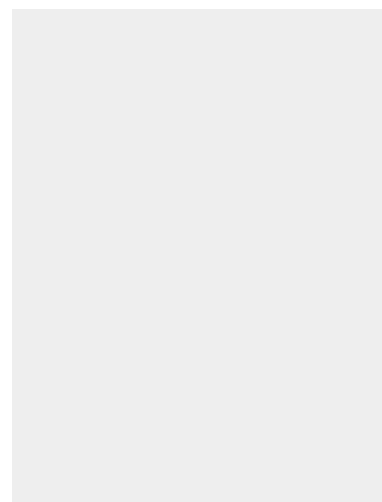

Accessories

Stamped contacts

9G/30G Stamped contacts

9G



30G



NO.	Wire gauge(mm <sup>2</sup> )	Female	Order No.
①	0.08-0.2	M23-FC9G-0.2P	101 031 220 0150
②	0.2-0.52	M23-FC9G-0.52P	101 031 220 0550
③	0.75-1.0	M23-FC9G-1.0P	101 031 220 0850
①	0.5-2.5	M23-FC30G-2.5P	101 031 220 0150
②	2.5-4.0	M23-FC30G-4.0P	101 031 220 0550

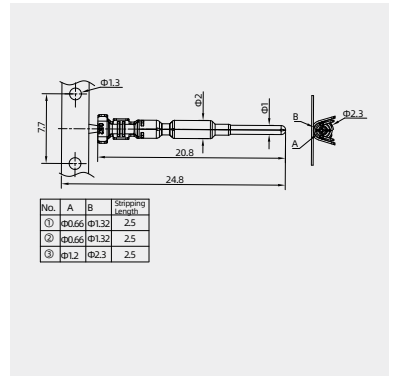

M23

coil stock



Note: 10kpcs/volume

Tools

Terminal stamping machine



Wire gauge	Designation	Order No.
	M23-XC9G-MJ	903 020 000 0548
	M23-XC30G-MJ	903 020 000 0549

## Circular Connector M23

630/250V 30/9A

## Technical characteristics

Specifications				
Specifications	DIN EN 60 664			
	DIN EN 61 984			
Approvals				
Electrical data		Mechanical data		
Number of contacts	6(5+PE)      8(4+3+PE)	Housing material	CuZn,Zinc(GD-Zn)	
Contacts	5+PE      4      3+PE	Housing surface	Nickel-plated	
ContactsΦ(mm)	2      1      2	Insulating bodies	Polyamide	
mm <sup>2</sup> /AWG	0.1...4.0/28-12    0.03...1.0/32-18    0.1...4.0/28-12	Contact material	copper alloy	
Rated current(25°C)	30      9      30	Contact surface	gold plated	
Rated voltage	630      250      630	Terminal	Crimp version	
Test voltage Urms (AC)	6kV      4kV      6kV	Gasket and O ring	Fluorine rubber	
Overvoltage categorie	III	Ambient temperature	-40°C ...+130°C	
Pollution degree	3	Connector locking system	M23screw	
		Mechanical operation	> 500	
		Degree of protection	IP67	

## Male, Crimp terminal

order crimp contacts separately

Elbow without rotated function

Recommended use use

Contacts	Designation	Order No.
6(5+PE)	M23-MC06-BK28-SE	166 006 610 1002
8(4+3+PE)	M23-MC04/4-BK28-SE	166 008 610 1002

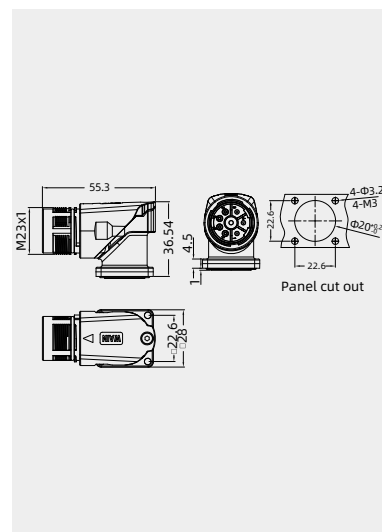
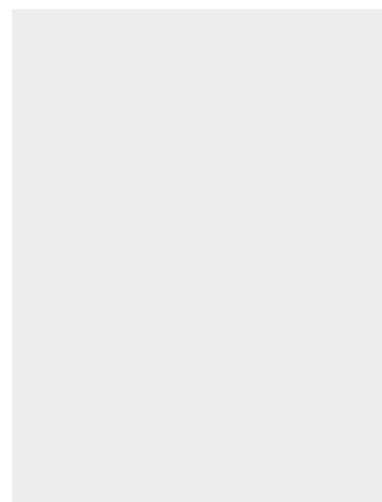

## Crimp contacts

Crimp contacts 9A/30A

	No.	Wire gauge(mm <sup>2</sup> )	Male	Order No.
9A	①	0.03-0.34	M23-MC9G-0.34	101 031 210 2501
	②	0.14-1.0	M23-MC9G-1.0	101 031 210 0801
30A	③	0.1-0.5	M23-MC30G-0.5	101 032 210 0401
	④	0.35-2.5	M23-MC30G-2.5	101 032 210 1001
	⑤	2.5-4.0	M23-MC30G-4.0	101 032 210 1201

NO.	Φa	Φb	Stripping Length
①	1.7	0.9	4mm
②	2.1	1.45	4mm

NO.	Φa	Φb	c	Stripping Length
①	1.7	0.9	14	4mm
②	2.1	1.45	14	4mm
③	1.75	-	16.7	4.9mm

## Tools

Crimping tool

Wire gauge	Designation	Order No.
0.14-4 mm <sup>2</sup>	TL28-2	198 001 001 0039



Notes: The tools for crimp terminal may influence the product quality and stability.  
Please select the tools recognized by our company.

Accessories

Stamped contacts

Stamped contacts



No.	Wire gauge(mm <sup>2</sup> )	Female	Order No.
①	0.08-0.2	M23-MC9G-0.2P	101 031 210 0150
②	0.2-0.52	M23-MC9G-0.52P	101 031 210 0550
③	0.75-1.0	M23-MC9G-1.0P	101 031 210 0850

coil stock



M23

Note: 10kpcs/volume

Tools

Terminal stamping machine



Wire gauge	Designation	Order No.
	M23-XC9G-MJ	903 020 000 0548

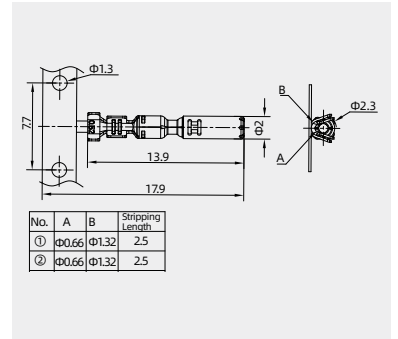

## Circular Connector M23

630/250V 30/9A

## Technical characteristics

Specifications					
Specifications	DIN EN 60 664				
	DIN EN 61 984				
Approvals					
Electrical data			Mechanical data		
Number of contacts	6(5+PE)	8(4+3+PE)		Housing material	CuZn,Zinc(GD-Zn)
Contacts	5+PE	4	3+PE	Housing surface	Nickel-plated
ContactsΦ(mm)	2	1	2	Insulating bodies	Polyamide
mm <sup>2</sup> /AWG	0.1...4.0/28-12	0.03...1.0/32-18	0.1...4.0/28-12	Contact material	copper alloy
Rated current(25°C)	30	9	30	Contact surface	gold plated
Rated voltage	630	250	630	Terminal	Crimp version
Test voltage Urms (AC)	6kV	4kV	6kV	Gasket and O ring	Fluorine rubber
Overvoltage categorie	III	III		Ambient temperature	-40°C ...+130°C
Pollution degree	3	3		Connector locking system	M23screw
				Mechanical operation	> 500
				Degree of protection	IP67

## Male, Crimp terminal

order crimp contacts separately  
Elbow with rotated function

Contacts	Designation	Order No.
6(5+PE)	M23-MC06-BKP26-SE-OD2.7	166 006 610 1003
8(4+3+PE)	M23-MC04/4-BKP26-SE-OD2.7	166 008 610 1011

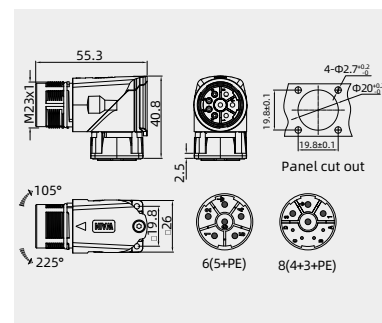

## Male, Crimp terminal

order crimp contacts separately  
Elbow with rotated function

Contacts	Designation	Order No.
6(5+PE)	M23-MC06-BKP28.8-SE	166 006 310 1003
8(4+3+PE)	M23-MC04/4-BKP28.8-SE	166 008 310 1003

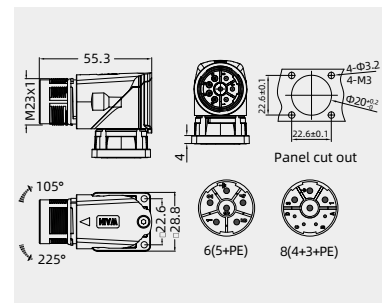

## Crimp contacts

## Crimp contacts 9A/30A



No.	Wire gauge(mm <sup>2</sup> )	Male	Order No.
①	0.03-0.34	M23-MC9G-0.34	101 031 210 2501
②	0.14-1.0	M23-MC9G-1.0	101 031 210 0801
③	0.1-0.5	M23-MC30G-0.5	101 032 210 0401
④	0.35-2.5	M23-MC30G-2.5	101 032 210 1001
⑤	2.5-4.0	M23-MC30G-4.0	101 032 210 1201

NO.	Φa	Φb	c	Stripping Length
②	2.1	1.45	14	4mm
③	1.75	-	16.7	4.9mm

## Tools

Crimping tool



Wire gauge	Designation	Order No.
0.14-4 mm <sup>2</sup>	TL28-2	198 001 001 0039

Notes: The tools for crimp terminal may influence the product quality and stability.  
Please select the tools recognized by our company.

Accessories

Stamped contacts

Stamped contacts



No.	Wire gauge(mm <sup>2</sup> )	Female	Order No.
①	0.08-0.2	M23-MC9G-0.2P	101 031 210 0150
②	0.2-0.52	M23-MC9G-0.52P	101 031 210 0550
③	0.75-1.0	M23-MC9G-1.0P	101 031 210 0850

coil stock



M23

Note: 10kpcs/volume

Tools

Terminal stamping machine



Wire gauge	Designation	Order No.
	M23-XC9G-MJ	903 020 000 0548

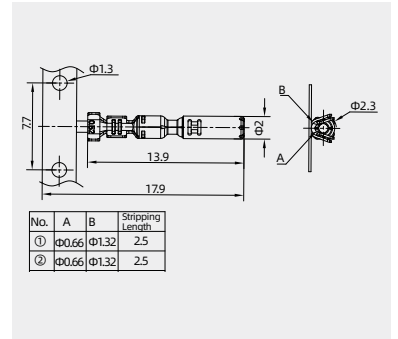

Accessories

Protection cap IP67

Protection covers  
for male cable connector



Description	Designation	Order No.
Black	M23-CV-F	266 000 000 9001
transparent	M23-CV-F3	166 000 000 9001

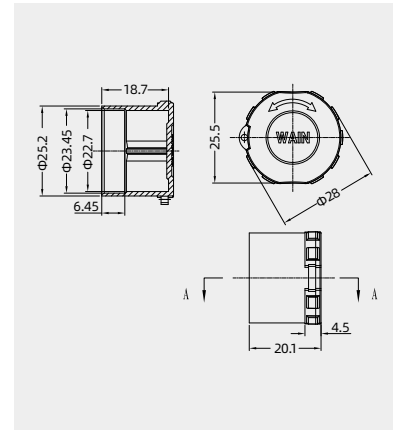

Fixed plate



Describe	Designation	Order No.
immobilization	M23-BK35-Φ27	166000001500

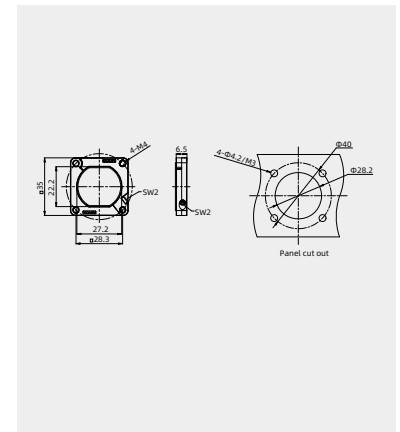

• Operating Instruction (Serie M23 Socket male)

• Installation Step

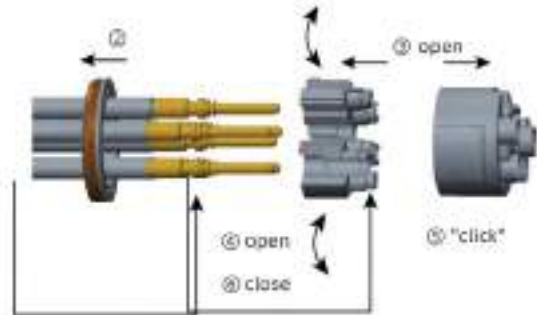
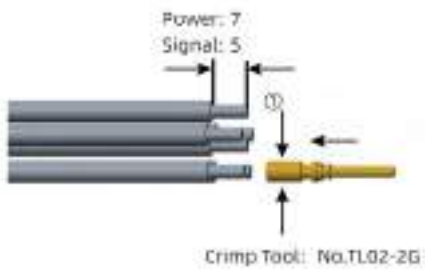

⑦ Installation complete





- Operating Instruction(Power Motor connector)

- Installation Step

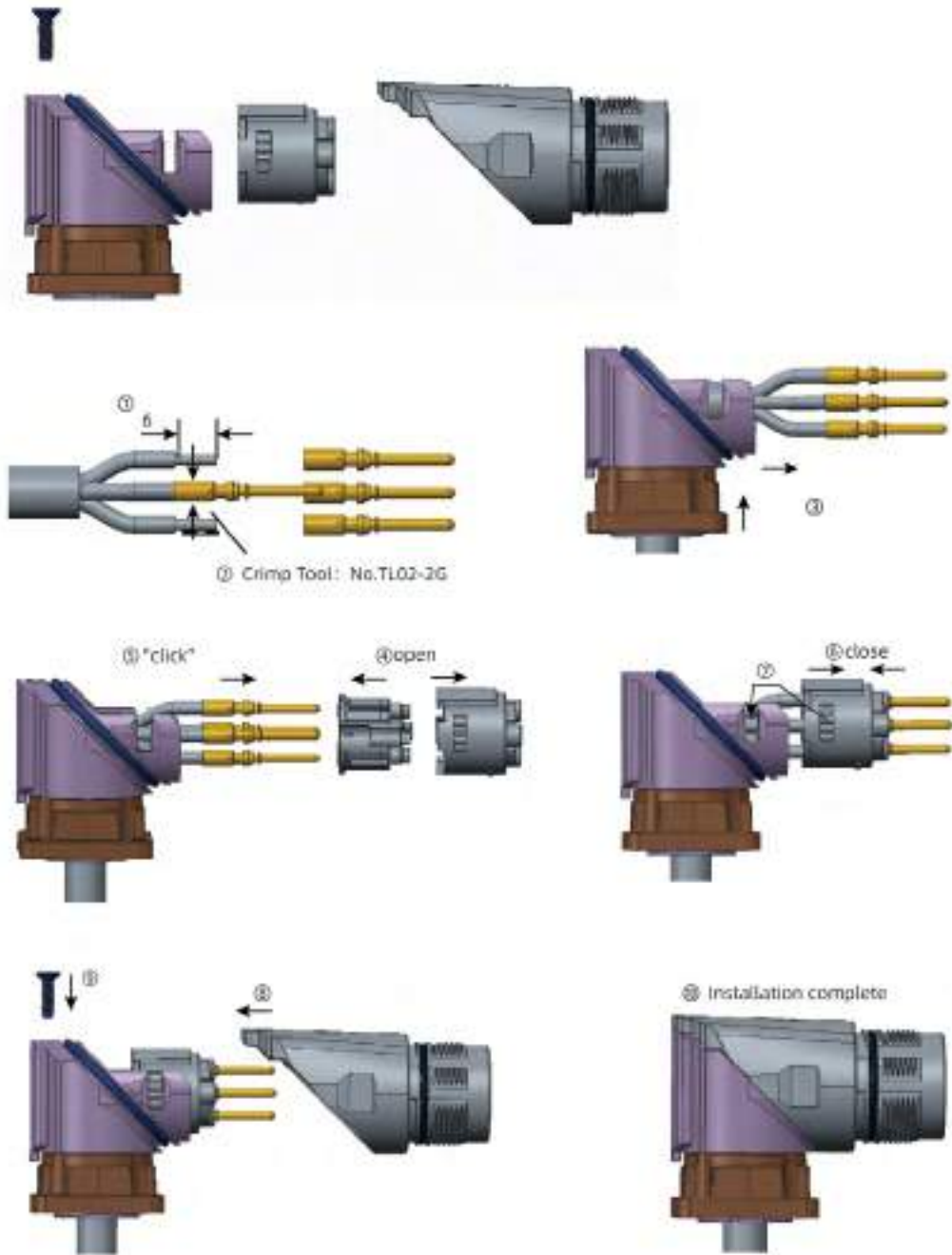

• Operating Instruction (Serie M23 Plug female)

• Installation Step

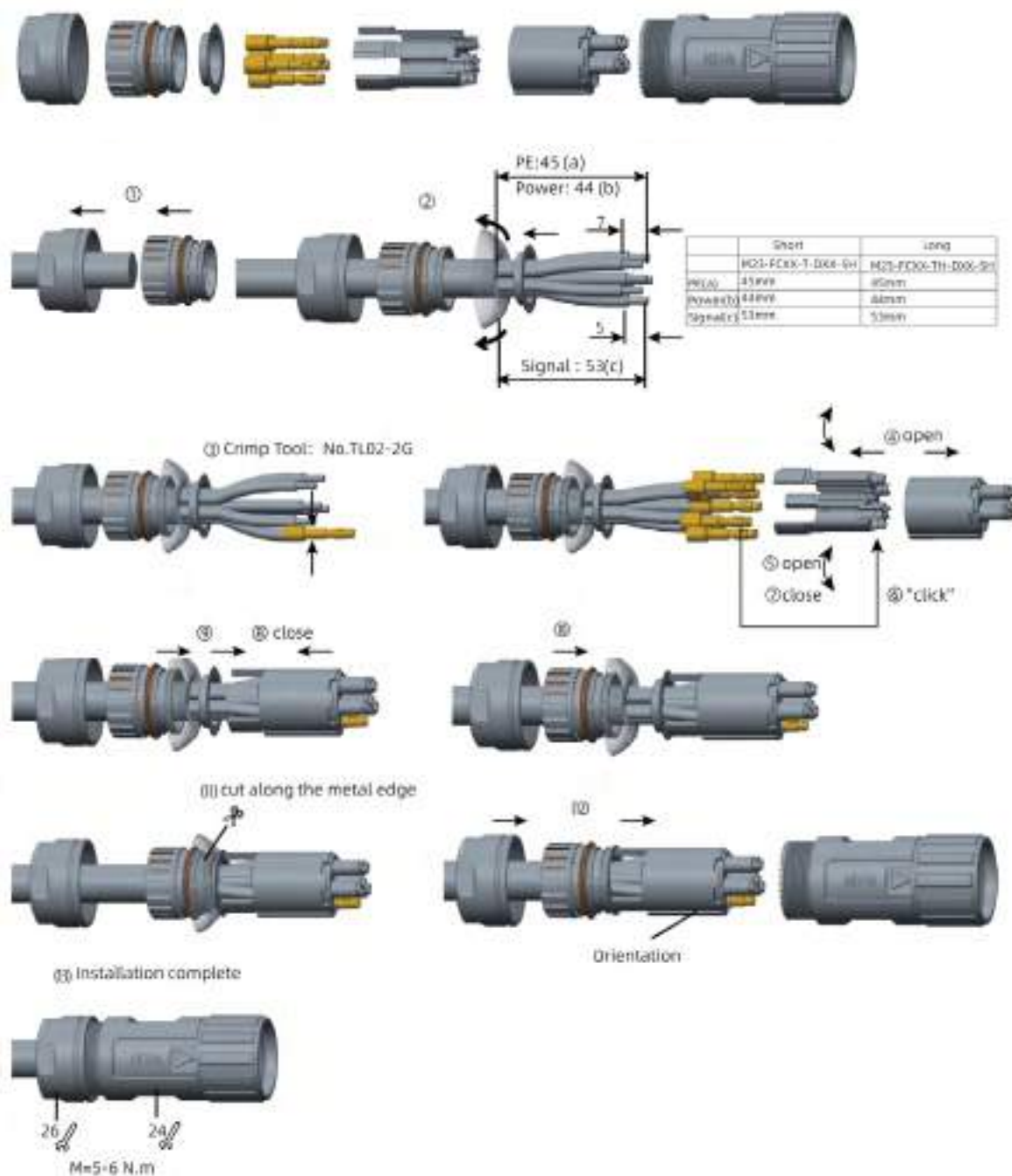



## M40 Circular power connectors



M40

## Circular Connector M40

250/630V 30/75A

## Technical characteristics

Specifications	
Specifications	DIN EN 60 664 DIN EN 61 984
Approvals	
Electrical data	
Number of contacts	4/2, 4/4, 4/5
Electrical properties	
-Rated current	75A (power) 30A (signal)
-Rated voltage	630V (power) 250V (signal)
-Rated impulse voltage	6000V (power) 4000V (signal)
-Contact resistance	$\phi 3.6$ (power): $\leq 1 \text{ m}\Omega$ $\phi 2$ (signal): $\leq 3 \text{ m}\Omega$
Material and finish	
-Housing material	copper alloyNickel-plated, zinc alloyNickel-plated
-contact	copper alloygold plated
-Insulating material	PA
-Sealing element	FKM
Mechanical properties	
-Mechanical working life	$\geq 500$ 次
-Lock mode	M40 $\times$ 1.5
-Cable and outlet diameter	$\phi 7$ - $\phi 25$
Environmental performance	
-Limiting temperature	-40°C ...+130°C
-Degree of protection	IP67
-Pollution degree	3

## Crimp terminal

Order crimp contacts separately



Contacts	Cable outlet	Designation	Order No.
6(5+PE)	7-9mm	M40-MC04/2-T-D9-SH	170 006 410 2002
	9-16mm	M40-MC04/2-T-D16-SH	170 006 410 2001
	16.5-25mm	M40-MC04/2-T-D25-SH	170 006 410 2003
7-9mm	7-9mm	M40-MC04/4-T-D9-SH	170 008 410 2001
	9-16mm	M40-MC04/4-T-D16-SH	170 008 430 2001
	16.5-25mm	M40-MC04/4-T-D25-SH	170 008 410 2003
7-9mm	7-9mm	M40-MC04/5-T-D9-SH	170 009 410 2001
	9-16mm	M40-MC04/5-T-D16-SH	170 009 410 2002
	16.5-25mm	M40-MC04/5-T-D25-SH	170 009 410 2003

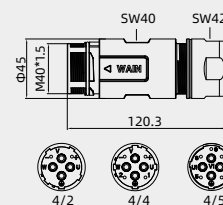

## Accessories

## 30A/75ACrimp contacts

signal



power



NO.	Wire gauge(mm <sup>2</sup> )	Male	Order No.
①	0.35-2.5	M40-MCL30G-2.5	101 032 210 1012
②	2.5-4.0	M40-MCL30G-4.0	101 032 210 1202
③	1.5-4/6-10	M40-MCL75G-10	101 034 210 1401
④	6-10/10-16	M40-MCL75G-16	101 034 210 1501

## Tools

Crimping tool



Wire gauge	Designation	Order No.
0.14-4mm <sup>2</sup>	TL28-2	198 001 001 0039
1.5-10mm <sup>2</sup>	TL28-3	198 001 001 0040

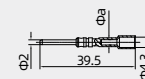

NO.	$\Phi a$	Stripping Length
①	$\Phi 2.25$	7 mm
②	$\Phi 2.85$	7 mm

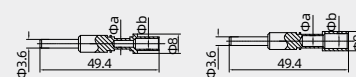

NO.	$\Phi a$	$\Phi b$	Stripping Length
③	$\Phi 2.85$	$\Phi 4.5$	9 mm
④	$\Phi 4.5$	$\Phi 6.1$	9 mm

Notes: The tools for crimp terminal may influence the product quality and stability. Please select the tools recognized by our company.

## Circular Connector M40

250/630V 30/75A

## Technical characteristics

Specifications			
Specifications	DIN EN 60 664		
	DIN EN 61 984		
Approvals			
Electrical data			
Number of contacts	4/2, 4/4, 4/5		
Electrical properties			
-Rated current	75A (power)		
	30A (signal)		
-Rated voltage	630V (power)		
	250V (signal)		
-Rated impulse voltage	6000V (power)		
	4000V (signal)		
-Contact resistance	$\phi 3.6$ (power): $\leq 1 \text{ m}\Omega$		
	$\phi 2$ (signal): $\leq 3 \text{ m}\Omega$		
Material and finish			
-Housing material	copper alloyNickel-plated, zinc alloyNickel-plated		
-contact	copper alloygold plated		
-Insulating material	PA		
-Sealing element	FKM		

M40

## Crimp terminal

Order crimp contacts separately



Insert	Cable outlet	Designation	Order No.
Female	7-9mm	M40-FC04/2-T-D9-SH	170 004 420 2005
	9-16mm	M40-FC04/2-T-D16-SH	170 004 420 2001
	16.5-25mm	M40-FC04/2-T-D25-SH	170 004 420 2004
	7-9mm	M40-FC04/4-T-D9-SH	170 008 420 2010
	9-16mm	M40-FC04/4-T-D16-SH	170 008 420 2004
	16.5-25mm	M40-FC04/4-T-D25-SH	170 008 420 2005
	7-9mm	M40-FC04/5-T-D9-SH	170 009 420 2007
	9-16mm	M40-FC04/5-T-D16-SH	170 009 420 2001
	16.5-25mm	M40-FC04/5-T-D25-SH	170 009 420 2006

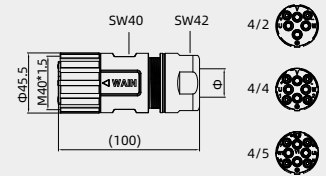

## Accessories

## Crimp contacts 30A/75A

signal



power



NO.	Wire gauge(mm <sup>2</sup> )	Female	Order No.
①	0.35-2.5	M23-FC30G-2.5	101 032 220 1001
②	2.5-4.0	M23-FC30G-4.0	101 032 220 1201
③	1.5-4/6-10	M40-FC75G-10	101 034 220 1401
④	6-10/10-16	M40-FC75G-16	101 024 220 1501

## Tools

Crimping tool



Wire gauge	Designation	Order No.
0.14-4mm <sup>2</sup>	TL28-2	198 001 001 0039
1.5-10mm <sup>2</sup>	TL28-3	198 001 001 0040

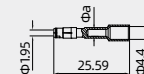

NO.	Φa	Stripping Length
①	Φ2.25	7 mm
②	Φ2.85	7 mm

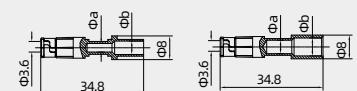

NO.	Φa	Φb	Stripping Length
③	Φ2.85	Φ4.5	9 mm
④	Φ4.5	Φ6.1	9 mm

Notes: The tools for crimp terminal may influence the product quality and stability. Please select the tools recognized by our company.

## Circular Connector M40

250/630V 30/65A

## Technical characteristics

Specifications			
Specifications	DIN EN 60 664 DIN EN 61 984		
Approvals			
Electrical data			
Number of contacts	4/2, 4/4, 4/5		
Electrical properties			
-Rated current	65A (power) 30A (signal)		
-Rated voltage	630V (power) 250V (signal)		
-Rated impulse voltage	6000V (power) 4000V (signal)		
-Contact resistance	$\phi 3.6$ (power): $\leq 1 \text{ m}\Omega$ $\phi 2$ (signal): $\leq 3 \text{ m}\Omega$		
Material and finish			
-Housing material	copper alloyNickel-plated, zinc alloyNickel-plated		
-contact	copper alloygold plated		
-Insulating material	PA		
-Sealing element	FKM		
Mechanical properties			
-Mechanical working life	$\geq 500$ 次		
-Lock mode	M40 $\times$ 1.5		
-Cable and outlet diameter	$\phi 22$		
Environmental performance			
-Limiting temperature	-40°C ...+130°C		
-Degree of protection	IP67		
-Pollution degree	3		

## Crimp terminal

order crimp contacts separately

Rotation type

After fixing, the angle can be rotated up to 320°.



Insert	Cable outlet	Designation	Order No.
Male	$\phi 22$	M40-MC04/2-BKP40-SE	170 006 410 1006
	$\phi 22$	M40-MC04/4-BKP40-SE	170 008 610 1002
	$\phi 22$	M40-MC04/5-BKP40-SE	170 009 610 3001

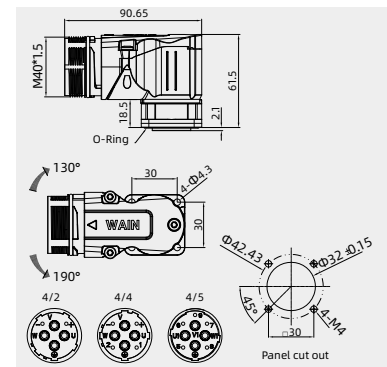
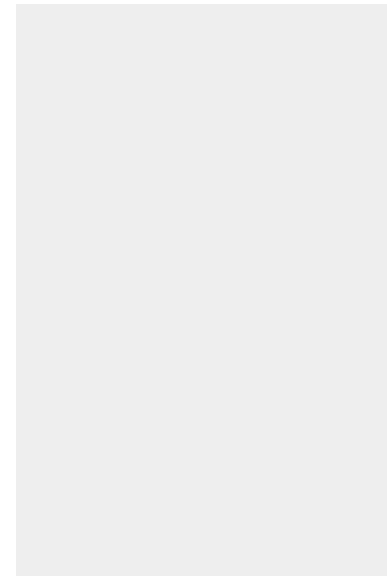

## Accessories

## Crimp contacts 30A/75A

signal



power



NO.	Wire gauge(mm <sup>2</sup> )	Male	Order No.
①	0.1-0.5	M40-MC30G-0.5	101 032 210 0402
②	0.35-2.5	M40-MC30G-2.5	101 032 210 1013
③	2.5-4.0	M40-MC30G-4.0	101 032 210 1203
④	1.5-4.0	M40-MC75G-4.0	101 034 210 1201
⑤	6-10	M40-MC75G-10	101 034 210 1402

## Tools

Crimping tool



Wire gauge	Designation	Order No.
0.14-4mm <sup>2</sup>	TL28-2	198 001 001 0039
1.5-10mm <sup>2</sup>	TL28-3	198 001 001 0040

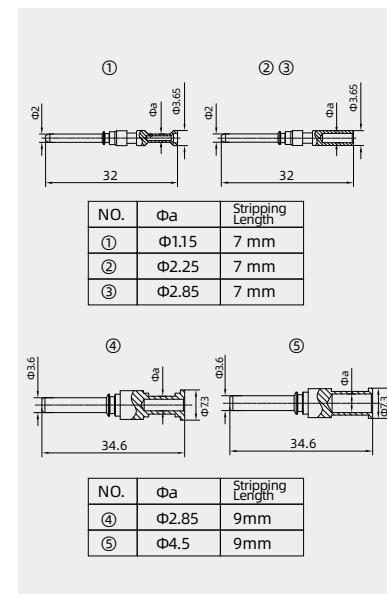

Notes: The tools for crimp terminal may influence the product quality and stability. Please select the tools recognized by our company.

## Circular Connector M40

250/630V 30/65A

## Technical characteristics

Specifications			
Specifications	DIN EN 60 664 DIN EN 61 984		
Approvals		Mechanical properties	
Electrical data		-Mechanical working life	≥ 500 次
Number of contacts	4/2、4/4、4/5	-Lock mode	M40×1.5
Electrical properties		Environmental performance	
-Rated current	65A (power) 30A (signal)	-Limiting temperature	-40°C ...+130°C
-Rated voltage	630V (power) 250V (signal)	-Degree of protection	IP67
-Rated impulse voltage	6000V (power) 4000V (signal)	-Pollution degree	3
-Contact resistance	φ3.6(power): ≤ 1 mΩ φ2 (signal): ≤ 3 mΩ		
Material and finish			
-Housing material	copper alloyNickel-plated、zinc alloyNickel-plated		
-contact	copper alloygold plated		
-Insulating material	PA		
-Sealing element	FKM		

## Crimp terminal

order crimp contacts separately  
Stationary type,Elbow without rotated  
function



Insert	Designation	Order No.
Male	M40-MC04/2-BK40	170 006 310 1001
	M40-MC04/4-BK40	170 008 310 3001
	M40-MC04/5-BK40	170 009 310 3001

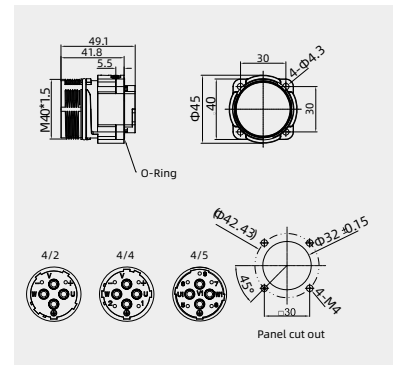
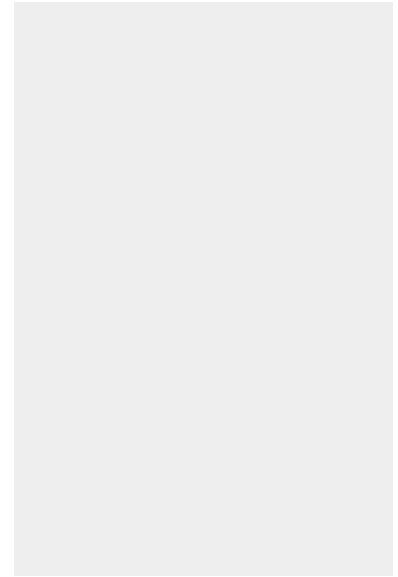

## Accessories

## Crimp terminal

signal



power contact



NO.	Wire gauge(mm <sup>2</sup> )	Male	Order No.
①	0.1-0.5	M40-MC30G-0.5	101 032 210 0402
②	0.35-2.5	M40-MC30G-2.5	101 032 210 1013
③	2.5-4.0	M40-MC30G-4.0	101 032 210 1203
④	1.5-4.0	M40-MC75G-4.0	101 034 210 1201
⑤	6-10	M40-MC75G-10	101 034 210 1402

## Tools

Crimping tool



Wire gauge	Designation	Order No.
0.14-4mm <sup>2</sup>	TL28-2	198 001 001 0039
1.5-10mm <sup>2</sup>	TL28-3	198 001 001 0040

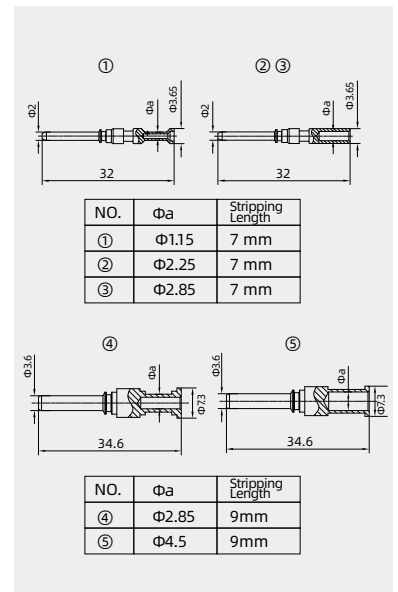

Notes: The tools for crimp terminal may influence the product quality and stability. Please select the tools recognized by our company.





## Circular Connector M40

250/630V 20/63A

## Technical characteristics

Specifications			
Specifications	DIN EN 60 664		
	DIN EN 61 984		
Approvals			
Electrical data		Mechanical properties	
Number of contacts	4/4	-Mechanical working life	≥ 500 次
Electrical properties		-Lock mode	Thread locking
-Rated current	63A (power)	-Cable and outlet diameter	φ19-21.5
	20A (signal)	Environmental performance	
-Rated voltage	630V (power)	-Limiting temperature	-40°C ...+130°C
	250V (signal)	-Degree of protection	IP67
-Rated impulse voltage	6000V (power)	-Pollution degree	3
	4000V (signal)		
-Contact resistance	φ3.6(power): ≤ 1 mΩ		
	φ2 (signal): ≤ 3 mΩ		
Material and finish			
-Housing material	copper alloyNickel-plated, zinc alloyNickel-plated		
-contact	copper alloygold plated		
-Insulating material	PA		
-Sealing element	FKM		

## Crimp terminal

order crimp contacts separately  
Stationary type,Elbow without rotated function



Insert	Designation	Order No.
Male	M40-MC04/4-BK-SE	170 008 610 1001

## Crimp terminal

order crimp contacts separately  
Rotation type  
After fixing, the angle can be rotated up to 320°.



Insert	Designation	Order No.
Male	M40-MC04/4-BKP-SE	170 008 610 1011

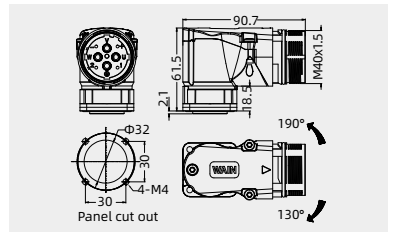
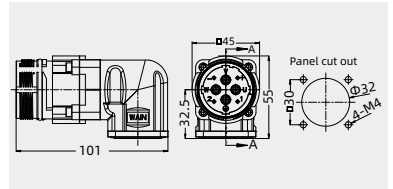
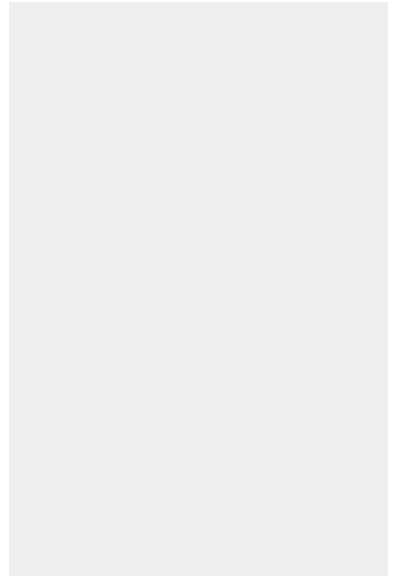

## Accessories

## Crimp contacts

signal



NO.	Male	Order No.
①	M40-AMC30G-1.0	101 032 210 0811
②	M40-AMC30G-1.5	101 032 210 0911
③	M40-AMC30G-2.5	101 032 210 1011
④	M40-AMC75G-4	101 024 210 1201
⑤	M40-AMC75G-6	101 024 210 1301
⑥	M40-AMC75G-10	101 024 210 1401

power



## Tools

Crimping tool



Wire gauge	Designation	Order No.
0.14-4mm <sup>2</sup>	TL28-2	198 001 001 0039
1.5-10mm <sup>2</sup>	TL28-3	198 001 001 0040

Contact removal tool



Application	Designation	Order No.
for crimp contacts 75A	M40-TL01	198 001 000 0027
for crimp contacts 30A	M40-TL02	198 001 000 0028

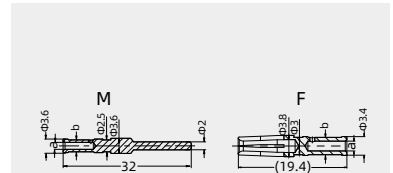

NO.	wire gauge	Stripping Length	a	b
①	1 mm <sup>2</sup>	7 mm	φ1.45	φ2.6
②	1.5 mm <sup>2</sup>	7 mm	φ1.75	φ3/φ3.1
③	2.5 mm <sup>2</sup>	7 mm	φ2.25	φ3.4

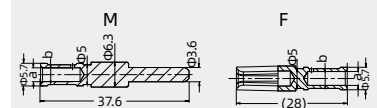

NO.	wire gauge	Stripping Length	a	b
④	4 mm <sup>2</sup>	10 mm	φ2.85	φ3.9
⑤	6 mm <sup>2</sup>	10 mm	φ3.5	φ5
⑥	10 mm <sup>2</sup>	10 mm	φ4.5	φ5.7

Notes: The tools for crimp terminal may influence the product quality and stability. Please select the tools recognized by our company.

## Accessories

## Protection covers IP67

## M40 Protection cover



Description	Designation	Order No.
Dustproof	M40-CV-F1	170 000 001 9502
	M40-CV-F2	170 000 001 9503

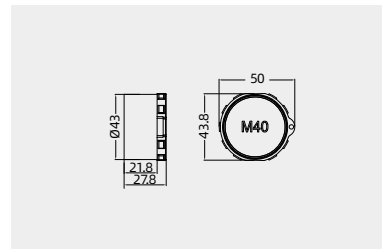

M40

## Circular Connector M40

- M40-MC04/4-BKP-SE Power connector

1: Open the upper cover horizontally

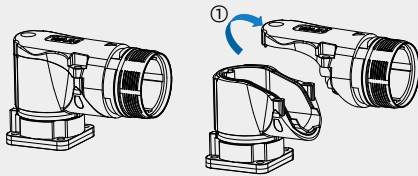

2: pin wiring

- The cable passes through the fixed base.
- Strip the wire insulation husk, and then weld pin to the wire.

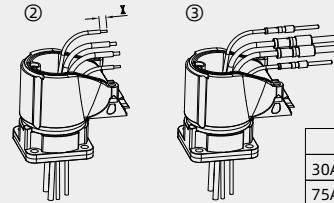

3: Insert the pins to the corresponding insert holes in order.

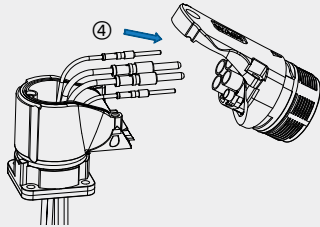

4: Lock the upper cover, and fasten the screws. The installation is completed.

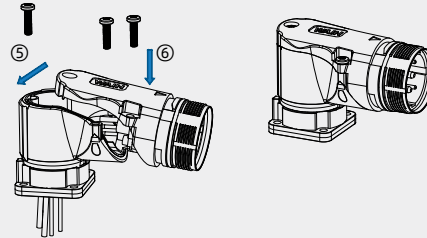



## Q38 Multi-pin Connectors For Vehicle



Q38

## Circular Connector Q38

250V 30/13A

## Technical characteristics

Specifications			
Specifications	DIN EN 60 664 DIN EN 61 984		
Electrical data		Mechanical properties	
Number of contacts	12+19	-Mechanical working life	≥ 500 次
Electrical properties		-Lock mode	Quick connect card slot
-Rated current	30A (power) 13A (signal)	Environmental performance	
-Rated voltage	250V	-Working temperature	-55°C ...+105°C
-Rated impulse voltage	2000V	-Degree of Protection	IP67
Material and finish		-Pollution degree	3
-Hoods/Housings	The copper alloy plating nickel / PA		
-contact	Gold-plated copper alloy		
-Insulating material	PA		
-Sealing element	FKM, silica gel		

## Male, Crimp terminal

Order crimp contacts separately



Contacts	Designation	Order No.
12+19	Q38-MC12/19-BK40-D29	174 031 310 3500

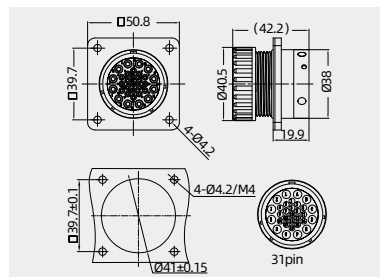

## Female, Crimp terminal

Order crimp contacts separately



Contacts	Designation	Order No.
12+19	Q38-FC12/19-T-D29	174 031 420 3500

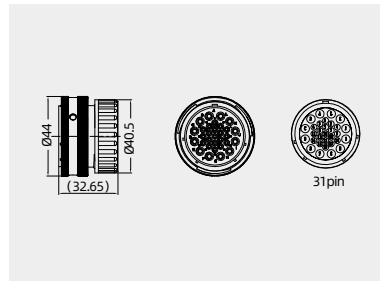

## Accessories

## Crimp contacts

signal



power



NO.	Male	Order No.	Female	Order No.
①	Q38-MC13G-1.5	2010413100901	Q38-FC13G-1.5	2010413200901
②	Q38-MC30G-2.5	2010323101001	Q38-FC30G-2.5	2010323201001

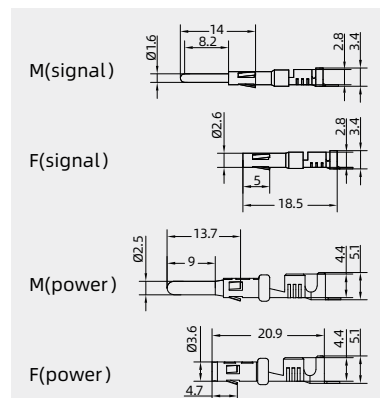

## Circular Connector Q38

250V 30/13A

## Technical characteristics

Specifications			
Specifications	DIN EN 60 664 DIN EN 61 984		
Electrical data		Mechanical properties	
Number of contacts	32 (28+4)	-Mechanical working life	≥ 500 次
Electrical properties		-Lock mode	Quick connect card slot
-Rated current	30A (power) 13A (signal)	Environmental performance	
-Rated voltage	250V	-Working temperature	-55°C ...+105°C
-Rated impulse voltage	2000V	-Degree of Protection	IP67
Material and finish		-Pollution degree	3
-Hoods/Housings	The copper alloy plating nickel / PA		
-contact	Gold-plated copper alloy		
-Insulating material	PA		
-Sealing element	FKM, silica gel		

Q38

## Male, Crimp terminal

Order crimp contacts separately

Contacts	Designation	Order No.
32(28+4)	Q38-MC04/28-BK40-D29	174 032 310 3500

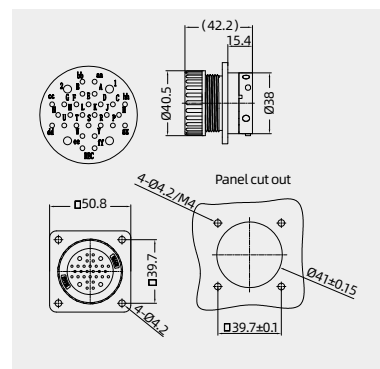

## Male, Crimp terminal

Order crimp contacts separately

Contacts	Designation	Order No.
32(28+4)	Q38-MC04/28-CCT/R-D29	174 032 310 3501

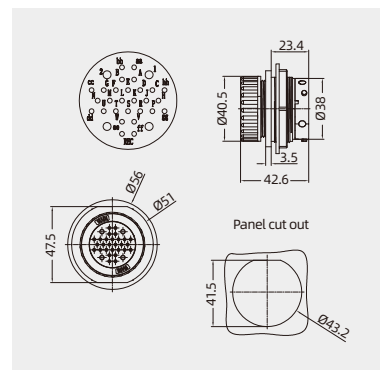

## Accessories

## Crimp contacts

signal

NO.	Male	Order No.	Female	Order No.
①	Q38-MC13G-1.5	2010413100901	Q38-FC13G-1.5	2010413200901
②	Q38-MC30G-2.5	2010323101001	Q38-FC30G-2.5	2010323201001

power

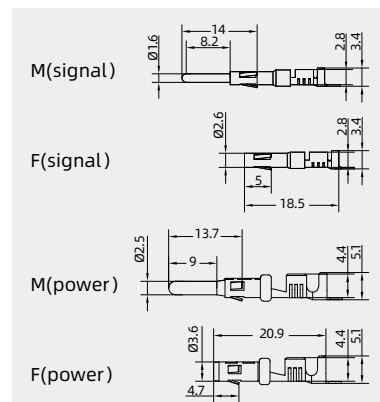



## Circular Connector Q38

250V 30/13A

## Technical characteristics

Specifications			
Specifications	DIN EN 60 664 DIN EN 61 984		
Electrical data		Mechanical properties	
Number of contacts	32 (28+4)	-Mechanical working life	$\geq 500$ 次
Electrical properties		-Lock mode	Quick connect card slot
-Rated current	30A (power) 13A (signal)	Environmental performance	
-Rated voltage	250V	-Working temperature	-55°C ...+105°C
-Rated impulse voltage	2000V	-Degree of Protection	IP67
Material and finish		-Pollution degree	3
-Hoods/Housings	The copper alloy plating nickel / PA		
-contact	Gold-plated copper alloy		
-Insulating material	PA		
-Sealing element	FKM, silica gel		

## Female, Crimp terminal

Order crimp contacts separately

Contacts	Designation	Order No.
32(28+4)	Q38-FC04/28-T-D29	174 032 320 3500

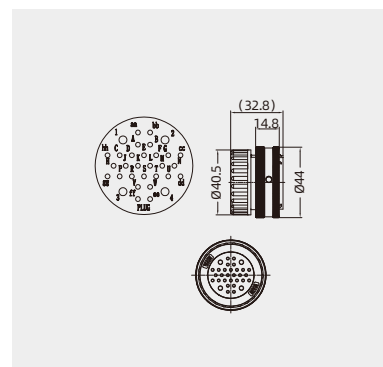
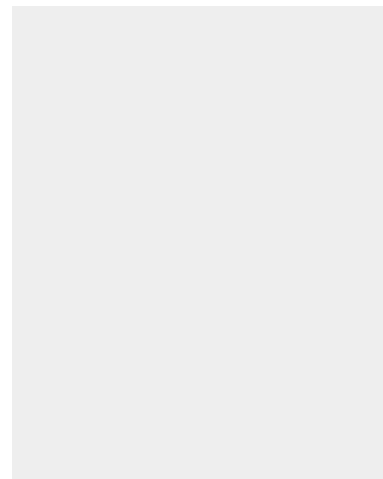

## Accessories

## Crimp contacts

signal

NO.	Male	Order No.	Female	Order No.
①	Q38-MC13G-1.5	2010413100901	Q38-FC13G-1.5	2010413200901
②	Q38-MC30G-2.5	2010323101001	Q38-FC30G-2.5	2010323201001

power

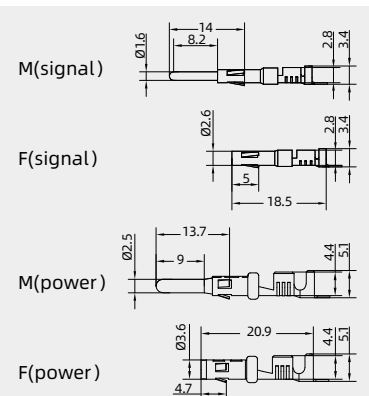

## Circular Connector Q38

250V 13A

## Technical characteristics

Specifications			
Specifications	DIN EN 60 664 DIN EN 61 984		
Electrical data		Mechanical properties	
Number of contacts	48	-Mechanical working life	$\geq 500$ 次
Electrical properties		-Lock mode	Quick connect card slot
-Rated current	13A (signal)	Environmental performance	
-Rated voltage	250V	-Working temperature	-55°C ...+105°C
-Rated impulse voltage	2000V	-Degree of Protection	IP67
Material and finish		-Pollution degree	3
-Hoods/Housings	The copper alloy plating nickel / PA		
-contact	Gold-plated copper alloy		
-Insulating material	PA		
-Sealing element	FKM, silica gel		

Q38

## Male, Crimp terminal

Order crimp contacts separately



Contacts	Designation	Order No.
48	Q38-MC48-BK40-D29	174 048 310 3501

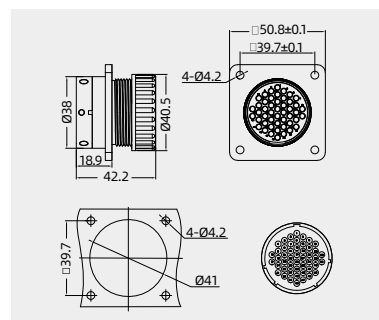

## Male, Crimp terminal

Order crimp contacts separately



Contacts	Designation	Order No.
48	Q38-MC48-CCT/R-D29	174 048 310 3500

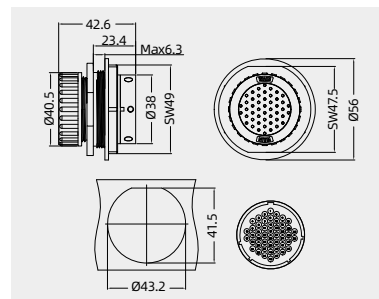

## Accessories

## Crimp contacts

signal



NO.	Male	Order No.	Female	Order No.
①	Q38-MC13G-1.5	2010413100901	Q38-FC13G-1.5	2010413200901

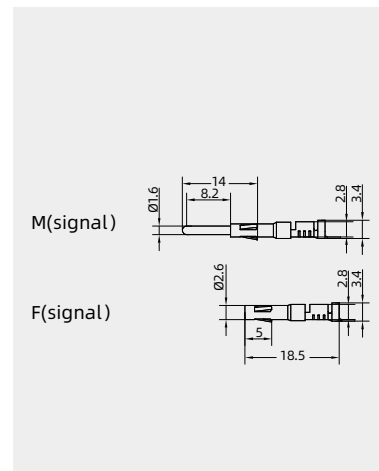

## Circular Connector Q38

250V 13A

## Technical characteristics

Specifications			
Specifications	DIN EN 60 664 DIN EN 61 984		
Electrical data		Mechanical properties	
Number of contacts	48	-Mechanical working life	≥ 500 次
Electrical properties		-Lock mode	Quick connect card slot
-Rated current	13A (signal)	Environmental performance	
-Rated voltage	250V	-Working temperature	-55°C ...+105°C
-Rated impulse voltage	2000V	-Degree of Protection	IP67
Material and finish		-Pollution degree	3
-Hoods/Housings	The copper alloy plating nickel / PA		
-contact	Gold-plated copper alloy		
-Insulating material	PA		
-Sealing element	FKM, silica gel		

## Female, Crimp terminal

Order crimp contacts separately

Contacts	Designation	Order No.
48	Q38-FC48-T-D29	174 048 420 3500

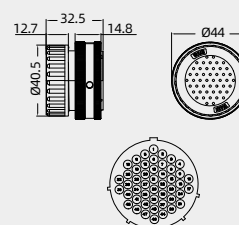

## Accessories

## Crimp contacts

signal

NO.	Male	Order No.	Female	Order No.
①	Q38-MC13G-1.5	2010413100901	Q38-FC13G-1.5	2010413200901

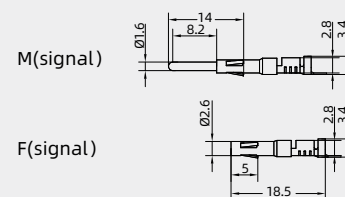

# Power connector(National grid standard)



## Power connector

250V 40A

## Technical characteristics

Specifications			
Specifications	DIN EN 60 664 DIN EN 61 984		
Approvals		Mechanical properties	
Electrical data		-Vibration	frequency 10~2000Hz, accelerated speed 1.47m/s <sup>2</sup> , instant break ≤ 1us
Number of contacts	4	-Shock	accelerated speed 490m/s <sup>2</sup> , instant break ≤ 1us
Electrical properties		-Mechanical working life	≥ 500
-Rated current	40A	-Lock mode	Thread locking
-Rated voltage	250V (AC)	-Cable and outlet diameter	10.5mm
-Rated impulse voltage	2kV (AC)	Environmental performance	
-Insulation resistance	≥ 2000MΩ (normal temperature)	-Relative humidity	90%~95% (40°C ± 2°C)
-Welding wire specifications	plugs 2.0mm <sup>2</sup> ~3.3mm <sup>2</sup> (Φ2.2mm) socket 2.0mm <sup>2</sup> ~4mm <sup>2</sup> (Φ2.7mm)	-Working temperature	-40°C~+105°C
-Contact resistance	≤ 0.75mΩ	-Salt mist test requirements	5% NaCl neutral steady salt mist 96 h
Material and finish		-Degree of Protection	IP65
-Hoods/Housings	The copper alloy plating nickel		
-contact	Gold-plated copper alloy		
-Insulating material	Thermosets		
-Sealing element	Rubber		

## Solder terminal



Insert	Designation	Order No.
Male	HY-Z2504-S01E0-GM	169 004 313 1001

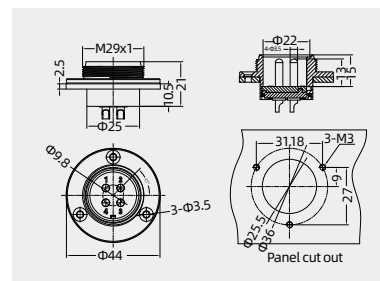

## Solder terminal



Insert	Designation	Order No.
Female	HY-T2504-S01E1-GF	169 004 423 1001

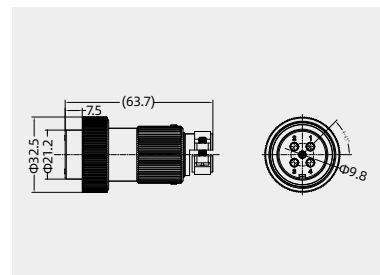

## Accessories

## Protection cover



Description	Designation	Order No.
for male	HY-Z25-CV	269 000 000 9001

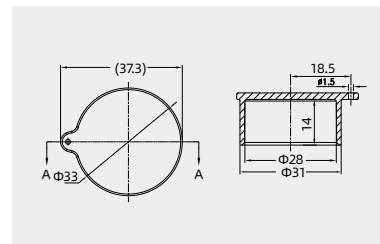

# Power connector

250V 20A

## Technical characteristics

Specifications			
Specifications	DIN EN 60 664 DIN EN 61 984		
Approvals			
Electrical data		Mechanical properties	
Number of contacts	5	-Vibration	frequency 10~2000Hz, accelerated speed 147m/s <sup>2</sup> , instant break ≤ 1us
Electrical properties		-Shock	accelerated speed 490m/s <sup>2</sup> , instant break ≤ 1us
-Rated current	20A	-Mechanical working life	≥ 500
-Rated voltage	250V (AC)	-Lock mode	Thread locking
-Rated impulse voltage	2.0kV(normal temperature) 1.0kV(muggy)	-Cable and outlet diameter	10.5mm
-Insulation resistance	≥ 2000MΩ(normal temperature) ≥ 50 MΩ(muggy)	Environmental performance	
-Contact resistance	≤ 2 mΩ	-Relative humidity	90%~95% (40°C ±2°C)
-Welding wire specifications	Diameter φ1.8mm	-Working temperature	-40°C—+105°C
Material and finish		-Salt mist test requirements	5% NaCl neutral steady salt mist 96 h
-Hoods/Housings	The copper alloy plating nickel	-Degree of Protection	IP65
-contact	Gold-plated copper alloy		
-Insulating material	Thermosets		

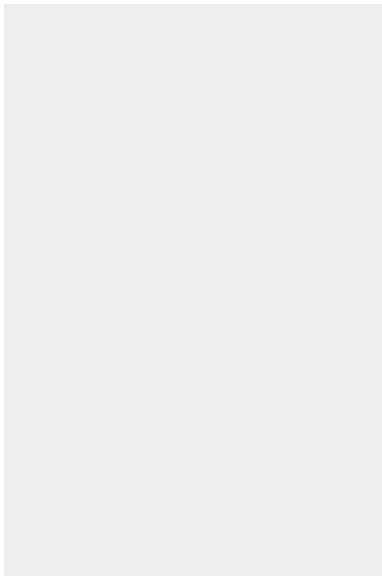

### Solder terminal



Insert	Designation	Order No.
Male	HY-Z2505-S01E0-GM	169 005 313 1001

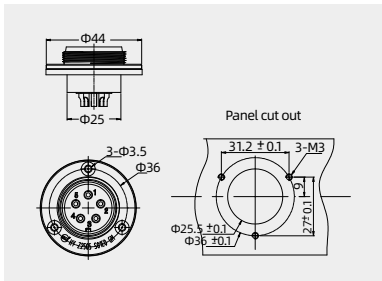

### Solder terminal



Insert	Designation	Order No.
Female	HY-T2505-S01E1-GF	169 005 423 1001

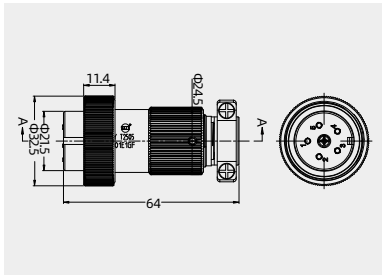

## Accessories

### Protection cover



Description	Designation	Order No.
for male	HY-Z25-CV	269 000 000 9001

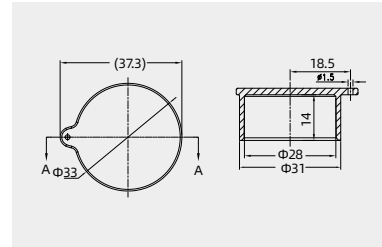

## Power connector

250V 25A

## Technical characteristics

Specifications	
Specifications	DIN EN 60 664 DIN EN 61 984
Approvals	
Electrical data	
Number of contacts	6
Electrical properties	
-Rated current	25A
-Rated voltage	250V (AC)
-Rated impulse voltage	2kV (AC)
-Insulation resistance	$\geq 2000\text{M}\Omega$ (normal temperature)
-Contact resistance	$\leq 1\text{m}\Omega$
Material and finish	
-Hoods/Housings	Copper alloy
-contact	Gold-plated copper alloy
-Insulating material	Thermosets
-Sealing element	Rubber
Mechanical properties	
-Vibration	frequency 10~2000Hz, accelerated speed 147m/s <sup>2</sup> , instant break $\leq 1\mu\text{s}$
-Shock	accelerated speed 490m/s <sup>2</sup> , instant break $\leq 1\mu\text{s}$
-Mechanical working life	$\geq 500$
-Lock mode	Thread locking
-Cable and outlet diameter	$\Phi 12.5\text{mm}$
Environmental performance	
-Relative humidity	90%~95% (40°C $\pm 2^\circ\text{C}$ )
-Working temperature	-40°C—+105°C
-Salt mist test requirements	5% NaCl neutral steady salt mist 96 h
-Degree of Protection	IP65

## Crimp terminal

Order crimp contacts separately



Insert	Designation	Order No.
Male	HY-T3006-S01E1-GMC	169 006 410 1001

## Crimp terminal

Order crimp contacts separately

Can match the Protection cover:HY-Z30-CV



Insert	Designation	Order No.
Female	HY-Z3006-S01E0-GFC	169 006 320 1001

## Accessories

## Crimp contacts 25A

Contact resistance  $\leq 1\text{m}\Omega$   
gold plated

NO.	Male	Order No.	Female	Order No.
①	CYGM25-0.5	101 021 210 0401	CYGF25-0.5	101 021 220 0401
②	CYGM25-0.75	101 021 210 0601	CYGF25-0.75	101 021 220 0601
③	CYGM25-1.0	101 021 210 0801	CYGF25-1.0	101 021 220 0801
④	CYGM25-1.5	101 021 210 0901	CYGF25-1.5	101 021 220 0901
⑤	CYGM25-2.5	101 021 210 1001	CYGF25-2.5	101 021 220 1001
⑥	CYGM25-3.0	101 021 210 1101	CYGF25-3.0	101 021 220 1101

## Tools

## Crimping tool



## Contact removal tool



Wire gauge	Designation	Order No.
0.14-4mm <sup>2</sup>	TL02G	198 002 000 0011

Application	Designation	Order No.
for crimp contacts 25A	HY-TL01	198 001 000 0020

Notes: The tools for crimp terminal may influence the product quality and stability. Please select the tools recognized by our company.

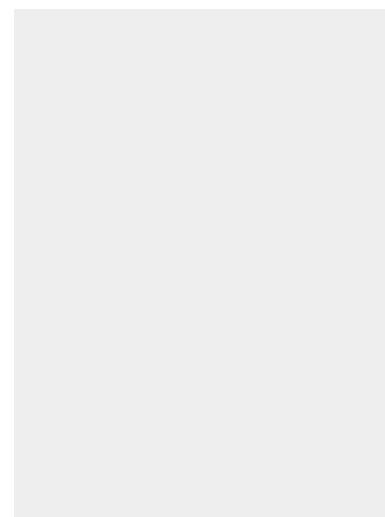

power

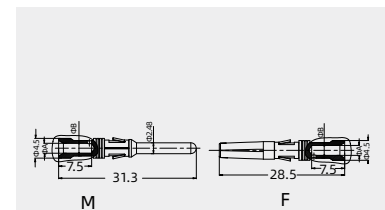
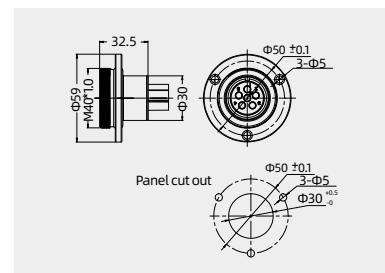
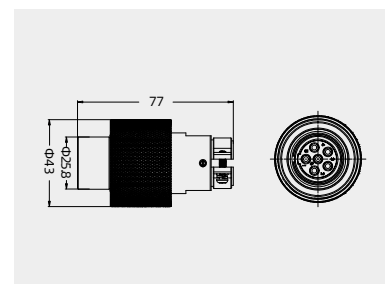

NO.	Identification	$\Phi A/\text{mm}$	$\Phi B/\text{mm}$	Wire gauge
①	no groove	1.15	2.60	0.5 mm <sup>2</sup> AWG20
②	1 groove	1.30	2.60	0.75 mm <sup>2</sup> AWG18
③	1 groove	1.45	2.60	1.0mm <sup>2</sup> AWG18
④	2 groove	1.75	3.00	1.5 mm <sup>2</sup> AWG16
⑤	3 groove	2.25	3.50	2.5 mm <sup>2</sup> AWG14
⑥	2 groove	2.55	3.75	3.0mm <sup>2</sup> AWG12

## Power connector

250V 40A

## Technical characteristics

Specifications	
Specifications	DIN EN 60 664 DIN EN 61 984
Approvals	
Electrical data	
Number of contacts	6(The open circuit)
Electrical properties	
-Rated current	40A
-Rated voltage	250V (AC)
-Rated impulse voltage	2kV
-Insulation resistance	$\geq 2000\text{M}\Omega$ (normal temperature)
-Contact resistance	$\leq 1\text{m}\Omega$
Material and finish	
-Hoods/Housings	The copper alloy plating nickel
-contact	Gold-plated copper alloy
-Insulating material	PA
-Sealing element	Silicone rubber, FKM
Mechanical properties	
-Vibration	frequency10-2000Hz,accelerated speed147m/s <sup>2</sup> , instant break $\leq 1\mu\text{s}$
-Shock	accelerated speed 490m/s <sup>2</sup> , instant break $\leq 1\mu\text{s}$
-Mechanical working life	$\geq 500$
-Lock mode	Bayonet locking
-Cable and outlet diameter	$\Phi 13\text{mm}$
Environmental performance	
-Relative humidity	90%~95% (40°C $\pm 2^\circ\text{C}$ )
-Working temperature	-40°C—+105°C
-Salt mist test requirements	5% NaCl neutral steady salt mist 96 h
-Degree of Protection	IP65

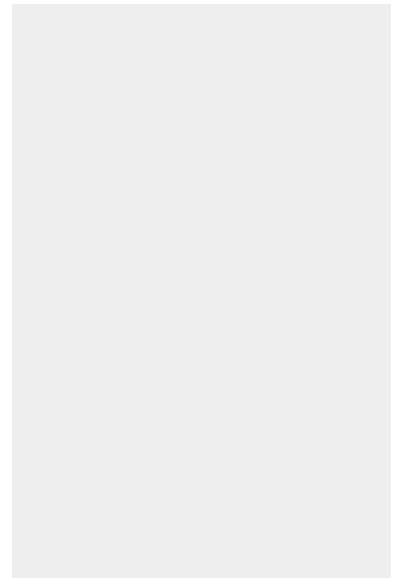

## Solder terminal



Insert	Designation	Order No.
Male	HY-PZ3006-S01E0-GM	169 006 313 1001

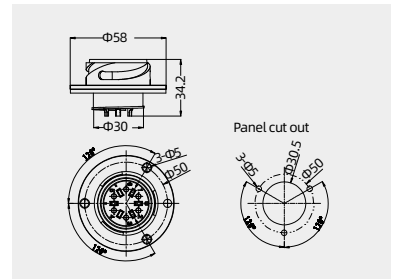

## Solder terminal



Insert	Designation	Order No.
Female	HY-PT3006-S01E1-GF	169 006 423 1001

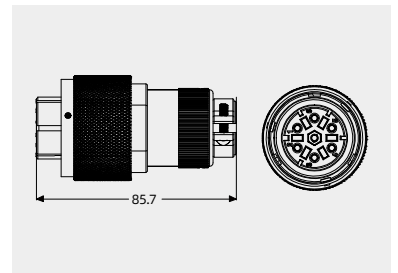

## Accessories

## Protection cover



Description	Designation	Order No.
for male	HY-Z30-CV	269 000 000 9002

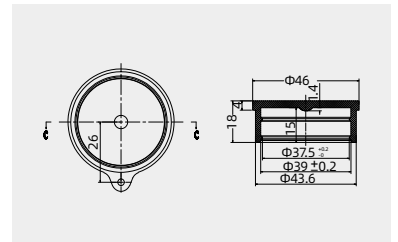



## Power connector

250V 13/20A

## Technical characteristics

Specifications			
Specifications	DIN EN 60 664 DIN EN 61 984		
Approvals			
Electrical data		Mechanical properties	
Number of contacts	10(4+6)	-Vibration	frequency10~2000Hz,accelerated speed147m/s2, instant break $\leq 1\mu s$
Electrical properties		-Shock	accelerated speed 490m/s2, instant break $\leq 1\mu s$
-Rated current	6X $\phi 1.59$ : 13A 4X $\phi 2$ : 20A	-Mechanical working life	$\geq 500$
-Rated voltage	250V (AC)	-Lock mode	Thread locking
-Rated impulse voltage	2kV	-Cable and outlet diameter	$\phi 13\text{mm}$
-Insulation resistance	$\geq 2000\text{M}\Omega$ (normal temperature)	Environmental performance	
-Contact resistance	$\phi 1.59$ : $\leq 3\text{m}\Omega$ $\phi 2$ : $\leq 2\text{m}\Omega$	-Relative humidity	90%~95% (40°C $\pm 2^\circ\text{C}$ )
-Welding wire specifications	Diameter $\phi 1.8\text{mm}$	-Working temperature	-40°C—+105°C
Material and finish		-Salt mist test requirements	5% NaCl neutral steady salt mist 96 h
-Hoods/Housings	The copper alloy plating nickel	-Degree of Protection	IP65
-contact	Gold-plated copper alloy		
-Insulating material	Thermosets		

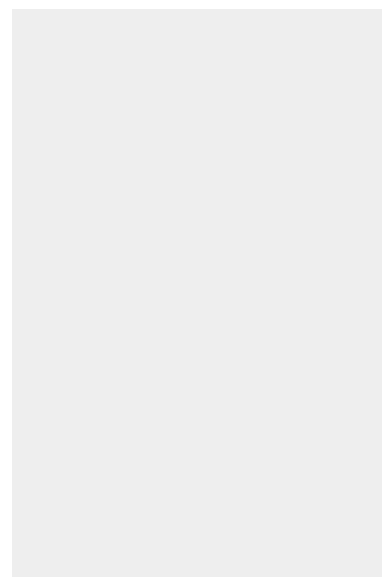

## Solder terminal



Insert	Designation	Order No.
Male	HY-Z3010-S01E0-GM	169 010 313 1001

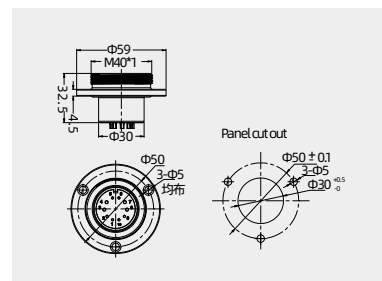

## Solder terminal



Insert	Designation	Order No.
Female	HY-T3010-S01E1-GF	169 010 423 1001

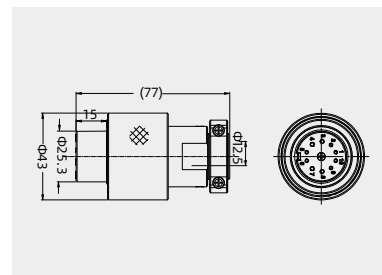

## Accessories

## Protection cover



Description	Designation	Order No.
for male	HY-Z30-CV	269 000 000 9002

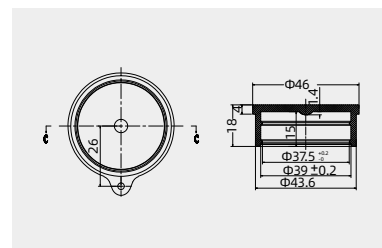



# Ethernet-Power connector

## Technical characteristics

Specifications	
Specifications	DIN EN 60 664 DIN EN 61 984
Approvals	
Electrical data	
Number of contacts	Two sides RJ-45/3pins
Electrical properties	
-Rated current	-/1A
-Rated voltage	-/220V(AC)
-Rated impulse voltage	500V(AC)/1500V(AC)
-Insulation resistance	≥ 500MΩ(normal temperature)
-Contact resistance	≤ 20mΩ/ ≤ 7.5mΩ
-Wire splice	Power line: 1 mm <sup>2</sup>
specification	Reticle: 24 AWG
Material and finish	
-Hoods/Housings	The copper alloy plating chromium
-contact	Gold-plated copper alloy
-Insulating material	Thermosets
Mechanical properties	
-Vibration	1frequency10~2000Hz,accelerated speed147m/s <sup>2</sup> , instant break ≤ 1us
-Shock	accelerated speed 490m/s <sup>2</sup> , instant break ≤ 1us
-Mechanical working life	≥ 500
-Lock mode	Bayonet locking
-Cable and outlet diameter	Φ11.5 mm
Environmental performance	
-Relative humidity	90%-95% (40°C ±2°C)
-Working temperature	-40°C—+105°C
-Salt mist test requirements	5% NaCl neutral steady salt mist 96 h
-Degree of Protection	IP65

### Solder terminal

Insert	Designation	Order No.
Male	HY-ET2511-S02E1-GM	169 011 410 1001

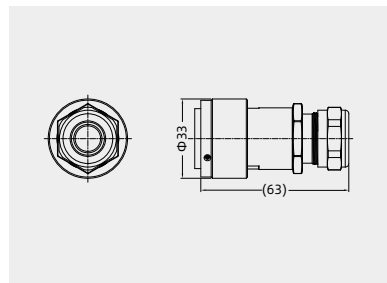
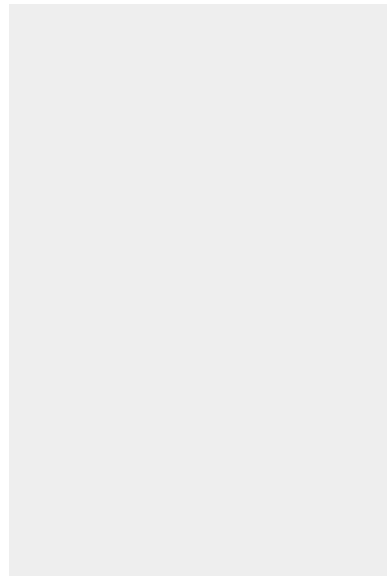
### Solder terminal

Insert	Designation	Order No.
Female	HY-EZ2511-S02E0-GF	169 011 323 1001

## Accessories

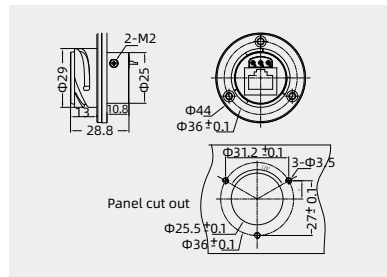
### Protection cover

Description	Designation	Order No.
for male	HY-Z25-CV	269 000 000 9001

## Heavy-current cable butting connector

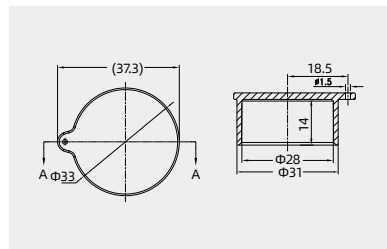

### Advantages:

- The male plug is provided with a quick-connect nut anti-rotation device to play the role of nut anti-rotation.
- Increase the assembly clearance of pin to prevent damage of connector caused by thermal expansion and cold contraction.
- Add a variety of coding to the insertion of male and female plugs to avoid wrong insertion.
- Color codes distinguish three - phase cables.
- Double crown spring is adopted to increase the contact area of male and female pins.
- Protection against electric shock.
- Add the wire size mark to the pin.

# Heavy-current cable butting connector

1000V 800A

## Technical characteristics

Specifications		Mechanical data	
Specifications	DIN EN 60 664 DIN EN 61 984	Housing material	PA
Approvals		Contact material	Copper alloy
Number of contacts		surface	Hard-gold plated
Electrical parameters:	1	Terminal	Crimp version
Rated current		Gasket and O ring	FPM
Rated voltage	800A	Ambient temperature	-40°C ...+125°C
Test voltage Urms (AC)	1000V	Locking type	Quick lock
Wire gauge	12kV	Mechanical working life	> 100
Surge voltage category	240mm <sup>2</sup>	Degree of protection	IP65
Pollution degree	III	Cable diameter	32-37mm
Pollution degree	3		

### Male,Crimp terminal



Insert	Designation	Order No.
Male	HW-MC01-T-D37	182 000 410 3001

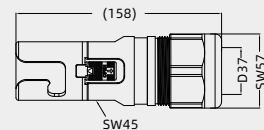

### Male,Crimp contacts



Wire gauge(mm <sup>2</sup> )	Designation	Order No.
240	HW-MC800S-240	101 035 110 2401

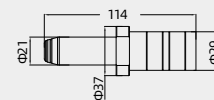

HW

## Heavy-current cable butting connector

1000V 800A

## Technical characteristics

Specifications		Mechanical data	
Specifications	DIN EN 60 664 DIN EN 61 984	Housing material	PA
Approvals		Contact material	Copper alloy
Electrical data		surface	Hard-gold plated
Number of contacts	1	Terminal	Crimp version
Electrical parameters:		Gasket and O ring	FPM
Rated current	800A	Ambient temperature	-40°C ...+125°C
Rated voltage	1000V	Locking type	Quick lock
Test voltage Urms (AC)	12kV	Mechanical working life	> 100
Wire gauge	240mm <sup>2</sup>	Degree of protection	IP65
Surge voltage category	III	Cable diameter	32-37mm
Pollution degree	3		

HW

## Female,Crimp terminal



Insert	Designation	Order No.
Female	HW-FC01-T-D37	182 000 420 3001

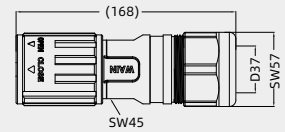

## Female,Crimp contacts



Wire gauge(mm <sup>2</sup> )	Designation	Order No.
240	HW-FC800S-240	101 035 120 2401

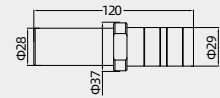

# Assembly instructions

## Installation steps



### Step 1



### Step 2: Crimping

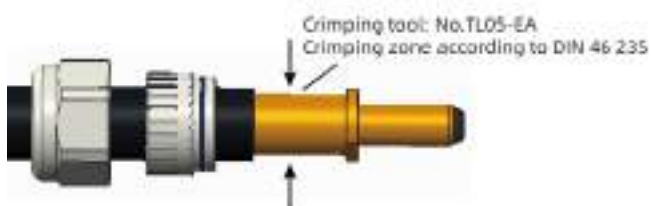

### Step 3: fastening



### Step 4: matching the slot

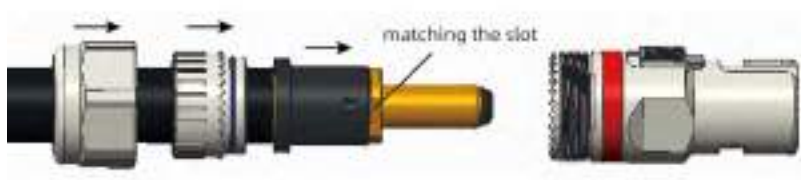

### Step 5: installation complete

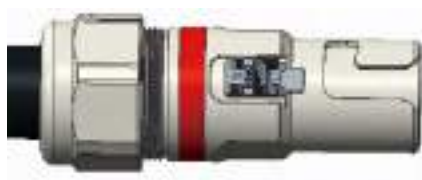

## MI mini connector



MI



## MI mini connector

400/30V 6/1A

## Technical characteristics

Number of contacts	6+6(5+PE)
Rated current (40°C)	6A(power), 1A(signal)
Rated voltage	400V(power), 30V(signal)
Rated impulse voltage	4000V(power), 500V(signal)
Pollution degree	3
Contact resistance	≤ 5 mΩ
Termination	crimp terminal
Wire gauge	MAX0.75mm <sup>2</sup>
Degree of protection	IP67(Acc. to EN60529 for coupled connector)
Limiting temperature	-40°C ...+130°C
Flammability acc. to UL 94	V0
Contact plating	Au

## Angeled double zone double cable shielded connector

Male, Shielded, Crimp terminal

Order crimp contacts separately



Contacts	Cable outlet	Designation	Order No.
6+6(5+PE)	7.5mm	MI-MC06/6-BK-OD2.7	173 012 310 4001

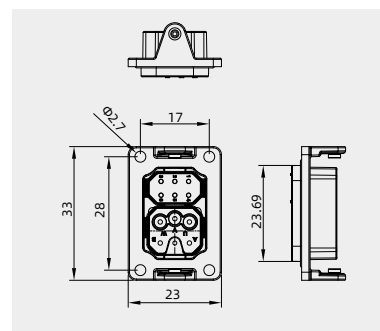

Female, Shielded, Crimp terminal

Order crimp contacts separately



Contacts	Cable outlet	Designation	Order No.
6+6(5+PE)	7.5mm	MI-FC06/6-SE-2D7.5-SH	173 012 520 2001

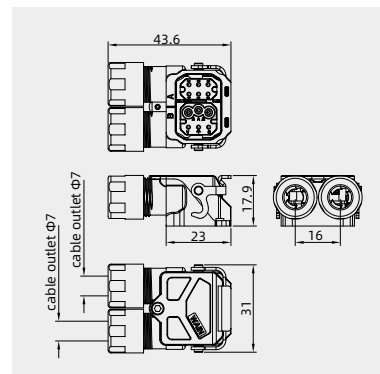

## Crimp contacts

Crimp contacts

Contact resistance ≤ 3mΩ  
gold plated

Wire gauge(mm <sup>2</sup> )	Male	Order No.
0.09-0.25	MI-MC6G2-0.25	101 040 210 0101
0.13-0.52	MI-MC6G-0.38	101 040 210 3801
0.52-0.75	MI-MC6G-0.75	101 040 210 0601
Wire gauge(mm <sup>2</sup> )	Female	Order No.
0.09-0.25	MI-FC6G2-0.25	101 040 220 0101
0.13-0.52	MI-FC6G-0.38	101 040 220 3801
0.52-0.75	MI-FC6G-0.75	101 040 220 0601

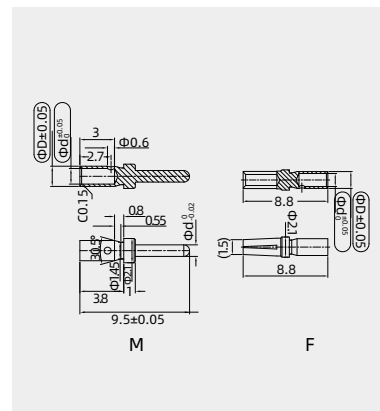

Tools

Crimping tool



Wire gauge	Designation	Order No.
0.09-0.82mm <sup>2</sup>	TL03	198 001 001 0002

Notes: The tools for crimp terminal may influence the product quality and stability. Please select the tools recognized by our company.

## HCC SERIES

Single row connector



## HCC single row inserts



## Technical characteristics

Specifications	
Specifications	DIN EN 60 664 DIN EN 61 984
Approvals	ERC
Inserts	
Rated current	30A
Rated voltage	500V
Rated impulse voltage	6kV
Pollution degree	3
Limiting temperatures	-40°C ...+125°C
Flammability	V0
Mechanical working life(mating cycles)Mechanical working life(mating cycles)	≥ 500
Contacts	
Number of contacts	10
Terminal	screw terminal
Wire gauge	0.32~4mm <sup>2</sup>
Material	copper alloy
Surface	silver plated

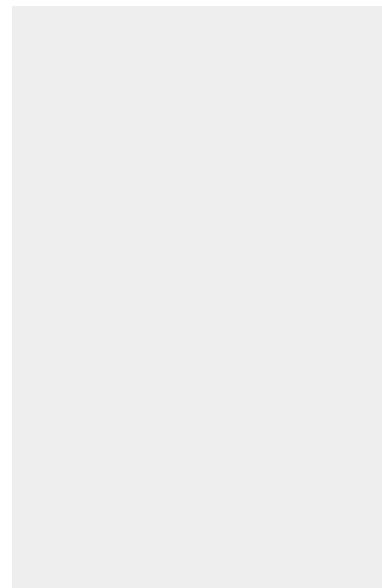

HCC

## Inserts

Inserts	Designation	Order No.
Male	HCC-010-M	133 010 011 0001
Female	HCC-010-F	133 010 021 0001

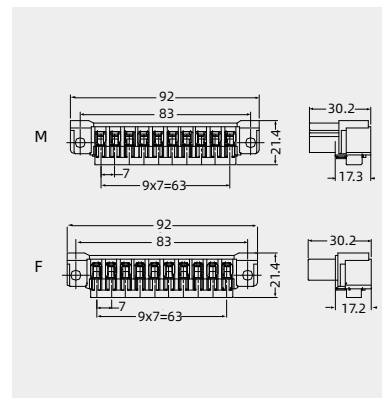

# HV SERIES

Single row connector



## HV single row inserts



## Technical characteristics

Specifications/Approvals	
Specifications	DIN EN 60 664 DIN EN 61 984
Approvals	FR
Inserts	
Number of contacts	8 +PE
Rated current	20A
Rated voltage	400V
Rated impulse voltage	6kV
Pollution degree	3
Insulation resistance	$\geq 10^{10}\Omega$
Flammability (UL94)	V0
Mechanical working life(mating cycles)	$\geq 500$
Material	PA
Limiting temperature	-40°C ...+100°C
Contacts	
Material	copper alloy
Surface	tin plating
Contact resistance	$\leq 1m\Omega$
Terminal	
-Screw terminal	
-Wire gauge	0.2—4.0mm <sup>2</sup>
-Tightening torque	0.5~0.6Nm
-Stripping length	7.0mm
Hoods/Housings	
Material	Zine-alloy
Surface	nickel plating
Locking element	Screw locking
Sealing element	NBR
Limiting temperatures	-40°C ~+125°C
Degree of protection	IP67

## Current carrying capacity

The current carrying is limited by maximum temperature of materials for inserts and contacts including terminals  
Control and test procedures according to DIN EN 60512-5

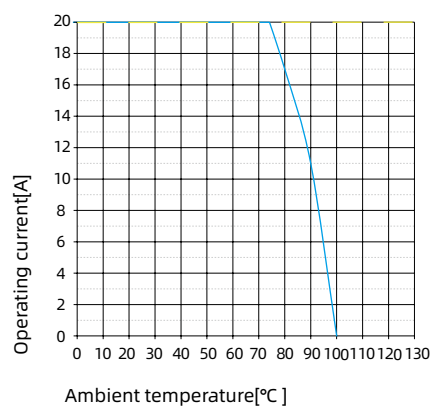

## HV single row inserts

400V 20A 8+

### Inserts



Inserts	Designation	Order No.
Male	HV-S02-M	232 002 011 0002
Female	HV-S02-F	232 002 021 0002

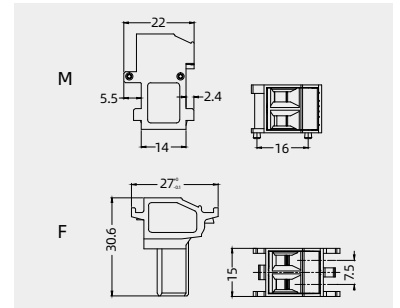

Description	Designation	Order No.
Panel ground	HV-A-PEA	132 000 000 0001

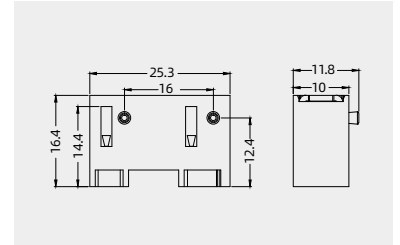

External member 1  
with female inserts and frame



Description	Designation	Order No.
hoods/housings frame external member	HV-HF3/4M-PEA-S2222	132 008 021 0001

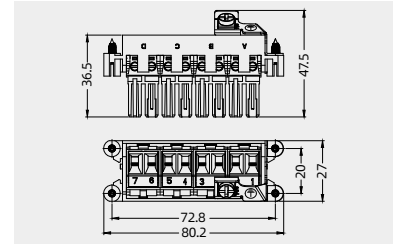

HV

External member 2  
with male inserts and frame



Description	Designation	Order No.
Panel frame external member	HV-AF3/4M-PEA-S2222	132 008 011 0001

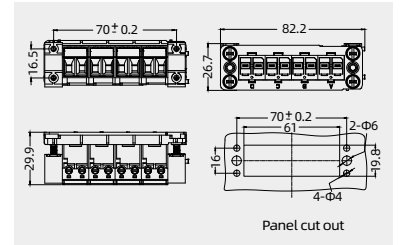

Plug piece



Description	Designation	Order No.
Preventing interpolation	CODE-V	198 002 005 0012

# HV single row inserts

400V 20A 8+ 

## Inserts

Hoods/Housings, nickel plating



screw	Designation	Order No.
M25	EMC.HV-PM-H3/C-M25	132 604 420 1003

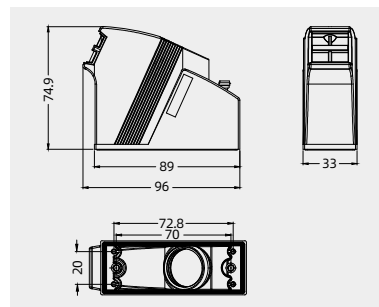

## Frame



Description	Designation	Order No.
with 4 module hoods/housings frame	HV-HF3/4M-PEA	132 004 000 0002

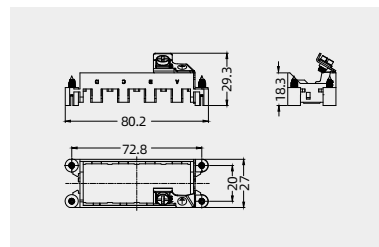

# The State Grid Anti-Open Connector

32 pin DTU anti-open circuit connector



32 pin



## The State Grid Anti-Open Connector



### Technical characteristics

<b>Specifications/Approvals</b>	
Specifications	DIN EN 60 664 DIN EN 61 984
<b>Approvals</b>	
<b>Inserts</b>	
Number of contacts	24+8(anti-open circuit)+1(grounding)
Rated current	10A
Rated voltage	250V
Rated impulse voltage	4kV
Pollution degree	3
Insulation resistance	$\geq 10^{10}\Omega$
Flammability (UL94)	V0
Mechanical working life(mating cycles)	$\geq 500$
Material	PC
Limiting temperature	-40°C ...+125°C
<b>Contacts</b>	
Material	copper alloy
Surface	silver plated
Contact resistance	$\leq 5m\Omega$
Terminal	crimp terminal / Screw terminal
-crimp terminal	0.14-2.5mm <sup>2</sup> (26-14AWG)
-Screw terminal	0.75-2.5mm <sup>2</sup> (18-14AWG)
-solde terminal	Φ1.6/Φ2.4(grounding) Welding pin
<b>Hoods/Housings</b>	
Material	PC
Sealing element	NBR
Flammability acc. to UL 94	V0
Limiting temperatures	-40°C ...+125°C
Degree of protection	IP65

32 pin

## 32 pin DTU anti-open circuit connector

250V 10A 24+8 (anti-open circuit) +1

### Inserts

#### Hoods/Housings



screw	Designation	Order No.
M32	HDC.P-DTU-SE-4S-M32	119 000 520 1001

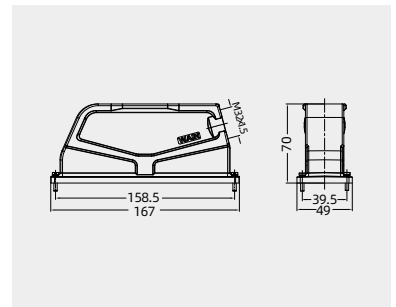

#### Inserts



Inserts	Designation	Order No.
Female	HDC-DTU-008/10/14-FC	125 032 020 0001

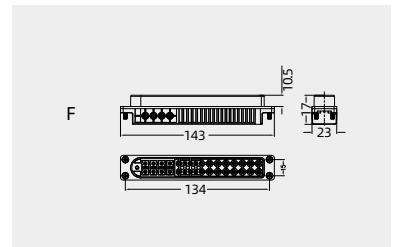

### Crimp contacts

#### Crimp contacts 10A

Contact resistance  $\leq 3m\Omega$   
silver plated



gold plated



Female (silver plated)	Order No.	Female (gold plated)	Order No.
CDSF-0.25	101 017 120 0101	CDGF-0.25	101 017 220 0101
CDSF-0.37	101 017 120 0301	CDGF-0.37	101 017 220 0301
CDSF-0.50	101 017 120 0401	CDGF-0.50	101 017 220 0401
CDSF-0.75	101 017 120 0601	CDGF-0.75	101 017 220 0601
CDSF-1.0	101 017 120 0801	CDGF-1.0	101 017 220 0801
CDSF-1.5	101 017 120 0901	CDGF-1.5	101 017 220 0901
CDSF-2.5	101 017 120 1001	CDGF-2.5	101 017 220 1001

More crimp contacts 10A  
see P13-02,P13-03.

#### Tools

##### Crimping tool



##### Contact removal tool



Wire gauge	Designation	Order No.
0.14-4mm <sup>2</sup>	TL02G	198 001 001 0011

Application	Designation	Order No.
for crimp contacts 10A	TL00	198 001 000 0001

More tools detail please find the page32-03~32-06.

F

Wire gauge	$\Phi$	Stripping length
0.14-0.37 mm <sup>2</sup> AWG 26-22	0.9	8 mm
0.5 mm <sup>2</sup> AWG 20	1.1	8 mm
0.75 mm <sup>2</sup> AWG 18	1.3	8 mm
1 mm <sup>2</sup> AWG 18	1.45	8 mm
1.5 mm <sup>2</sup> AWG 16	1.75	8 mm
2.5 mm <sup>2</sup> AWG 14	2.25	6 mm

When the wire gauge is less than 0.75mm<sup>2</sup>, it's better to use the auxiliary pin assembly tool TL15.

Notes: The tools for crimp terminal may influence the product quality and stability. Please select the tools recognized by our company.

32 pin DTU anti-open circuit connector

250V 10A 24+8 (anti-open circuit) +1 

### Inserts

Inserts

Inserts	Designation	Order No.
Male	HDC-DTU-008/10/14-MC-4H	125 032 010 0001

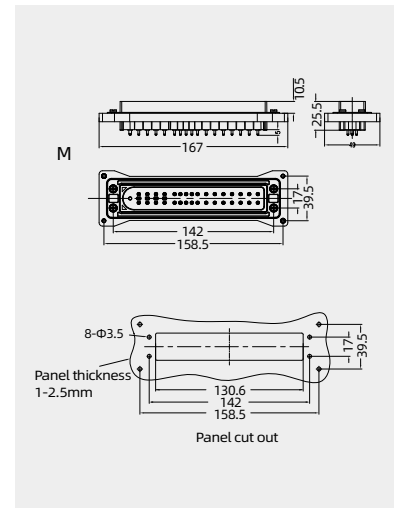

32 pin

## The State Grid Anti-Open Connector

56 pin TTU anti-open circuit connector



56 pin

## The State Grid Anti-Open Connector



### Technical characteristics

<b>Specifications/Approvals</b>	
Specifications	DIN EN 60 664 DIN EN 61 984
<b>Approvals</b>	
<b>Inserts</b>	
Number of contacts	8+8 (anti-open circuit) +40
Rated current	10A
Rated voltage	250V
Rated impulse voltage	4kV
Pollution degree	3
Insulation resistance	$\geq 10^{10}\Omega$
Flammability acc. to UL 94	V0
Mechanical working life(mating cycles)	$\geq 500$
Material	PC
Limiting temperatures	-40°C ...+125°C
<b>Contacts</b>	
Material	copper alloy
Surface	silver plated/gold plated
Contact resistance	$\leq 3m\Omega$
<b>Anti open circuit contact:</b>	
-Terminal	Screw terminal
-Wire gauge	0.75-2.5mm <sup>2</sup> (18-14AWG)
<b>voltage wire contact:</b>	
-Terminal	Crimp terminal
-Wire gauge	0.14-2.5mm <sup>2</sup> (26-14AWG)
<b>signal contact:</b>	
-Terminal	Crimp terminal
-Wire gauge	0.09-0.52mm <sup>2</sup> (28-20AWG)
<b>Hoods/Housings</b>	
Material	PC
Sealing element	NBR
Flammability acc. to UL 94	V0
Limiting temperatures	-40°C ...+125°C
Degree of protection	IP65

56 pin

# 56 pin TTU anti-open circuit connector

250V 10A 8+8 (anti-open circuit) +40

## Inserts

### Hoods, side entry



screw	Designation	Order No.
M32	HDC.P-TEH-4B-M32	119 000 430 5001

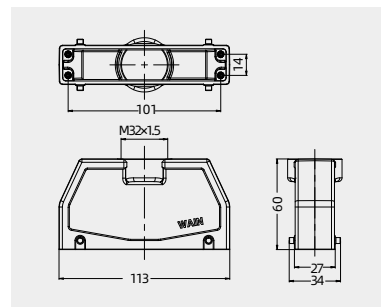

### Housings, bulkhead mounting



Inserts	Designation	Order No.
Female	HDC.P-BKH-2L	119 000 349 5001

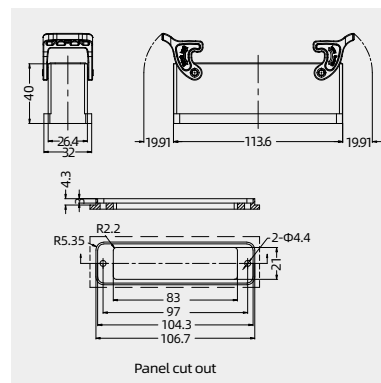

# 56 pin TTU anti-open circuit connector

250V 10A 8+8 (anti-open circuit) +40

## Inserts

Screw terminal/Crimp terminal  
Order crimp contacts separately

Inserts	Designation	Order No.
Male	HDC-008/8/40-MC	125 056 010 0001
Female	HDC-008/8/40-FC	125 056 020 0001

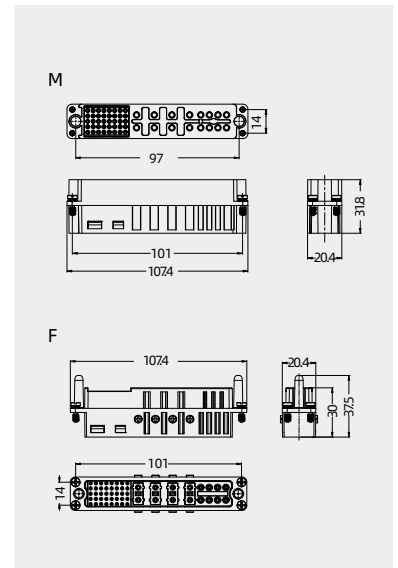

## Crimp contacts

Crimp contacts 5A

Contact resistance  $\leq 3m\Omega$   
silver plated



gold plated



Male	Order No.	Female	Order No.
CSSM-0.25	101 014 110 0101	CSSF-0.25	101 014 120 0101
CSSM-0.33	101 014 110 0201	CSSF-0.33	101 014 120 0201
CSSM-0.52	101 014 110 0501	CSSF-0.52	101 014 120 0501
CSGM-0.25	101 014 210 0101	CSGF-0.25	101 014 220 0101
CSGM-0.33	101 014 210 0201	CSGF-0.33	101 014 220 0201
CSGM-0.52	101 014 210 0501	CSGF-0.52	101 014 220 0501

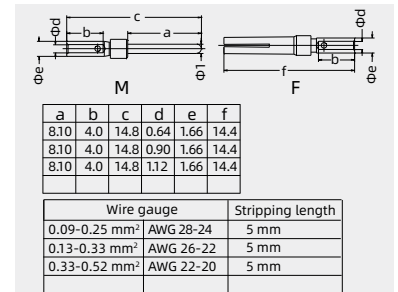

56 pin

Stamped contacts 5A

Contact resistance  $\leq 10m\Omega$   
silver plated



gold plated



Male	Order No.	Female	Order No.
CSSM-0.82P	101 014 110 0750	CSSF-0.82P	101 014 120 0750
CSGM-0.82P	101 014 210 0750	CSGF-0.82P	101 014 220 0750

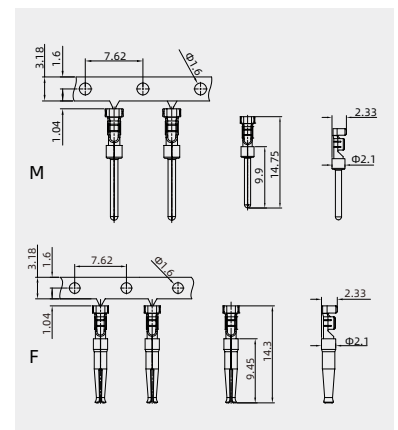

Notes: The tools for crimp terminal may influence the product quality and stability. Please select the tools recognized by our company.

## 56 pin TTU anti-open circuit connector

250V 10A 8+8 (anti-open circuit) +40

### Crimp contacts

#### Crimp contacts 10A



Contact resistance  $\leq 3m\Omega$   
silver plated

Male	Order No.	Female	Order No.
CDSM-0.25	101 017 110 0101	CDSF-0.25	101 017 120 0101
CDSM-0.37	101 017 110 0301	CDSF-0.37	101 017 120 0301
CDSM-0.50	101 017 110 0401	CDSF-0.50	101 017 120 0401
CDSM-0.75	101 017 110 0601	CDSF-0.75	101 017 120 0601
CDSM-1.0	101 017 110 0801	CDSF-1.0	101 017 120 0801
CDSM-1.5	101 017 110 0901	CDSF-1.5	101 017 120 0901
CDSM-2.5	101 017 110 1001	CDSF-2.5	101 017 120 1001
CDGM-0.25	101 017 210 0101	CDGF-0.25	101 017 220 0101
CDGM-0.37	101 017 210 0301	CDGF-0.37	101 017 220 0301
CDGM-0.50	101 017 210 0401	CDGF-0.50	101 017 220 0401
CDGM-0.75	101 017 210 0601	CDGF-0.75	101 017 220 0601
CDGM-1.0	101 017 210 0801	CDGF-1.0	101 017 220 0801
CDGM-1.5	101 017 210 0901	CDGF-1.5	101 017 220 0901
CDGM-2.5	101 017 210 1001	CDGF-2.5	101 017 220 1001



gold plated

More crimp contacts 10A  
see P13-02, P13-03.

#### Tools

Crimping tool	Wire gauge	Designation	Order No.
	0.09-0.82mm <sup>2</sup>	TL03	198 001 001 0002
Contact removal tool	Application	Designation	Order No.
	for 5A crimp contact	TL08	198 001 000 0006

#### Tools

Crimping tool	Wire gauge	Designation	Order No.
	0.14-4mm <sup>2</sup>	TL02G	198 001 001 0011
Contact removal tool	Application	Designation	Order No.
	for 10A crimp contact	TL00	198 001 000 0001

Notes: The tools for crimp terminal may influence the product quality and stability. Please select the tools recognized by our company.

More tools detail please find the page 32-03~32-06.

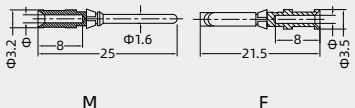

Identification	$\Phi$	Stripping length	
0.09-0.25 mm <sup>2</sup>	AWG 28-24	0.65	5 mm
0.14-0.37 mm <sup>2</sup>	AWG 26-22	0.9	8 mm
0.5 mm <sup>2</sup>	AWG 20	1.1	8 mm
0.75 mm <sup>2</sup>	AWG 18	1.3	8 mm
1 mm <sup>2</sup>	AWG 18	1.45	8 mm
1.5 mm <sup>2</sup>	AWG 16	1.75	8 mm
2.5 mm <sup>2</sup>	AWG 14	2.25	6 mm

When the wire gauge is less than 0.75mm<sup>2</sup>, it's better to use the auxiliary pin assembly tool TL15.



# The State Grid Anti-Open Connector

## 6 pins Anti-Open Connector



### Technical characteristics

<b>Specifications/Approvals</b>	
Specifications	DIN EN 60 664 DIN EN 61 984
<b>Approvals</b>	
<b>Inserts</b>	
Number of contacts	6+PE
Three Groups of Preventive Opening	1-2, 3-4, 5-6
Rated current	40A
Rated voltage	500V
Rated impulse voltage	6kV
Pollution degree	3
Insulation resistance	$\geq 10^{10}\Omega$
Material	PC
Colour	RAL 7032(light grey)
Temperature range	-40°C ...+125°C
Flammability acc. to UL 94	V0
Mechanical working life(mating cycles)	$\geq 500$
<b>Contacts</b>	
Terminal	screw terminal
Material	copper alloy
Surface	silver plated/gold plated
Contact resistance	$\leq 5m\Omega$
<b>Wire</b>	
-gauge	1.5-6mm <sup>2</sup>
-AWG	(16-10)
Tightening torque	0.8N.m
Stripping length	10mm

# The State Grid Anti-Open Connector

500V 40A 6+PE

## Inserts

Hoods/Housings: size **WV6B/HV6B**

Screw terminal

Inserts	Designation	Order No.
Male	HSC-006-M	127 006 011 0511
Female	HSC-006-F	127 006 021 0512

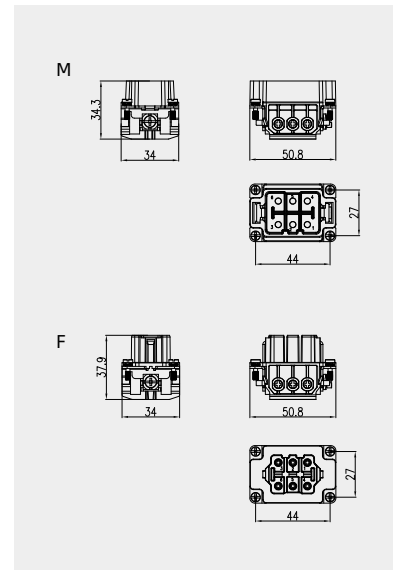

Interlock protection level: IP65



Hoods, top entry



Thread	Designation	Order No.
M25	HDC.P-TE-4B-M25	119 000 430 1001

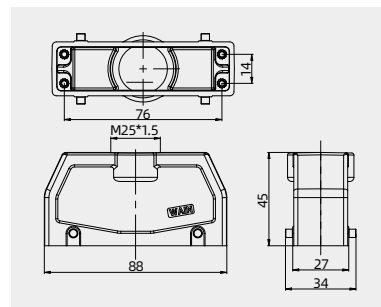

Housings, bulkhead mounting



Description	Designation	Order No.
-	HDC.P-BK-2L	119 000 340 1001

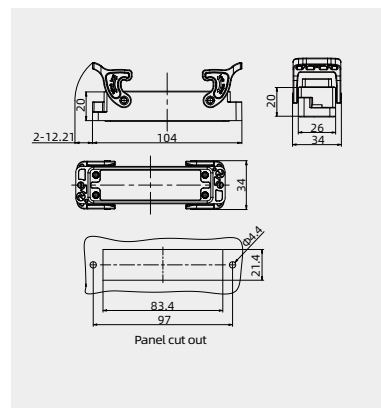

# 16 pin TTU anti-open circuit connector

250V 10A 8+8 (The open circuit)



## Inserts

### Crimp terminal

Order crimp contacts separately



Inserts	Designation	Order No.
Male	HDC-008/8-MC	125 016 010 0001
Female	HDC-008/8-FC	125 016 020 0001

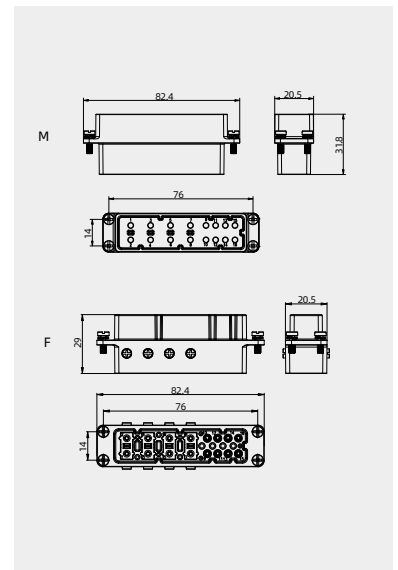

## Crimp contacts

### Crimp contacts 10A

Contact resistance  $\leq 3m\Omega$   
silver plated



gold plated



More crimp contacts 10A  
see P13-02,P13-03.

Male	Order No.	Female	Order No.
CDSM-0.25	101 017 110 0101	CDSF-0.25	101 017 120 0101
CDSM-0.37	101 017 110 0301	CDSF-0.37	101 017 120 0301
CDSM-0.50	101 017 110 0401	CDSF-0.50	101 017 120 0401
CDSM-0.75	101 017 110 0601	CDSF-0.75	101 017 120 0601
CDSM-1.0	101 017 110 0801	CDSF-1.0	101 017 120 0801
CDSM-1.5	101 017 110 0901	CDSF-1.5	101 017 120 0901
CDSM-2.5	101 017 110 1001	CDSF-2.5	101 017 120 1001
CDGM-0.25	101 017 210 0101	CDGF-0.25	101 017 220 0101
CDGM-0.37	101 017 210 0301	CDGF-0.37	101 017 220 0301
CDGM-0.50	101 017 210 0401	CDGF-0.50	101 017 220 0401
CDGM-0.75	101 017 210 0601	CDGF-0.75	101 017 220 0601
CDGM-1.0	101 017 210 0801	CDGF-1.0	101 017 220 0801
CDGM-1.5	101 017 210 0901	CDGF-1.5	101 017 220 0901
CDGM-2.5	101 017 210 1001	CDGF-2.5	101 017 220 1001

Identification	Φ	Stripping length
0.09-0.25 mm <sup>2</sup>	AWG 28-24	0.65 5 mm
0.14-0.37 mm <sup>2</sup>	AWG 26-22	0.9 8 mm
0.5 mm <sup>2</sup>	AWG 20	1.1 8 mm
0.75 mm <sup>2</sup>	AWG 18	1.3 8 mm
1 mm <sup>2</sup>	AWG 16	1.45 8 mm
1.5 mm <sup>2</sup>	AWG 16	1.75 8 mm
2.5 mm <sup>2</sup>	AWG 14	2.25 6 mm

When the wire gauge is less than 0.75mm<sup>2</sup>, it's better to use the auxiliary pin assembly tool TL15.

### Tools

#### Crimping tool



#### Contact removal tool



Wire gauge	Designation	Order No.
0.14-4mm <sup>2</sup>	TL02G	198 001 001 0011

Application	Designation	Order No.
for crimp contacts 10A	TL00	198 001 000 0001

More tools detail please find the page 32-03~32-06.

Notes: The tools for crimp terminal may influence the product quality and stability. Please select the tools recognized by our company.



## D-Sub-044 SERIES

### D-Sub-044





## Technical characteristics

<b>Specifications/Approvals</b>	
Specifications	DIN EN 60 664 DIN EN 61 984
<b>Approvals</b>	
<b>Inserts</b>	
Number of contacts	44
Rated current	3A
Rated voltage	40V
Rated impulse voltage	0.5kV
Pollution degree	3
Insulation resistance	$\geq 10^{10}\Omega$
Flammability (UL94)	V0
Mechanical working life(mating cycles)	$\geq 500$
Material	PBT+copper alloy
Limiting temperature	-40°C ...+105°C
<b>Contacts</b>	
Material	copper alloy
Surface	Nickel plated floating gold
Contact resistance	$\leq 3m\Omega$
Rated current	3A
Wire gauge	0.09-0.25mm <sup>2</sup> (28-24 AWG)
Mechanical working life(mating cycles)	$\geq 500$
<b>Hoods/Housings</b>	
Material	Zinc die-cast
Surface	nickel plating
<b>Locking element</b>	
Locking element	1 lever
Material	Stainless steel
<b>Sealing element</b>	
Sealing element	NBR
Flammability acc. to UL 94	V0
Limiting temperatures	-40°C ~+125°C
Degree of protection	IP65

D-Sub-044

Inserts

Inserts



Inserts	Designation	Order No.
Male	DB-A044MC	998 002 099 0007
Female	DB-A044FC	998 002 099 0008

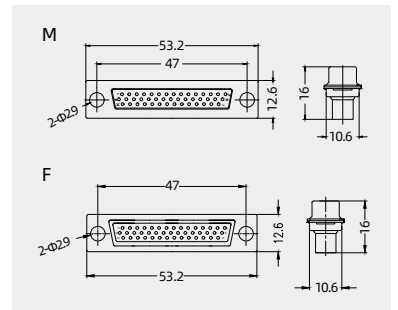

Contacts



Description	Designation	Order No.
Male	CSNM/DB-0.25P	998 002 099 0009
Female	CSNF/DB-0.25P	998 002 099 0010

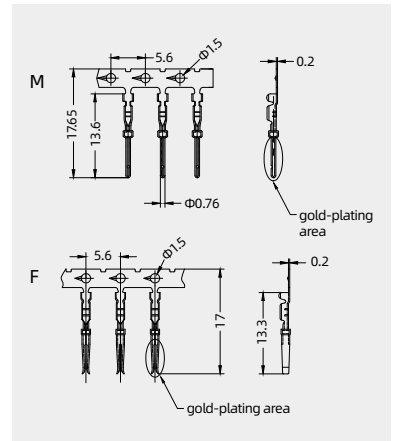

Note: pin roll material 15000pcs / roll



D-Sub-044

Hoods/Housings

Hoods/Housings, nickel plating



screw	Designation	Order No.
OM20	EMC.DS-044-SE-2B-OM20	112 300 510 1001

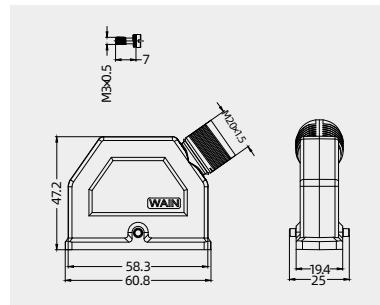

Bulkhead mounted housings



screw	Designation	Order No.
---	EMC.DS-044-BK-1L	112 300 320 1001

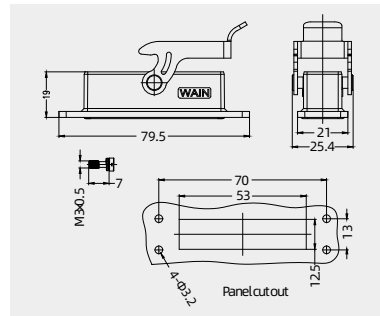

Protection covers, plastic(IP54)



Description for housings	Designation	Order No.
---	DS-044-CV/C	137 500 000 9001

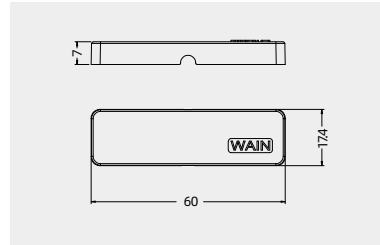

Cable gland



Description	Designation	Order No.
---	EMC.WNAMC-M20(D6-12)	102 118 015 1001

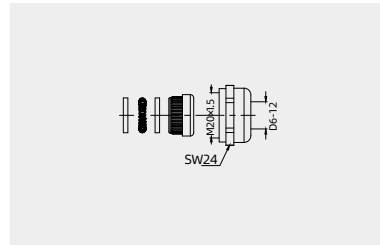

# Charging socket



# Charging socket



## Technical characteristics

<b>Specifications/Approvals</b>	
Specifications	DIN EN 60 664 DIN EN 61 984 CHAdEMO/IEC 62196-3
<b>Approvals</b>	
<b>Inserts</b>	
Number of contacts	8/2
<b>Rated current</b>	
-Power area	150A
-Signal area	2A
<b>Rated voltage</b>	
-Power area	500V
-Signal area	12V
<b>Rated impulse voltage</b>	
-Power area	6kV
-Signal area	2kV
Pollution degree	3
Insulation resistance	$\geq 10^{10}\Omega$
Flammability (UL94)	V0
Mechanical working life(mating cycles)	$\geq 10000$
Material	polyamide
Limiting temperature	-40°C ...+60°C
<b>Contacts</b>	
Material	copper alloy
Surface	silver plated
<b>Crimp terminal</b>	
-Power area	$\leq 1m\Omega$
-Signal area	$\leq 3m\Omega$
<b>Wire gauge</b>	
-Power area	40mm <sup>2</sup> (1 AWG)
-Signal area	0.75mm <sup>2</sup> (18 AWG)

## Charging socket

12V/500V 2A/150A 8/2

### Inserts



Other cable lengths can be customized.

screw	Designation	Order No.
	CHADM-S	103 010 220 0001
	CHADM-S-S1.0 <sup>1)</sup>	103 010 220 1001

1)Products with wire harness (1 meter length).

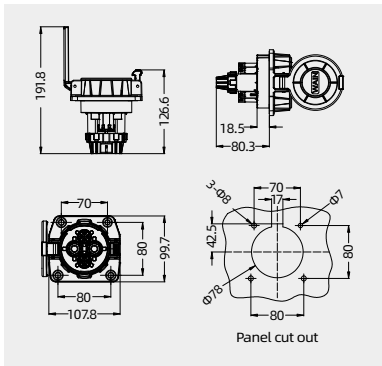

Inserts	Designation	Order No.
	CWSFH-0.75	101 012 120 0401
	CHWSFH-40G	101 036 120 3501

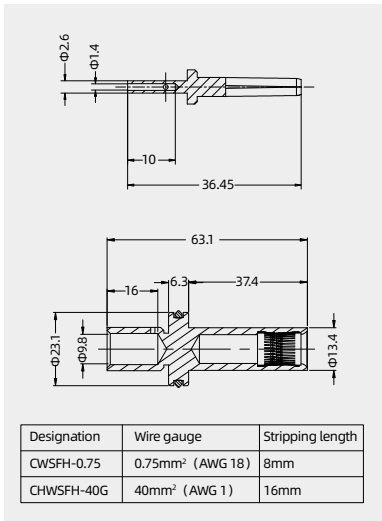

## TL-DZ Contact retention test tool

### TL-DZ Contact retention test tool

#### Contact retention test tool

Includes 1 handle +3 standard contact tester



Description	Designation	Order No.
Detect whether the turning contacts be assembled in place.	TL-DZ	198 001 003 0022

#### 16A female contact tester (optional)



Description	Designation	Order No.
Detect whether the turning contacts be assembled in place.	TL-DZ-FT/16A	298 001 003 0015

## Instruction Manual for Contact Retention Test Tool (TL-DZ)

TL-DZ is a tool used to detect the contact retention force. It solves the problem that the detection result is not intuitive by using the function of LED indicator. Compact structure, easy operation, chrome plated surface, beautiful appearance, service life  $\geq 100,000$  times, a variety of contact tester can be freely replaced, compatible with a variety of contact detection, and the detection force value can be customized by customers.

Function: Check whether the contacts be assembled in place.

Principle: The ejection force is controlled by the spring compression inside the handle, force range is 20-30N. If the indicator light is on and contacts do not exit, it indicates that the contacts have been assembled in place. If the contacts exit, it indicates that it has not been assembled in place.

Components: handle (1pc) +standard contact tester (3pcs) +optional contact tester (1pc) (tighten the contact tester on the handle during using)

The indicator

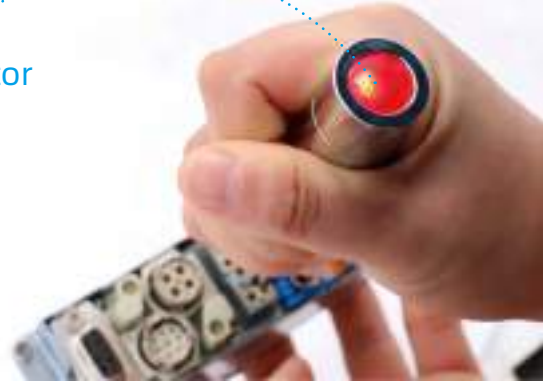

### Usage and Precautions:

1. According to the testing requirements, select the corresponding contact tester.
2. Hold the test tool by hand (Avoid obscuring the top red lampshade), align contact tester with the head of the contact, and push it forward to see that the indicator light is on (when the indicator light is on, do not force the contact tester again), and ensure that the test tool is perpendicular to the contacts;
3. Please check whether the contacts is bent or deformed after the contact tester detection. If the contact tester is not in the vertical state, the contact may be bent or deformed;
4. As the contact tester for 5A female contacts is thin, it is easy to break during operation. If it breaks, be sure to remove the broken tip from the pin hole; If the test tool is not used, please remove the tips and keep it well to avoid breakage;
5. The test tool shall regularly detect if the spring compression force in 20-30N, if the LED light works normally, if the battery power is insufficient, etc. (Note: if any above point is not satisfied, it shall be submitted for inspection);
6. The battery can be replaced independently when the battery power is insufficient. When replacing, unscrew the back cover of handle, pay attention to the installation direction of the positive and negative poles of the battery. (battery P/N: CR 1220; voltage 3V);
7. Do not use other unverified test tools to avoid damage to the contacts and connectors due to improper operations.

## Metallic outlet boxes

### Technical characteristics

可根据要求定制开孔方案

Specifications	
Specifications	DIN EN 60 664 DIN EN 61 984
Approvals	
Metallic outlet boxes	
Material	aluminium die-cast
Surface	powder-coated
Colour	RAL 7037 (grey)
Temperature range	-40°C ... +125°C
Degree of protection	IP65
Hoods/Housings sealing	NBR

#### Metallic outlet boxes



Description	Designation	Order No.
	MTB-120x120x80	139 500 000 9001

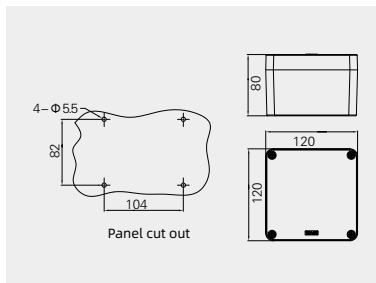

#### Metallic outlet boxes



Description	Designation	Order No.
	MTB-150x120x80	139 500 000 9002

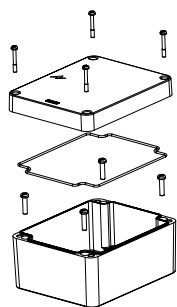
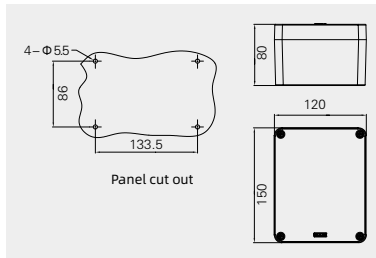

Lightning sign  
Red (RAL3003)

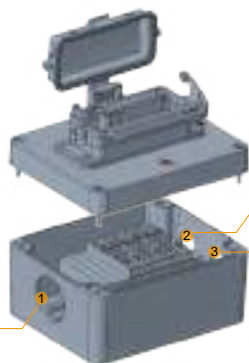
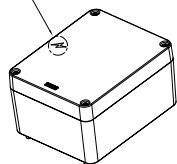

Hole opening①

Hole opening②

Hole opening③

Designation  
MTB-120x120x80  
MTB-150x120x80

Note: Hole opening can be customized according to requirements.

# I/O connector

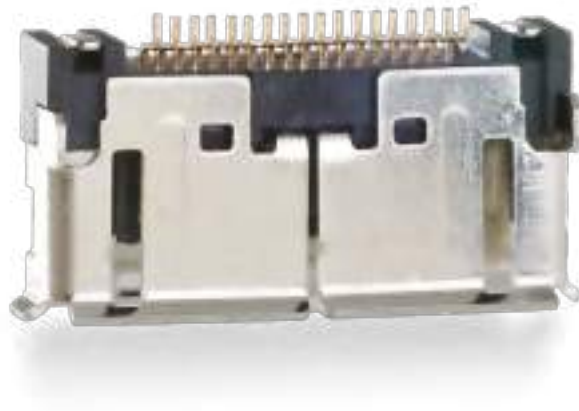



## I/O connector

100V 0.5A

## Inserts

## Technical characteristics

Specifications	DIN EN 60 664 DIN EN 61 984
Approvals	
Inserts	
Number of contacts	25
Electrical data acc. to EN 61 984	
- Rated current	0.5A
- Rated voltage	100V AC
- Rated impulse voltage	350V
Insulation resistance	$\geq 10^9 \Omega$
Material	LCP, Copper alloy, stainless steel
Limiting temperatures	-30°C ... +80°C
Salt spray requirements	48H
Flammability acc. to UL 94	V0
Mechanical working life	
- mating cycles	$\geq 10000$
Insertion and Extraction Force	29.4N max
Locking force	49N max

## I/O connector

Description	Designation	Order No.
-	WS-MR-18	141 010 180 0001

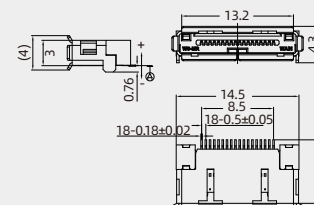

# WP connector



## WP connector

## Technical characteristics

Specifications	
	ISO/IEC 24 702 ISO/IEC 11 801 ISO/IEC 61 935-2
Cat.6a RJ45 female seat	Cat.6A RJ45 Patch cables
Transmission performance	Cable type EIA/TIA 568 B,8 poles Material cables PUR (RAL5021) Cable Length 0.8m
Transmission rate	10/100/1000Mbit/10Gbit/s
Shielding	fully shielded,360° shielding contact
Cable material	S/FTP,PUR, blue
Limiting temperatures	-25°C ...+70°C
Material(Hoods/Housings)	polyamine(RAL9005)
-fixed	-40°C ...+80°C
Degree of protection	IP20
Mechanical working life	
- mating cycle	≥ 750

## For wiring cables



Description	Designation	Order No.
--	WP-RJ45-JACK	135 001 112 0001

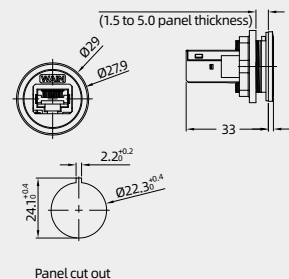

## Including cables



Description	Designation	Order No.
--	WP-RJ45-JACK/M08-T-0.8-Cat.6a	135 001 332 0001

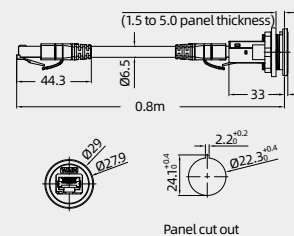

## Protection covers



Please refer to page 10-50.1 for matching cable

Degree of protection	Designation	Order No.
IP65	WP-JACK-SCV	135 001 000 0001

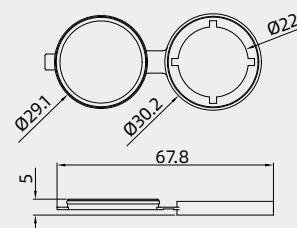

## Wiring Harness

Wiring harness customization



## Overview of wiring harness

Wiring harness which is composed of insulating sheath, terminal blocks, wires and insulating banding materials is a connecting part linking all electrical appliances within the same circuit.

WAIN customized wiring harness: Process and assemble the shells, cores, pins, cable glands, wire rods and other related parts of our company to manufacture customized wiring harness meeting the clients' requirements.

### I、 Classification of wiring harness

According to the quantity of connectors linking with the wiring harness, customized wiring harness can be classified into three categories, namely, single-ended wiring harness, double-ended wiring harness and multi-ended wiring harness.

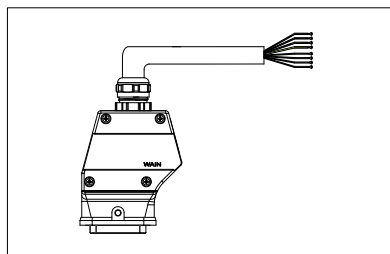

【drawing-1】

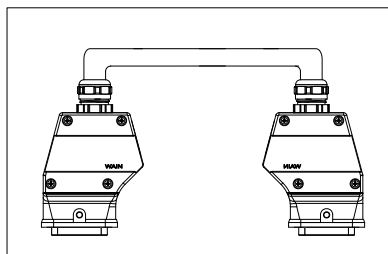

【drawing-2】

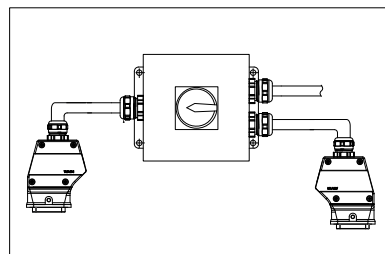

【drawing-3】

Single-ended wiring harness: One end of the wiring harness is equipped with connector of our Company, while the tail end can be crimped with terminals, equipped with cable marker or handled by the clients on their own.

【drawing-1】

Double-ended wiring harness: Both ends of the wiring harness are equipped with connectors of our Company.

【drawing-2】

Multi-ended wiring harness: Divide the wiring harness into multiple ends via junction box or add wire outlets at the shell, and equip the wiring harness with more than two connectors. 【drawing-3】

### II. Wire rods of wiring harness

According to the different operating environment, wire rods of wiring harness can be divided into the following types in accordance with the requirements of clients.:

1、 Standard electric wire: Applicable to clients who have no special requirements on the wire rods of wiring harness;

2、 Electric installation cable: Applicable to dry or humid indoor environment, especially for various kinds of electrical installation in industrial environment. Such cable with a cross section of 0.5mm<sup>2</sup> or above can be used as control and connecting flexible wire, which is especially applicable to machine tool manufacturing, complete equipment installation, power station, heating installation and air conditioner installation. (It can be equipped with signal shielding functions according to clients' requirements.)

3、 Fixed installation cable for lift shaft: Applicable to the installation and fixed laying in lift shaft; however, it can not be used as traveling cable of lift.

4、 Control cable: Applicable to control, signal, protection and measuring circuits with DC or AC 50-60 Hz and with rated voltage of 600/1000V and below. It is usually used in electrical control system and power distribution unit. (It can be equipped with signal shielding functions according to clients' requirements.)

5、 Oil-resistant cable: With oil-resistant feature, it is applicable to dry or humid indoor environment, installation with occasional moving but without slow release of strong stress or forced guiding. It also can be used in industrial environment with occasional bending and moving, such as machine tool, wood-working machine and grinding machine. (It can be equipped with signal shielding functions according to clients' requirements.)

6、 Standard power wire: inapplicable to power supply and illuminating system. In general, it can be categorized into rubber power wire and PVC power wire. According to the different using conditions, the power wire must conform to relevant national certification standards. (The power wire shall conform to China Compulsory Certification in China, VDE certification and CE certification in Europe and UL certification in USA, etc.)

7、 Towline cable: With the features of high flexibility and anti-bending ability, the cable is applicable to the installation with frequent bending but without slow release of strong stress or free continuous reciprocating movement which is forcedly guided.

In particular, it can be used in industrial environment with frequent bending, such as wood-working machine, machine tool, logistics transport system, crane, etc. (It can be equipped with signal shielding functions according to clients' requirements.)

Traveling control cable of lift: Applicable to traveling control of lift and long-distance hanging.

## Ordering process for wiring harness products



Free selection of wiring harness length  
The situation of using products of other suppliers:

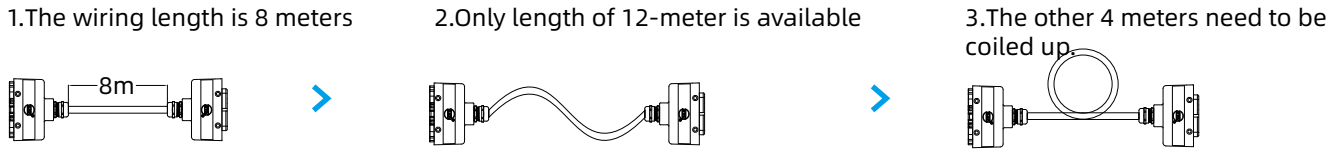

The situation of using WIAN products:

As WAIN products are manufactured according to the clients' requirements, the length can be designated with the unit as 0.1m.

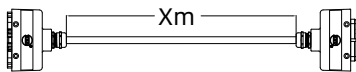

## Guide on model selection of wiring harness

### Five simple steps for model selection

	Type of inserts	Number of contacts	Type	Diagrammatic drawing	Type of cable	Designated unit
1. Select insert	GCHA(HE, HVE, HEE, HD, HK, HM, HQ, HC) Crimp terminal HA, HE... ...Series GLHA(HE, HVE, HSB, HK, HEAV, HM, HQ, HC) Screw terminal HA, HE... ...Series GTHA(HE, HVES, HM) HA, HE... ...Series	2 3 46 ... Select the number of contacts as required. See P00-03	M (male)		CCC	0.2-50m Designated unit 0.1m
2. Select number of contacts			F (female)		CE	
3. Select specification of insert			MM (male-male)		UL	
4. Appearance of wiring harness			FF (female-female)		VD	
5. Select length			MF (male-female)		According to the cable designated by clients!	
	YCHR23 Crimp terminal HR23 Series YLHR23(M8, M12) Screw terminal HR23, M8, M12 Series YHR23(M8, M12) Spring terminal HR23, M8, M12 Series	2 3 46 ... Select the number of contacts as required. See P00-03	M (male)		CCC	0.2-50m Designated unit 0.1m
			F (female)		CE	
			MM (male-male)		UL	
			FF (female-female)		VD	
			MF (male-female)		According to the cable designated by clients!	

## Quality assurance

### Control on welding process

#### 1, Temperature management

The welding temperature shall be maintained at 350°C and records shall be kept.



2, The welding operation shall be conducted by professional staff.

People conducting welding operation must pass examination before engaging in such work, and onsite examination shall be carried out.

3, Judgment criterion for welding process.

Key points of inspection for welding process & examples of bad processing.

Key points of inspection:

- ① .The pin position shall be welded correctly.
- ② .The welding spot shall be smooth, glossy and without such defects as cold joint, icicle, short circuit and tin peeling.
- ③ .The wire core shall be intact without bare wire or wound caused by burning or pinching.
- ④ .The connector shall not be scalded.
- ⑤ .The butt contact of connector shall not have any displacement.

### Control on welding process

#### 1. Crimping tools



#### 2. Judgment criterion

Crimping requirements:

- ① . Before assembling the shell, check the intermediate crimping between the inspection hole and the terminal through which the wire enters into.
- ② .The indentation after crimping shall surround the pin with enough depth.

#### Inspection stations

- ① Inspection before assembling the shell
- ② . Inspection after assembling the shell
- ③ . Inspection before delivery

Project Cases

Wind power project

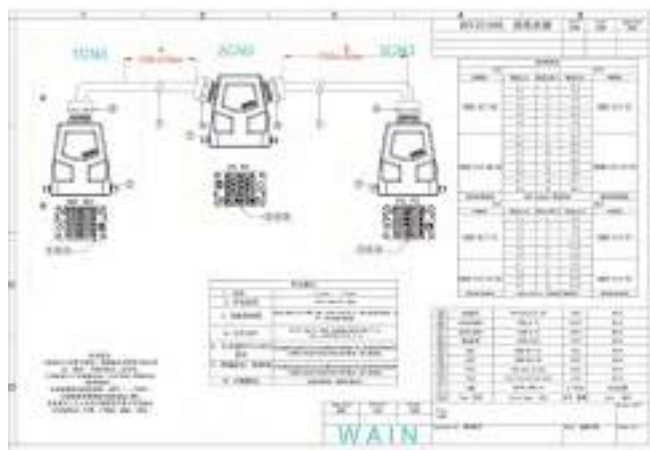
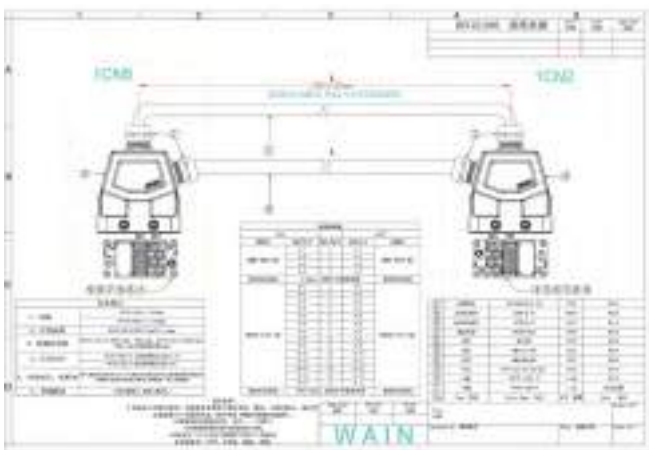
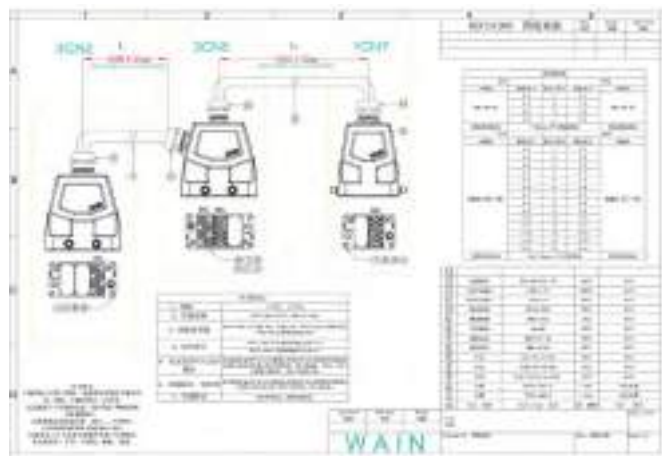
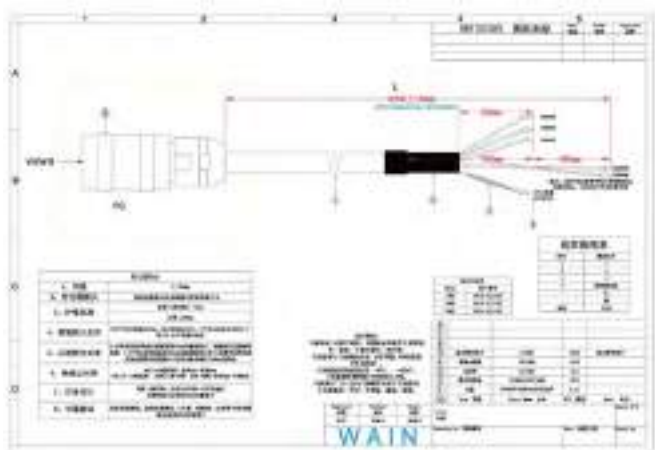
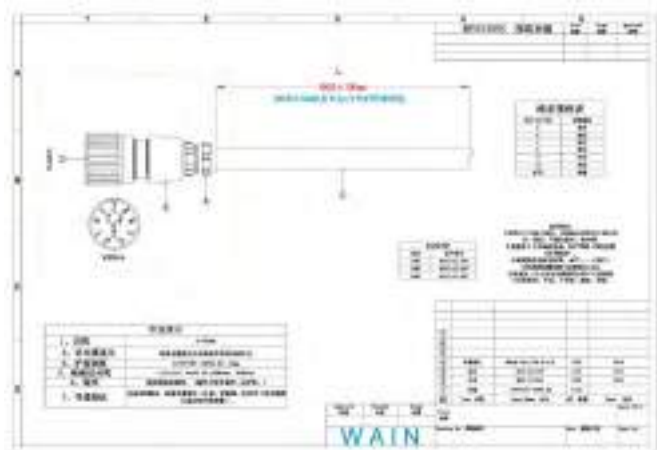



Project Cases

Electrical appliance connecting wire project

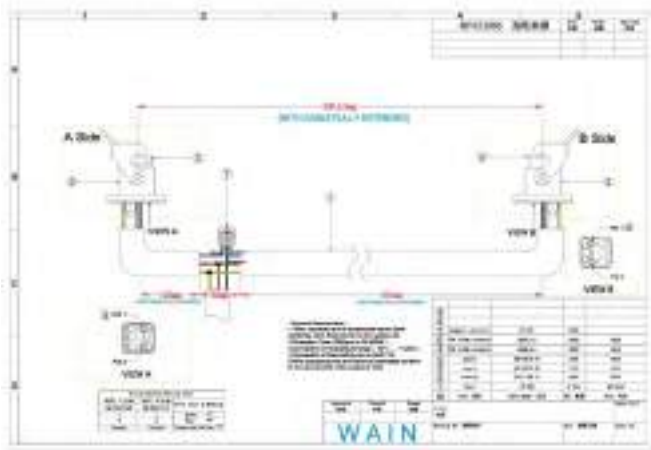
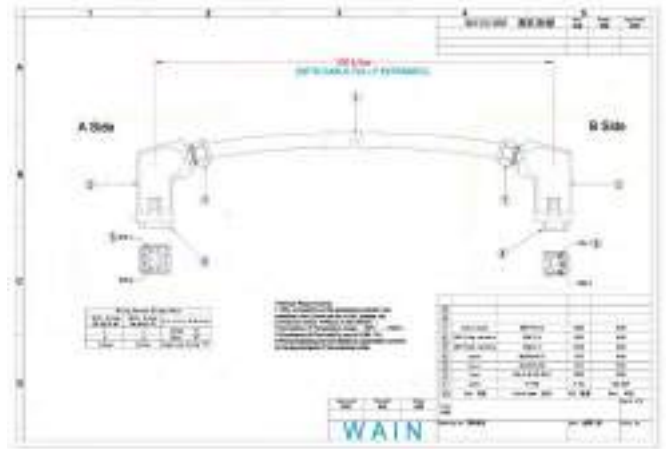
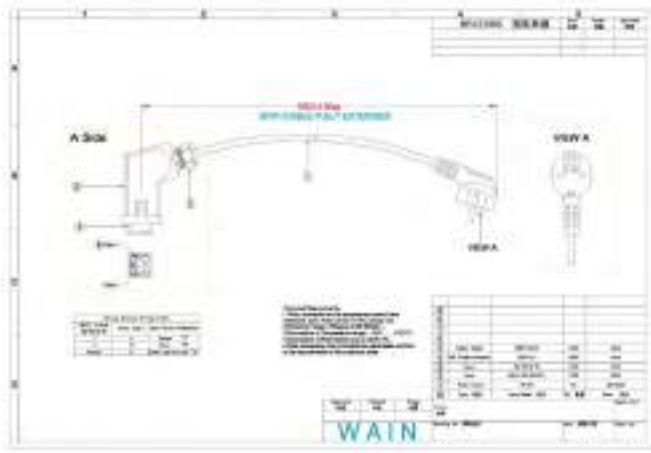

Project Cases

Railway jumper wire project

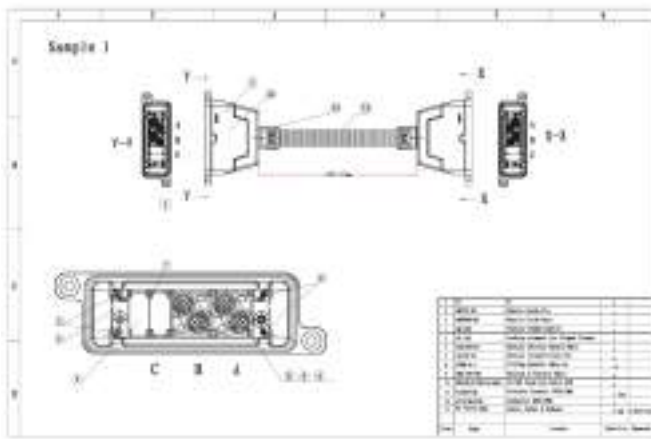

Project Cases

Automobile production line

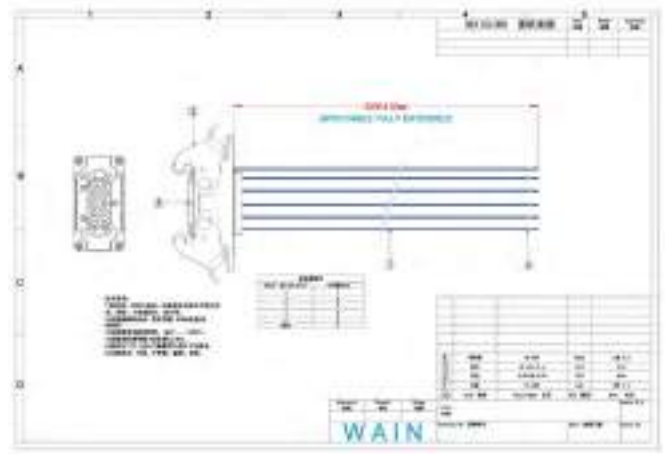
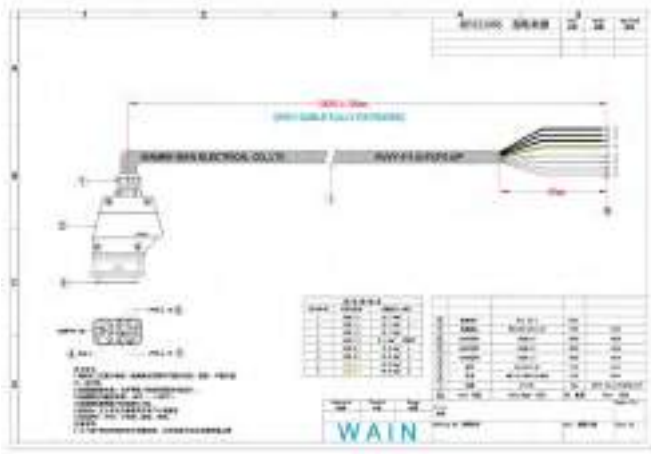
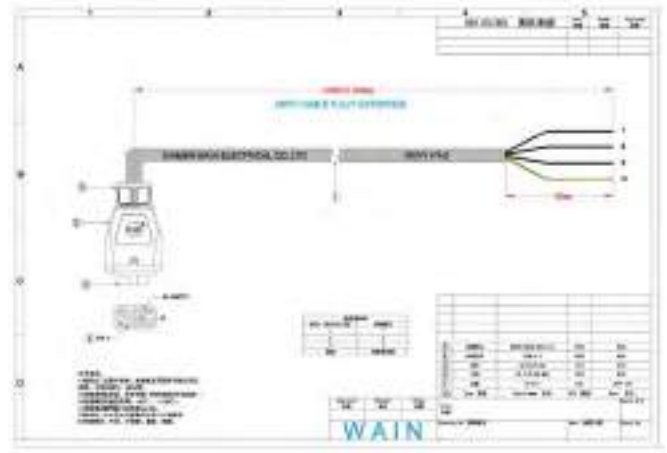
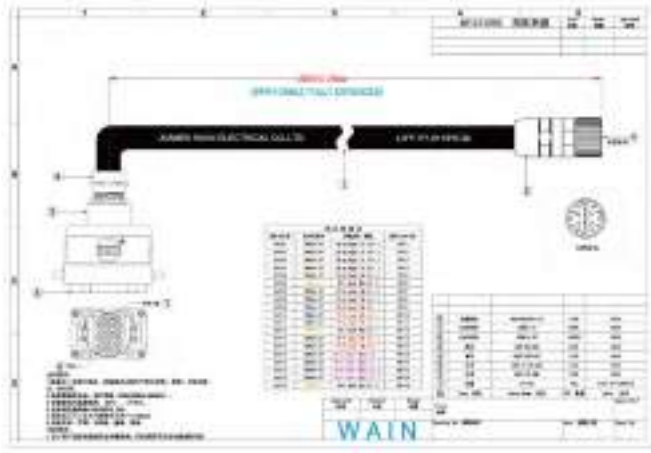

Project Cases

Automobile production line

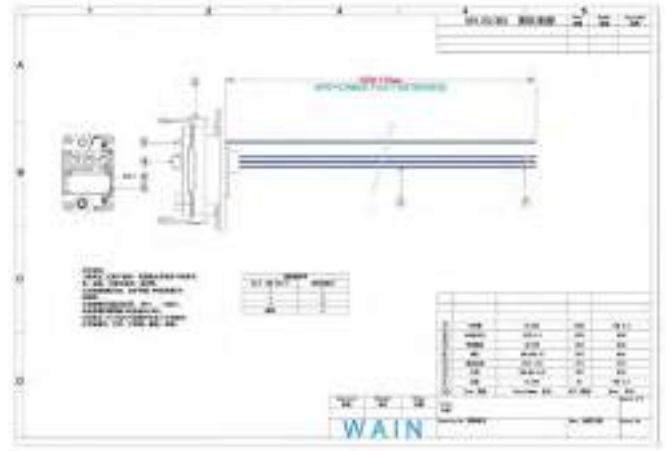
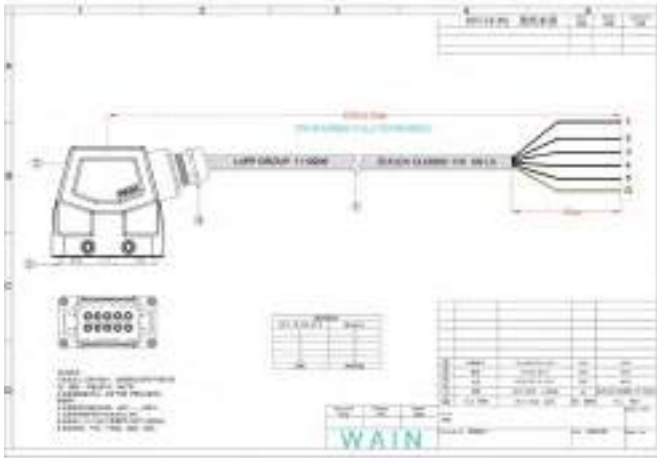

## Rectangular crimping type

Customized service Crimping Inter-cabinet wire

### Free length

Selection of connector: Firstly, select the insert; secondly, select the suitable hood; lastly, select the cable gland.

#### Identification



Type of inserts	Number of contacts	Diagrammatic drawing	Hoods&Housings <sup>1)</sup>	Type of cable	Designated unit
GCHA Rectangular-crimping HA Series	3 4 46 ... Select the number of contacts as required. See P00-01		MC1D male · 1 lever top-entry MC2D male · 2 lever top-entry FC1D female · 1 lever top-entry FC2D female · 2 lever top-entry MCHD male · tight top-entry	CCC CE UL VDE  According to the cable designated by clients!	0.2-50m Designated unit 0.1m
GCHE Rectangular-crimping HE Series			MT1D male · 1 lever top-entry MT2D male · 2 lever top-entry FT1D female · 1 lever top-entry FT2D female · 2 lever top-entry MTHD male · tight top-entry		
GCHVE Rectangular-crimping HVE Series			MC1C male · 1 lever side-entry MC2C male · 2 lever side-entry FC1C female · 1 lever side-entry FC2C female · 2 lever side-entry MCHC female · tight side-entry		
GCHD Rectangular-crimping HD&HDD Series			MT1C male · 1 lever side-entry MT2C male · 2 lever side-entry FT1C female · 1 lever side-entry FT2C female · 2 lever side-entry MTHC female · tight side-entry		
GCHK Rectangular-crimping HK Series			Select right shell size and cable gland according to the core!		
GCHM Rectangular-crimpingHM Series					
GCHQ Rectangular-crimping HQ Series					
GCHC Rectangular-crimpingHC Series					

1) Double-ended wiring harness: MC1D: male 1 lever top-entry, MMC1D: male · male 1 lever top-entry, MFC1D: male · female 1 lever top-entry; for multi-ended wiring harness or special products, please directly contact the wiring harness department of our company.

## Rectangular screwing type

Customized service Crimping Inter-cabinet wire

### Free length

Selection of connector: Firstly, select the insert; secondly, select the suitable hood; lastly, select the cable gland.

#### Identification



Type of inserts	Number of contacts	Diagrammatic drawing	Hoods&Housings <sup>1)</sup>	Type of cable	Designated unit	
GLHA Rectangular screwing HA Series	Select the number of contacts as required. See P00-01		MC1D male · 1 lever top-entry MC2D male · 2 lever top-entry FC1D female · 1 lever top-entry FC2D female · 2 lever top-entry MCHD male · tight top-entry	CCC CE UL VDE	0.2-50m Designated unit 0.1m	
GLHE Rectangular screwing HE Series						
GLHVE Rectangular screwing HVE Series			MT1D male · 1 lever top-entry MT2D male · 2 lever top-entry FT1D female · 1 lever top-entry FT2D female · 2 lever top-entry MTHD male · tight top-entry			
GLHSB Rectangular screwing HSB Series			3 6 46			
GLHK Rectangular screwing HK Series						
GLHEAV Rectangular screwing HEAV Series			MC1C male · 1 lever side-entry MC2C male · 2 lever side-entry FC1C female · 1 lever side-entry FC2C female · 2 lever side-entry MCHC female · tight side-entry			According to the cable designated by clients!
GLHM Rectangular screwing HM Series						
GLHQ Rectangular screwing HQ Series						
GLHC Rectangular screwing HC Series						
		MT1C male · 1 lever side-entry MT2C male · 2 lever side-entry FT1C female · 1 lever side-entry FT2C female · 2 lever side-entry MTHC female · tight side-entry	Select right shell size and cable gland according to the core!			

1) Double-ended wiring harness: MC1D: male 1 lever top-entry, MMC1D: male · male 1 lever top-entry, MFC1D: male · female 1 lever top-entry; for multi-ended wiring harness or special products, please directly contact the wiring harness department of our company.

## Rectangular spring type

Customized service spring Inter-cabinet wire

### Free length

Selection of connector: Firstly, select the insert; secondly, select the suitable hood; lastly, select the cable gland.

#### Identification



Type of inserts	Number of contacts	Diagrammatic drawing	Hoods&Housings <sup>1)</sup>	Type of cable	Designated unit
GTHA Rectangular-spring HA Series	3 4 46 ... Select the number of contacts as required. See P00-01		MC1D male-1 lever top-entry MC2D male-2 lever top-entry FC1D female-1 lever top-entry FC2D female-2 lever top-entry MCHD male-tight top-entry	CCC CE UL VDE  According to the cable designated by clients!	0.2-50m Designated unit 0.1m
GTHE Rectangular-spring HE Series			MT1D male-1 lever top-entry MT2D male-2 lever top-entry FT1D female-1 lever top-entry FT2D female-2 lever top-entry MTHD male-tight top-entry		
GTHVE Rectangular-spring HVE Series			MC1C male-1 leverside-entry MC2C male-2 lever side-entry FC1C female-1 lever side-entry FC2C female-2 lever side-entry MCHC female-tight side-entry		
GTHVES Rectangular-spring HVES Series			MT1C male-1 leverside-entry MT2C male-2 lever side-entry FT1C female-1 lever side-entry FT2C female-2 lever side-entry MTHC female-tight side-entry		
GTHM Rectangular-spring HM Series			Select right shell size and cable gland according to the core!		

1) Double-ended wiring harness: MC1D: male 1 lever top-entry, MMC1D: male • male 1 lever top-entry, MFC1D: male • female 1 lever top-entry; for multi-ended wiring harness or special products, please directly contact the wiring harness department of our company.

Circular crimping type

Customized service Crimping Inter-cabinet wire

Free length

Selection of connector: Firstly, select the insert; secondly, select the suitable hood; lastly, select the cable gland.

Identification



Type of inserts	Number of contacts	Diagrammatic drawing	Hoods&Housings <sup>1)</sup>	Type of cable	Designated unit
YCHR23 circular crimping HR23 Series	12 17		MCD male top-entry FCD female top-entry	CCC CE UL VDE  According to the cable designated by clients!	0.2-50m Designated unit 0.1m
			MTD male top-entry FTD female top-entry		
			MCS male 90°C entry FCS female 90°C entry		
			MTS male 90°C entry FTS female 90°C entry		
			Select right shell size and cable gland according to the core!		

1) Double-ended wiring harness: MC1D: male 1 lever top-entry, MMC1D: male • male 1 lever top-entry, MFC1D: male • female 1 lever top-entry; for multi-ended wiring harness or special products, please directly contact the wiring harness department of our company.

## Circular spring type

Customized service screwing Inter-cabinet wire

## Free length

Selection of connector: Firstly, select the insert; secondly, select the suitable hood; lastly, select the cable gland.

## Identification

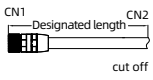
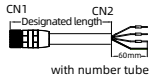
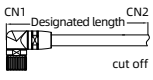
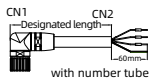
Identification	Type of inserts	Number of contacts	Diagrammatic drawing	Hoods&Housings <sup>1)</sup>	Type of cable	Designated unit
	YLHR23 Circular-screwing HR23 Series	3 4 12 ...		MCD male·top-entry FCD female·top-entry	CCC CE UL VDE  According to the cable designated by clients!	0.2-50m Designated unit 0.1m
	YLM8 Circular-screwing M8 Series	...		MTD male·top-entry FTD female·top-entry		
	YLM12 Circular-screwing M12 Series	Select the number of contacts as required. See P00-02		MCS male90°C entry FCS female90°C entry		
				MTS male90°C entry FTS female90°C entry		

1) Double-ended wiring harness: MC1D: male 1 lever top-entry, MMC1D: male • male 1 lever top-entry, MFC1D: male • female 1 lever top-entry; for multi-ended wiring harness or special products, please directly contact the wiring harness department of our company.



Circular welding type

Customized service welding Inter-cabinet wire

Free length

Selection of connector: Firstly, select the insert; secondly, select the suitable hood; lastly, select the cable gland.

Identification



Type of inserts	Number of contacts	Diagrammatic drawing	Hoods&Housings <sup>1)</sup>	Type of cable	Designated unit
			MCD male·top-entry FCD female·top-entry		
YTHR23 Circular-welding HR23 Series	3		MTD male·top-entry FTD female·top-entry	CCC	0.2-50m Designated unit 0.1m
YTM8 Circular-welding M8 Series	6			CE	
YTM12 Circular-welding M12 Series	12			UL	
	...	Select the number of contacts as required. See P00-02	VDE		
			MCS male90°C entry FCS female90°C entry	According to the cable designated by clients!	
			MTS male90°C entry FTS female90°C entry	Select right shell size and cable gland according to the core!	

1)Double-ended wiring harness: MC1D:male 1 lever top-entry, MMC1D: male • male 1 lever top-entry, MFC1D: male • female 1 lever top-entry; for multi-ended wiring harness or special products, please directly contact the wiring harness department of our company.

## Optical fiber SERIES



# ODC

## Optical fiber connector



Technical characteristics	
Insertion loss	$\leq 0.70$ dB (typical value 0.4dB)
Return loss	40dB
Number of optical fiber cores	4, 8, 12, 24
Mechanical working life (mating cycles)	$\geq 500$
Vibrate	10-50HZ, 10g
Shock	100g
Limiting temperatures	Normal -20°C ... +75°C
	Special -40°C ... +85°C
Degree of protection	IP67

### Technical characteristics

ODC series of outdoor optical fiber connector has solid structure and reliable connection, and is waterproof and dustproof. It is extensively used in the optical transmission and connection under severe outdoor environment like sensing and power.

1. Screw-threaded locking mechanism guarantees long-term and reliable connection.
2. Guide mechanism enables blind insertion with single hand, making the installation easy and quick.
3. Sealing design makes the connector waterproof, dustproof (IP67) and anti-corrosive.
4. Compact, easy to operate, solid and durable.
5. Applicable to single-mode or multimode optical fiber.

### Naming Rule

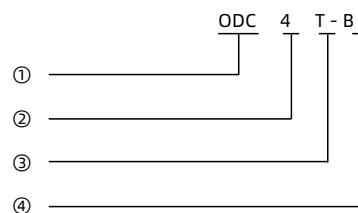

- ① (ODC): Name of Series
- ② (4): Number of pins of optical fiber plug (4, 8, 12, 24)
- ③ (T): T: Plug, Z: Socket
- ④ (B): B-Aluminum alloy oxidized into black  
N-Chemical nickel-plating of aluminum alloy  
K-Passivation of stainless steel

## Optical fiber SERIES

### Optical fiber SERIES

#### 4 pins Optical fiber connector

Multiple kinds of optical fiber plug can be connected at the end, for example, FC, SC, ST, LC, etc. or optical plug or socket.

Connector	Description	Designation
Plug	Aluminum alloy oxidized into black	ODC4T-B
	Chemical nickel-plating of aluminum alloy	ODC4T-N
	Passivation of stainless steel	ODC4T-K
Socket	Aluminum alloy oxidized into black	ODC4Z-B
	Chemical nickel-plating of aluminum alloy	ODC4Z-N
	Passivation of stainless steel	ODC4Z-K

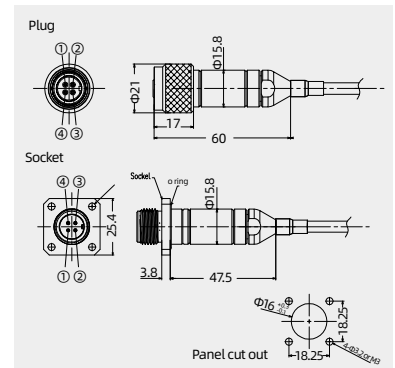

#### 8 pins Optical fiber connector

Multiple kinds of optical fiber plug can be connected at the end, for example, FC, SC, ST, LC, etc. or optical plug or socket.

Connector	Description	Designation
Plug	Aluminum alloy oxidized into black	ODC8T-B
	Chemical nickel-plating of aluminum alloy	ODC8T-N
	Passivation of stainless steel	ODC8T-K
Socket	Aluminum alloy oxidized into black	ODC8Z-B
	Chemical nickel-plating of aluminum alloy	ODC8Z-N
	Passivation of stainless steel	ODC8Z-K

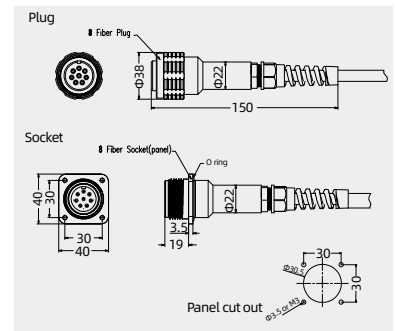

#### 12 pins Optical fiber connector

Multiple kinds of optical fiber plug can be connected at the end, for example, FC, SC, ST, LC, etc. or optical plug or socket.

Connector	Description	Designation
Plug	Aluminum alloy oxidized into black	ODC12T-B
	Chemical nickel-plating of aluminum alloy	ODC12T-N
	Passivation of stainless steel	ODC12T-K
Socket	Aluminum alloy oxidized into black	ODC12Z-B
	Chemical nickel-plating of aluminum alloy	ODC12Z-N
	Passivation of stainless steel	ODC12Z-K

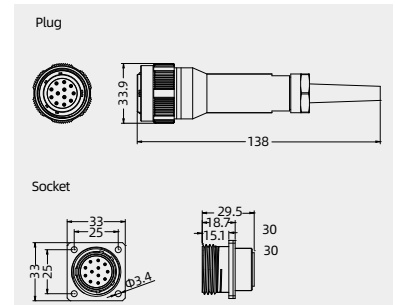

#### 24 pins Optical fiber connector

Multiple kinds of optical fiber plug can be connected at the end, for example, FC, SC, ST, LC, etc. or optical plug or socket.

Connector	Description	Designation
Plug	Aluminum alloy oxidized into black	ODC24T-B
	Chemical nickel-plating of aluminum alloy	ODC24T-N
	Passivation of stainless steel	ODC24T-K
Socket	Aluminum alloy oxidized into black	ODC24Z-B
	Chemical nickel-plating of aluminum alloy	ODC24Z-N
	Passivation of stainless steel	ODC24Z-K

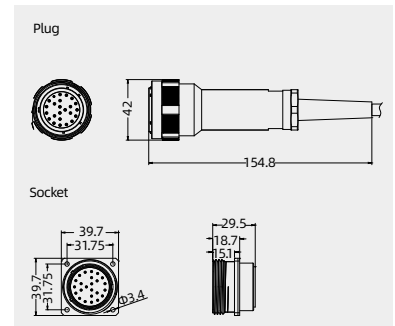

## Prefabricated optical cable

Optical fiber connector is generally ordered as the component of prefabricated optical cable. Our standard configuration is non-metal mouseproof cable (62.5/125) reinforced with glass fiber. Other customized cables are also available.



### Naming Rule

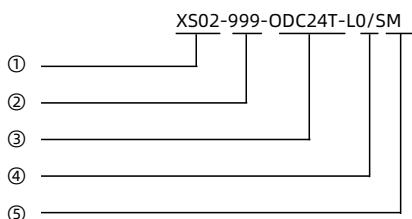

- ① XS02: Double-end prefabrication
- ② 999: Feature flow number, with 999 means no special requirement
- ③ ODC24TN: Model of optical fiber connector
- ④ L0: Length of prefabricated optical fiber
- ⑤ SM: Single-mode optical fiber 9/125

### Drawing

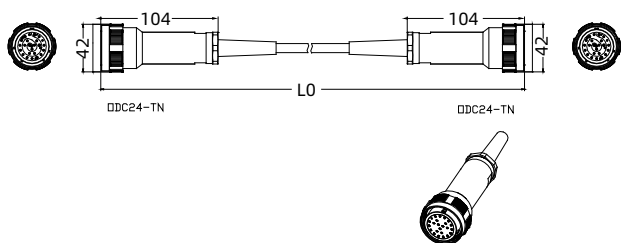

### Naming Rule

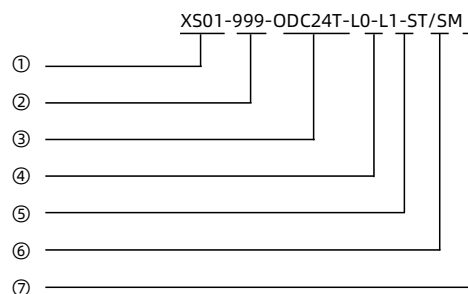

- ① XS01: Single-end prefabrication
- ② 999: Feature flow number, with 999 means no special requirement
- ③ ODC24TN: Model of optical fiber connector
- ④ L0: Length of prefabricated optical fiber
- ⑤ L1: Length of pigtail cable
- ⑥ ST: means that ST flange base is configured
- ⑦ SM: Single-mode optical fiber 9/125

### Drawing

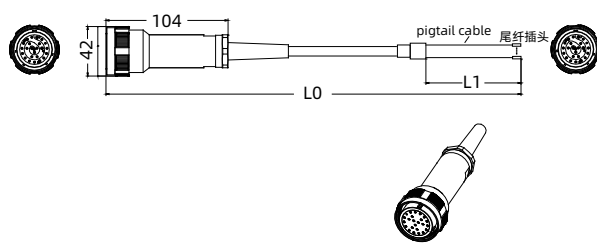

## Tools/Cable glands



## Production Recommendations: Aluminium Alloy Cable Gland



### Advantages of Aluminium Alloy Cable Gland :

1. Light weight
2. Low material costs
3. Anti-oxidation and anti-corrosion

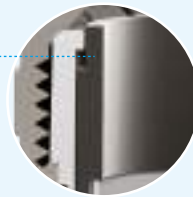

#### Variable sealing ring

One model of variable sealing ring could cover a wide range of cables with different diameter.

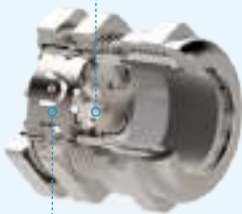

#### Low contact resistance

The jaw on the spring strip has several contact, larger contact area maximizes the shielded area.

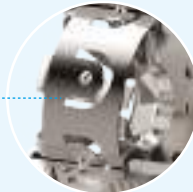

#### Flexible wiring methods

If 360 degree contact is necessary, the shielding layer should be trimmed before being wrapped with copper foil or aluminium foil , such assembly process could guarantee reliable contact under shielding layer.

More information about aluminium alloy cable gland, please refer to P32-12.

## Tools

### Contact removal tools

#### D-sub Contact removal tools



Application	Designation	Order NO.
for 5A crimp contacts	TL08	198 001 000 0006

#### HD Contact removal tools



Application	Designation	Order NO.
for 10A crimp contacts and 16A male contacts (with spring clip retention)	TL00	198 001 000 0001

#### HD Contact removal tools

Origin: Germany



Application	Designation	Order NO.
for 10A crimp contacts and 16A male contacts (with spring clip retention)	TL00G	198 001 000 0016

#### HEE Contact removal tools



Application	Designation	Order NO.
for 16A crimp contacts	TL01	198 001 000 0002

#### HEE Contact removal tools

Origin: Germany



Application	Designation	Order NO.
for 16A crimp contacts	TL01G	198 001 000 0017

#### HEE Contact removal tools



Application	Designation	Order NO.
16A female contacts (with spring clip retention)	TL09	198 001 000 0015

### Contact Insertion Tool

#### Contact Insertion Tool



Application	Designation	Order NO.
the auxiliary pin assembly tool of 10A/16A	TL15	198 001 000 0026



## Tools

## Contact removal tools

## Contact removal tools



Application	Designation	Order NO.
for 10A female contacts	TL13	198 001 000 0025

## Contact removal tools

Origin: Germany



Application	Designation	Order NO.
for 40A crimp contacts	TL06G	198 001 000 0009

## Contact removal tools



Application	Designation	Order NO.
H2MK-002 inserts	TL07	198 001 000 0011

## Contact removal tools



Application	Designation	Order NO.
HMK-001 inserts	TL11	198 001 000 0018

## Contact removal tools



Application	Designation	Order NO.
for locking sleeve, H2MVC-002 inserts , H2MVE-002 inserts	TL10	198 001 000 0014

## Contact removal tools



Application	Designation	Order NO.
for HK-004/4 inserts	TL12	198 001 000 0024

## Contact removal tools



Application	Designation	Order NO.
for HMP-003-V2 Metal Pneumatic Module	TL26	198 001 000 0030

Tools

Contact removal tools



Application	Designation	Order NO.
for 40A crimp contacts	TL06	198 001 000 0005

Crimp Contact removal tools



Application	Designation	Order NO.
PCB crimp inserts	TL-BR	198 001 000 0040

Contact removal tools



Application	Designation	Order NO.
Coaxial Module H2MC-012 HMC-004	TL29	198 001 000 0041

## Tools

## Crimping tools

## 5A Crimping tool



Wire gauge	Designation	Order NO.
0.09-0.82mm <sup>2</sup>	TL03	198 001 001 0002

## 10A/16A Crimping tool



Wire gauge	Designation	Order NO.
0.14-4mm <sup>2</sup>	TL02	198 001 001 0001
1.5-6mm <sup>2</sup>	TL02-0	198 001 001 0006

## 10A/16A/40A Crimping tool

Origin: Germany



Wire gauge	Designation	Order NO.
0.14-4mm <sup>2</sup> (10A/16A)	TL02G	198 001 001 0011
1.5-6mm <sup>2</sup> (40A)	TL02-0G	198 001 001 0012
4/6/10mm <sup>2</sup> (16A/40A)	TL02-3G	198 001 001 0013

Not suitable for contact with 16A,0.37mm<sup>2</sup>

## 10A/16A/40A Crimping tool with digital display

Origin: Germany



Wire gauge	Designation	Order NO.
0.14-6mm <sup>2</sup>	TL02-2G	198 001 001 0014

## 100A-650A manual hydraulic clamp



Description	Wire gauge	Designation	Order NO.
Output: automatic pressure release	10-240mm <sup>2</sup>	TL05	198 001 001 0005
Output: 13T			
Weight: 6.2kg			

## 100A-650A High current electro-hydraulic pliers



Wire gauge	Designation	Order NO.
10-300mm <sup>2</sup>	TL05-EA	198 001 001 0020

## 100A-650A manual hydraulic clamp

Origin: Sweden



Wire gauge	Designation	Order NO.
10-240mm <sup>2</sup>	TL05G	198 001 001 0019

100A-650A High current electro-hydraulic pliers  
Origin: Sweden

Wire gauge	Designation	Order NO.
10-240mm <sup>2</sup>	TL05G-EA	198 001 001 0021

## Crimping pliers



Wire gauge	Designation	Order NO.
	TL31	198 001 001 0041

## Tools

## Crimping tools

## 10A/16A/40A Crimping tool



Wire gauge	Designation	Order NO.
0.14-4mm <sup>2</sup>	TL28-2	198 001 001 0039
1.5-10mm <sup>2</sup>	TL28-3	198 001 001 0040

Semi-automatic crimping machine  
origin: Germany

Wire gauge	Designation	Order NO.
0.14-6.0mm <sup>2</sup>	CM25-3	198 001 002 0002

## HE B spring open machine



Description	Designation	Order NO.
for all HE B spring inserts	SOM01	198 001 003 0008

## 5A Pneumatic cold pressing pliers

Suitable for mass pressure welding and improve the efficiency of field wiring greatly.



Wire gauge	Designation	Order NO.
0.25-0.82mm <sup>2</sup>	TL03-W7Q	198 001 001 0018

## 10A/16A Pneumatic cold pressing

pliers Suitable for mass pressure welding and improve the efficiency of field wiring greatly.



Wire gauge	Designation	Order NO.
0.37-4.0mm <sup>2</sup>	TL02-WA27F	198 001 001 0016

## 40A Pneumatic cold pressing pliers

Suitable for mass pressure welding and improve the efficiency of field wiring greatly.



Wire gauge	Designation	Order NO.
1.5-10mm <sup>2</sup>	TL02-W4Q	198 001 001 0017

Install the connection here: :

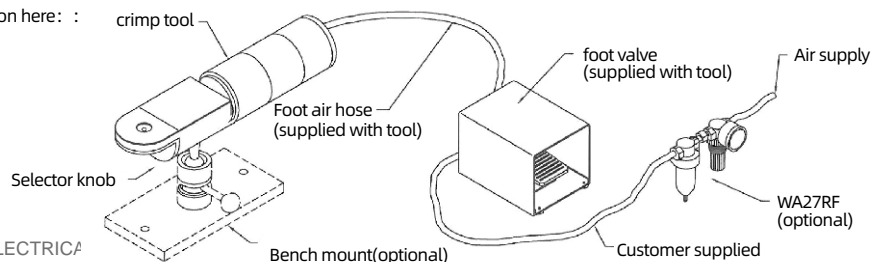

## Cable glands

## Metal cable gland

Material: Nickel-plate brass

Sealing: Nylon and NBR

Degree of protection: IP68(with O-sealing)

Temperature range: Stat: -40°C ...+100°C

Dyn: -20°C ...+80°C

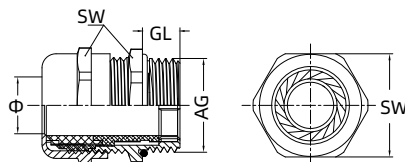

Unit: mm

Thread side	Clamping range(Φ)	Thread diameter(AG)	Wrench size(SW)	Thread length(GL)	Designation	Order NO.
<b>PG Thread</b>						
PG7	3-6.5	12.5	14	6	WNA-PG7(D3-6.5) <sup>1)</sup>	102 107 001 1001
PG9	4-8	15.2	17	6.5	WNA-PG9(D4-8) <sup>1)</sup>	102 107 002 1001
PG11	4-8	18.6	20	7	WNA-PG11(D4-8)	102 107 018 1504
PG11	5-10	18.6	20	7	WNA-PG11(D5-10)	102 107 003 1001
PG13.5	6-12	20.4	22	7.5	WNA-PG13.5(D6-12)	102 107 004 1001
PG16	8-14	22.5	24	7	WNA-PG16(D8-14)	102 107 005 1001
PG21	13-18	28.3	30	8	WNA-PG21(D13-18)	102 107 006 1001
PG29	18-25	37.0	40	9	WNA-PG29(D18-25)	102 107 007 1001
PG36	22-32	47.0	50	12	WNA-PG36(D22-32)	102 107 008 1001
PG42	31-38	54.0	57	12	WNA-PG42(D31-38)	102 107 009 1001
PG48	37-44	59.3	65	12	WNA-PG48(D37-44) <sup>3)</sup>	102 107 010 1001
<b>Metric Thread</b>						
M12x1.5	3-6.5	12	14	6	WNA-M12(D3-6.5) <sup>1)</sup>	102 107 011 1001
M14x1.5	3-6.5	14	14	6	WNA-M14(D3-6.5) <sup>1)</sup>	102 107 012 1001
M16x1.5	4-8	16	17	6.5	WNA-M16(D4-8) <sup>1)</sup>	102 107 013 1001
M16x1.5	5-10	16	20	6	WNA-M16(D5-10) <sup>1)</sup>	102 107 013 1002
M18x1.5	5-10	18	20	7	WNA-M18(D5-10) <sup>1)</sup>	102 107 014 1001
M20x1.5	4-8	20	22	8	WNA-M20(D4-8)	102 107 018 1503
M20x1.5	6-12	20	22	8	WNA-M20(D6-12)	102 107 015 1001
M20x1.5	8-14	20	24	8	WNA-M20(D8-14)	102 107 015 1002
M22x1.5	8-14	22	24	7.5	WNA-M22(D8-14)	102 107 016 1001
M25x1.5	9-16	25	27	7.5	WNA-M25(D9-16)	102 107 018 1002
M25x1.5	13-18	25	30	7.5	WNA-M25(D13-18)	102 107 018 1001
M32x1.5	15-22	32	35	8.5	WNA-M32(D15-22)	102 107 019 1002
M32x1.5	18-25	32	40	8.0	WNA-M32(D18-25)	102 107 019 1001
M40x1.5	18-25	40	45	12	WNA-M40(D18-25)	102 107 020 1002
M40x1.5	22-32	40	50	12	WNA-M40(D22-32)	102 107 020 1001
M50x1.5	22-32	50	57	12	WNA-M50(D22-32)	102 107 046 1002
M50x1.5	31-38	50	57	12	WNA-M50(D31-38)	102 107 046 1001
M63x1.5	37-44	63	65	12	WNA-M63(D37-44)	102 107 048 1001

1).MOQ 100 pcs. 2).MOQ 200 pcs. 3).MOQ 50 pcs. 4).MOQ 20 pcs.

## Cable glands

## Metal cable gland

Material: Nickel-plate brass

Sealing: TPR

Degree of protection: IP68(with O-sealing)

Temperature range: Stat: -40°C ...+100°C

Dyn: -40°C ...+120°C

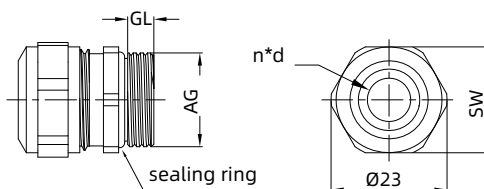

Unit: mm

Thread side	Clamping range( $\Phi$ )	Thread diameter(AG)	Wrench size(SW)	Thread length(GL)	Designation	Order NO.
PG Thread						
PG11	1 $\times$ $\Phi$ 5.5	18.6	21	5.2	WNA/A-PG11(D4-5.5)	102 100 003 0500
PG11	1 $\times$ $\Phi$ 8.6	18.6	21	5.2	WNA/A-PG11(D5.5-12)	102 100 003 0502
PG11	2 $\times$ $\Phi$ 5	18.6	21	5.2	WNAM/A-PG11(2*D3.5-5)	102 100 003 0501
PG11	2 $\times$ $\Phi$ 6	18.6	21	5.2	WNAM/A-PG11/(2*D4.5-6)	102 100 004 0500
PG11	2 $\times$ $\Phi$ 7.5	18.6	24	5.2	WNAM/A-PG11(2*D5.5-7.5)	102 100 003 1502
PG11	3 $\times$ $\Phi$ 5	18.6	21	5.2	WNAM/A-PG11/(3*D3.5-5.0)	102 100 003 1503

1).MOQ 100 pcs. 2).MOQ 200 pcs. 3).MOQ 50 pcs. 4).MOQ 20 pcs.

## Cable glands

## Metal cable gland-extra length

Material: Nickel-plate brass

Sealing: Nylon and NBR

Degree of protection: IP68(with O-sealing)

Temperature range: Stat: -40°C ...+100°C

Dyn: -20°C ...+80°C

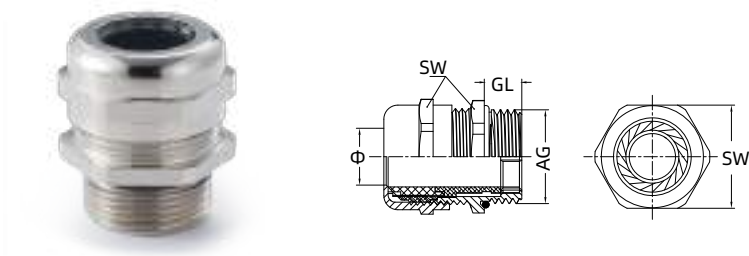

Unit: mm

Thread side	Clamping range( $\Phi$ )	Thread diameter(AG)	Wrench size(SW)	Thread length(GL)	Designation	Order NO.
Metric Thread						
M25x1.5	9-16	25	27	12	WNA-M25L(D9-16) <sup>3)</sup>	102 107 018 1102
M25x1.5	13-18	25	30	12	WNA-M25L(D13-18) <sup>3)</sup>	102 107 018 1101
M32x1.5	15-22	32	35	12	WNA-M32L(D15-22) <sup>3)</sup>	102 107 019 1102
M32x1.5	18-25	32	40	12	WNA-M32L(D18-25) <sup>3)</sup>	102 107 019 1101
M40x1.5	22-32	40	50	15	WNA-M40L(D22-32) <sup>3)</sup>	102 107 020 1101

1).MOQ 100 pcs. 2).MOQ 200 pcs. 3).MOQ 50 pcs. 4).MOQ 20 pcs.

## Cable glands

## Plastic cable gland

Material: Nylon

Sealing: NBR

Degree of protection: IP68(with O-sealing)

Temperature range: Stat: -40°C ...+100°C

Dyn: -20°C ...+80°C

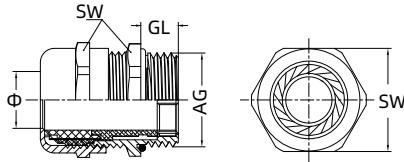

Unit: mm

Thread side	Clamping range(Φ)	Thread diameter(AG)	Wrench size(SW)	Thread length(GL)	Designation(Grey)	Order NO.	Designation(Black)	Order NO.
<b>PG Thread</b>								
PG7	3-6.5	12.5	15	8.5	WNAP-PG7G(D3-6.5) <sup>1)</sup>	102 108 001 2001	WNAP-PG7B(D3-6.5) <sup>1)</sup>	102 108 001 2002
PG9	4-8	15.2	19	8.0	WNAP-PG9G(D4-8) <sup>1)</sup>	102 108 002 2001	WNAP-PG9B(D4-8) <sup>1)</sup>	102 108 002 2002
PG11	5-10	18.6	22	8.0	WNAP-PG11G(D5-10)	102 108 003 2001	WNAP-PG11B(D5-10)	102 108 003 2002
PG13.5	6-12	20.4	24	10	WNAP-PG13.5G(D6-12)	102 108 004 2001	WNAP-PG13.5B(D6-12)	102 108 004 2002
PG16	8-14	22.5	27	10	WNAP-PG16G(D8-14)	102 108 005 2001	WNAP-PG16B(D8-14)	102 108 005 2002
PG21	13-18	28.3	33	11	WNAP-PG21G(D13-18)	102 108 006 2001	WNAP-PG21B(D13-18)	102 108 006 2002
PG29	18-25	37.0	42	11	WNAP-PG29G(D18-25)	102 108 007 2001	WNAP-PG29B(D18-25)	102 108 007 2002
PG36	22-32	47.0	52	13	WNAP-PG36G(D22-32)	102 108 008 2001	WNAP-PG36B(D22-32)	102 108 008 2002
PG42	32-38	54.0	60	15	WNAP-PG42G(D32-38)	102 108 009 2001	WNAP-PG42B(D32-38)	102 108 009 2002
PG48	37-44	59.3	65	14.0	WNAP-PG48G(D37-44) <sup>1)</sup>	102 108 010 2001	WNAP-PG48B(D37-44) <sup>1)</sup>	102 108 010 2002
<b>Metric Thread</b>								
M12x1.5	3-6.5	12	15	8	WNAP-M12G(D3-6.5) <sup>1)</sup>	102 108 011 2001	WNAP-M12B(D3-6.5) <sup>1)</sup>	102 108 011 2002
M16x1.5	4-8	16	19	8	WNAP-M16G(D4-8) <sup>1)</sup>	102 108 013 2001	WNAP-M16B(D4-8) <sup>1)</sup>	102 108 013 2002
M20x1.5	5-10	20	24	9	WNAP-M20G(D5-10)	102 108 015 2003	WNAP-M20B(D5-10)	102 108 015 2004
M20x1.5	6-12	20	24	9	WNAP-M20G(D6-12)	102 108 015 2001	WNAP-M20B(D6-12)	102 108 015 2002
M22x1.5	8-14	22	27	10	WNAP-M22G(D8-14) <sup>1)</sup>	102 108 016 2001	WNAP-M22B(D8-14) <sup>1)</sup>	102 108 016 2002
M25x1.5	13-18	25	33	11	WNAP-M25G(D13-18)	102 108 018 2001	WNAP-M25B(D13-18)	102 108 018 2002
M32x1.5	18-25	32	42	11	WNAP-M32G(D18-25)	102 108 019 2001	WNAP-M32B(D18-25)	102 108 019 2002
M40x1.5	22-32	40	51	13	WNAP-M40G(D22-32)	102 108 020 2001	WNAP-M40B(D22-32)	102 108 020 2002
M50x1.5	22-32	50	60	13	WNAP-M50G(D22-32)	102 108 046 2500	WNAP-M50B(D22-32)	102 108 046 2501
M50x1.5	31-38	50	60	13	WNAP-M50G(D31-38)	102 108 046 2001	WNAP-M50B(D31-38)	102 108 046 2002
M63x1.5	37-44	63	65	14	WNAP-M63G(D37-44)	102 108 048 2001	WNAP-M63B(D37-44) <sup>1)</sup>	102 108 048 2002

1).MOQ 100 pcs.

2).MOQ 200 pcs.

3).MOQ 50 pcs.

4).MOQ 20 pcs.



## Cable glands

## Gland with external strain relief via calmping jaws

Material: Nickel-plate brass,Nylon

Degree of protection: IP68(with O-sealing)

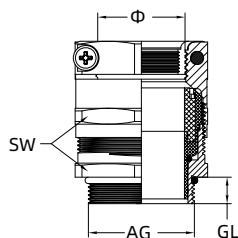

Unit: mm

Thread side	Clamping range(Φ)	Thread diameter(AG)	Wrench size(SW)	Thread length(GL)	Designation	Order NO.
PG Thread						
PG9	4-8	15.2	17	7	WNKS-PG9(4-8) <sup>3)</sup>	102 113 002 1001
PG11	5-10	18.6	22	7	WNKS-PG11(5-10)	102 113 003 1001
PG13.5	6-12	20.4	22	8	WNKS-PG13.5(6-12)	102 113 004 1001
PG16	10-14	22.5	24	7.5	WNKS-PG16(10-14)	102 113 005 1001
PG21	13-18	28.3	30	8	WNKS-PG21(13-18)	102 113 006 1001
PG29	18-25	37.0	40	9	WNKS-PG29(18-25)	102 113 007 1001
PG36	22-32	47.0	50	12	WNKS-PG36(22-32)	102 113 008 1001
PG42	30-38	54.0	57	12	WNKS-PG42(30-38)	102 113 009 1001
Metric Thread						
M16x1.5	4-8	16	18	6.5	WNKS-M16(4-8) <sup>3)</sup>	102 113 013 1001
M16x1.5	5-10	16	22	6	WNKS-M16(5-10) <sup>3)</sup>	102 113 013 1002
M20x1.5	6-12	20	22	7.5	WNKS-M20(6-12)	102 113 015 1001
M25x1.5	10-16	25	27	8	WNKS-M25(10-16)	102 113 018 1002
M25x1.5	13-18	25	30	7.5	WNKS-M25(13-18)	102 113 018 1001
M32x1.5	16-22	32	35	8.5	WNKS-M32(16-22)	102 113 019 1002
M32x1.5	18-25	32	40	8	WNKS-M32(18-25)	102 113 019 1001
M40x1.5	22-30	40	45	12	WNKS-M40(22-30)	102 113 020 1002
M40x1.5	22-32	40	50	12	WNKS-M40(22-32)	102 113 020 1001
M50x1.5	30-38	50	57	12	WNKS-M50(30-38)	102 113 046 1001

\*preferable product

1).MOQ 100 pcs. 2).MOQ 200 pcs. 3).MOQ 50 pcs. 4).MOQ 20 pcs.

## Cable glands

## Gland with external strain relief via calmping jaws

Material: Nickel-plate brass,Nylon

Degree of protection: IP68(with O-sealing)

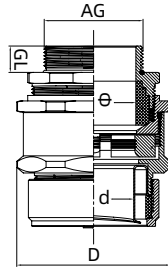

Unit: mm

Thread side	Clamping range( $\Phi$ )	Fits to tubing size(d)	Thread length(GL)	External diameter(D)	Designation	Order NO.
Metric Thread						
M25x1.5	13-18	25	8	46	WNKD-M25/D25(13-18)	102 123 018 1001
M40x1.5	22-32	38	10	70	WNKD-M40/D38(22-32)	102 123 020 1001
M45x1.5	30-38	38	10	70	WNKD-M45/D38(30-38)	102 123 041 1001

## Cable glands

## Aluminum alloy EMC cable gland

Material: Aluminum alloy

Sealing: Nylon 66 and NBR

Degree of protection: IP67(with O-sealing)

Temperature range: -40°C ...+100°C

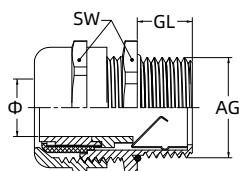

Unit: mm

Thread side	Clamping range( $\Phi$ )	Thread diameter(AG)	Wrench size(SW)	Thread length(GL)	Designation	Order NO.
Metric Thread						
M20x1.5	7-12	20	22	7	WNACAL-M20(D7-12)	102 117 015 4501
M25x1.5	7-14	25	27	9.5	WNACAL-M25(D7-14)	102 117 018 4001
M32x1.5	14-19	32	36	9.5	WNACAL-M32(D14-19)	102 117 019 4501
M32x1.5	15-22	32	36	9.5	WNACAL-M32(D15-22)	102 117 019 4502

## Cable glands

## EMC Cable gland

Material: Nickel-plate brass

Sealing: Nylon and NBR

Degree of protection: IP68(with O-sealing)

Temperature range: -40°C ...+100°C ,short-term120°C

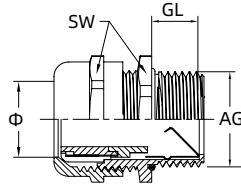

Unit: mm

Thread side	Clamping range(Φ)	Thread diameter(AG)	Wrench size(SW)	Thread length(GL)	Designation	Order NO.
PG Thread						
PG9	4-8	15.2	20	6	WNAC-PG9(D4-8) <sup>3)</sup>	102 117 002 1001
PG11	5-10	18.6	20	6	WNAC-PG11(D5-10)	102 117 003 1001
PG13.5	6-12	20.4	24	7	WNAC-PG13.5(D6-12)	102 117 004 1001
PG16	8-14	22.5	24	7	WNAC-PG16(D8-14)	102 117 005 1001
PG21	13-18	28.3	30	8	WNAC-PG21(D13-18)	102 117 006 1001
PG29	18-25	37.0	40	8	WNAC-PG29(D18-25)	102 117 007 1001
PG36	22-32	47.0	50	9	WNAC-PG36(D22-32)	102 117 008 1001
PG42	30-38	54.0	57	9	WNAC-PG42(D30-38)	102 117 009 1001
Metric Thread						
M12x1.5	3-6.5	12	14	5	WNAC-M12(D3-6.5) <sup>3)</sup>	102 117 011 1001
M16x1.5	4-8	16	20	6	WNAC-M16(D4-8) <sup>3)</sup>	102 117 013 1001
M18x1.5	5-10	18	20	6	WNAC-M18(D5-10) <sup>3)</sup>	102 117 014 1001
M20x1.5	6-12	20	24	7	WNAC-M20(D6-12)	102 117 015 1001
M24x1.5	8-14	24	27	7	WNAC-M24(D8-14) <sup>3)</sup>	102 117 017 1001
M25x1.5	10-16	25	27	12	WNAC-M25(D10-16)	102 117 018 1002
M25x1.5	13-18	25	30	13	WNAC-M25(D13-18)	102 117 018 1001
M30x1.5	13-18	30	35	8	WNAC-M30(D13-18) <sup>3)</sup>	102 117 038 1001
M32x1.5	15-22	32	40	13	WNAC-M32(D15-22)	102 117 019 1002
M32x1.5	18-25	32	40	13	WNAC-M32(D18-25)	102 117 019 1001
M36x2	18-25	36	40	8	WNAC-M36(D18-25) <sup>3)</sup>	102 117 040 1001
M40x1.5	21-30	40	45	9	WNAC-M40(D21-30)	102 117 020 1002
M40x1.5	22-32	40	50	9	WNAC-M40(D22-32)	102 117 020 1001
M48x2	22-32	48	50	9	WNAC-M48(D22-32) <sup>3)</sup>	102 117 045 1001
M50x1.5	30-38	50	57	9	WNAC-M50(D30-38) <sup>3)</sup>	102 117 046 1001
M56x2	30-38	56	57	9	WNAC-M56(D30-38) <sup>3)</sup>	102 117 047 1001
M63x1.5	37-44	63	65	10	WNAC-M63(D37-44)	102 117 048 1001

1).MOQ 100 pcs. 2).MOQ 200 pcs. 3).MOQ 50 pcs. 4).MOQ 20 pcs.

## Cable glands

## Metal cable gland with multi-core

Material: Nickel-plate brass

Sealing: Nylon and NBR

Degree of protection: IP65(with O-sealing)

Temperature range: -40°C ...+100°C ,short-term 120°C

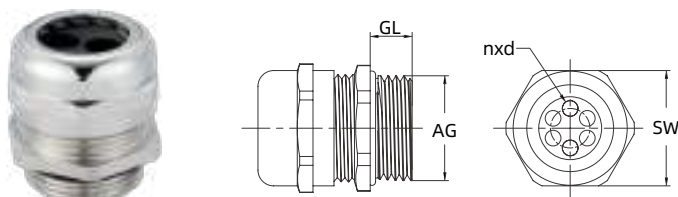

Unit: mm						
Thread side	Clamping range(Φ)	Thread diameter(AG)	Wrench size(SW)	Thread length(GL)	Designation	Order NO.
<b>PG Thread</b>						
PG9	2x3	15.2	17	6.7	WNAM-PG9/(2*3) <sup>2)</sup>	102 109 002 1001
PG21	4x6	28.3	30	8	WNAM-PG21/(4*6)	102 109 006 1005
PG21	3x7	28.3	30	8	WNAM-PG21/(3*7) <sup>3)</sup>	102 109 006 1004
PG21	2x6	28.3	30	8	WNAM-PG21/(2*6)	102 109 006 1001
PG21	2x7	28.3	30	8	WNAM-PG21/(2*7) <sup>2)</sup>	102 109 006 1002
PG21	2x8	28.3	30	8	WNAM-PG21/(2*8)	102 109 006 1003
PG29	4x9	37	40	9	WNAM-PG29/(4*9)	102 109 007 1001
PG36	5x9	47	50	12	WNAM-PG36/(5*9)	102 109 008 1001
<b>Metric Thread</b>						
M16x1.5	2x3	16	17	6.5	WNAM-M16/(2*3) <sup>2)</sup>	102 109 013 1001
M16x1.5	8x2	16	20	6	WNAM-M16/(8*2)	102 100 023 1500
M18x1.5	2x4	18	20	7	WNAM-M18/(2*4)	102 100 024 1500
M20x1.5	6x3	20	22	8	WNAM-M20/(6*3)	102 109 015 1002
M20x1.5	2x5	20	22	8	WNAM-M20/(2*5)	102 109 015 1001
M25x1.5	2x7	25	30	7.5	WNAM-M25/(2*7)	102 109 018 1001
M25x1.5	4x6	25	30	7.5	WNAM-M25/(4*6)	102 109 018 1004
M25x1.5	3x7	25	30	7.5	WNAM-M25/(3*7) <sup>2)</sup>	102 109 018 1003
M25x1.5	2x8	25	30	7.5	WNAM-M25/(2*8)	102 109 018 1002
M32x1.5	4x9	32	40	8	WNAM-M32/(4*9)	102 109 019 1002
M40x1.5	5x9	40	50	12	WNAM-M40/(5*9)	102 109 020 1002
M40x1.5	2x15	40	50	12	WNAM-M40/(2*15)	102 109 020 1001

1).MOQ 100 pcs. 2).MOQ 200 pcs. 3).MOQ 50 pcs. 4).MOQ 20 pcs.

## Cable glands

## Metal cable gland with multi-core - extra length

Material: Nickel-plate brass

Sealing: Nylon and NBR

Degree of protection: IP65(with O-sealing)

Temperature range: -40°C ...+100°C ,short-term 120°C

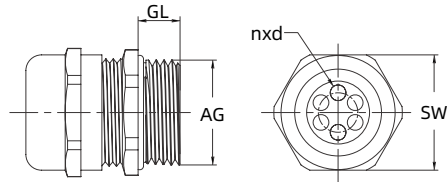

Unit: mm

Thread side	Clamping range(nxd)	Thread diameter(AG)	Wrench size(SW)	Thread length(GL)	Designation	Order NO.
Metric Thread						
M25x1.5	4x6	25	30	12	WNAM-M25L/(4*6) <sup>2)</sup>	102 109 018 1101
M32x1.5	4x9	32	40	12	WNAM-M32L/(4*9) <sup>2)</sup>	102 109 019 1102
M40x1.5	5x9	40	50	15	WNAM-M40L/(5*9) <sup>2)</sup>	102 109 020 1102
M40x1.5	2x15	40	50	15	WNAM-M40L/(2*15) <sup>2)</sup>	102 109 020 1101

1).MOQ 100 pcs. 2).MOQ 200 pcs. 3).MOQ 50 pcs. 4).MOQ 20 pcs.

## Cable glands

## Outer thread tube connector

Material: Zinc alloy,Zinc plated

Specialty: one end is connected to the flexible tube, the other end with thread to the switch chest or the device. The structure is compact and the surface has anti-corrosion function.

Applications: Electromotor, Cable bridge frame, Electric engineering, Electric control etc.

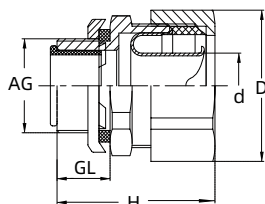

Unit: mm

Thread side	Fits to tubing size(d)	Thread length(GL)	External diameter(D)	Height(H)	Designation	Order NO.
PG Thread						
PG9	10	8.5	26	30	WNC-PG9/D10 <sup>4)</sup>	102 114 002 5001
PG11	12	10.5	27.5	32	WNC-PG11/D12	102 114 003 5001
PG13.5	15	11.5	31.5	34	WNC-PG13.5/D15	102 114 004 5001
PG16	15	12.5	32	34	WNC-PG16/D15	102 114 005 5001
PG21	20	13.5	38	37	WNC-PG21/D20	102 114 006 5001
PG29	25	15	45.5	44	WNC-PG29/D25	102 114 007 5001
PG29	32	14	55	52	WNC-PG29/D32	102 114 007 5003
PG36	38	17	62	51	WNC-PG36/D38	102 114 008 5001
PG42	38	17	62	51	WNC-PG42/D38	102 114 009 5001
PG48	51	19	77.5	56	WNC-PG48/D51	102 114 010 5001
Metric Thread						
M16x1.5	8	8	24	28	WNC-M16/D8 <sup>4)</sup>	102 114 013 5001
M16x1.5	10	8	25.5	30	WNC-M16/D10 <sup>4)</sup>	102 114 013 5003
M20x1.5	12	10	27.5	32	WNC-M20/D12	102 114 015 5001
M24x1.5	15	11.5	32	34	WNC-M24/D15 <sup>4)</sup>	102 114 017 5001
M25x1.5	20	12	37.5	37	WNC-M25/D20	102 114 018 5001
M30x2.0	20	13	38	37	WNC-M30/D20 <sup>4)</sup>	102 114 038 5001
M32x1.5	20	12.5	37.5	37	WNC-M32/D20	102 114 019 5005
M32x1.5	25	15	46	41	WNC-M32/D25	102 114 019 5001
M36x2.0	25	13	45	44	WNC-M36/D25 <sup>4)</sup>	102 114 040 5001
M40x1.5	32	15	55	47	WNC-M40/D32	102 114 020 5001

1).MOQ 100 pcs.    2).MOQ 200 pcs.    3).MOQ 50 pcs.    4).MOQ 20 pcs.

## Cable glands

## Quick tube connector

Material: Nylon 6

Temperature range: -40°C ...+120°C

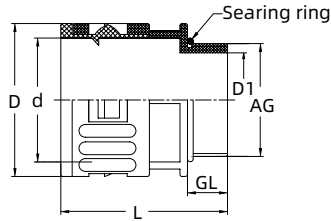

Unit: mm

Thread side	Fits to tubing size(d)	Thread length(GL)	Bore(D1)	External diameter(D)	Total length(L)	Designation(Black)	Order NO.
PG Thread							
PG7	AD10.0	9.5	7.5	17.0	34.5	WNCP-PG7B/AD10.0 <sup>2)</sup>	102 115 001 2002
PG9	AD13.0	9.5	11.5	20.0	34.5	WNCP-PG9B/AD13.0 <sup>2)</sup>	102 115 002 2002
PG11	AD15.8	9.5	14.0	23.0	36.0	WNCP-PG11B/AD15.8	102 115 003 2002
PG13.5	AD18.5	11.0	16.0	26.0	39.0	WNCP-PG13.5B/AD18.5	102 115 004 2002
PG16	AD21.2	13.0	18.0	29.5	44.0	WNCP-PG16B/AD21.2	102 115 005 2002
PG21	AD28.5	13.0	23.5	37.0	47.0	WNCP-PG21B/AD28.5	102 115 006 2002
PG29	AD34.5	11.5	30.5	43.5	47.0	WNCP-PG29B/AD34.5	102 115 007 2002
PG36	AD42.5	13.5	40.0	51.0	52.0	WNCP-PG36B/AD42.5	102 115 008 2002
Metric Thread							
M12x1.5	AD10.0	10.0	8.0	17.0	34.5	WNCP-M12B/AD10.0 <sup>2)</sup>	102 115 011 2002
M16x1.5	AD13.0	9.5	11.5	20.0	34.5	WNCP-M16B/AD13.0 <sup>2)</sup>	102 115 013 2002
M18x1.5	AD15.8	9.5	14.0	23.0	36.0	WNCP-M18B/AD15.8 <sup>2)</sup>	102 115 014 2002
M20x1.5	AD18.5	11.0	16.0	26.0	39.0	WNCP-M20B/AD18.5	102 115 015 2002
M20x1.5	AD21.2	13.0	15.0	29.5	44.0	WNCP-M20B/AD21.2	102 115 015 2004
M25x1.5	AD21.2	13.0	18.0	29.5	44.5	WNCP-M25B/AD21.2	102 115 018 2002
M25x1.5	AD28.5	13.0	20.5	37.0	47.0	WNCP-M25B/AD28.5	102 115 018 2004
M32x1.5	AD28.5	13.0	24.0	37.0	47.0	WNCP-M32B/AD28.5	102 115 019 2002
M40x1.5	AD34.5	11.0	30.0	43.5	48.0	WNCP-M40B/AD34.5	102 115 020 2002
M40x1.5	AD42.5	13.5	33.5	51.0	52.0	WNCP-M40B/AD42.5	102 115 020 2004
M50x1.5	AD54.5	13.5	42.5	63.5	53.5	WNCP-M50B/AD54.5	102 115 046 2004
M63x1.5	AD54.5	14.0	55.0	63.5	53.5	WNCP-M63B/AD54.5	102 115 048 2002

1).MOQ 100 pcs. 2).MOQ 200 pcs. 3).MOQ 50 pcs. 4).MOQ 20 pcs.



## Cable glands

## Nylon plug

Material: Nylon 6

Temperature range: -40°C ...+120°C

Degree of protection: IP68(with O-sealing)

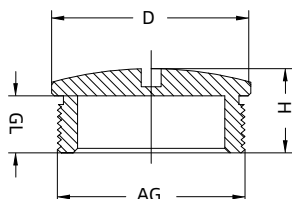

Unit: mm

Thread side	Thread length(GL)	Height(H)	Thread diameter(AG)	External diameter(D)	Designation	Order NO.
PG Thread						
PG7	6.0	10.0	12.5	15.5	WNPP-PG7G/R <sup>1)</sup>	102 102 001 2101
PG9	6.0	10.0	15.2	18.5	WNPP-PG9G/R <sup>1)</sup>	102 102 002 2101
PG11	8.0	11.5	18.6	22.0	WNPP-PG11G/R <sup>1)</sup>	102 102 003 2101
PG13.5	8.0	11.5	20.4	24.0	WNPP-PG13.5G/R	102 102 004 2101
PG16	8.0	12.0	22.5	27.0	WNPP-PG16G/R	102 102 005 2101
PG21	7.5	12.0	28.3	33.0	WNPP-PG21G/R	102 102 006 2101
PG29	8.0	12.0	37.0	43.0	WNPP-PG29G/R	102 102 007 2101
PG36	10.5	14.0	47.0	55.0	WNPP-PG36G/R	102 102 008 2101
PG42	11.0	15.5	54.0	62.0	WNPP-PG42G/R	102 102 009 2101
PG48	13.0	17.0	59.3	68.5	WNPP-PG48G/R	102 102 010 2101
Metric Thread						
M12x1.5	6.0	10.0	12.0	15.0	WNPP-M12G/R <sup>1)</sup>	102 102 011 2101
M16x1.5	5.5	10.0	16.0	18.5	WNPP-M16G/R <sup>1)</sup>	102 102 013 2101
M20x1.5	8.0	11.5	20.0	25.0	WNPP-M20G/R	102 102 015 2101
M25x1.5	7.5	12.5	25.0	29.5	WNPP-M25G/R	102 102 018 2101
M32x1.5	9.0	13.5	32.0	39.0	WNPP-M32G/R	102 102 019 2101
M40x1.5	11.0	15.0	40.0	48.0	WNPP-M40G/R	102 102 020 2101
M50x1.5	12.0	18.0	50.0	61.5	WNPP-M50G/R	102 102 046 2101
M63x1.5	12.5	18.0	63.0	70.5	WNPP-M63G/R	102 102 048 2101

1).MOQ 100 pcs. 2).MOQ 200 pcs. 3).MOQ 50 pcs. 4).MOQ 20 pcs.

## Cable glands

## Metal plug

Material: Nickel-plate brass

Temperature range: -40°C ...+120°C

Degree of protection: IP68(with O-sealing)

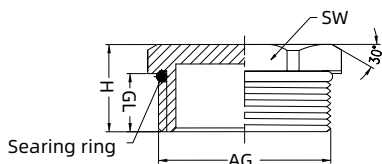

Unit: mm

Thread side	Thread length(GL)	Height(H)	Thread diameter(AG)	Wrench size(SW)	Designation	Order NO.
PG Thread						
PG7	5	8	12.5	14	WNP-PG7 <sup>1)</sup>	102 101 001 1001
PG9	6	9	15.2	18	WNP-PG9 <sup>1)</sup>	102 101 002 1001
PG11	6	10	18.6	20	WNP-PG11	102 101 003 1001
PG13.5	7	10	20.4	22	WNP-PG13.5	102 101 004 1001
PG16	7	10	22.5	24	WNP-PG16	102 101 005 1001
PG21	7	11	28.3	30	WNP-PG21	102 101 006 1001
PG29	8	13	37.0	40	WNP-PG29	102 101 007 1001
PG36	8	13	47.0	50	WNP-PG36	102 101 008 1001
PG42	9	15	54.0	55	WNP-PG42	102 101 009 1001
PG48	10	17	59.3	65	WNP-PG48	102 101 010 1001
Metric Thread						
M12x1.5	5	8	12	14	WNP-M12 <sup>1)</sup>	102 101 011 1001
M16x1.5	6	9	16	18	WNP-M16 <sup>1)</sup>	102 101 013 1001
M18x1.5	6	10	18	20	WNP-M18 <sup>1)</sup>	102 101 014 1001
M20x1.5	6	9.5	20	22	WNP-M20	102 101 015 1001
M22x1.5	7	10	22	24	WNP-M22 <sup>1)</sup>	102 101 016 1001
M24x1.5	7	11	24	27	WNP-M24 <sup>1)</sup>	102 101 017 1001
M25x1.5	7	11	25	27	WNP-M25	102 101 018 1001
M32x1.5	7	11	32	35	WNP-M32	102 101 019 1001
M36x1.5	8	12	36	40	WNP-M36	102 101 040 1001
M40x1.5	8	13	40	45	WNP-M40	102 101 020 1001
M48x1.5	9	15	48	50	WNP-M48 <sup>3)</sup>	102 101 045 1001
M50x1.5	9	13	50	55	WNP-M50	102 101 046 1001
M63x1.5	10	17	63	70	WNP-M63	102 101 048 1001

1).MOQ 100 pcs. 2).MOQ 200 pcs. 3).MOQ 50 pcs. 4).MOQ 20 pcs.

## Cable glands

## Metal enlargement

Material : Nickel-plate brass

Shape: Round, Hexagonal

Applications: Apply to the situation of the diameter need to be enlarged

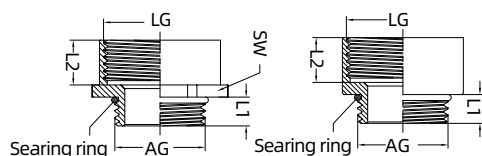

Hexagonal metal enlargement    Round metal enlargement

Unit: mm

Outside thread(AG)	Inside thread(LG)	Outside thread length(L1)	Inside thread length(L2)	Wrench size(SW)	cDesignation (Hexagonal)	Order NO.	Designation(Round)	Order NO.
PG Thread		Round/ Hexagonal	Round/ Hexagonal	Hexagonal				
PG7	PG9	5.0/5.0	8.0/10.0	17	WNSC-PG7PG9 <sup>2)</sup>	102 103 001 1002	WNSC-PG7PG9R <sup>2)</sup>	102 103 001 1102
PG9	PG11	6.0/6.0	10.0/12.0	20	WNSC-PG9PG11 <sup>2)</sup>	102 103 002 1002	WNSC-PG9PG11R <sup>2)</sup>	102 103 002 1102
PG11	PG13.5	6.0/6.0	10.0/12.0	22	WNSC-PG11PG13.5 <sup>2)</sup>	102 103 003 1002	WNSC-PG11PG13.5R <sup>2)</sup>	102 103 003 1102
PG13.5	PG16	6.5/6.5	11.0/13.0	24	WNSC-PG13.5PG16	102 103 004 1002	WNSC-PG13.5PG16R	102 103 004 1102
PG16	PG21	6.5/6.5	12.0/14.0	30	WNSC-PG16PG21	102 103 005 1002	WNSC-PG16PG21R	102 103 005 1102
PG21	PG29	8.0/7.0	13.5/15.0	40	WNSC-PG21PG29	102 103 006 1002	WNSC-PG21PG29R	102 103 006 1102
PG29	PG36	8.0/8.0	15.5/17.0	50	WNSC-PG29PG36	102 103 007 1002	WNSC-PG29PG36R	102 103 007 1102
PG36	PG42	9.0/9.0	14.5/16.0	57	WNSC-PG36PG42	102 103 008 1002	WNSC-PG36PG42R	102 103 008 1102
PG42	PG48	10.0/10.0	14.5/16.0	65	WNSC-PG42PG48	102 103 009 1002	WNSC-PG42PG48R	102 103 009 1102
Metric Thread								
M12x1.5	M16x1.5	5.0/5.0	8.0/10.0	18	WNSC-M12M16 <sup>2)</sup>	102 103 011 1002	WNSC-M12M16R <sup>2)</sup>	102 103 011 1102
M16x1.5	M20x1.5	6.0/6.0	10.0/12.0	22	WNSC-M16M20 <sup>2)</sup>	102 103 013 1002	WNSC-M16M20R <sup>2)</sup>	102 103 013 1102
M20x1.5	M25x1.5	8.0/6.5	13.5/11.0	27	WNSC-M20M25	102 103 015 1002	WNSC-M20M25R	102 103 015 1102
M25x1.5	M32x1.5	7.5/6.5	13.5/12.0	35	WNSC-M25M32	102 103 018 1002	WNSC-M25M32R	102 103 018 1102
M32x1.5	M40x1.5	10.0/7.0	13.5/15.0	45	WNSC-M32M40	102 103 019 1002	WNSC-M32M40R	102 103 019 1102
M40x1.5	M50x1.5	10.0/9.0	14.5/18.0	55	WNSC-M40M50	102 103 020 1002	WNSC-M40M50R	102 103 020 1102
M50x1.5	M63x1.5	9.0/9.0	14.5/16.0	65	WNSC-M50M63 <sup>2)</sup>	102 103 046 1002	WNSC-M50M63R <sup>2)</sup>	102 103 046 1102

1).MOQ 100 pcs.    2).MOQ 200 pcs.    3).MOQ 50 pcs.    4).MOQ 20 pcs.

## Cable glands

## Polyamide enlargement

Material: Polyamide

Color: Grey

Temperature range: -40°C ...+100°C

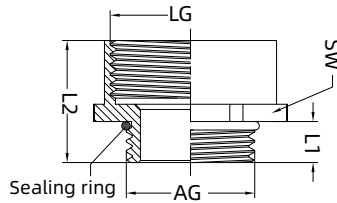

Unit: mm

Outside thread(AG)	Inside thread(LG)	Thread length(L1)	Total length(L2)	Wrench size(SW)	Designation	Order NO.
<b>PG Thread</b>						
PG7	PG9	8	20	19	WNSCP-PG7PG9 <sup>2)</sup>	102 103 001 2002
PG9	PG11	10	24	22	WNSCP-PG9PG11 <sup>2)</sup>	102 103 002 2002
PG11	PG13.5	8	23	24	WNSCP-PG11PG13.5 <sup>2)</sup>	102 103 003 2002
PG13.5	PG16	8	25	27	WNSCP-PG13.5PG16	102 103 004 2002
PG16	PG21	10	27	30	WNSCP-PG16PG21	102 103 005 2002
PG21	PG29	11	32	42	WNSCP-PG21PG29	102 103 006 2002
PG29	PG36	11	35	52	WNSCP-PG29PG36	102 103 007 2002
PG36	PG42	13	42	60	WNSCP-PG36PG42	102 103 008 2002
PG42	PG48	15	65	65	WNSCP-PG42PG48	102 103 009 2002
<b>Metric Thread</b>						
M12x1.5	M16x1.5	8	22	20	WNSCP-M12M16 <sup>2)</sup>	102 103 011 2002
M16x1.5	M20x1.5	10	27	27	WNSCP-M16M20 <sup>2)</sup>	102 103 013 2002
M20x1.5	M25x1.5	8	25	30	WNSCP-M20M25	102 103 015 2002
M25x1.5	M32x1.5	11	30	36	WNSCP-M25M32	102 103 018 2002
M32x1.5	M40x1.5	15	34	45	WNSCP-M32M40	102 103 019 2002
M40x1.5	M50x1.5	13	37	55	WNSCP-M40M50	102 103 020 2002

1).MOQ 100 pcs. 2).MOQ 200 pcs. 3).MOQ 50 pcs. 4).MOQ 20 pcs.

## Cable glands

## Metal reducer

Material: Nickel-plate brass

Shape: Round, Hexagonal

Applications: Apply to the situation of the diameter need to be reduced

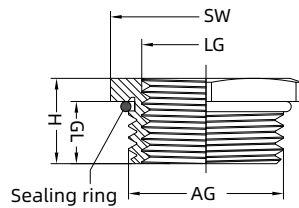

Unit: mm

Outside thread(AG)	Inside thread(LG)	Thread length(GL)	Total length(H)	Wrench size(SW)	Designation (Hexagonal)	Order NO.
PG Thread						
PG9	PG7	6.0	9	17	WNSC-PG9PG7 <sup>2)</sup>	102 104 002 1001
PG11	PG9	7.0	11	20	WNSC-PG11PG9 <sup>2)</sup>	102 104 003 1001
PG13.5	PG11	7.0	10	22	WNSC-PG13.5PG11 <sup>2)</sup>	102 104 004 1001
PG16	PG13.5	7.0	11	24	WNSC-PG16PG13.5	102 104 005 1001
PG21	PG16	7.0	11	30	WNSC-PG21PG16	102 104 006 1001
PG29	PG21	8.0	13	40	WNSC-PG29PG21	102 104 007 1001
PG36	PG29	9.0	13	50	WNSC-PG36PG29	102 104 008 1001
PG42	PG36	9.0	15	57	WNSC-PG42PG36 <sup>2)</sup>	102 104 009 1001
PG48	PG42	10.0	15	65	WNSC-PG48PG42 <sup>2)</sup>	102 104 010 1001
Metric Thread						
M16x1.5	M12x1.5	6.0	9	17	WNSC-M16M12 <sup>2)</sup>	102 104 013 1001
M20x1.5	M16x1.5	7.0	10	22	WNSC-M20M16 <sup>2)</sup>	102 104 015 1001
M25x1.5	M20x1.5	7.0	10	27	WNSC-M25M20	102 104 018 1001
M32x1.5	M25x1.5	8.0	11.5	35	WNSC-M32M25	102 104 019 1001
M40x1.5	M32x1.5	9.0	13	42	WNSC-M40M32	102 104 020 1001
M50x1.5	M40x1.5	9.0	14	57	WNSC-M50M40 <sup>2)</sup>	102 104 046 1001
M63x1.5	M50x1.5	11.0	14	65	WNSC-M63M50 <sup>2)</sup>	102 104 048 1001

1).MOQ 100 pcs. 2).MOQ 200 pcs. 3).MOQ 50 pcs. 4).MOQ 20 pcs.

## Cable glands

## Polyamide reducer

Material : Polyamide

Color: Grey

Temperature range: -40°C ...+100°C

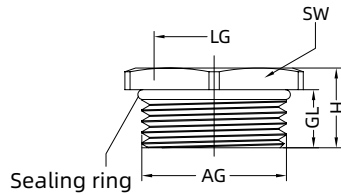

Shape A

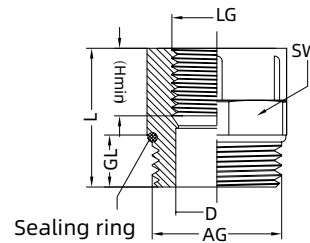

Shape B

Unit: mm

Outside thread(AG)	Inside thread(LG)	Thread length(GL)	Total length(H)	Wrench size(SW)	Shape	Designation	Order NO.
PG Thread							
PG11	PG9	9	15	24	A	WNSCP-PG11PG9 <sup>2)</sup>	102 104 003 2001
PG13.5	PG11	7.5	12	22	B	WNSCP-PG13.5PG11/H <sup>2)</sup>	102 127 004 2001
PG16	PG11	10	13	27	B	WNSCP-PG16PG11/H <sup>2)</sup>	102 127 005 2002
PG16	PG13.5	10.5	15	27	B	WNSCP-PG16PG13.5/H <sup>2)</sup>	102 127 005 2001
PG21	PG16	11	17	39	A	WNSCP-PG21PG16	102 104 006 2001
PG29	PG21	11.5	17	39	A	WNSCP-PG29PG21	102 104 007 2001
Metric Thread							
M20x1.5	M16x1.5	9.5	15	24	A	WNSCP-M20M16 <sup>2)</sup>	102 104 015 2001
M25x1.5	M20x1.5	10	17	27	A	WNSCP-M25M20	102 104 018 2001
M32x1.5	M20x1.5	11.5	17	39	A	WNSCP-M32M20	102 104 019 2002
M32x1.5	M25x1.5	11	17	39	A	WNSCP-M32M25	102 104 019 2001

1).MOQ 100 pcs. 2).MOQ 200 pcs. 3).MOQ 50 pcs. 4).MOQ 20 pcs.

## Cable glands

## Metal lock nut

Material: Nickel-plate brass

Temperature range: -40°C ...+100°C

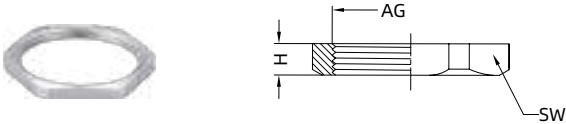

				Unit: mm
Thread side(AG)	Wrench size(SW)	Thickness(H)	Designation	Order NO.
PG Thread				
PG7	15	2.8	WNA-PG7/S <sup>1)</sup>	102 105 001 1101
PG9	18	2.8	WNA-PG9/S <sup>1)</sup>	102 105 002 1101
PG11	21	3.0	WNA-PG11/S	102 105 003 1101
PG13.5	22	3.0	WNA-PG13.5/S	102 105 004 1101
PG16	24	3.0	WNA-PG16/S	102 105 005 1101
PG21	30	3.5	WNA-PG21/S	102 105 006 1101
PG29	40	4.0	WNA-PG29/S	102 105 007 1101
PG36	50	4.5	WNA-PG36/S	102 105 008 1101
PG42	57	5.0	WNA-PG42/S	102 105 009 1101
PG48	65	5.5	WNA-PG48/S <sup>3)</sup>	102 105 010 1101
Metric Thread				
M12x1.5	15	2.8	WNA-M12/S <sup>1)</sup>	102 105 011 1101
M16x1.5	18	2.8	WNA-M16/S <sup>1)</sup>	102 105 013 1101
M20x1.5	22	3.0	WNA-M20/S	102 105 015 1101
M25x1.5	27	3.0	WNA-M25/S	102 105 018 1101
M32x1.5	35	3.5	WNA-M32/S	102 105 019 1101
M40x1.5	50	4.5	WNA-M40/S	102 105 020 1101
M50x1.5	57	5.0	WNA-M50/S <sup>1)</sup>	102 105 046 1101
M63x1.5	70	5.5	WNA-M63/S <sup>1)</sup>	102 105 048 1101

1).MOQ 100 pcs. 2).MOQ 200 pcs. 3).MOQ 50 pcs. 4).MOQ 20 pcs.

## Cable glands

## Polyamide lock nut

Material: Polyamide

Color: Grey,Black

Temperature range: -40°C ...+100°C

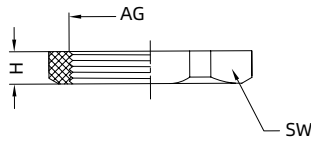

Unit: mm

Thread side(AG)	Wrench size(SW)	Thickness(H)	Designation( 灰色 )	Order NO.	Designation(Black)	Order NO.
PG Thread						
PG7	19	5.0	WNAP-PG7G/S <sup>1)</sup>	102 106 001 2101	WNAP-PG7B/S <sup>1)</sup>	102 106 001 2102
PG9	22	5.0	WNAP-PG9G/S <sup>1)</sup>	102 106 002 2101	WNAP-PG9B/S <sup>1)</sup>	102 106 002 2102
PG11	24	5.0	WNAP-PG11G/S	102 106 003 2101	WNAP-PG11B/S	102 106 003 2102
PG13.5	27	6.0	WNAP-PG13.5G/S	102 106 004 2101	WNAP-PG13.5B/S	102 106 004 2102
PG16	30	6.0	WNAP-PG16G/S	102 106 005 2101	WNAP-PG16B/S	102 106 005 2102
PG21	36	7.0	WNAP-PG21G/S	102 106 006 2101	WNAP-PG21B/S	102 106 006 2102
PG29	45	7.0	WNAP-PG29G/S	102 106 007 2101	WNAP-PG29B/S	102 106 007 2102
PG36	59	8.0	WNAP-PG36G/S	102 106 008 2101	WNAP-PG36B/S	102 106 008 2102
PG42	65	8.0	WNAP-PG42G/S <sup>1)</sup>	102 106 009 2101	WNAP-PG42B/S <sup>1)</sup>	102 106 009 2102
PG48	70	8.0	WNAP-PG48G/S <sup>1)</sup>	102 106 010 2101	WNAP-PG48B/S <sup>1)</sup>	102 106 010 2102
Metric Thread						
M12x1.5	19	5.0	WNAP-M12G/S <sup>1)</sup>	102 106 011 2101	WNAP-M12B/S <sup>1)</sup>	102 106 011 2102
M16x1.5	22	5.0	WNAP-M16G/S <sup>1)</sup>	102 106 013 2101	WNAP-M16B/S <sup>1)</sup>	102 106 013 2102
M18x1.5	24	5.0	WNAP-M18G/S <sup>1)</sup>	102 106 014 2101	WNAP-M18B/S <sup>1)</sup>	102 106 014 2102
M20x1.5	27	6.0	WNAP-M20G/S	102 106 015 2101	WNAP-M20B/S	102 106 015 2102
M22x1.5	30	6.0	WNAP-M22G/S <sup>1)</sup>	102 106 016 2101	WNAP-M22B/S <sup>1)</sup>	102 106 016 2102
M24x1.5	30	6.0	WNAP-M24G/S <sup>1)</sup>	102 106 017 2101	WNAP-M24B/S <sup>1)</sup>	102 106 017 2102
M25x1.5	32	7.0	WNAP-M25G/S	102 106 018 2101	WNAP-M25B/S	102 106 018 2102
M32x1.5	40	7.0	WNAP-M32G/S	102 106 019 2101	WNAP-M32B/S	102 106 019 2102
M40x1.5	49	8.0	WNAP-M40G/S	102 106 020 2101	WNAP-M40B/S	102 106 020 2102
M50x1.5	65	8.0	WNAP-M50G/S <sup>1)</sup>	102 106 046 2101	WNAP-M50B/S <sup>1)</sup>	102 106 046 2102
M63x1.5	74	8.0	WNAP-M63G/S <sup>1)</sup>	102 106 048 2101	WNAP-M63B/S <sup>1)</sup>	102 106 048 2102

1).MOQ 100 pcs. 2).MOQ 200 pcs. 3).MOQ 50 pcs. 4).MOQ 20 pcs.





Metal lock nut

Material: Nickel-plate brass  
 Temperature range: -40°C ...+100°C

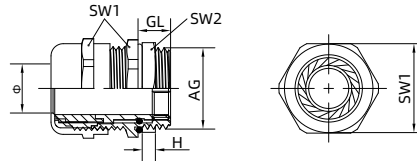

Unit: mm

Thread side	Clamping range(Φ)	Thread diameter(AG)	Wrench size(SW1)	Thread length(GL)	Designation	Order NO.	Dimension of nut wrench(SW2)	Nut thickness H
PG Thread								
PG7	3-6.5	12.5	15	7	WNAS-PG7/S(D3-6.5)	102 129 001 3500	15	3
PG9	4-8	15.2	18	8	WNAS-PG9/S(D4-8)	102 129 002 3500	18	3.5
PG11	5-10	18.6	21	8.5	WNAS-PG11/S(D5-10)	102 129 003 3500	21	3.5
PG13.5	6-12	20.4	23	9	WNAS-PG13.5/S(D6-12)	102 129 004 3500	23	3.5
PG16	10-14	22.5	24	8.5	WNAS-PG16/S(D10-14)	102 129 005 3500	24	3.5
PG21	14-18	28.3	30	8	WNAS-PG21/S(D14-18)	102 129 006 3001	30	3.5
PG29	18-25	37	40	10	WNAS-PG29/S(D18-25)	102 129 007 3500	40	4
PG36	22-32	47	50	13	WNAS-PG36/S(D22-32)	102 129 008 3001	50	5
PG42	32-38	54	57	13	WNAS-PG42/S(D32-38)	102 129 009 3500	57	5
PG48	29-35	59.3	65	13	WNAS-PG48/S(D29-35)	102 129 010 3500	65	6
PG48	37-44	59.3	65	13	WNAS-PG48/S(D37-44)	102 129 010 3501	65	6
Metric Thread								
M12x1.5	3-6.5	12	15	7	WNAS-M12/S(D3-6.5)	102 129 021 3501	15	3
M12x1.5	3-6.5	16	18	8	WNAS-M12/S(D3-6.5)	102 129 023 3501	18	3.5
M16x1.5	5-10	16	21	8.5	WNAS-M16/S(D5-10)	102 129 023 3502	21	3.5
M18x1.5	5-10	18	21	8.5	WNAS-M18/S(D5-10)	102 129 024 3500	21	3.5
M20x1.5	5-9	20	22	9	WNAS-M20/S(D5-9)	102 129 025 3503	23	3.5
M20x1.5	6-12	20	23	9	WNAS-M20/S(D6-12)	102 129 025 3502	23	3.5
M25x1.5	10-14	20	24	8.5	WNAS-M20/S(D10-14)	102 129 025 3501	23	3.5
M25x1.5	12-16	25	27	10	WNAS-M25/S(D12-16)	102 129 028 3500	27	3.5
M40x1.5	13-18	25	30	8	WNAS-M25/S(D13-18)	102 129 018 3001	30	3.5
M40x1.5	18-25	40	45	12	WNAS-M40/S(D18-25)	102 129 030 3500	45	5
M40x1.5	22-32	40	50	13	WNAS-M40/S(D22-32)	102 129 030 3501	50	5
M50x1.5	25-31	50	57	13	WNAS-M50/S(D25-31)	102 129 032 3500	57	5
M50x1.5	29-35	50	57	13	WNAS-M50/S(D29-35)	102 129 032 3502	57	5
M50x1.5	32-38	50	57	13	WNAS-M50/S(D32-38)	102 129 032 3501	57	5

1).MOQ 100 pcs.    2).MOQ 200 pcs.    3).MOQ 50 pcs.    4).MOQ 20 pcs.

## Stainless steel cable joint



## Metal lock nut

Material: Nickel-plate brass

Temperature range: -40°C ...+100°C

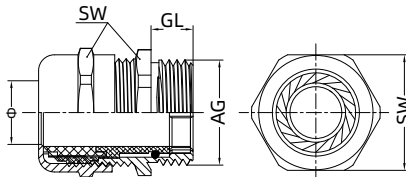

Unit: mm

Thread side	Clamping range( $\Phi$ )	Thread diameter(AG)	Wrench size(SW)	Thread length(GL)	Designation	Order NO.
PG Thread						
PG7	3-6.5	12.5	15	7	WNAS-PG7(D3-6.5)	102 129 001 3501
PG9	4-8	15.2	18	8	WNAS-PG9(D4-8)	102 129 002 3501
PG11	5-10	18.6	21	8.5	WNAS-PG11(D5-10)	102 129 003 3501
PG13.5	6-12	20.4	23	9	WNAS-PG13.5(D6-12)	102 129 004 3501
PG16	10-14	22.5	24	8.5	WNAS-PG16(D10-14)	102 129 005 3501
PG21	14-18	28.3	30	8	WNAS-PG21(D14-18)	102 129 006 3500
PG29	18-25	37	40	10	WNAS-PG29(D18-25)	102 129 007 3501
PG36	22-32	47	50	13	WNAS-PG36(D22-32)	102 129 008 3500
PG42	32-38	54	57	13	WNAS-PG42(D32-38)	102 129 009 3501
PG48	29-35	59.3	65	13	WNAS-PG48(D29-35)	102 129 010 3502
PG48	37-44	59.3	65	13	WNAS-PG48(D37-44)	102 129 010 3503
Metric Thread						
M12x1.5	3-6.5	12	15	7	WNAS-M12(D3-6.5)	102 129 021 3500
M12x1.5	3-6.5	16	18	8	WNAS-M16(D4-8)	102 129 023 3500
M16x1.5	5-10	16	21	8.5	WNAS-M16(D5-10)	102 129 023 3503
M18x1.5	5-10	18	21	8.5	WNAS-M18(D5-10)	102 129 024 3501
M20x1.5	5-9	20	22	9	WNAS-M20(D5-9)	102 129 025 3504
M20x1.5	6-12	20	23	9	WNAS-M20(D6-12)	102 129 025 3505
M25x1.5	10-14	20	24	8.5	WNAS-M20(D10-14)	102 129 025 3500
M25x1.5	12-16	25	27	10	WNAS-M25(D12-16)	102 129 028 3501
M40x1.5	13-18	25	30	8	WNAS-M25(D13-18)	102 129 029 3501
M40x1.5	18-25	40	45	12	WNAS-M40(D18-25)	102 129 030 3502
M40x1.5	22-32	40	50	13	WNAS-M40(D22-32)	102 129 030 3503
M50x1.5	25-31	50	57	13	WNAS-M50(D25-31)	102 129 032 3503
M50x1.5	29-35	50	57	13	WNAS-M50(D29-35)	102 129 032 3504
M50x1.5	32-38	50	57	13	WNAS-M50(D32-38)	102 129 032 3505

1).MOQ 100 pcs. 2).MOQ 200 pcs. 3).MOQ 50 pcs. 4).MOQ 20 pcs.





**XIAMEN WAIN ELECTRICAL CO.,LTD**

Add: No. 600, Shanting Road, Min'an Street,  
Xiang'an District, Xiamen

Tel: +86-592-7227565

+86-592-7227516

Fax: +86-592-7227569

Email: [info@wainconnector.com](mailto:info@wainconnector.com)

[wainconnector@wainconnector.com](mailto:wainconnector@wainconnector.com)

Website: [www.wainconnector.com](http://www.wainconnector.com)

Free Call(in China): [400-882-5885](tel:400-882-5885)



WAIN WeChat



WAIN Website



WAIN E-Shop